

Low Voltage 3-Mode 2ch 150mA LDO

NO.EA-139-061106

OUTLINE

The R5328K Series are dual 150mA voltage regulator ICs with 3-mode. The 3-mode describes that they are the inactive standby, the active fast mode, and the active low power mode. The two active modes can be switched over with ECO pin. With this function, the output voltage maintains the level, and the mode can be switched over.

The minimum operating voltage is 1.4V, and the output voltage range is from 0.8V to 4.0V.

Since the package for these ICs is PLP2020-8, high density mounting of the ICs on boards is possible.

FEATURES

- Supply Current (Low Power Mode)..... Typ. $2.0\mu\text{A}\times 2$ (VR1&VR2) ($V_{\text{OUT}} < 2.0\text{V}$)
Typ. $2.5\mu\text{A}\times 2$ (VR1&VR2) ($V_{\text{OUT}} \geq 2.0\text{V}$)
 - Supply Current (Fast Mode)..... Typ. $75\mu\text{A}\times 2$ (VR1&VR2) ($V_{\text{OUT}} < 2.0\text{V}$)
Typ. $65\mu\text{A}\times 2$ (VR1&VR2) ($V_{\text{OUT}} \geq 2.0\text{V}$)
 - Standby Mode Typ. $0.1\mu\text{A}$ (VR1&VR2)
 - Input Voltage 1.4V to 6.0V
 - Output Voltage 0.8V to 4.0V
 - Dropout Voltage Typ. 0.25V ($I_{\text{OUT}}=150\text{mA}$ $V_{\text{OUT}}=2.8\text{V}$)
 - Ripple Rejection (Fast Mode) Typ. 70dB ($f=1\text{kHz}$, $V_{\text{OUT}}=2.8\text{V}$)
Typ. 55dB ($f=10\text{kHz}$, $V_{\text{OUT}}=2.8\text{V}$)
 - Excellent Line Regulation Typ. 0.02%/V ($V_{\text{OUT}} \geq 1.5\text{V}$)
 - Output Voltage Accuracy (Fast Mode) $\pm 1.0\%$
 - Output Voltage Accuracy (Low Power Mode) ... $\pm 1.5\%$
 - Low Temperature-drift Coefficient of Output Voltage Typ. $\pm 100\text{ppm}/^\circ\text{C}$
 - Package PLP2020-8
 - Built-in fold-back protection circuit Typ. 50mA (Current at short mode)
 - Ceramic Capacitor is recommended. 1.0 μF
 - Built-in chip enable circuit (A/B: active high)
- (Depending on V_{IN} and set V_{OUT} . Refer to the electrical characteristics table.)

APPLICATIONS

- Power source for handheld communication equipment.
- Power source for electrical appliances such as cameras, VCRs and camcorders.
- Power source for battery-powered equipment.

BLOCK DIAGRAMS

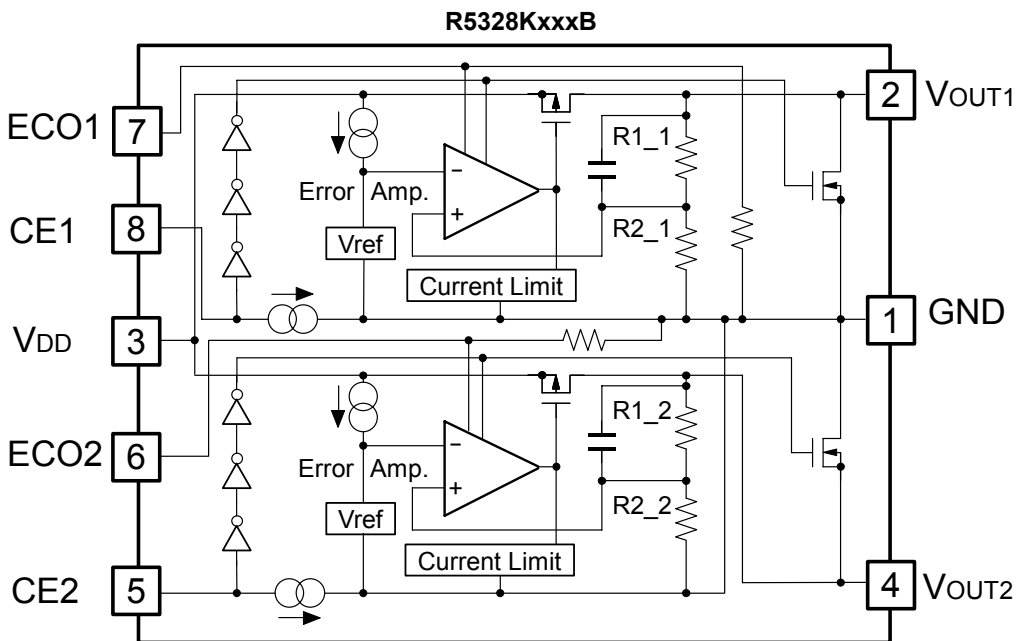
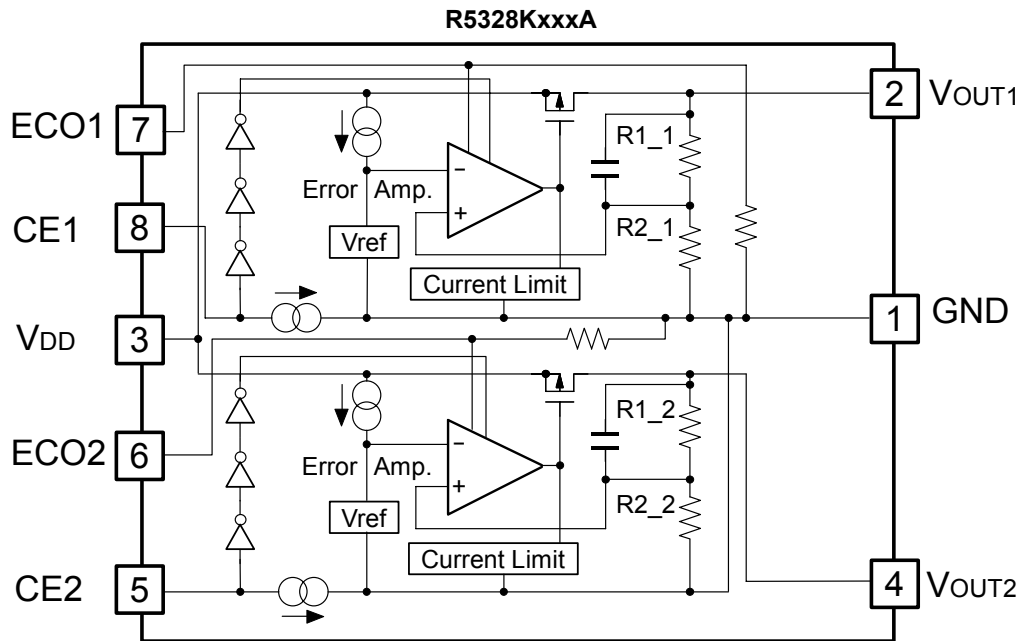

SELECTION GUIDE

The output voltage, mask option, and the taping type for the ICs can be selected at the user's request.
The selection can be made with designating the part number as shown below;

R5328Kxxxx-xx-x ← Part Number
 ↑ ↑ ↑ ↑ ↑
 a b c d e

Code	Contents
a	Designation of Package Type: K: PLP2020-8
b	Setting combination of 2ch Output Voltage (V_{OUT}): Serial Number for Voltage Setting, Stepwise setting with a step of 0.1V in the range of 0.8V to 4.0V is possible for each channel.
c	Designation of Mask Option: A: without auto discharge function at OFF state. B: with auto discharge function at OFF state.
d	Designation of Taping Type: Ex. TR (refer to Taping Specifications; TR type is the standard direction.)
e	Designation of composition of plating: None : Au plating

PIN CONFIGURATION

- PLP2020-8

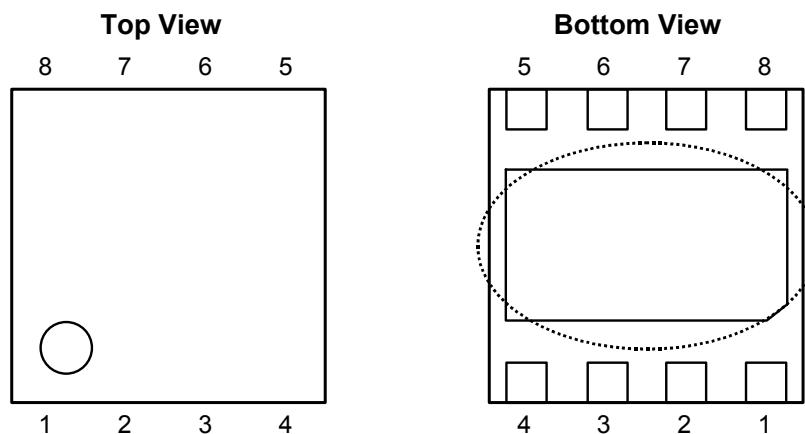

PIN DESCRIPTIONS

- R5328K

Pin No.	Symbol	Description
1	GND	Ground Pin
2	V_{OUT1}	Output Pin 1
3	V_{DD}	Input Pin
4	V_{OUT2}	Output Pin 2
5	CE2	Chip Enable Pin 2
6	ECO2	Low Power/ Fast Mode Changer Pin2
7	ECO1	Low Power/ Fast Mode Changer Pin1
8	CE1	Chip Enable Pin 1

* Tab in the  parts have GND level. (They are connected to the reverse side of this IC.)
Do not connect to other wires or land patterns.

ABSOLUTE MAXIMUM RATINGS

Symbol	Item	Rating	Unit
V_{IN}	Input Voltage	6.0	V
V_{CE1}, V_{CE2} V_{ECO1}, V_{ECO2}	Input Voltage (CE/ECO Pin)	-0.3 to 6.5	V
V_{OUT1}, V_{OUT2}	Output Voltage	-0.3 to $V_{IN}+0.3$	V
I_{OUT1}, I_{OUT2}	Output Current	160	mA
P_D	Power Dissipation (PLP2020-8)*1	880	mW
T_{opt}	Operating Temperature Range	-40 to +85	°C
T_{stg}	Storage Temperature Range	-55 to +125	°C

*1) For Power Dissipation, please refer to PACKAGE INFORMATION to be described.

ELECTRICAL CHARACTERISTICS

• R5328KxxxA/B

(T_{opt}=25°C)

Symbol	Item	Conditions	MIN.	TYP.	MAX.	Unit	
V _{OUT}	Output Voltage (Fast Mode)	V _{IN} =Set V _{OUT} +1V I _{OUT} =1mA V _{ECO} =V _{IN}	V _{OUT} >1.5	×0.99	×1.01	V	
			V _{OUT} ≤ 1.5	-15	+15	mV	
	Output Voltage (Low Power Mode)	V _{IN} =Set V _{OUT} +1V I _{OUT} =1mA V _{ECO} =GND	V _{OUT} >1.5	×0.985	×1.015	V	
			V _{OUT} ≤ 1.5	-22.5	+22.5	mV	
I _{OUT}	Output Current	V _{IN} -V _{OUT} =1.0V	150			mA	
ΔV _{OUT} / ΔI _{OUT}	Load Regulation (Fast Mode)	V _{IN} =Set V _{OUT} +1V, V _{ECO} =V _{IN} 1mA ≤ I _{OUT} ≤ 150mA		20	40	mV	
	Load Regulation (Low Power Mode)	V _{IN} =Set V _{OUT} +1V, V _{ECO} =GND 1mA ≤ I _{OUT} ≤ 150mA		25	45	mV	
V _{DIF}	Dropout Voltage	Refer to the ELECTRICAL CHARACTERISTICS by OUTPUT VOLTAGE					
I _{SS1}	Supply Current (Fast Mode)	V _{IN} =Set V _{OUT} +1V, I _{OUT} =0mA, V _{ECO} =V _{IN}	V _{OUT} <2.0		75	95	μA
			V _{OUT} ≥ 2.0		65	95	
I _{SS2}	Supply Current (Low Power Mode)	V _{IN} =Set V _{OUT} +1V, V _{ECO} =GND, Except CE pull-down current	V _{OUT} <2.0		2	4	μA
			V _{OUT} ≥ 2.0		2.5	4	
I _{standby}	Supply Current (Standby)	V _{IN} =Set V _{OUT} +1V, V _{CE} =GND		0.1	1	μA	
ΔV _{OUT} / ΔV _{IN}	Line Regulation (Fast Mode)	Set V _{OUT} + 0.5V ≤ V _{IN} ≤ 6V, I _{OUT} =1mA,	V _{ECO} =GND		0.02	0.1	%V
	Line Regulation (Low Power Mode)	If V _{OUT} ≤ 0.9: 0.5V ≤ V _{IN} ≤ 6V	V _{ECO} =V _{IN}		0.1	0.2	
RR	Ripple Rejection	Ripple 0.2Vp-p, V _{IN} =Set V _{OUT} +1V, I _{OUT} =30mA V _{ECO} =V _{IN}	f=1kHz		70		dB
			f=10kHz		55		
V _{IN}	Input Voltage		1.4		6.0	V	
ΔV _{OUT} / ΔT _{opt}	Output Voltage Temperature Coefficient	I _{OUT} =1mA, -40°C ≤ T _{opt} ≤ 85°C		±100		ppm/ °C	
I _{lim}	Short Current Limit	V _{OUT} =0V		50		mA	
I _{PD}	CE Pull-down Constant Current			0.3	0.8	μA	
V _{CEH} , V _{ECOH}	CE, ECO Input Voltage "H"		1		6	V	
V _{CEL} , V _{ECOL}	CE, ECO Input Voltage "L"		0		0.4	V	
en	Output Noise	BW=10Hz to 100kHz		30		μVrms	
R _{LOW}	Low Output Nch Tr. ON Resistance (of B version)	V _{CE} =0V		50		Ω	

• Electrical Characteristics by Output Voltage

Output Voltage V_{OUT} (V)	Dropout Voltage V_{DIF} (mV)				
	Condition	V_{DIF} (ECO="H")		V_{DIF} (ECO="L")	
		Typ.	Max.	Typ.	Max.
$0.8V \leq V_{OUT} < 0.9V$	$I_{OUT}=150mA$	755	1100	795	1100
$0.9V \leq V_{OUT} < 1.0V$		675	950	715	960
$1.0V \leq V_{OUT} < 1.2V$		600	890	645	930
$1.2V \leq V_{OUT} < 1.5V$		490	730	520	770
$1.5V \leq V_{OUT} < 2.0V$		395	610	415	640
$2.0V \leq V_{OUT} < 2.6V$		310	440	315	445
$2.8V \leq V_{OUT} \leq 4.0V$		250	350	255	350

*Recommended Ceramic capacitor for Output:

General Example of External Components

Ceramic Capacitors:

TYPICAL APPLIATION

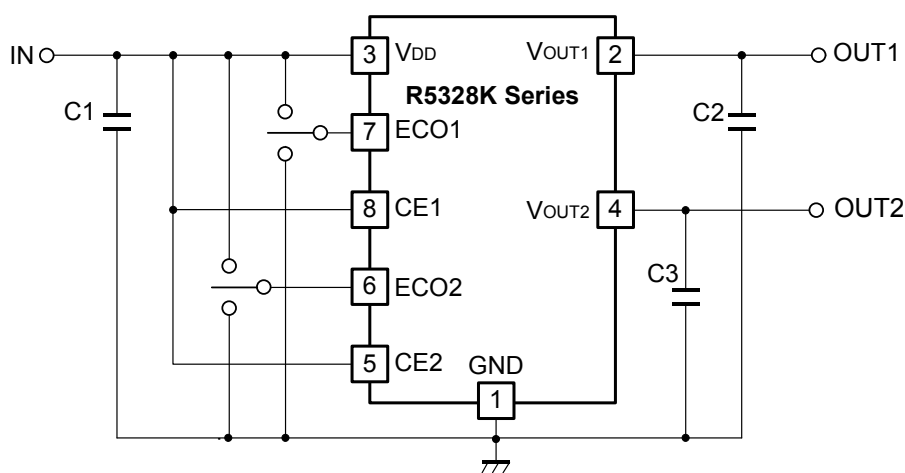

(External Components)

Output Capacitor; Ceramic Type

CM05X5R105K06AB (Kyocera)

C1005JB0J105K (TDK)

GRM155B30J105KE18B (Murata)

TEST CIRCUITS

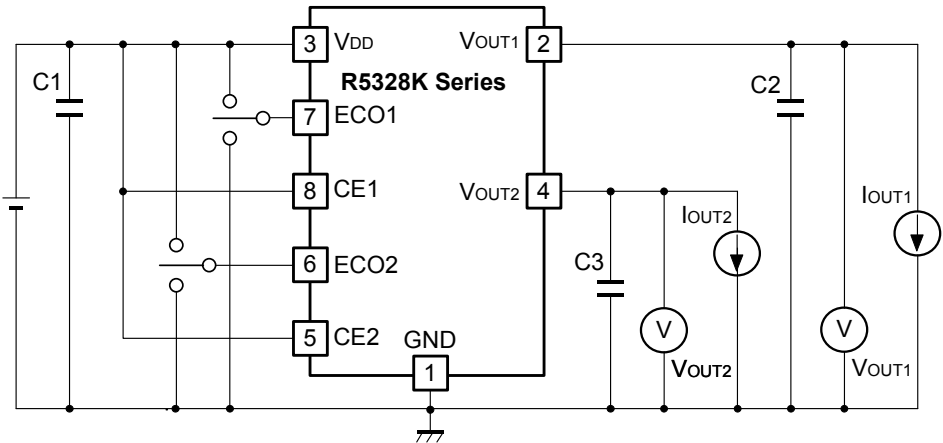

* C1=C2=C3=Ceramic 1.0μF

Standard test Circuit

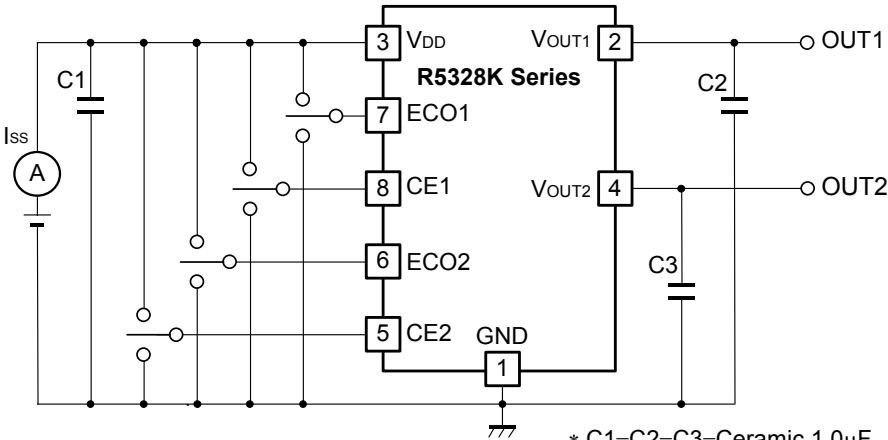

* C1=C2=C3=Ceramic 1.0μF

Supply Current Test Circuit

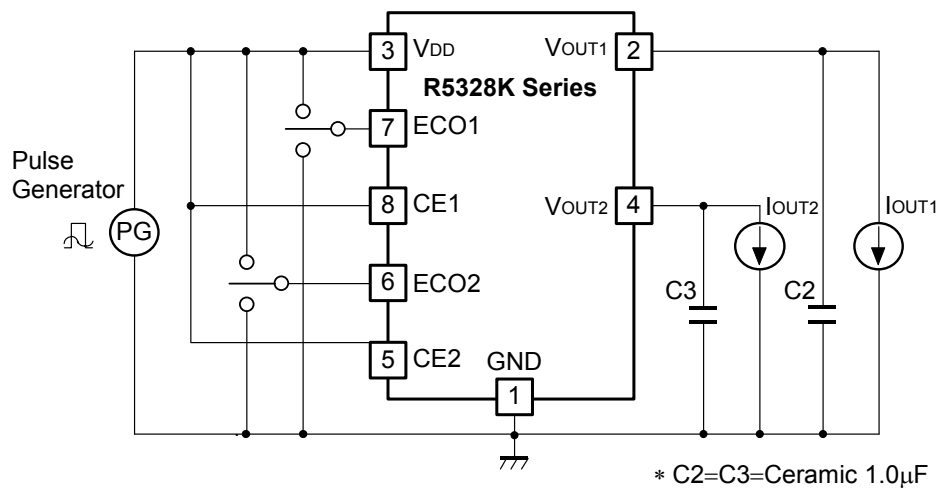

Ripple Rejection, Line Transient Response Test Circuit

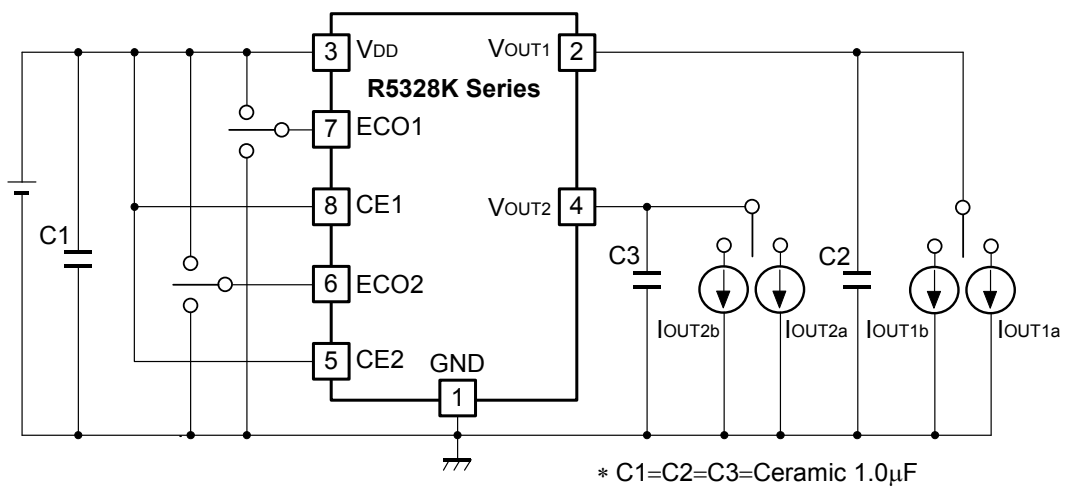

Load Transient Response Test Circuit

TYPICAL CHARACTERISTICS

1) Output Voltage vs. Output Current (T_{opt}=25°C)

0.8 V (VR1/VR2)

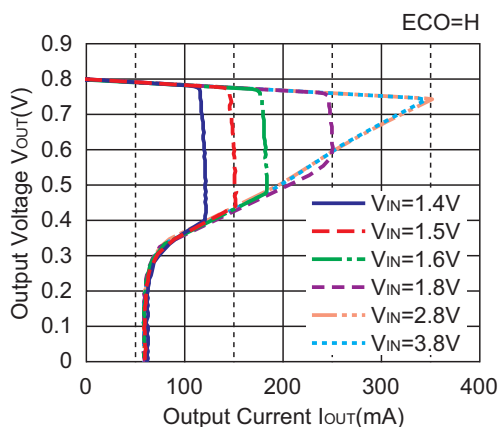

0.8V (VR1/VR2)

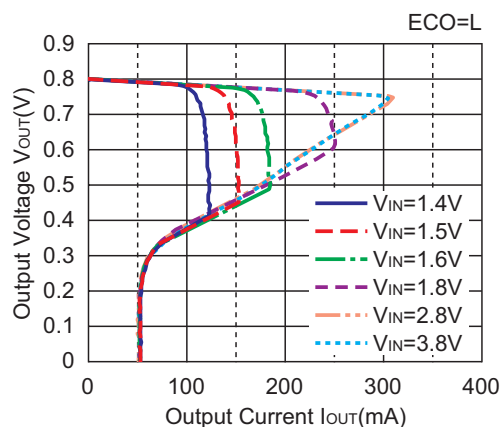

1.5V (VR1/VR2)

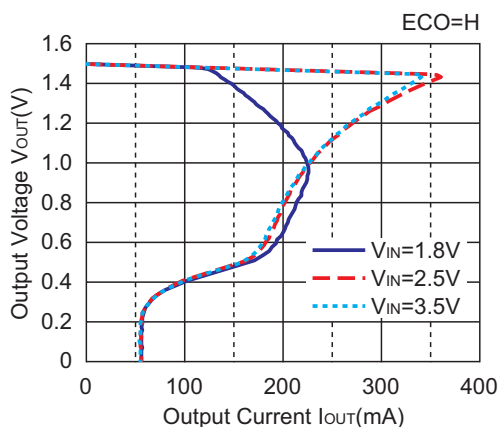

1.5V (VR1/VR2)

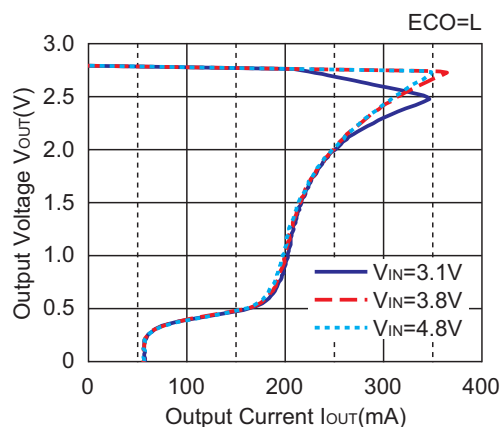

2.8V (VR1/VR2)

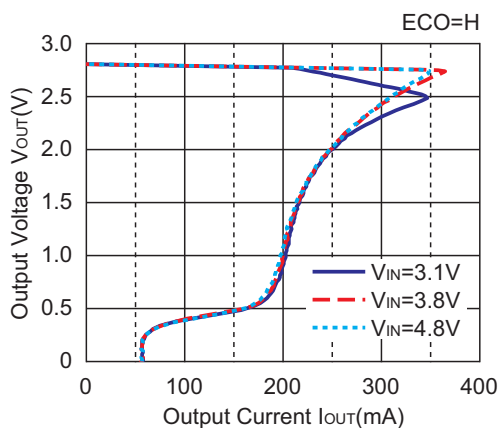

2.8V (VR1/VR2)

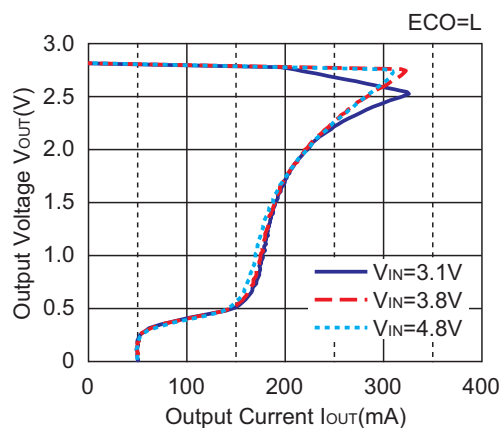

4.0V (VR1/VR2)

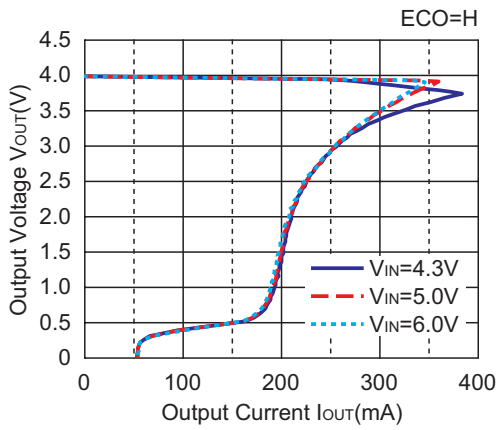

4.0V (VR1/VR2)

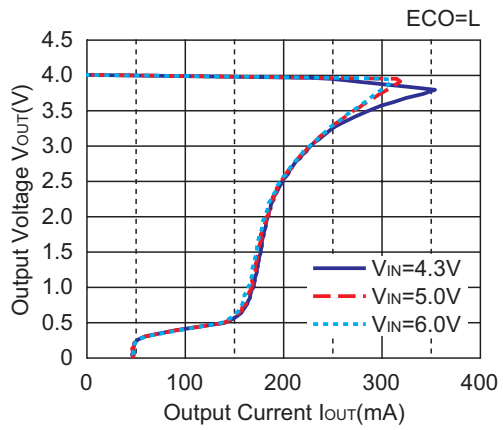

2) Output Voltage vs. Input Voltage (T_{opt}=25°C)

0.8V (VR1/VR2)

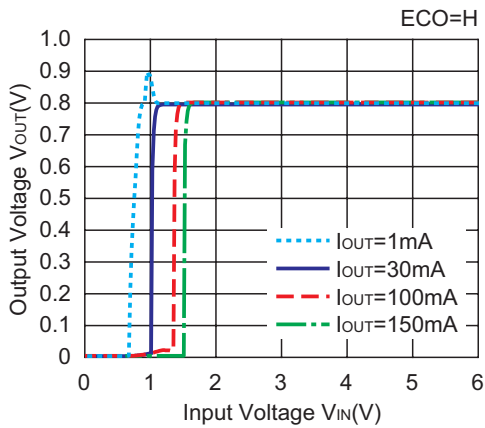

0.8V (VR1/VR2)

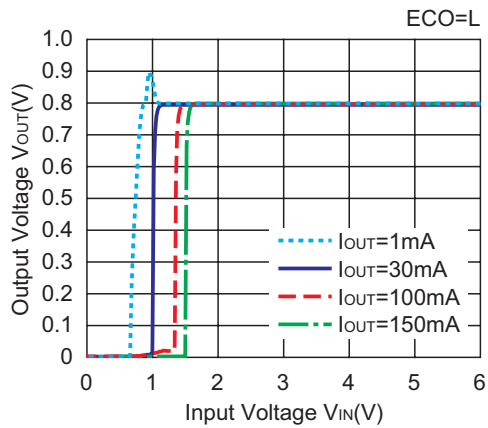

1.5V (VR1/VR2)

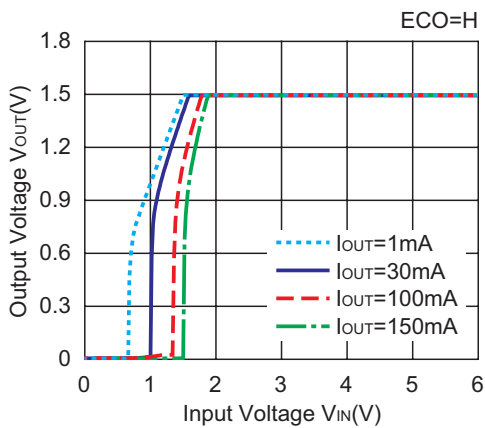

1.5V (VR1/VR2)

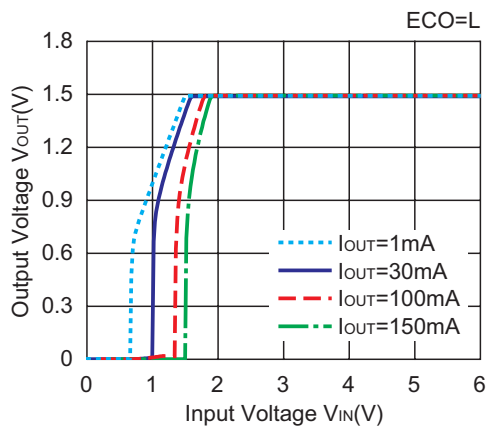

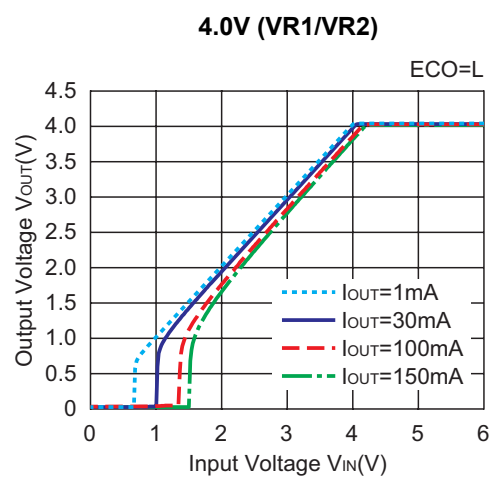
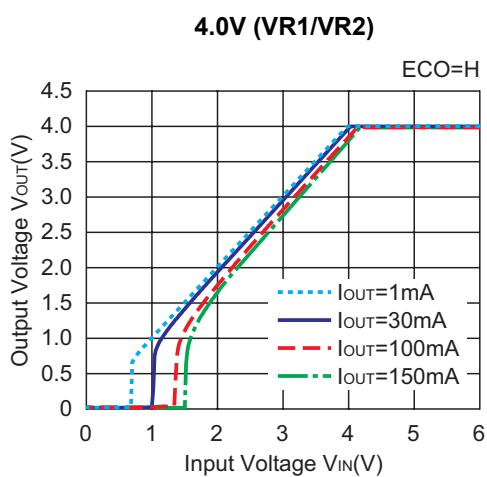
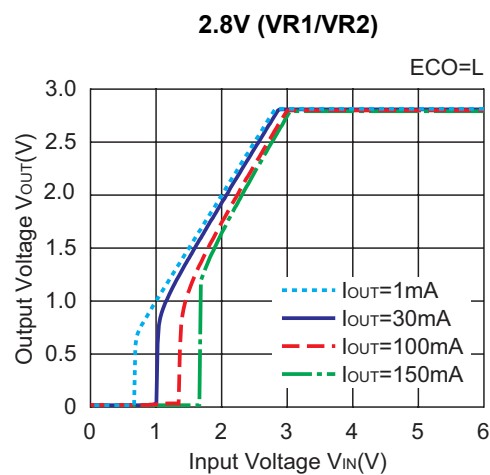
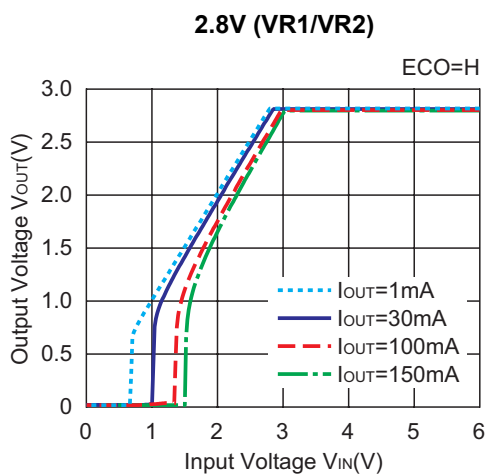

3) Supply Current vs. Input Voltage ($T_{opt}=25^{\circ}\text{C}$)

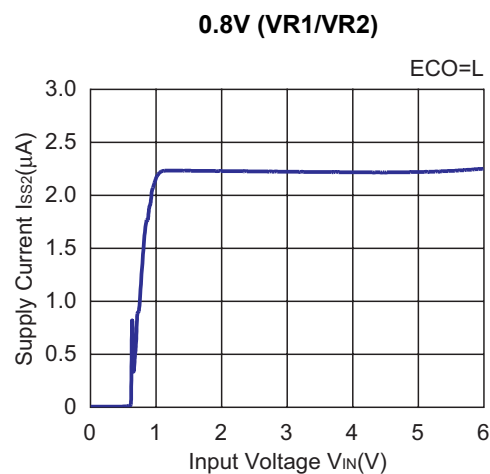
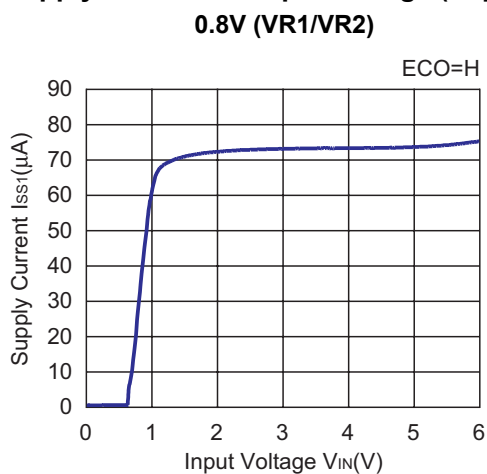

1.5V (VR1/VR2)

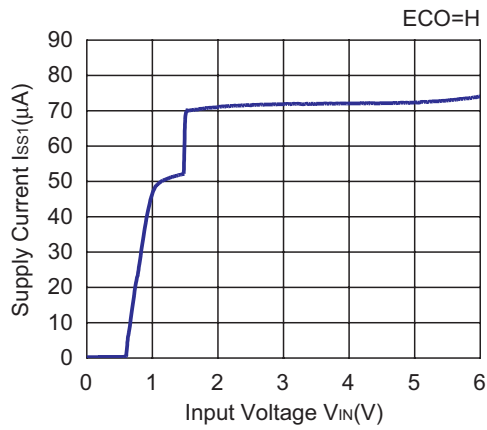

1.5V (VR1/VR2)

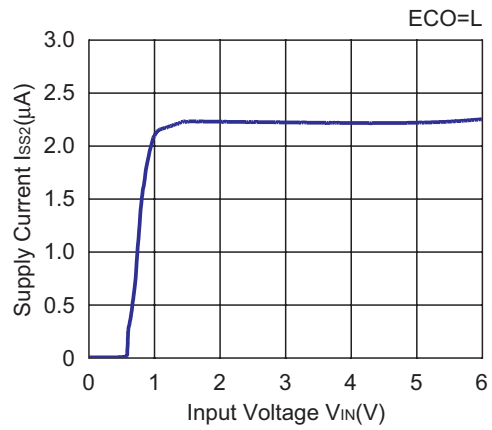

2.8V (VR1/VR2)

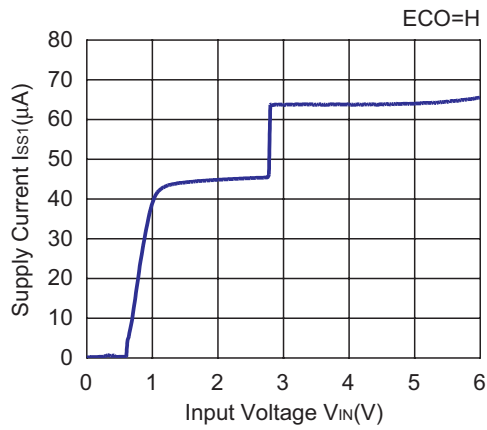

2.8V (VR1/VR2)

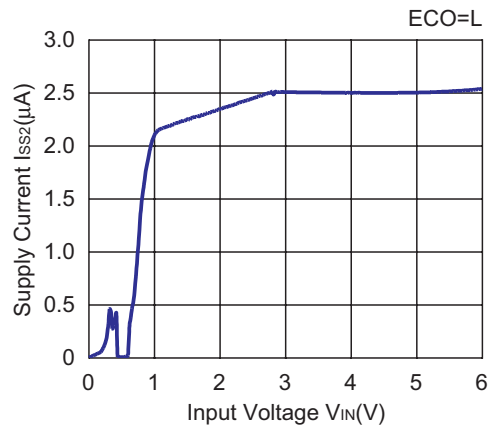

4.0V (VR1/VR2)

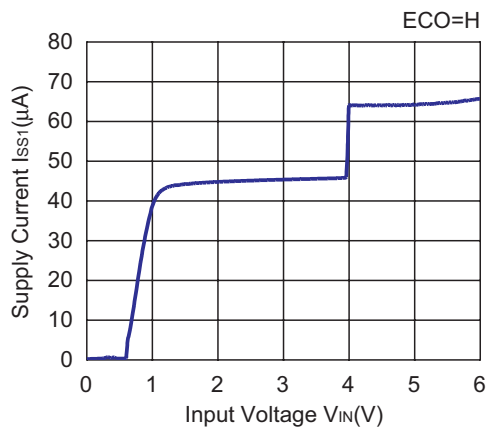

4.0V (VR1/VR2)

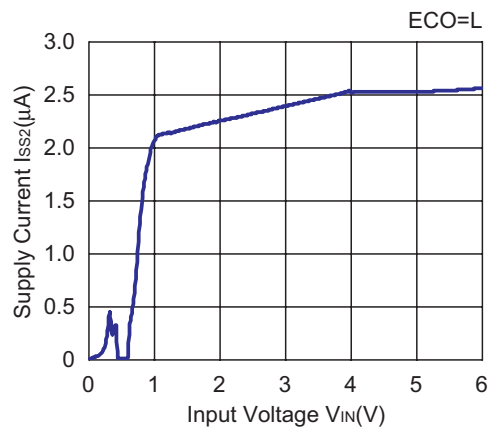

4) Output Voltage vs. Temperature

0.8V (VR1/VR2)

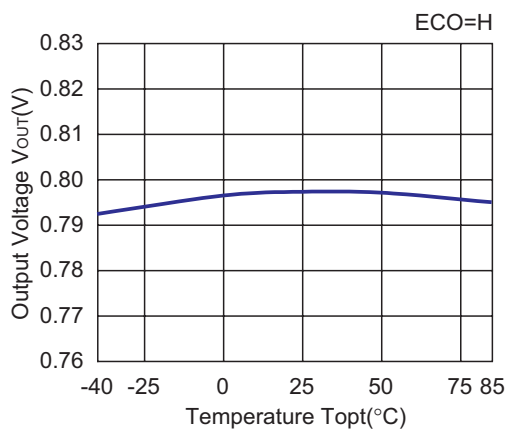

0.8V (VR1/VR2)

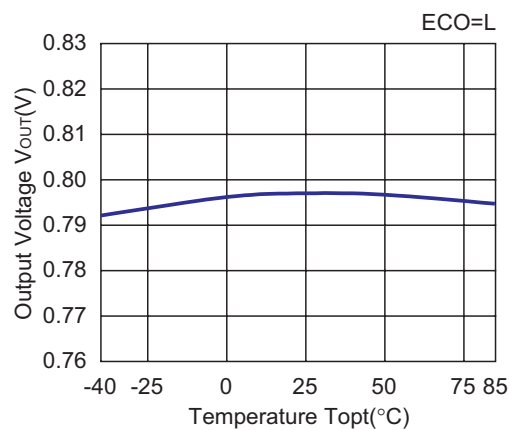

1.5V (VR1/VR2)

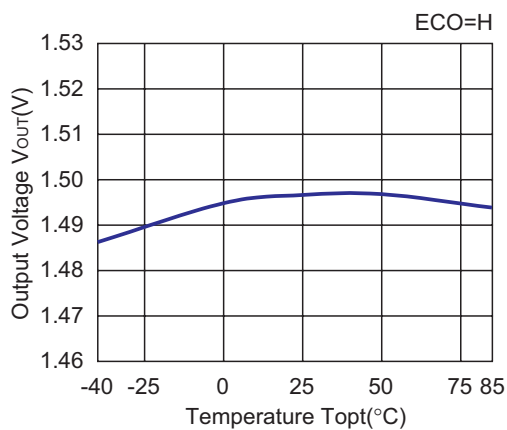

1.5V (VR1/VR2)

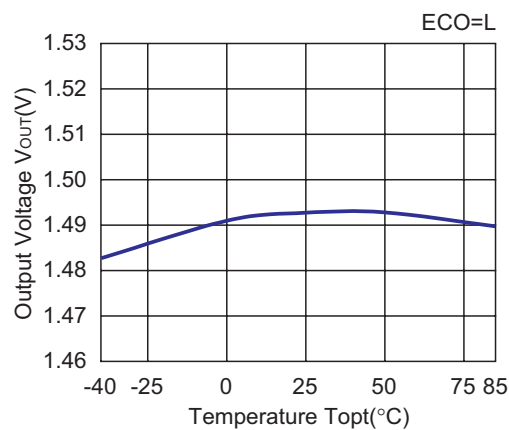

2.8V (VR1/VR2)

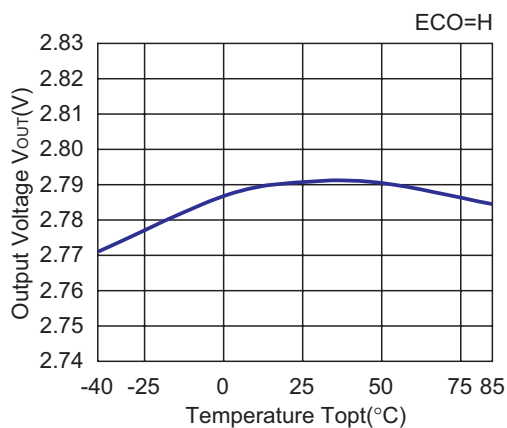

2.8V (VR1/VR2)

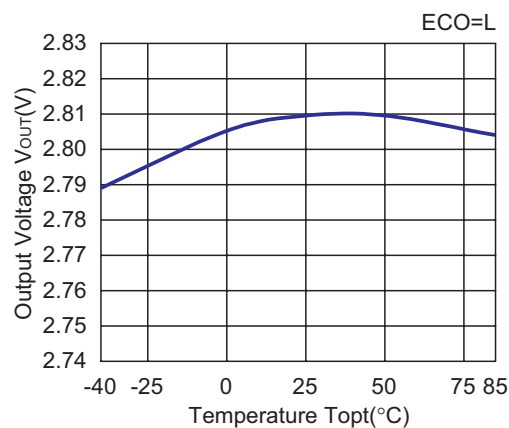

4.0V (VR1/VR2)

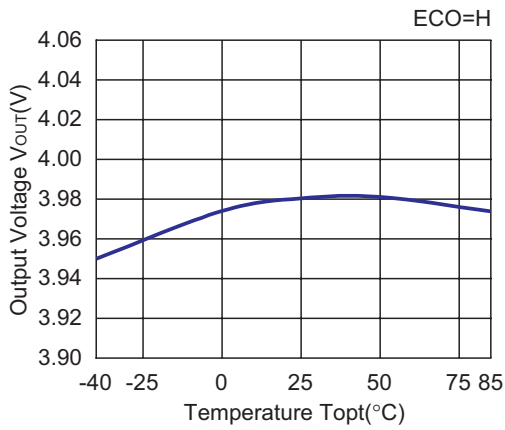

4.0V (VR1/VR2)

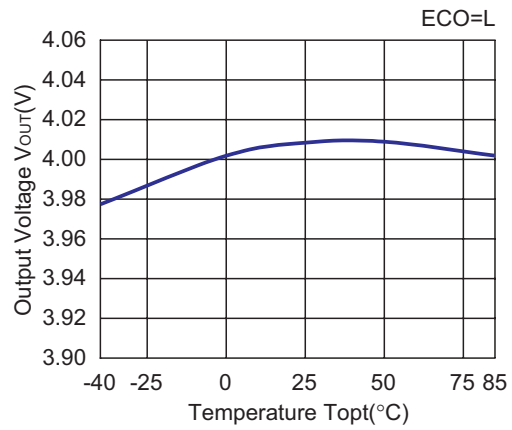

5) Supply Current vs. Temperature

0.8V (VR1/VR2)

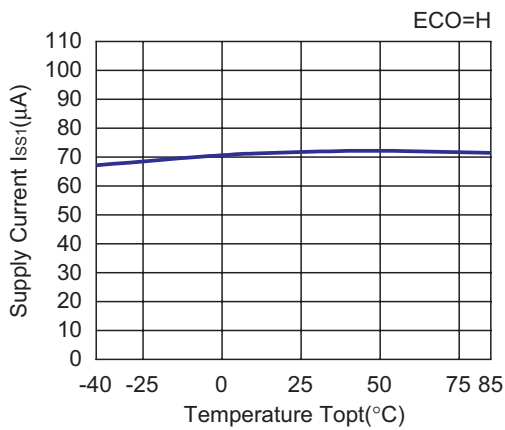

0.8V (VR1/VR2)

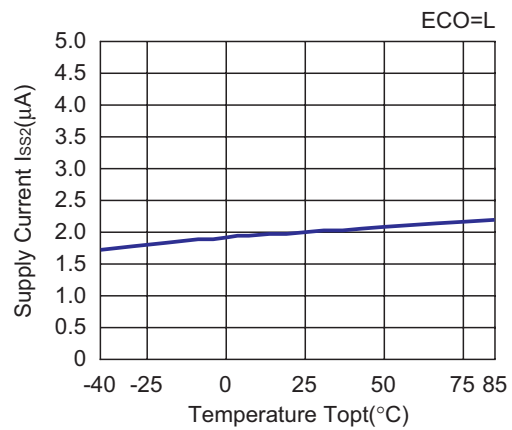

1.5V (VR1/VR2)

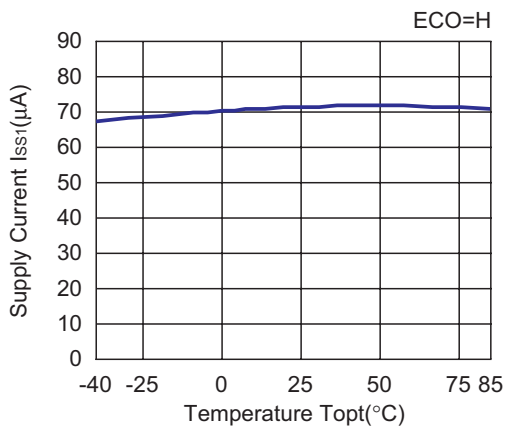

1.5V (VR1/VR2)

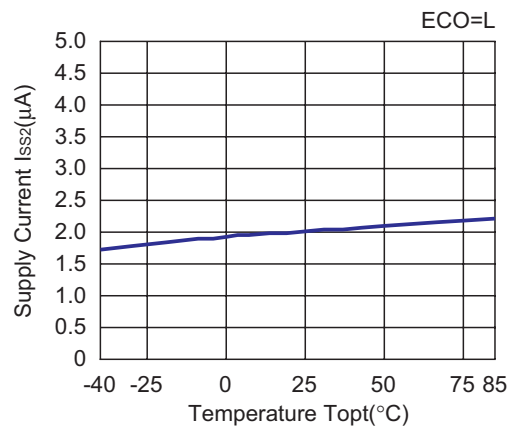

2.8V (VR1/VR2)

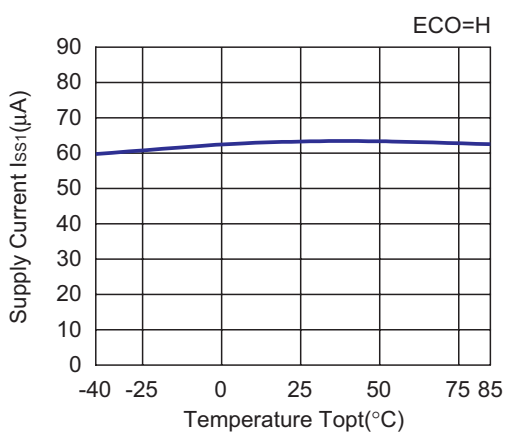

2.8V (VR1/VR2)

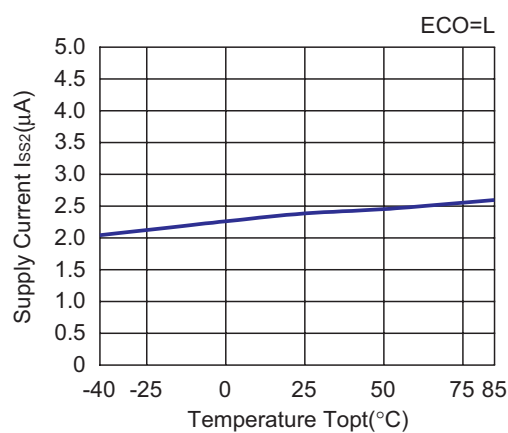

4.0V (VR1/VR2)

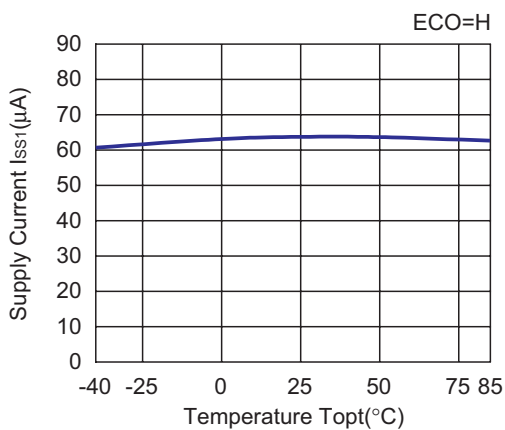

4.0V (VR1/VR2)

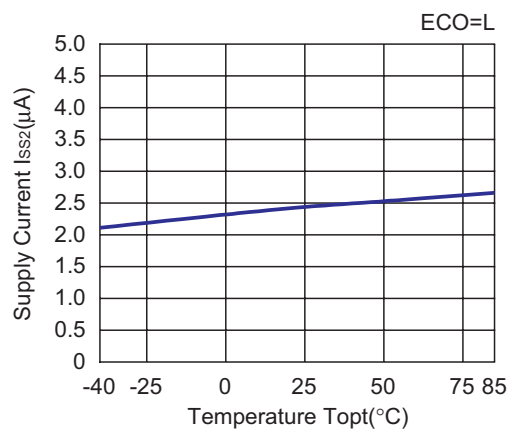

6) Dropout Voltage vs. Output Voltage

0.8V (VR1/VR2)

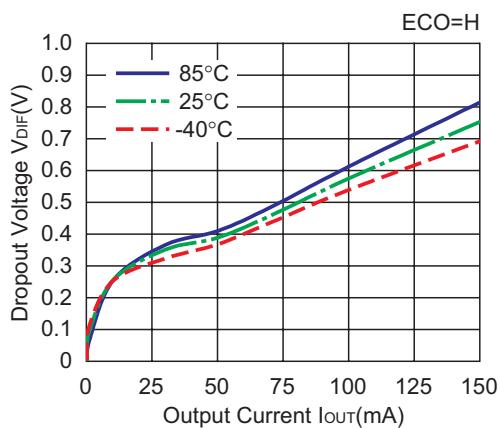

0.8V (VR1/VR2)

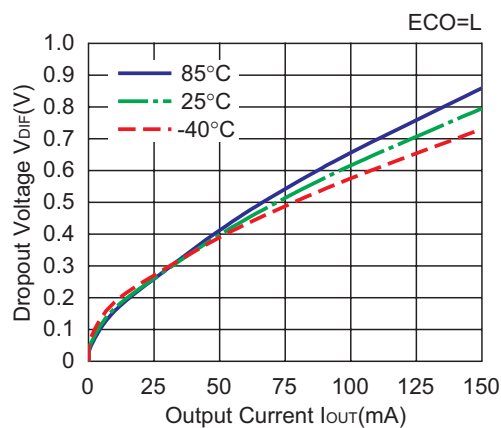

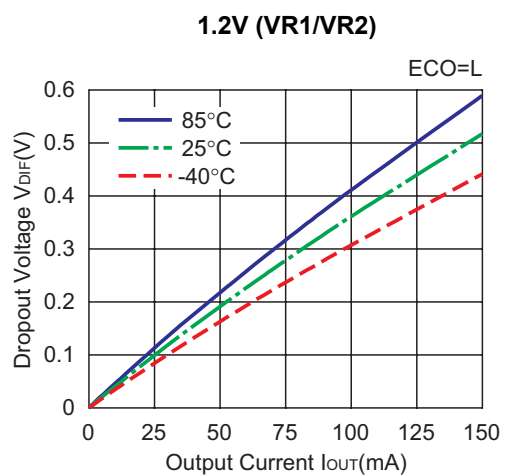
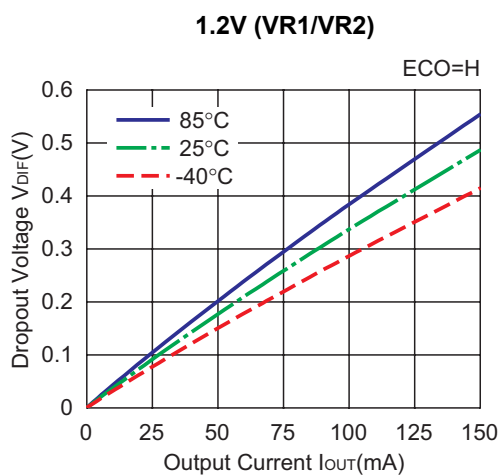
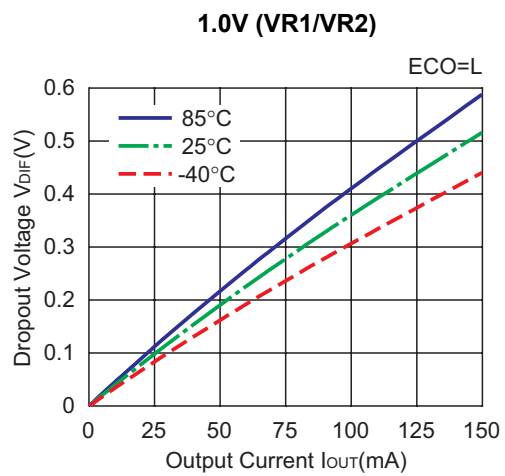
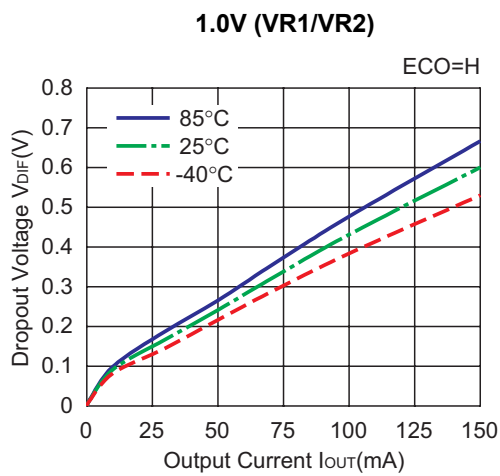
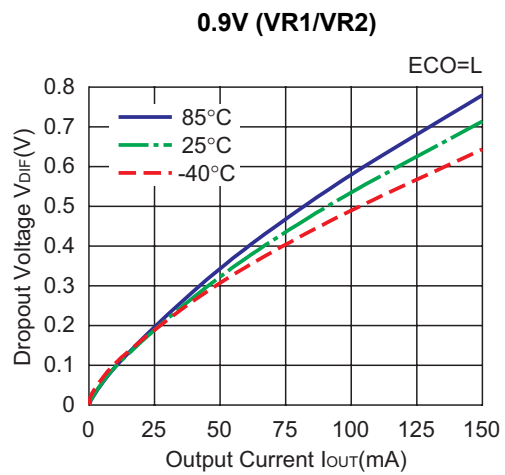
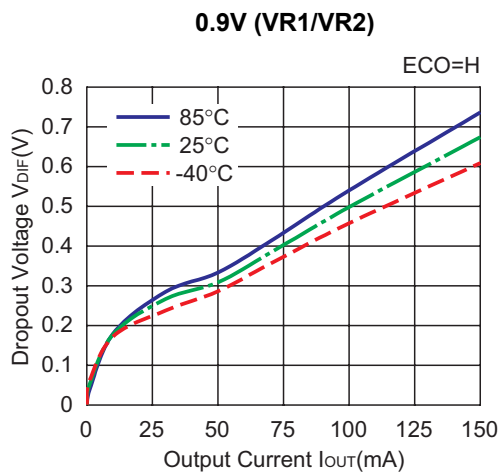

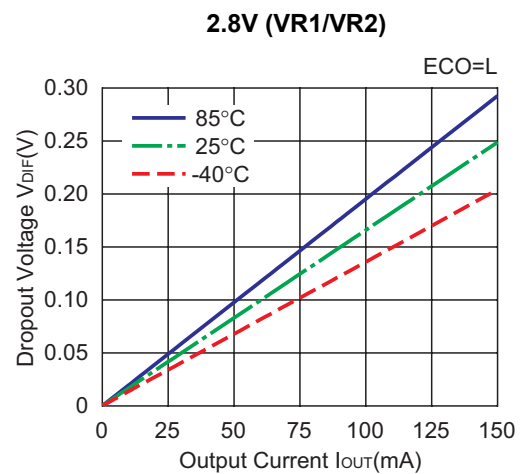
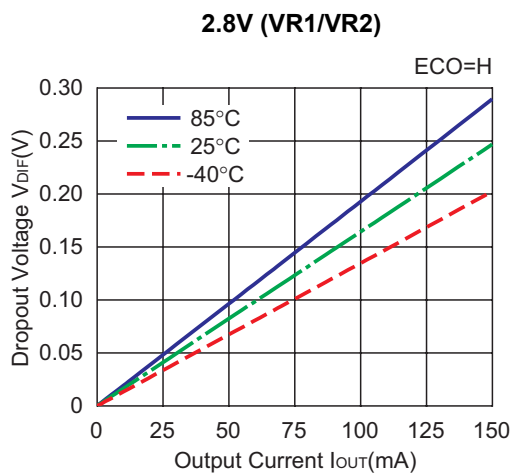
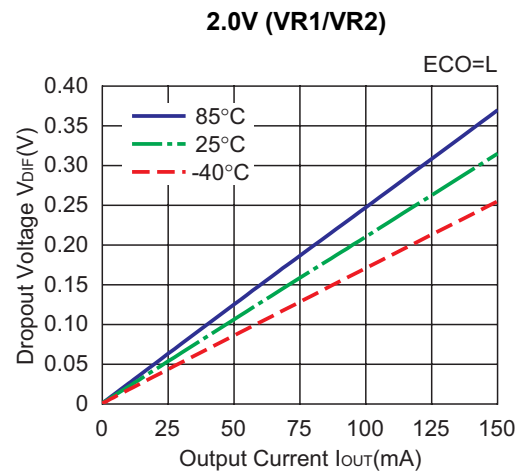
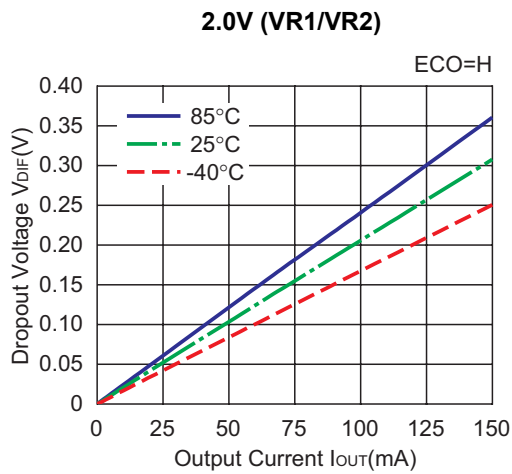
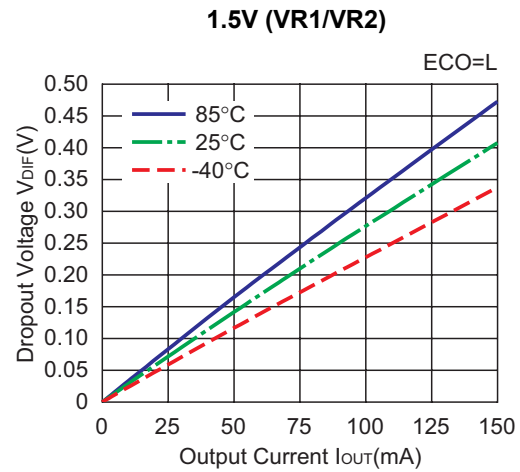
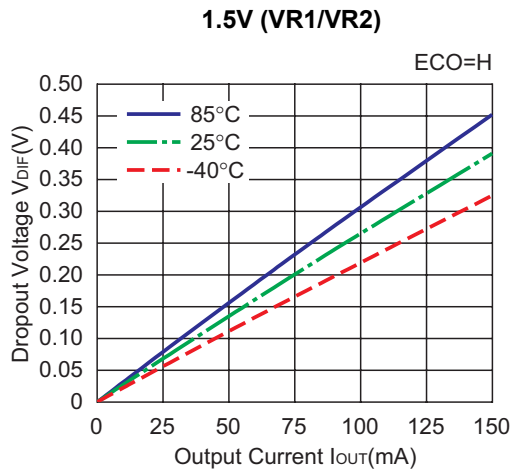

4.0V (VR1/VR2)

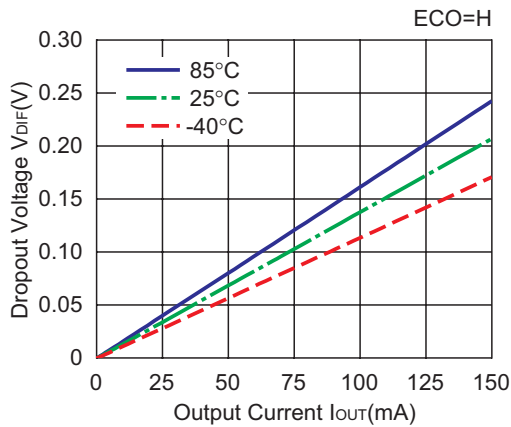

4.0V (VR1/VR2)

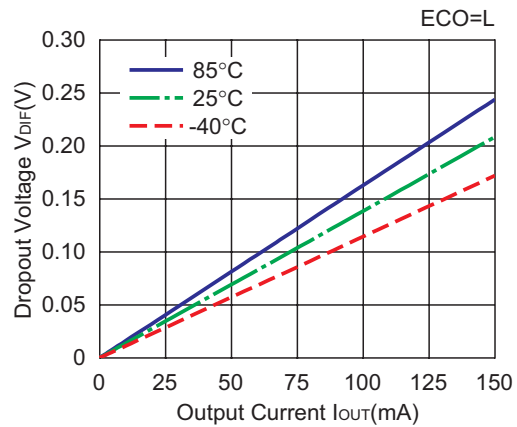

7) Dropout Voltage vs. Set Output Voltage (Topt=25°C)
R5328K (VR1/VR2)

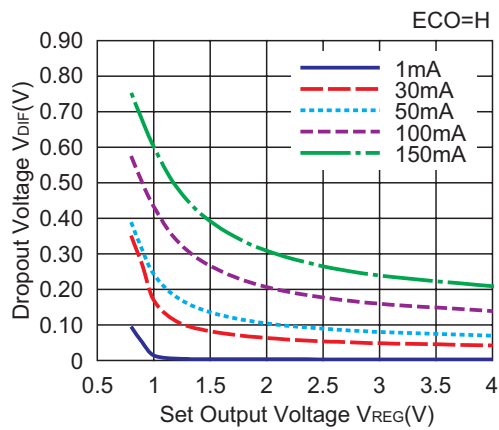

R5328K (VR1/VR2)

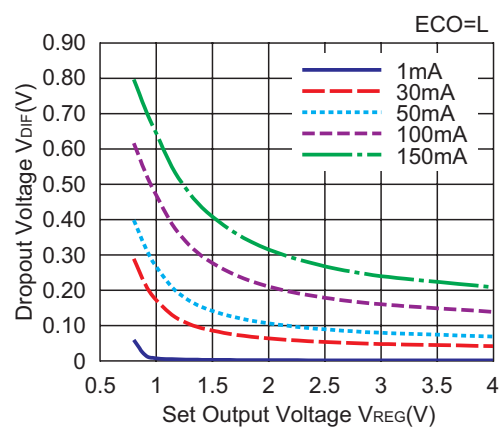

8) 0.8V (VR1/VR2) type minimum input voltage limit (Topt=25°C)

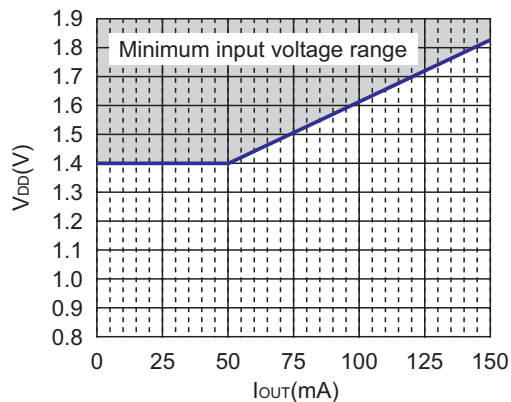

9) Ripple Rejection vs. Input Bias Voltage ($T_{opt}=25^{\circ}\text{C}$, $C_{IN}=\text{none}$, $C_{OUT}=\text{Ceramic } 1.0\mu\text{F}$, $\text{ECO}=\text{H}$)

2.8V (VR1/VR2)

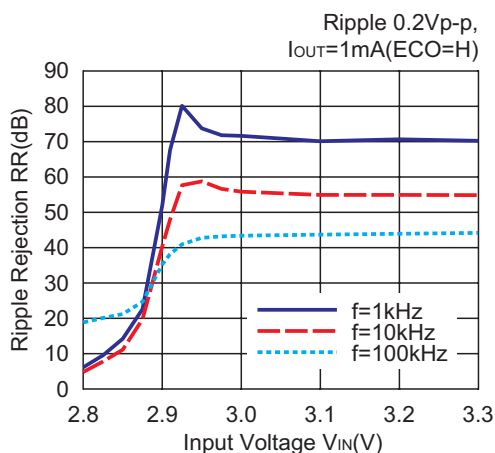

2.8V (VR1/VR2)

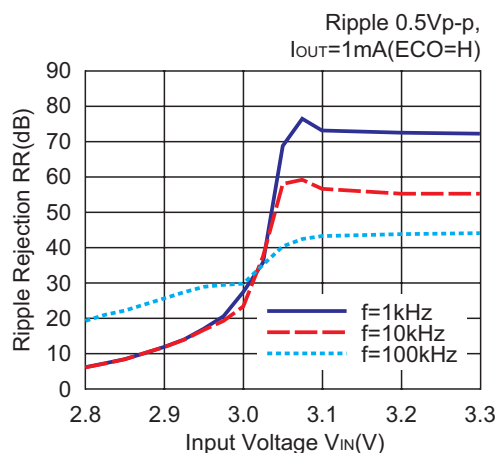

2.8V (VR1/VR2)

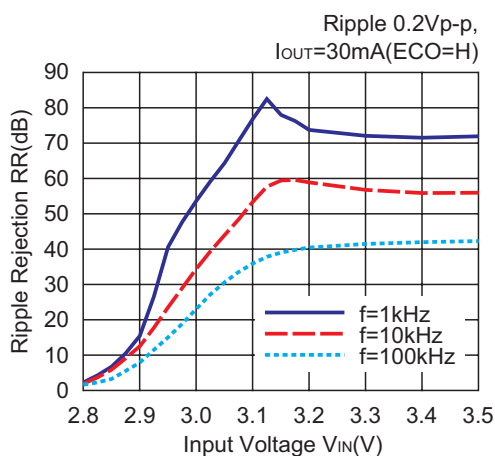

2.8V (VR1/VR2)

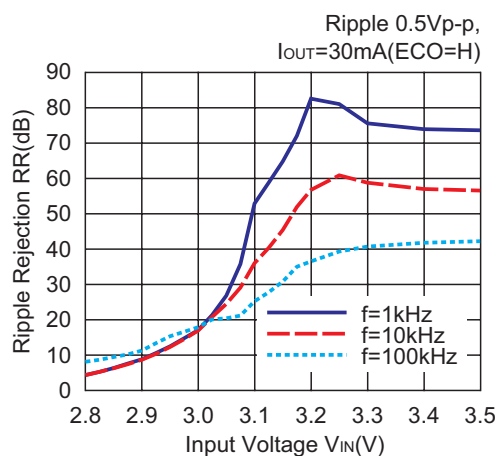

2.8V (VR1/VR2)

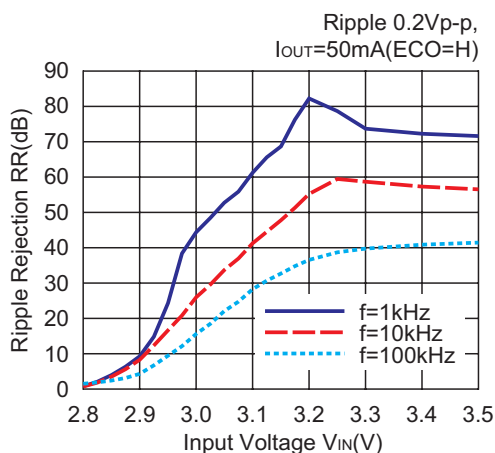

2.8V (VR1/VR2)

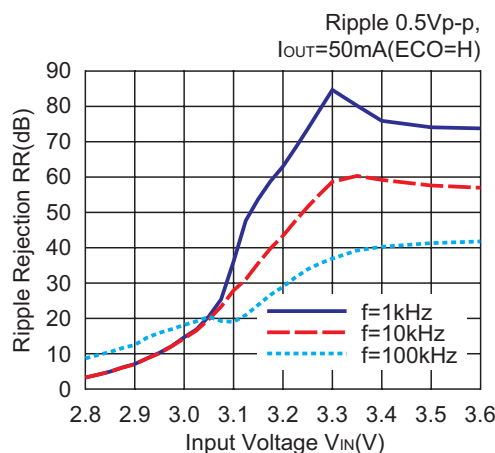

10) Ripple Rejection vs. Frequency (Topt=25°C, CIN=none)

0.8V (VR1/VR2)

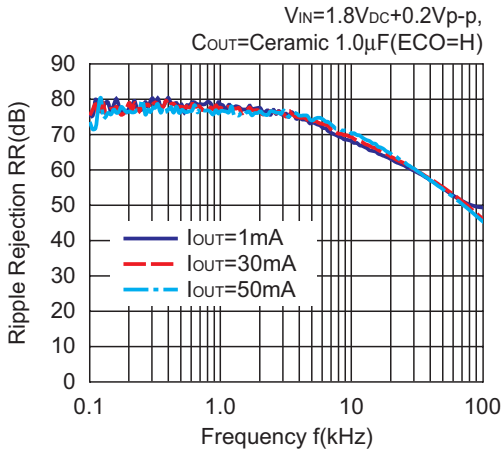

0.8V (VR1/VR2)

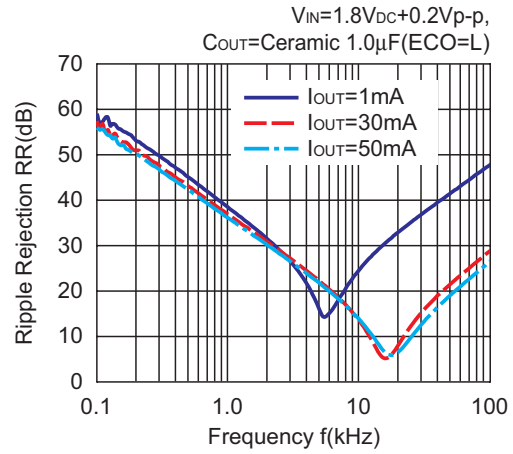

0.8V (VR1/VR2)

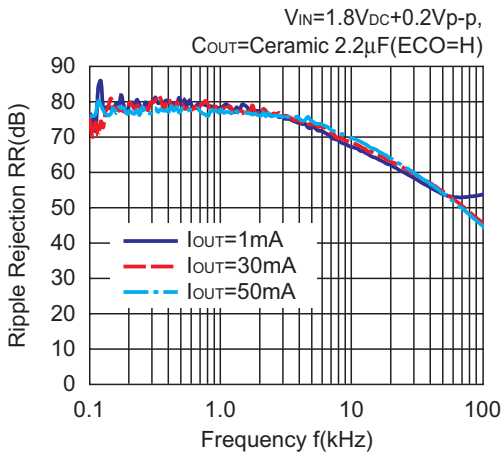

0.8V (VR1/VR2)

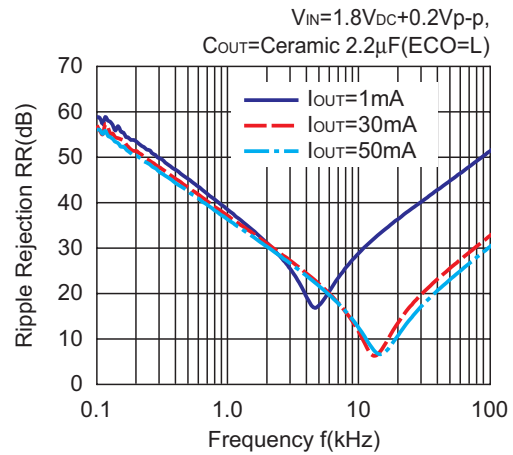

1.5V (VR1/VR2)

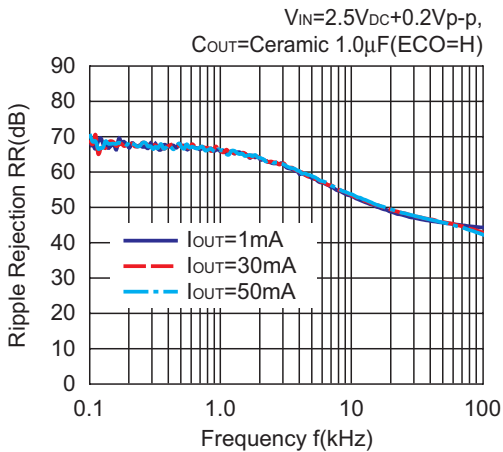

1.5V (VR1/VR2)

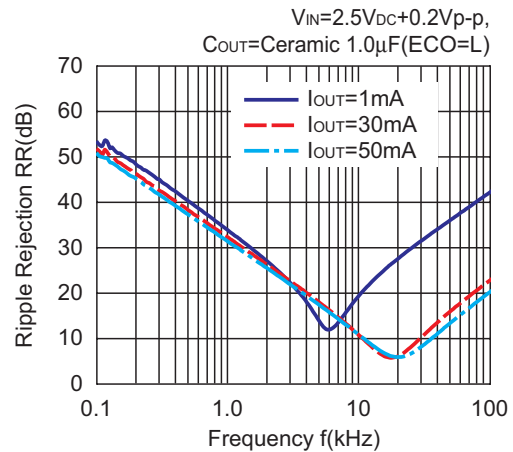

1.5V (VR1/VR2)

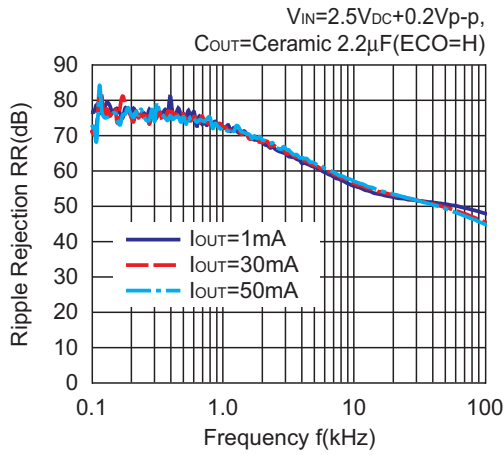

1.5V (VR1/VR2)

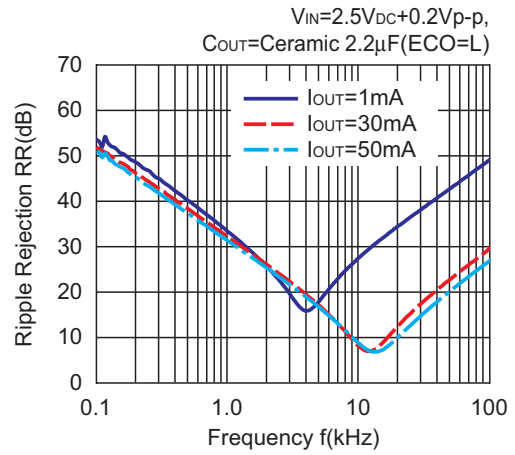

2.8V (VR1/VR2)

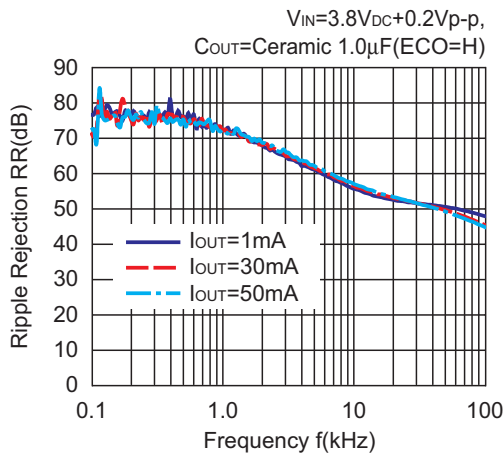

2.8V (VR1/VR2)

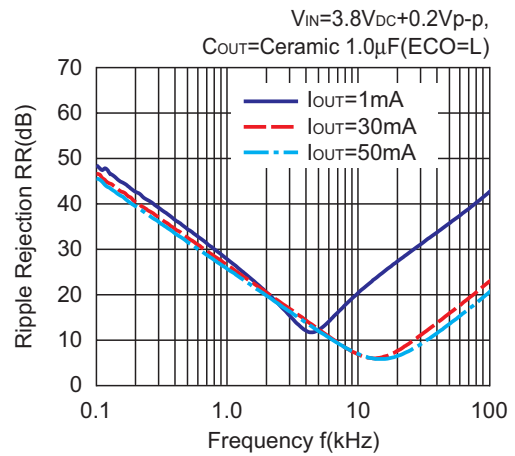

2.8V (VR1/VR2)

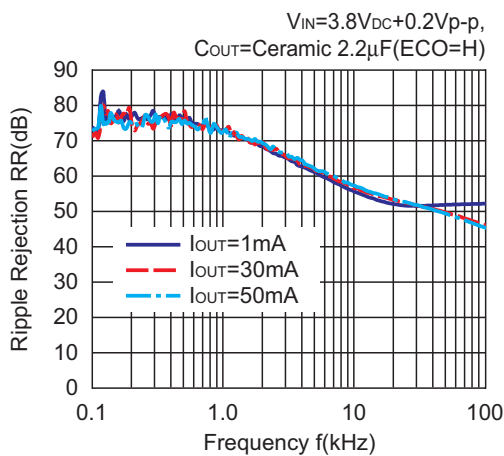

2.8V (VR1/VR2)

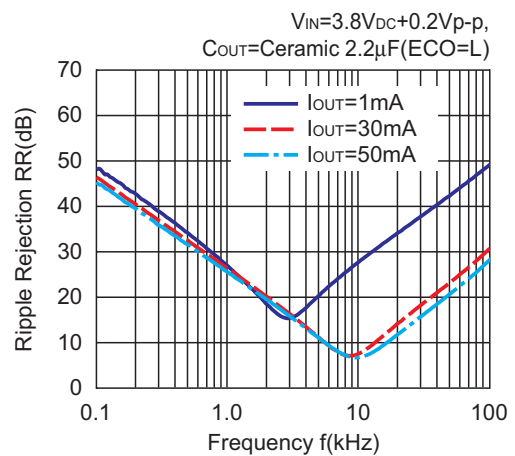

4.0V (VR1/VR2)

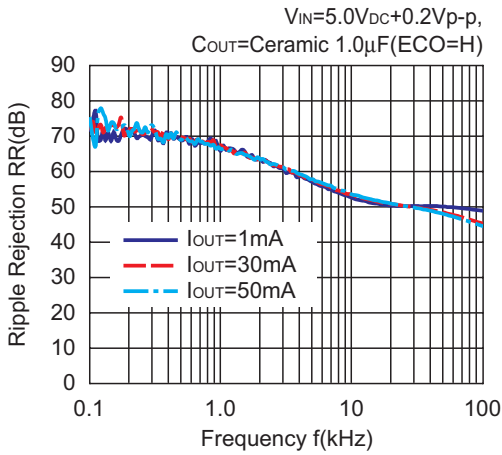

4.0V (VR1/VR2)

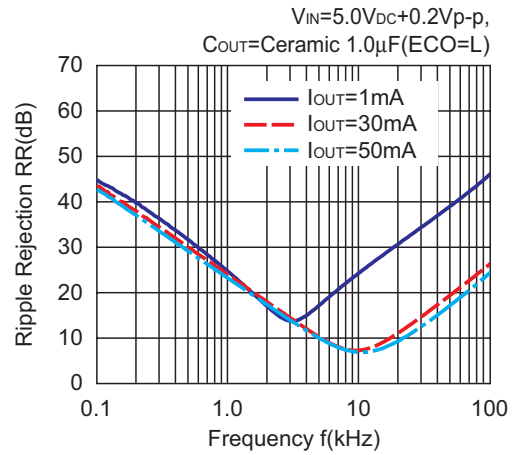

4.0V (VR1/VR2)

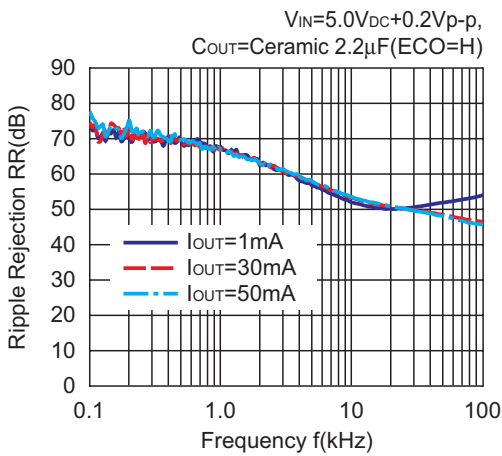

4.0V (VR1/VR2)

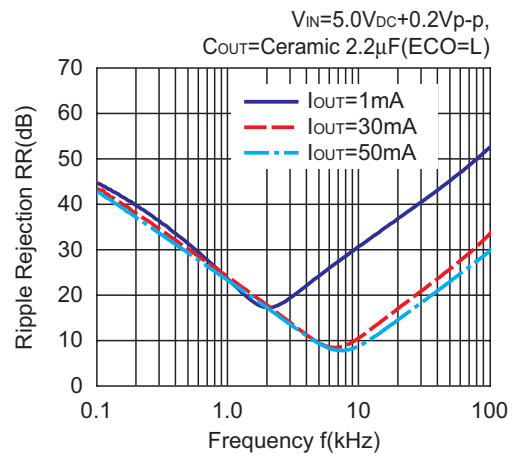

11) Input Transient Response ($C_{IN}=\text{none}$)

0.8V (VR1/VR2)

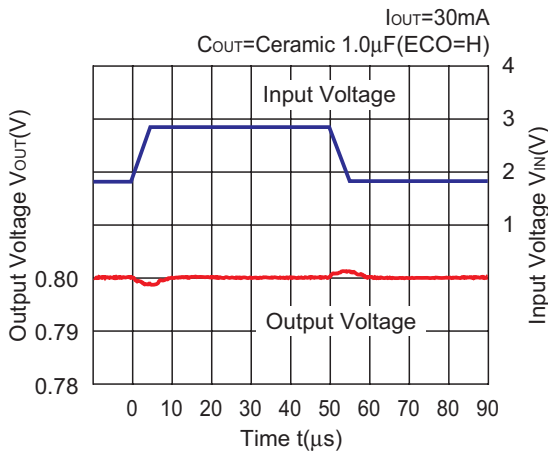

0.8V (VR1/VR2)

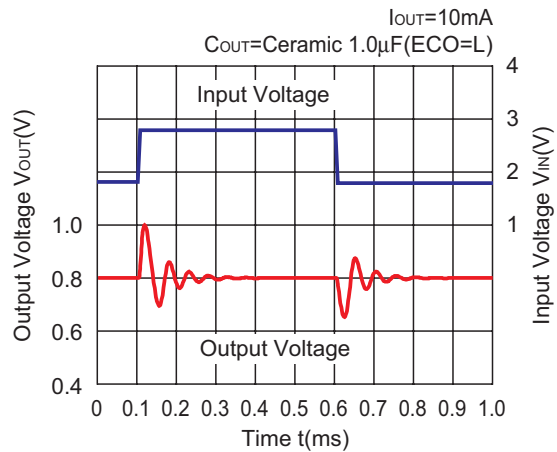

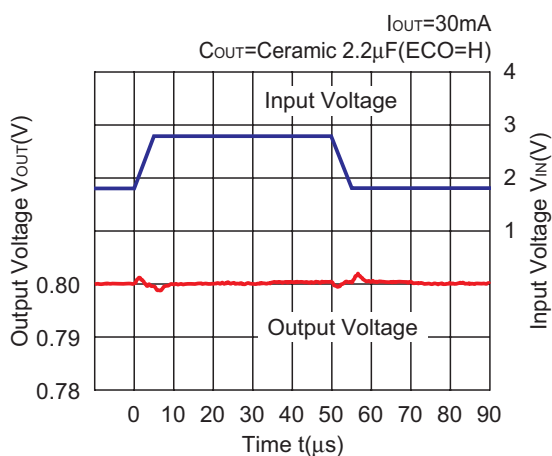
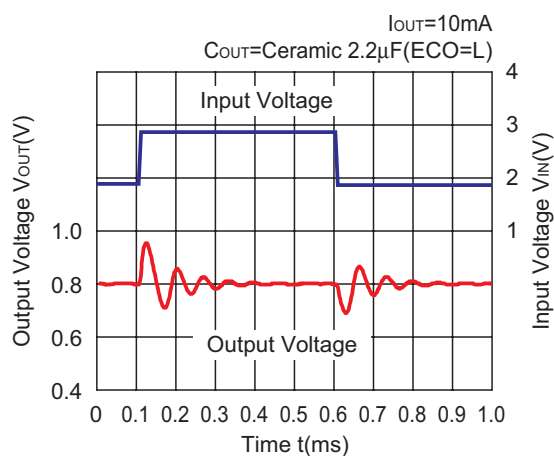
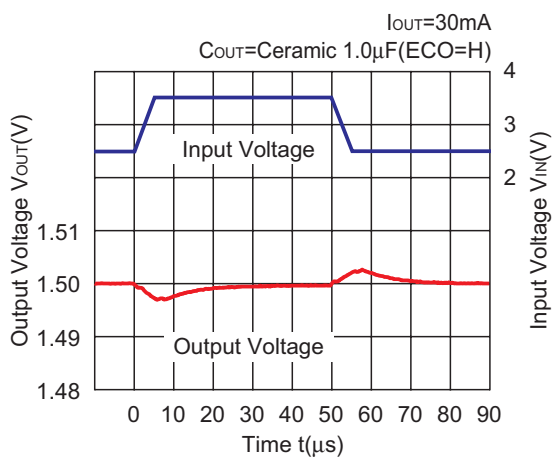
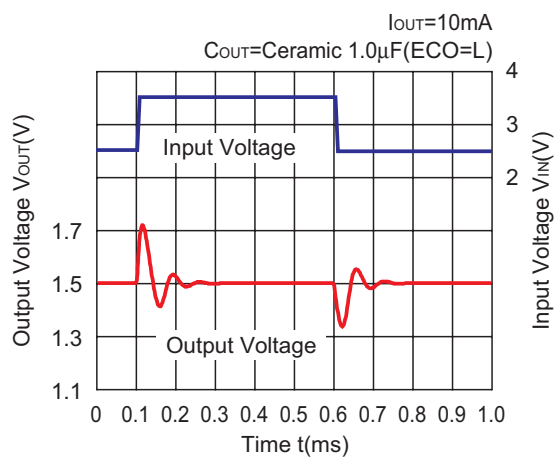
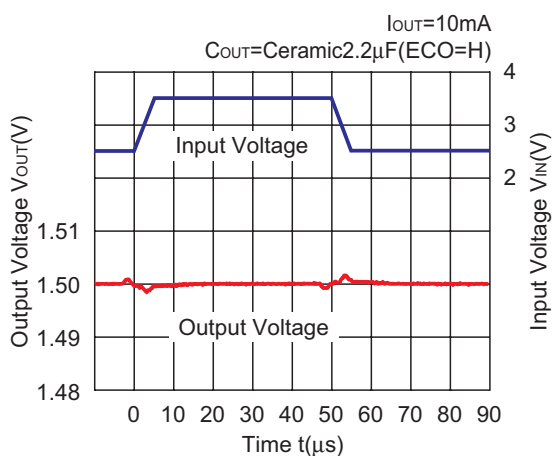
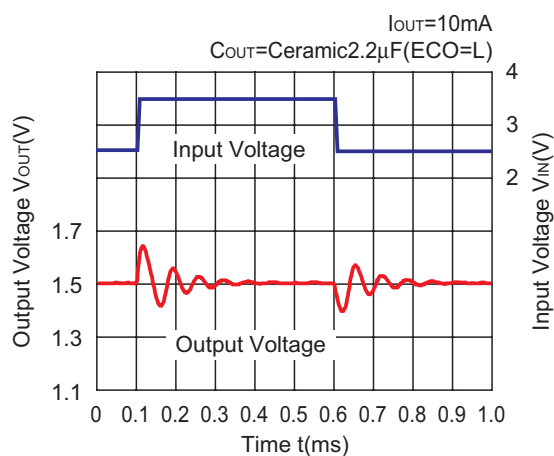
0.8V (VR1/VR2)**0.8V (VR1/VR2)****1.5V (VR1/VR2)****1.5V (VR1/VR2)****1.5V (VR1/VR2)****1.5V (VR1/VR2)**

2.8V (VR1/VR2)

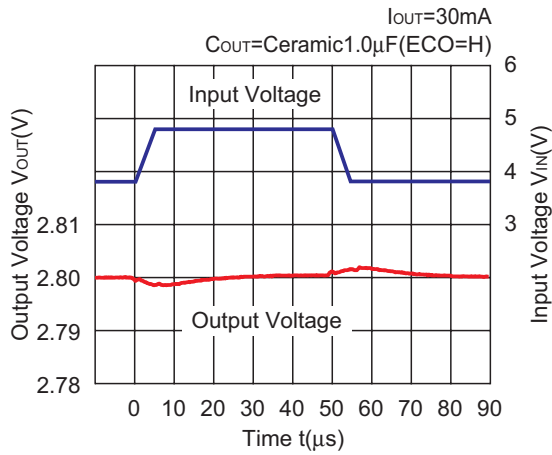

2.8V (VR1/VR2)

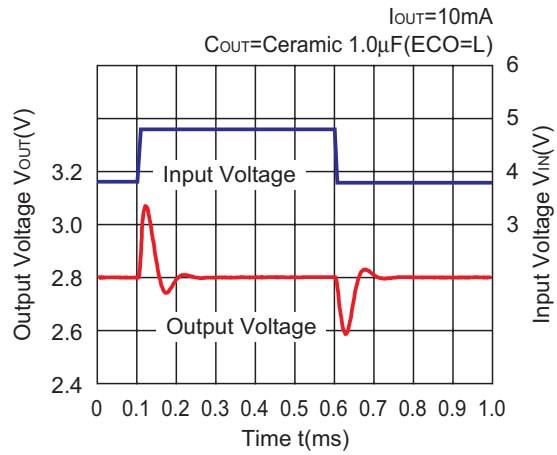

2.8V (VR1/VR2)

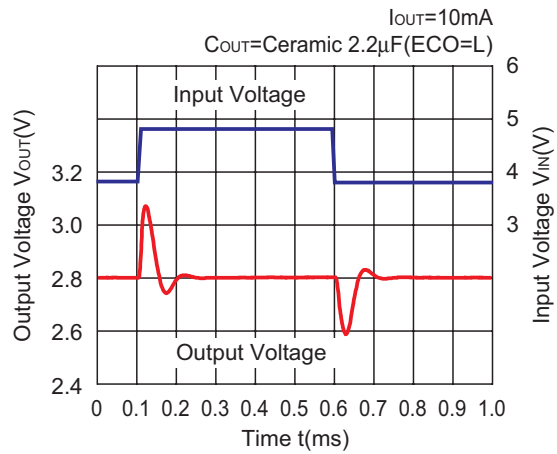

4.0V (VR1/VR2)

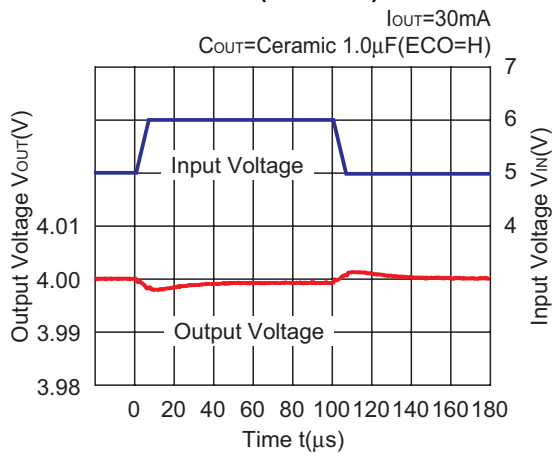

4.0V (VR1/VR2)

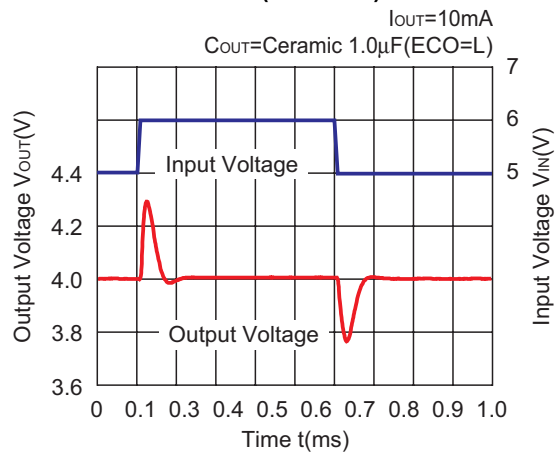

12) Load Transient Response (C_{IN} =Ceramic 1.0 μ F)

0.8V (VR1/VR2)

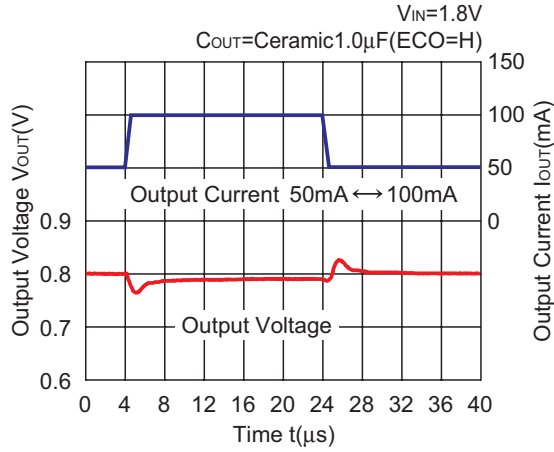

0.8V (VR1/VR2)

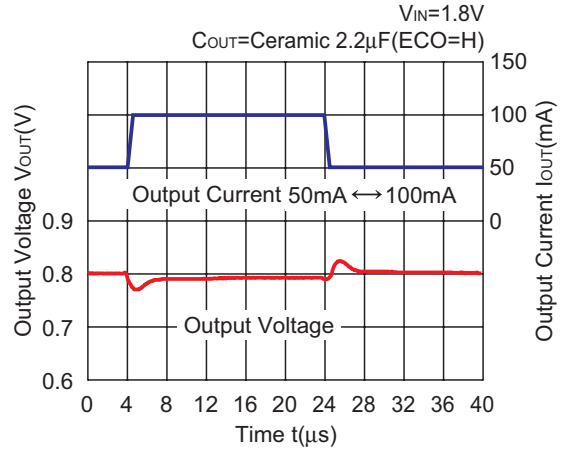

0.8V (VR1/VR2)

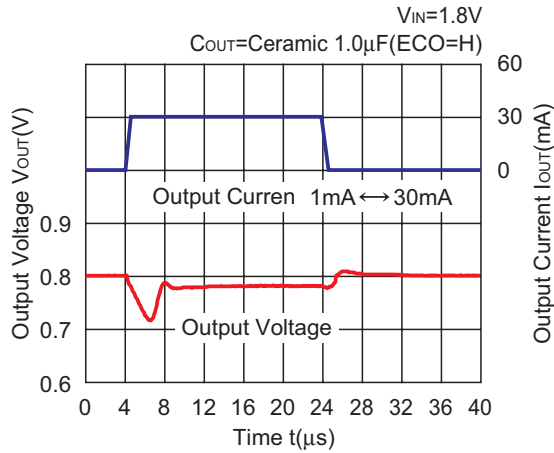

0.8V (VR1/VR2)

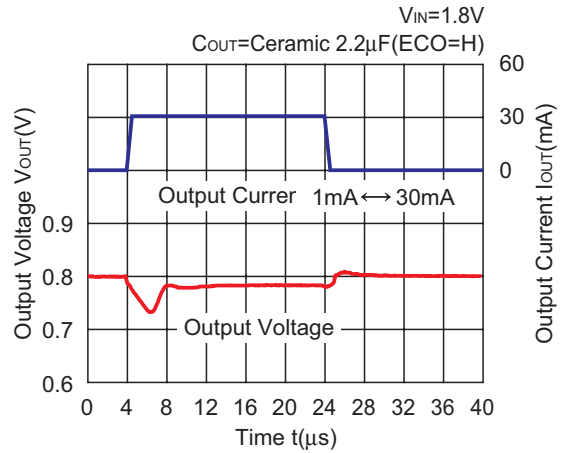

0.8V (VR1/VR2)

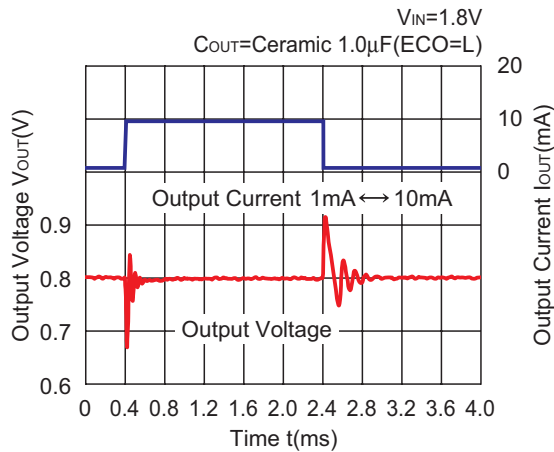

0.8V (VR1/VR2)

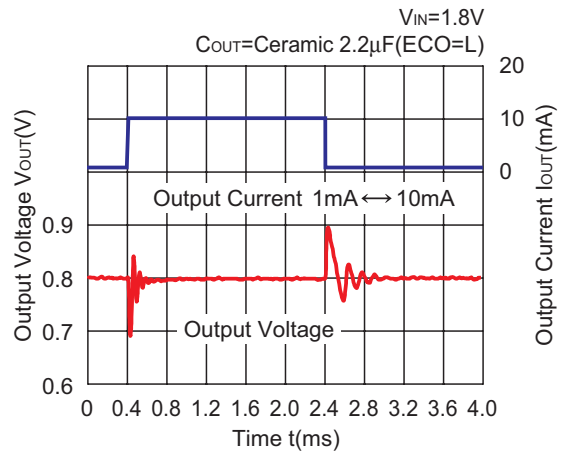

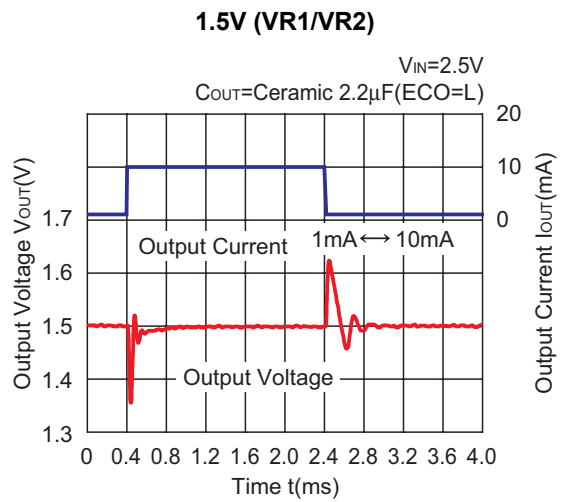
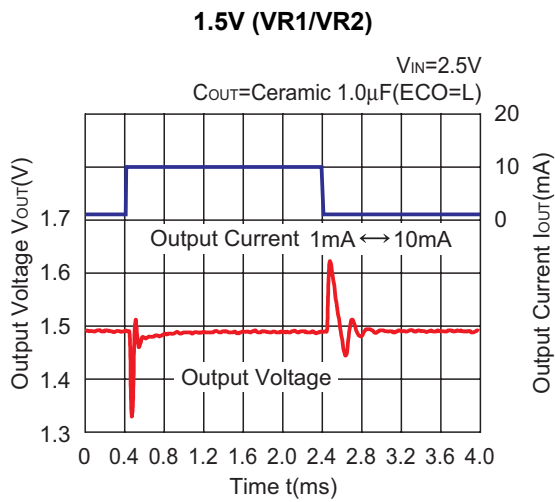
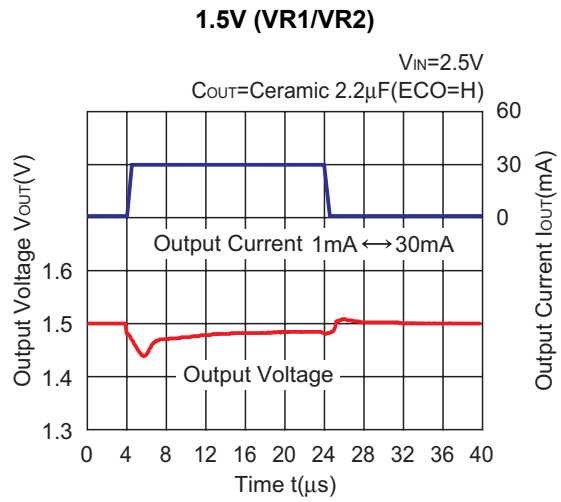
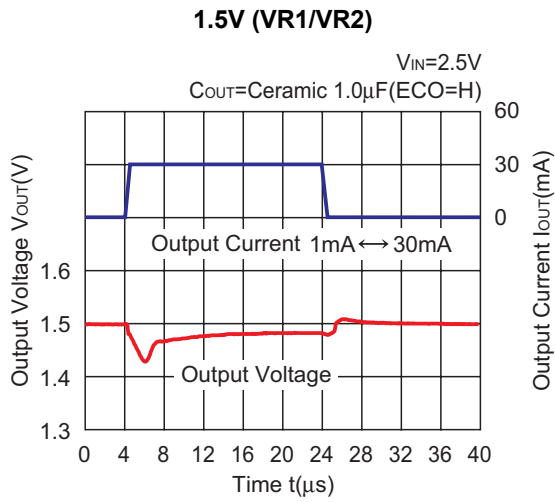
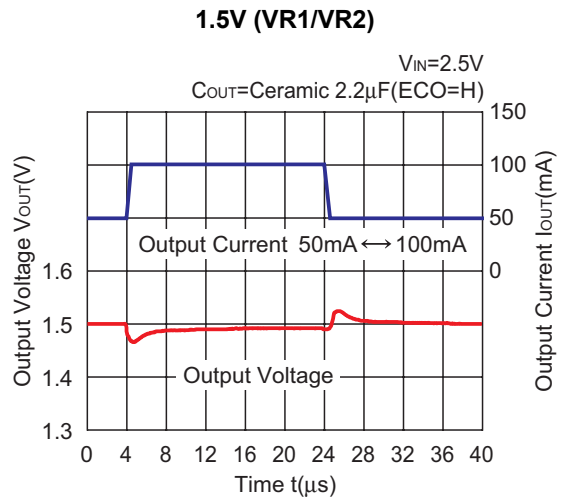
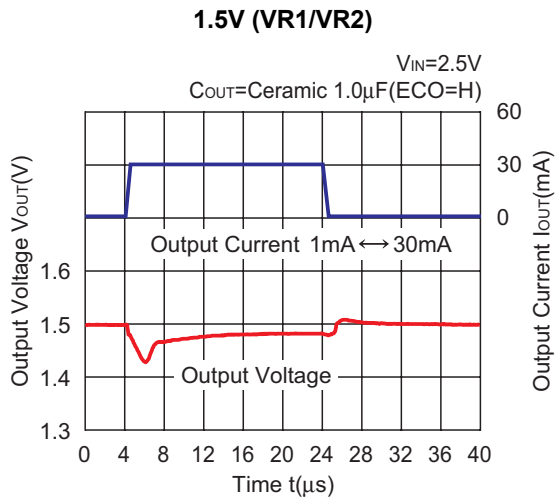

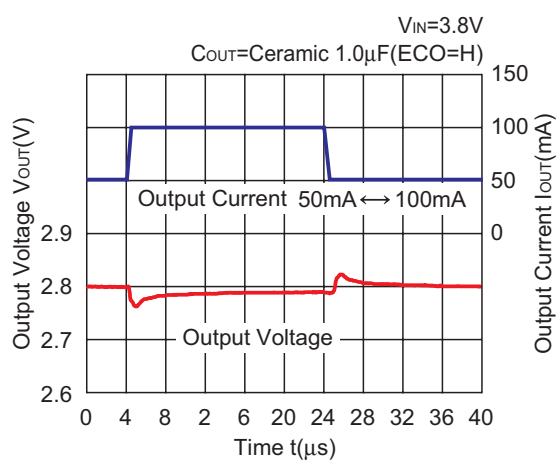
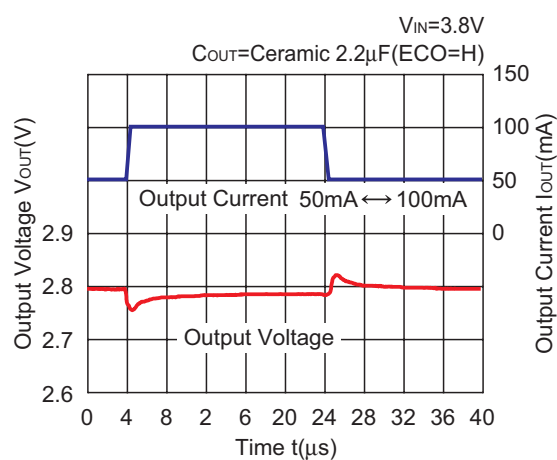
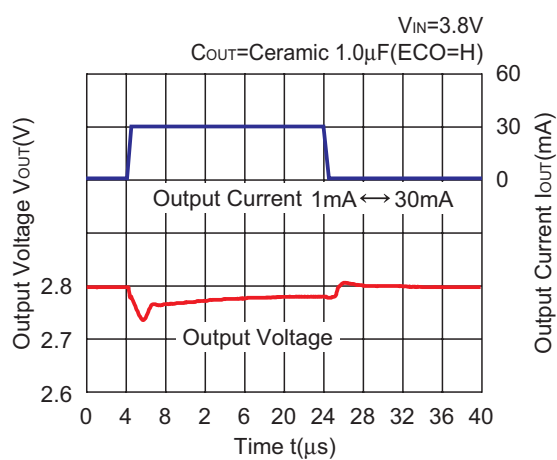
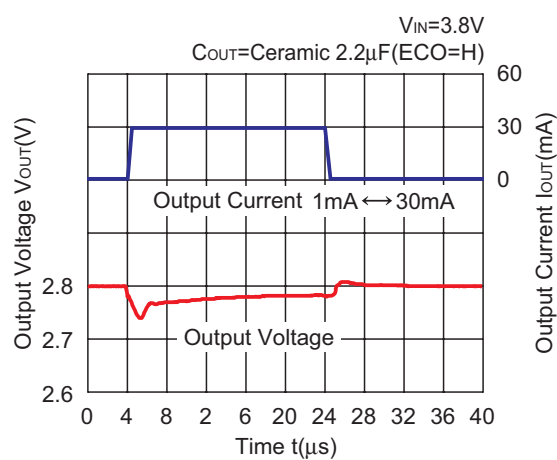
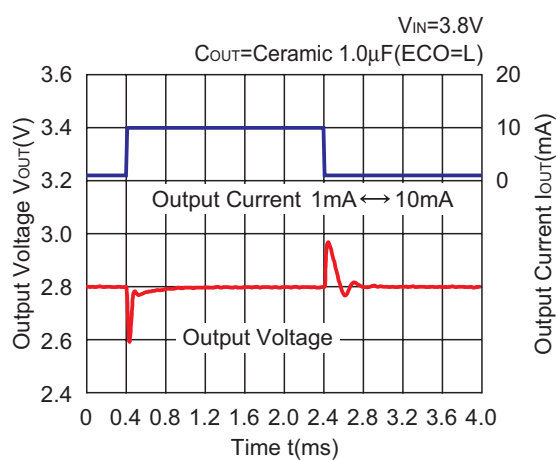
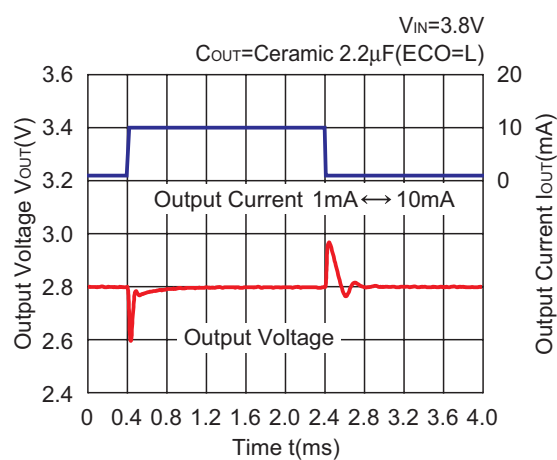
2.8V (VR1/VR2)**2.8V (VR1/VR2)****2.8V (VR1/VR2)****2.8V (VR1/VR2)****2.8V (VR1/VR2)****2.8V (VR1/VR2)**

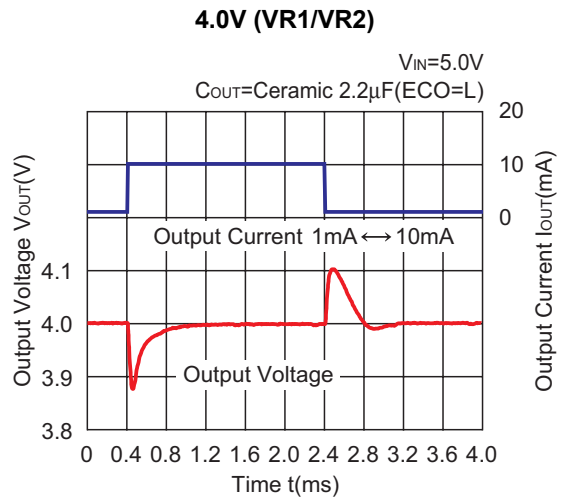
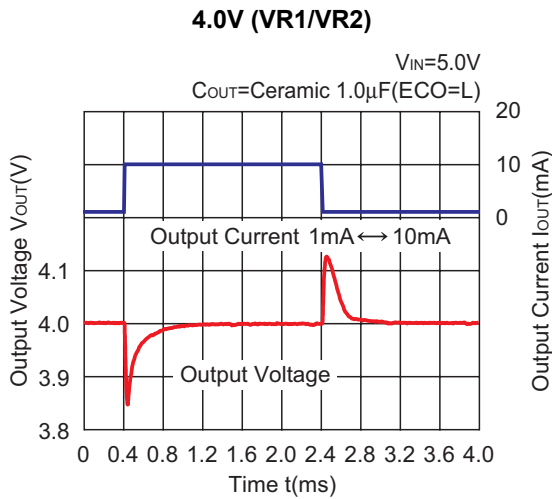
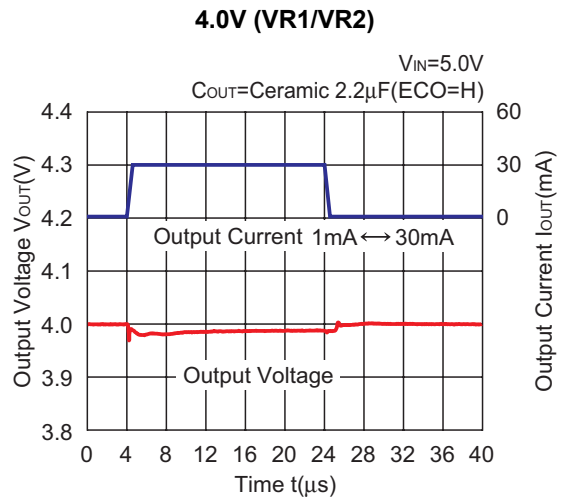
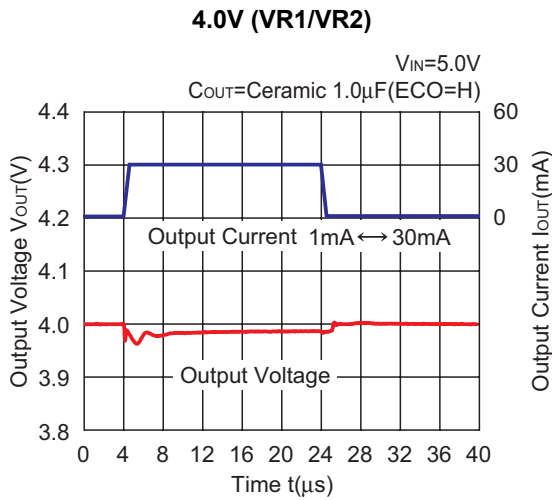
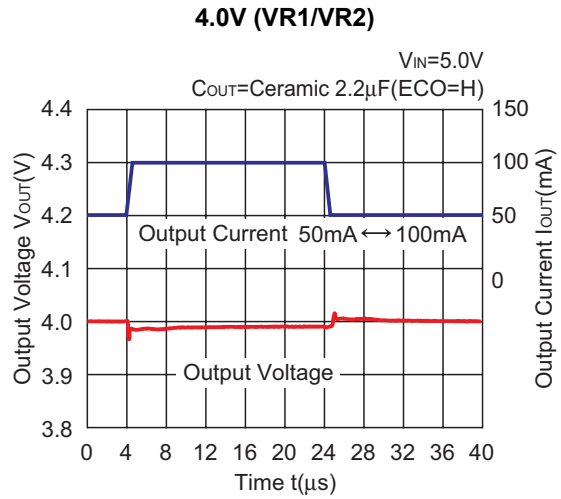
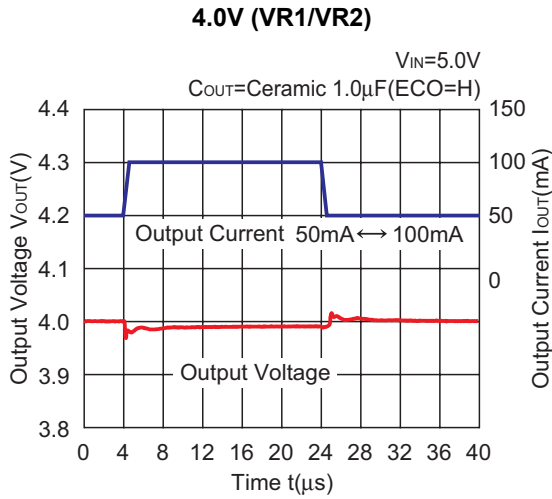

2.8V (VR1/VR2)

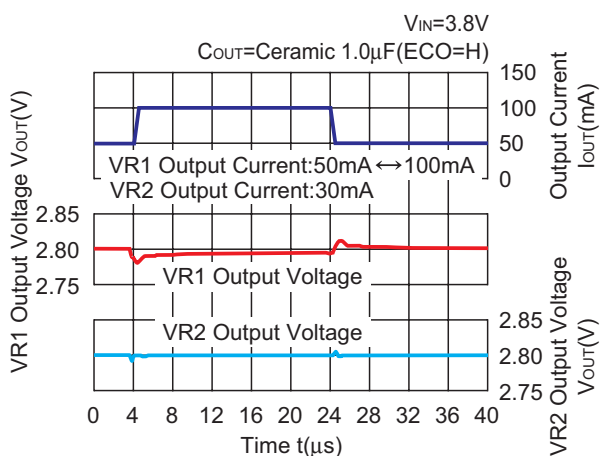

2.8V (VR1/VR2)

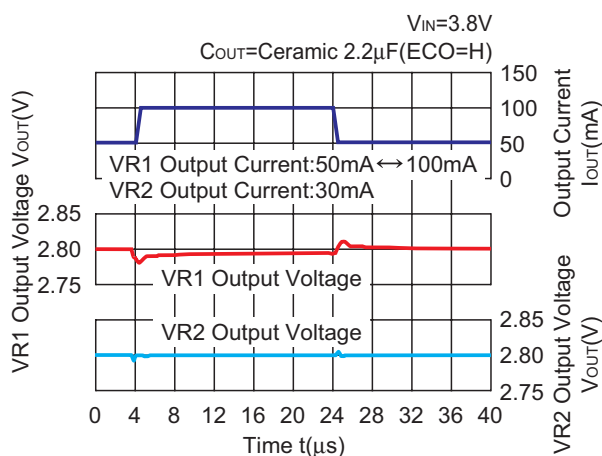

2.8V (VR1/VR2)

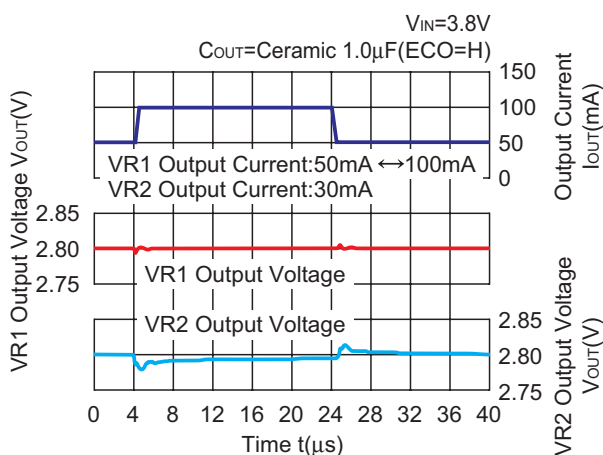

2.8V (VR1/VR2)

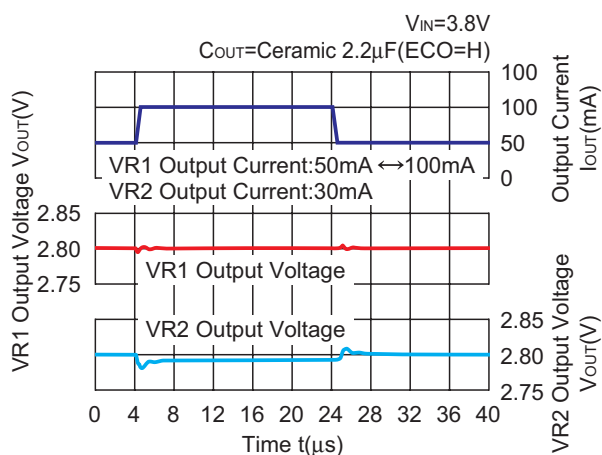

13) Turn on speed by CE pin control ($C_{IN}=1.0\mu F$)

0.8V (VR1/VR2)

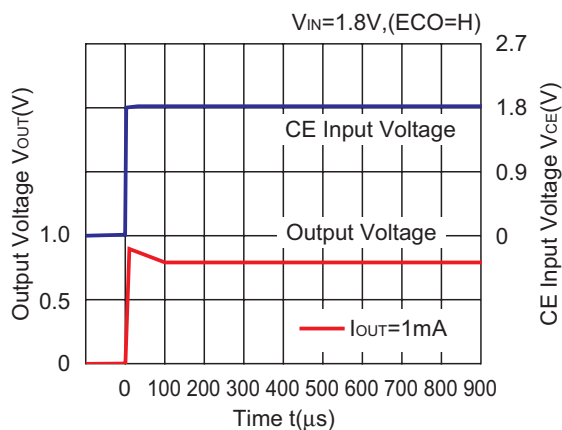

0.8V (VR1/VR2)

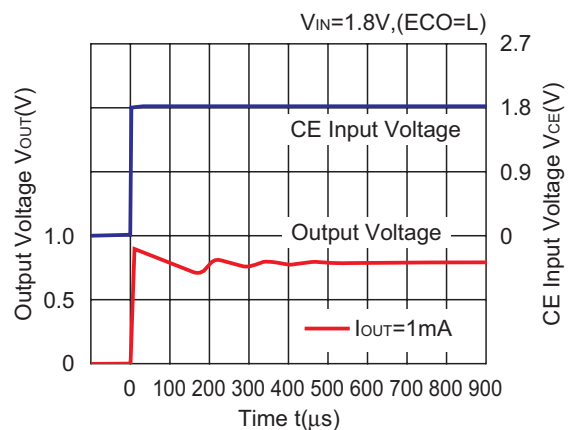

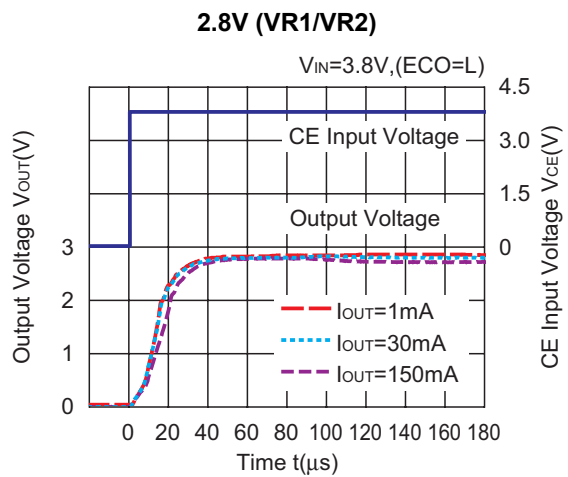
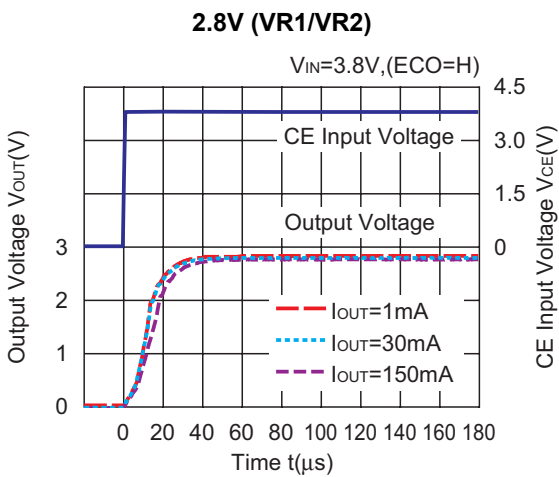
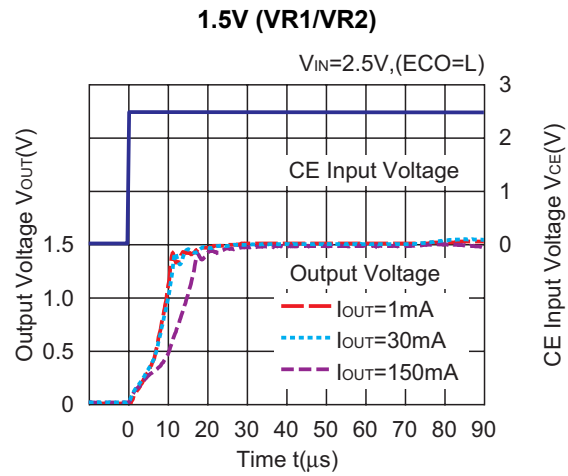
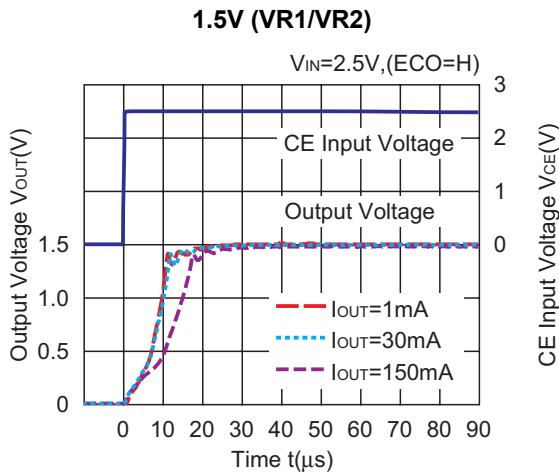
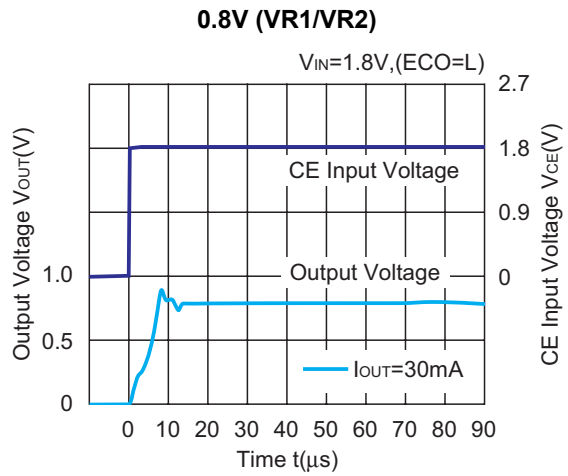
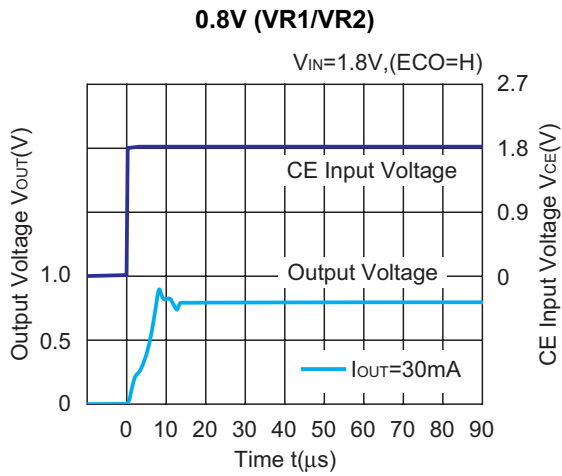

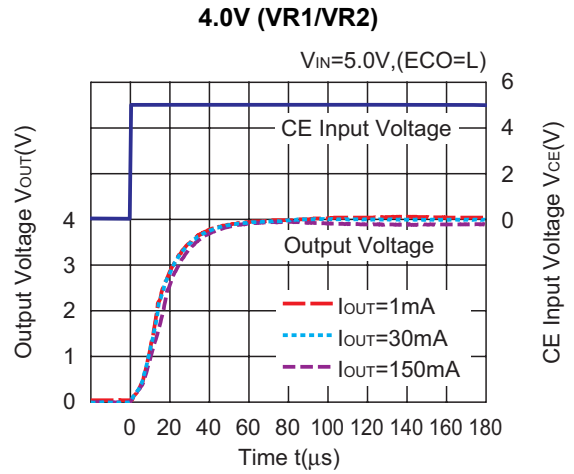
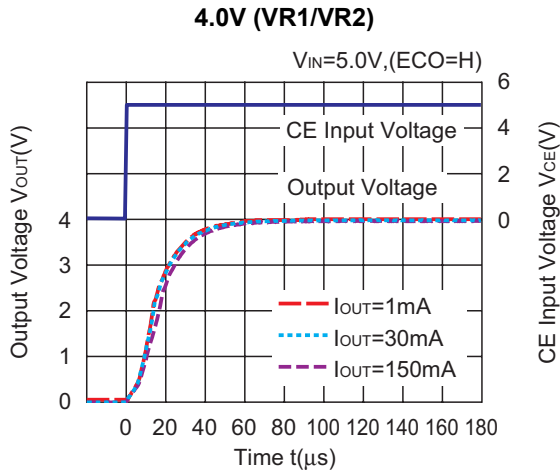

14) Turn off speed by CE pin control ($C_{IN}=1.0\mu F$)

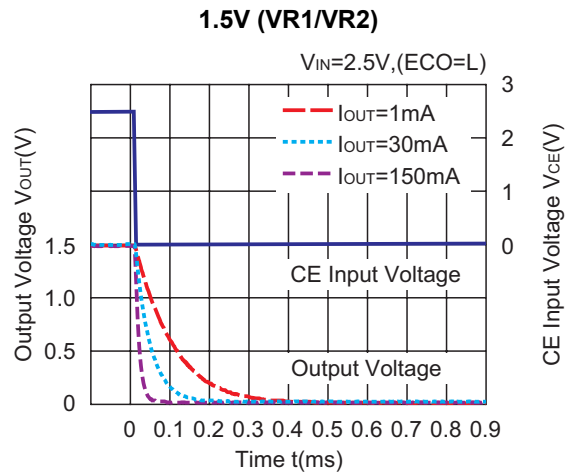
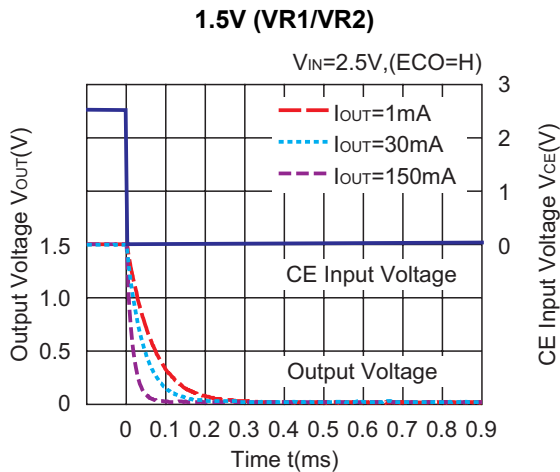
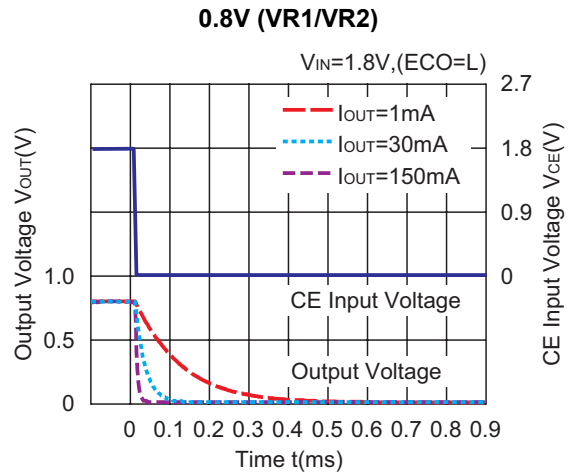
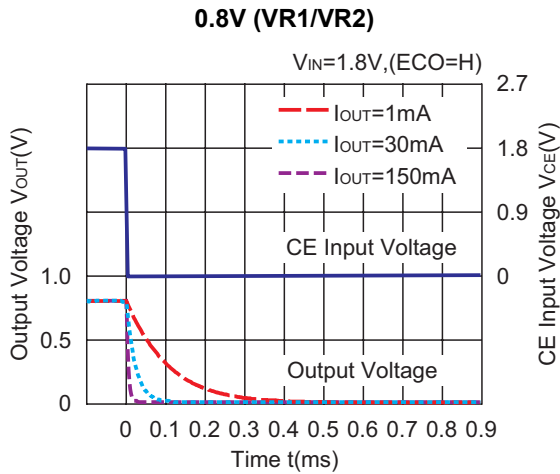

2.8V (VR1/VR2)

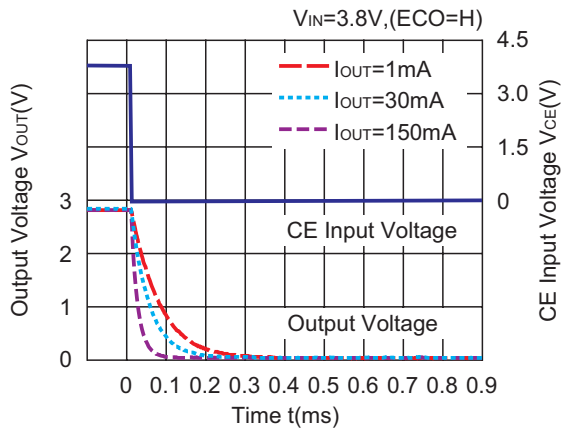

2.8V (VR1/VR2)

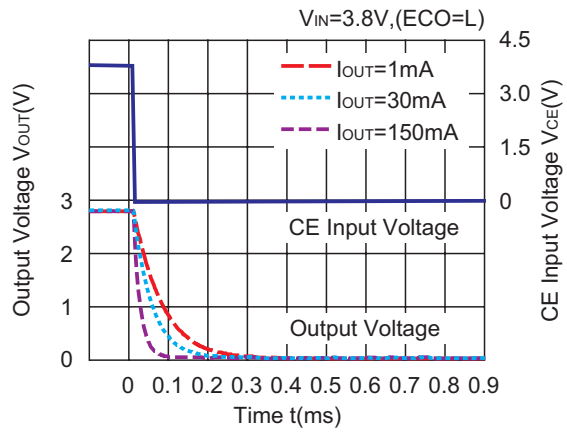

4.0V (VR1/VR2)

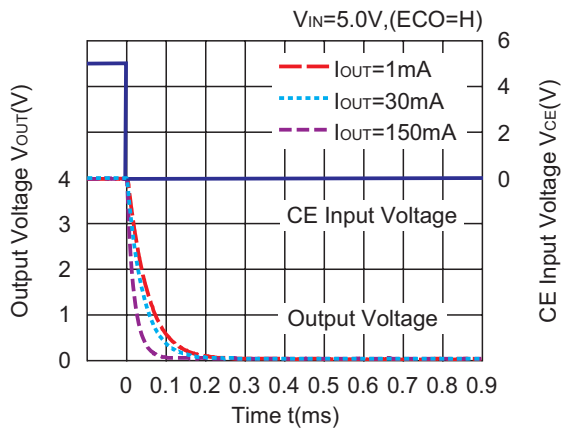

4.0V (VR1/VR2)

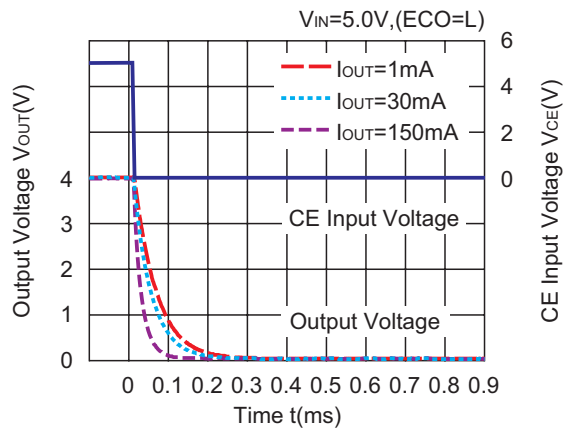

15) Mode Transient Response ($C_{IN}=C_{OUT}=\text{Ceramic } 1.0\mu F$)

0.8V (VR1/VR2)

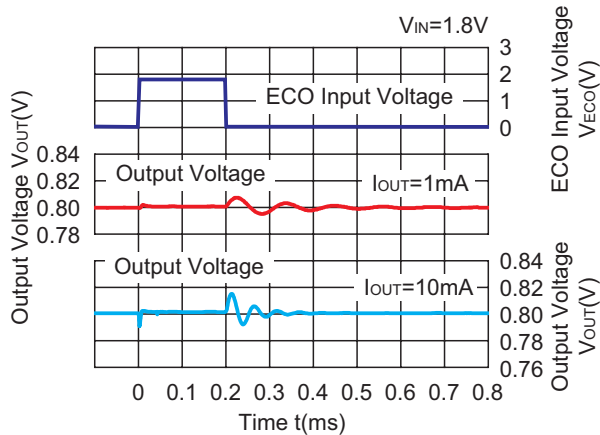

1.5V (VR1/VR2)

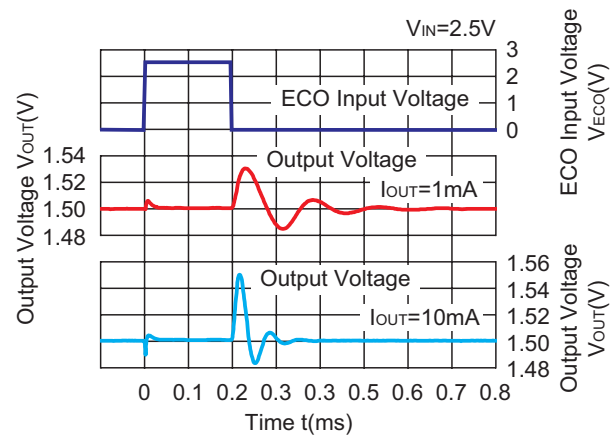

0.8V (VR1/VR2)

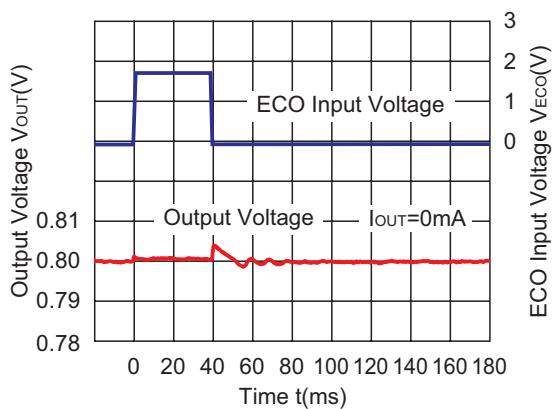

1.5V (VR1/VR2)

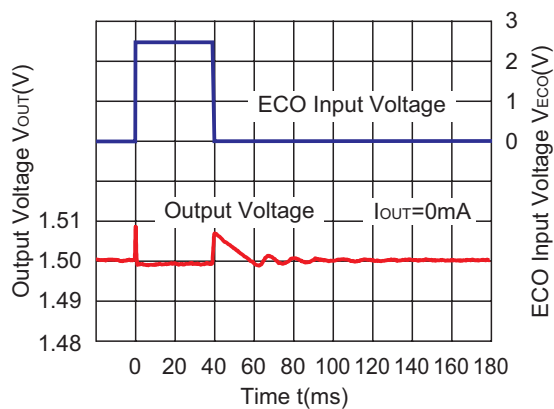

2.8V (VR1/VR2)

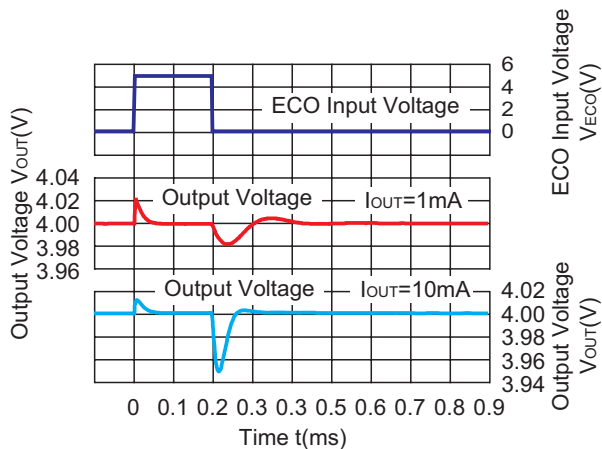

4.0V (VR1/VR2)

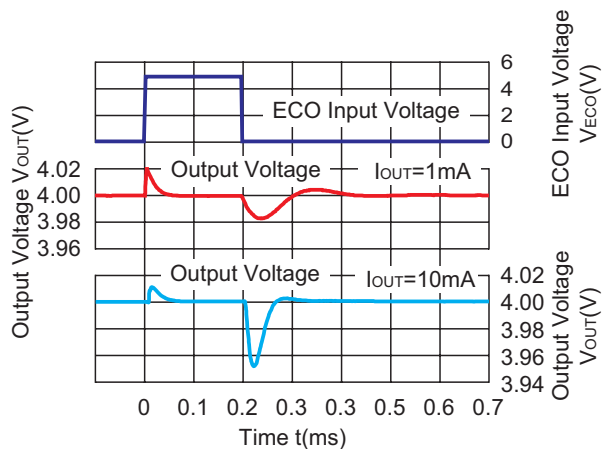

2.8V (VR1/VR2)

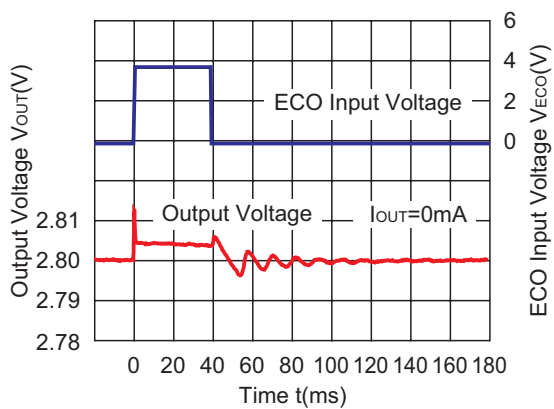

4.0V (VR1/VR2)

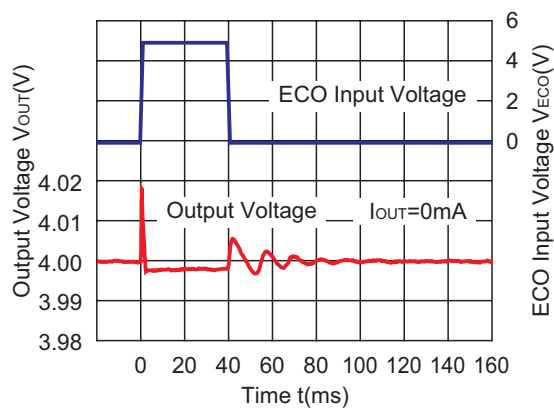

16) ESR vs. Output Current (Hatched area is stable area for the R5328K)

0.8V (VR1/VR2)

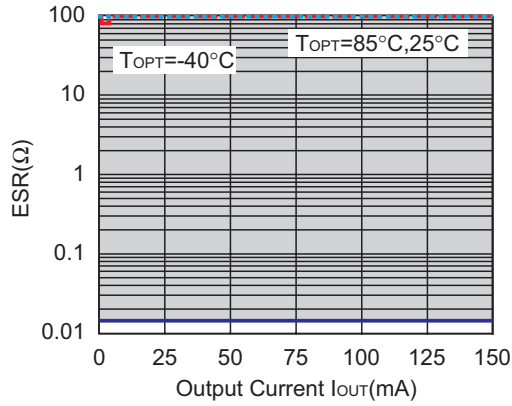

1.5V (VR1/VR2)

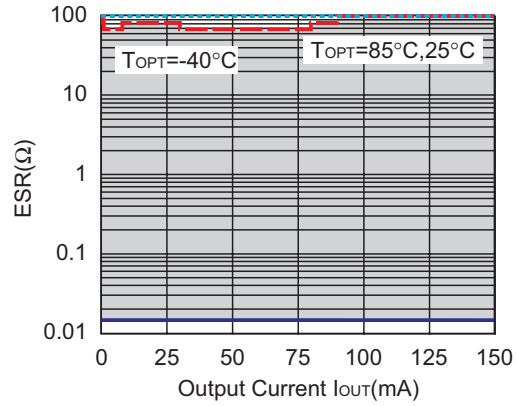

2.8V (VR1/VR2)

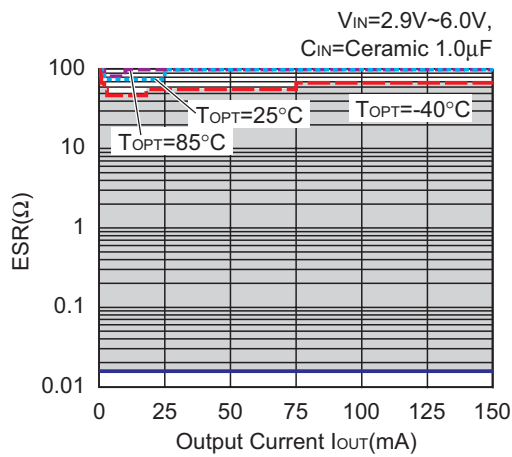

4.0V (VR1/VR2)

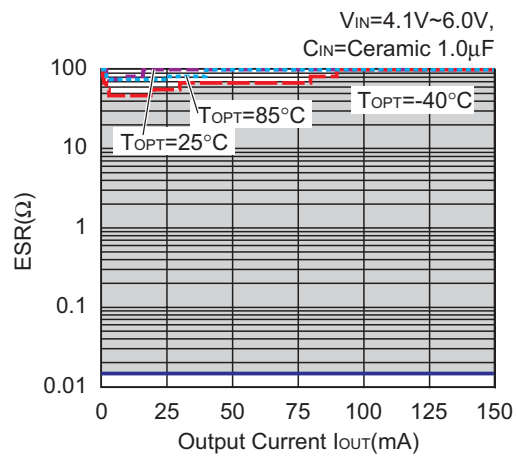

• PLP2020-8

Unit: mm

PACKAGE DIMENSIONS

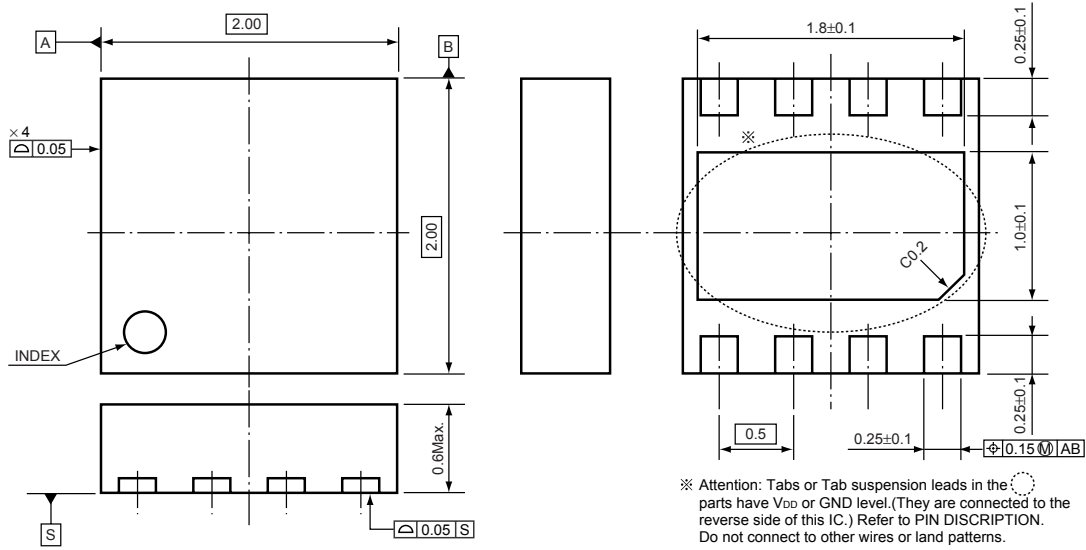

TAPING SPECIFICATION

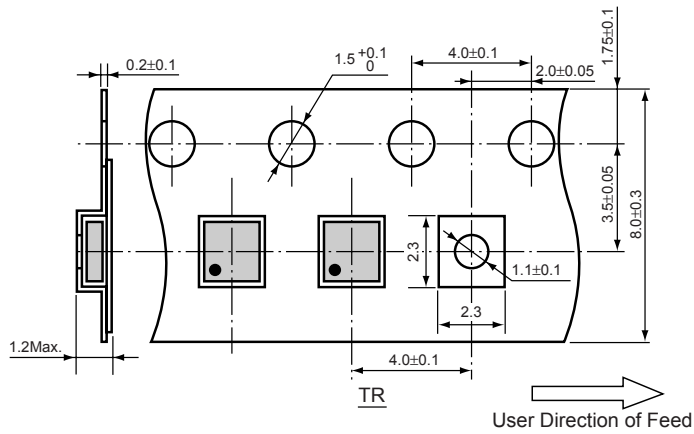

TAPING REEL DIMENSIONS REUSE REEL (EIAJ-RRM-08Bc)

(1reel=5000pcs)

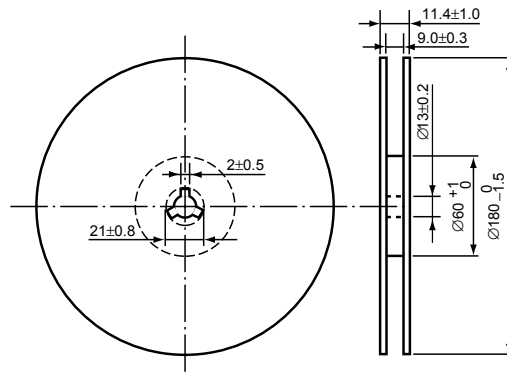

POWER DISSIPATION (PLP2020-8)

This specification is at mounted on board. Power Dissipation (P_D) depends on conditions of mounting on board. This specification is based on the measurement at the condition below:
 (Power Dissipation (PLP2020-8) is substitution of PLP1820-6.)

Measurement Conditions

	Standard Land Pattern
Environment	Mounting on Board (Wind velocity=0m/s)
Board Material	Glass cloth epoxy plactic (Double sided)
Board Dimensions	40mm × 40mm × 1.6mm
Copper Ratio	Top side : Approx. 50% , Back side : Approx. 50%
Through-hole	φ0.54mm × 30pcs

Measurement Result

($T_{opt}=25^{\circ}C, T_{jmax}=125^{\circ}C$)

	Standard Land Pattern
Power Dissipation	880mW
Thermal Resistance	$\theta_{ja}=(125-25^{\circ}C)/0.88W=114^{\circ}C/W$

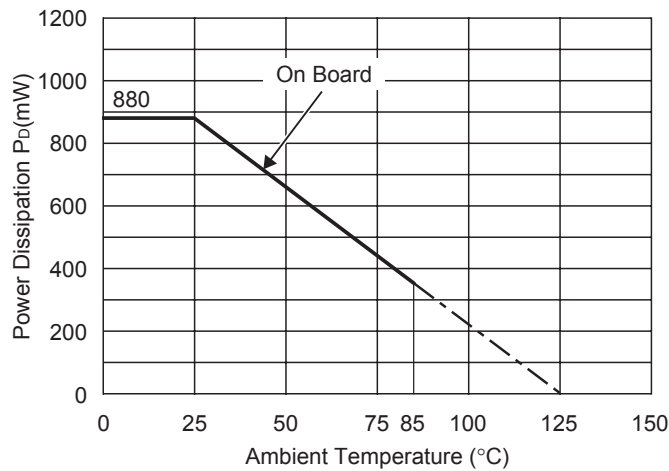

Power Dissipation

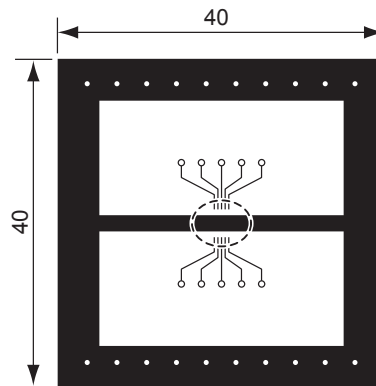

Measurement Board Pattern

○ IC Mount Area Unit : mm

RECOMMENDED LAND PATTERN

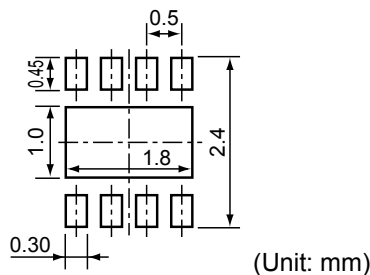

(Unit: mm)

R5328K SERIES MARK SPECIFICATION

- **PLP2020-8**

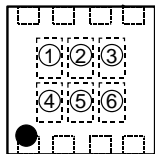

① to ④ : Product Code (refer to Part Number vs. Product Code)

⑤, ⑥ : Lot Number

- **Part Number vs. Product Code**

Part Number	Product Code			
	①	②	③	④
R5328K001A	X	0	0	1
R5328K002A	X	0	0	2
R5328K003A	X	0	0	3
R5328K004A	X	0	0	4
R5328K005A	X	0	0	5
R5328K006A	X	0	0	6

Part Number	Product Code			
	①	②	③	④
R5328K001B	W	0	0	1
R5328K002B	W	0	0	2
R5328K003B	W	0	0	3
R5328K004B	W	0	0	4
R5328K005B	W	0	0	5
R5328K006B	W	0	0	6