

**Description**

The GM71C4400D/DL is the new generation dynamic RAM organized 1,048,576 x 4 bit. GM71C4400D/DL has realized higher density, higher performance and various functions by utilizing advanced CMOS process technology. The GM71C4400D/DL offers Fast Page Mode as a high speed access Mode. Multiplexed address inputs permit the GM71C4400D/DL to be packaged in a standard 300mil 20pin plastic SOJ, and standard 300mil 20pin plastic TSOP II. The package size provides high system bit densities and is compatible with widely available automated testing and insertion equipment. System oriented features include single power supply of 5V ± 10% tolerance, direct interfacing capability with high performance logic families such as Schottky TTL.

**Features**

- 1,048,576 Words x 4 Bit Organization
- Fast Page Mode Capability
- Single Power Supply (5V ± 10%)
- Fast Access Time & Cycle Time

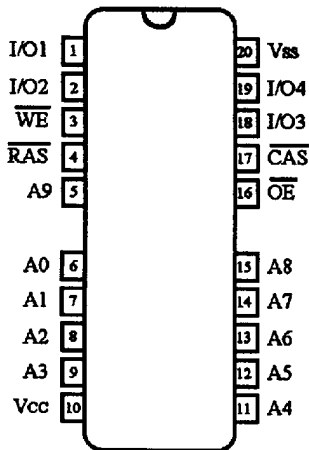
(Unit: ns)

	t <sub>RAC</sub>	t <sub>CAC</sub>	t <sub>RC</sub>	t <sub>PC</sub>
GM71C4400D/DL-60	60	15	110	40
GM71C4400D/DL-70	70	20	130	45
GM71C4400D/DL-80	80	20	150	50

- Low Power  
Active : 440/385/358mW (MAX)  
Standby : 5.5mW (CMOS level : MAX)  
0.55mW (L-series)
- $\overline{\text{RAS}}$  Only Refresh,  $\overline{\text{CAS}}$  before  $\overline{\text{RAS}}$  Refresh, Hidden Refresh Capability
- All inputs and outputs TTL Compatible
- 1024 Refresh Cycles/16ms
- 1024 Refresh Cycles/128ms (L-series)
- Battery Back Up Operation (L-series)

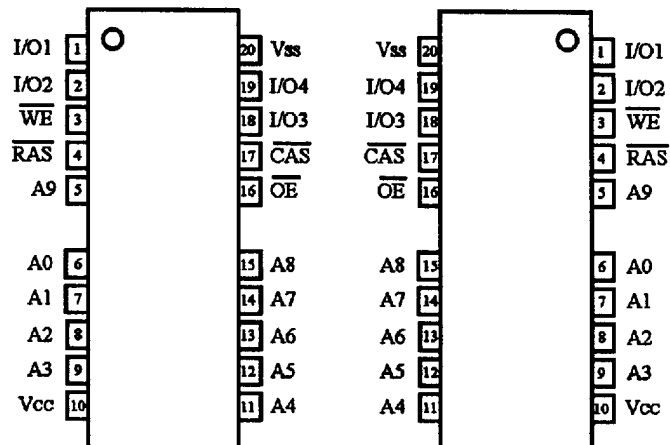
**Pin Configuration**

**20 (26) SOJ**



(Top View)

**20 (26) TSOP II**



(Top View)

**Pin Description**

Pin	Function	Pin	Function
A0-A9	Address Inputs	$\overline{WE}$	Read/Write Enable
A0-A9	Refresh Address Inputs	$\overline{OE}$	Output Enable
I/O1-I/O4	Data Input/Data Output	V <sub>CC</sub>	Power (+5V)
$\overline{RAS}$	Row Address Strobe	V <sub>SS</sub>	Ground
$\overline{CAS}$	Column Address Strobe		

**Ordering Information**

Type No.	Access Time	Package
GM71C4400DJ/DLJ-60 GM71C4400DJ/DLJ-70 GM71C4400DJ/DLJ-80	60 ns 70 ns 80 ns	300 Mil, 20 (26) Pin Plastic SOJ
GM71C4400DT/DLT-60 GM71C4400DT/DLT-70 GM71C4400DT/DLT-80	60 ns 70 ns 80 ns	300 Mil, 20 (26) Pin Plastic TSOP II (Normal Type)
GM71C4400DR/DLR-60 GM71C4400DR/DLR-70 GM71C4400DR/DLR-80	60 ns 70 ns 80 ns	300 Mil, 20 (26) Pin Plastic TSOP II (Reverse Type)

**Absolute Maximum Ratings\***

Symbol	Parameter	Rating	Unit
T <sub>A</sub>	Ambient Temperature under Bias	0 ~ 70	°C
T <sub>STG</sub>	Storage Temperature (Plastic)	-55 ~ 125	°C
V <sub>IN</sub> /V <sub>OUT</sub>	Voltage on any Pin Relative to V <sub>SS</sub>	-1.0 ~ 7.0	V
V <sub>CC</sub>	Voltage on V <sub>CC</sub> Relative to V <sub>SS</sub>	-1.0 ~ 7.0	V
I <sub>OUT</sub>	Short Circuit Output Current	50	mA
P <sub>D</sub>	Power Dissipation	1.0	W

\*Note: Operation at or above Absolute Maximum Ratings can adversely affect device reliability.

**Recommended DC Operating Conditions (T<sub>A</sub> = 0 ~ 70°C)**

Symbol	Parameter	Min	Typ	Max	Unit
V <sub>CC</sub>	Supply Voltage	4.5	5.0	5.5	V
V <sub>IH</sub>	Input High Voltage	2.4	-	6.5	V
V <sub>IL</sub>	Input Low Voltage	-1.0	-	0.8	V

**DC Electrical Characteristics ( $V_{CC} = 5V \pm 10\%$ ,  $T_A = 0 \sim 70^\circ C$ )**

Symbol	Parameter	Min	Max	Unit	Note	
$V_{OH}$	Output Level Output "H" Level Voltage ( $I_{OUT} = -5mA$ )	2.4	$V_{CC}$	V		
$V_{OL}$	Output Level Output "L" Level Voltage ( $I_{OUT} = 4.2mA$ )	0	0.4	V		
$I_{CC1}$	Operating Current Average Power Supply Operating Current ( $\overline{RAS}$ , $\overline{CAS}$ , Address Cycling: $t_{RC} = t_{RC\ min}$ )	60ns	-	80	$\mu A$	1, 2
		70ns	-	70		
		80ns	-	65		
$I_{CC2}$	Standby Current (TTL) Power Supply Standby Current ( $\overline{RAS}$ , $\overline{CAS} = V_{IH}$ , $D_{OUT} = High-Z$ )	-	2	$\mu A$		
$I_{CC3}$	$\overline{RAS}$ -Only Refresh Current Average Power Supply Current $\overline{RAS}$ -Only Refresh Mode ( $\overline{RAS}$ Cycling, $\overline{CAS} = V_{IH}$ , $t_{RC} = t_{RC\ min}$ )	60ns	-	80	$\mu A$	2
		70ns	-	70		
		80ns	-	65		
$I_{CC4}$	Fast Page Mode Current Average Power Supply Current Fast Page Mode ( $\overline{RAS} = V_{IL}$ , $\overline{CAS}$ , Address Cycling: $t_{RC} = t_{RC\ min}$ )	60ns	-	80	$\mu A$	1, 3
		70ns	-	70		
		80ns	-	65		
$I_{CC5}$	Standby Current (CMOS) Power Supply Standby Current ( $\overline{RAS}$ , $\overline{CAS} \geq V_{CC} - 0.2V$ , $D_{OUT} = High-Z$ )	-	1	$\mu A$	5	
		-	100	$\mu A$	4, 5	
$I_{CC6}$	$\overline{CAS}$ -before- $\overline{RAS}$ Refresh Current ( $t_{RC} = t_{RC\ min}$ )	60ns	-	80	$\mu A$	
		70ns	-	70		
		80ns	-	65		
$I_{CC7}$	Battery Back Up Current (Standby with CBR Refresh) ( $t_{RC} = 125\mu s$ , $t_{RAS} \leq 1\mu s$ , $\overline{WE} = V_{IH}$ , $\overline{CAS} = V_{IL}$ , $\overline{OE}$ , Address and $D_{IN} = V_{IH}$ or $V_{IL}$ , $D_{OUT} = High-Z$ )	-	300	$\mu A$	4, 5	
$I_{CC8}$	Standby Current $\overline{RAS} = V_{IH}$ $\overline{CAS} = V_{IL}$ $D_{OUT} = Enable$	-	5	$\mu A$	1	
$I_{(i)}$	Input Leakage Current Any Input ( $0V \leq V_{IN} \leq 7V$ )	-10	10	$\mu A$		
$I_{(o)}$	Output Leakage Current ( $D_{OUT}$ is Disabled, $0V \leq V_{OUT} \leq 7V$ )	-10	10	$\mu A$		

Note: 1.  $I_{CC}$  depends on output load condition when the device is selected.  $I_{CC(max)}$  is specified at the output open condition.

2. Address can be changed once or less while  $\overline{RAS} = V_{IL}$ .
3. Address can be changed once or less while  $\overline{CAS} = V_{IH}$ .
4. L Series.
5.  $V_{CC} - 0.2V \leq V_{IH} \leq 6.5V$ ,  $0V \leq V_{IL} \leq 0.2V$ .

**Capacitance ( $V_{CC} = 5V \pm 10\%$ ,  $T_A = 25^\circ C$ )**

Symbol	Parameter	Min	Max	Unit	Note
$C_{I1}$	Input Capacitance (Address)	-	5	pF	1
$C_{I2}$	Input Capacitance (Clocks)	-	7	pF	1
$C_{I/O}$	Data Input,Output Capacitance (Data-In,Out)	-	7	pF	1, 2

Note: 1. Capacitance measured with Boonton Meter or effective capacitance measuring method.  
 2.  $\overline{CAS} = V_{IH}$  to disable Door.

**AC Characteristics ( $V_{CC} = 5V \pm 10\%$ ,  $T_A = 0 \sim 70^\circ C$ , Notes 1, 14, 15, 16)**
**Test Conditions**

Input rise and fall times: 5ns

 Output load : 2 TTL gate +  $C_L$  (100pF)

Input, output timing reference levels: 0.8V, 2.4V

(Including scope and jig)

**Read, Write, Read-Modify-Write and Refresh Cycles (Common Parameters)**

Symbol	Parameter	GM71C4400 DDL-60		GM71C4400 DDL-70		GM71C4400 DDL-80		Unit	Note
		Min	Max	Min	Max	Min	Max		
$t_{RC}$	Random Read or Write Cycle Time	110	-	130	-	150	-	ns	
$t_{RP}$	$\overline{RAS}$ Precharge Time	40	-	50	-	60	-	ns	
$t_{RAS}$	$\overline{RAS}$ Pulse Width	60	10,000	70	10,000	80	10,000	ns	
$t_{CAS}$	$\overline{CAS}$ Pulse Width	15	10,000	20	10,000	20	10,000	ns	
$t_{ASR}$	Row Address Set-up Time	0	-	0	-	0	-	ns	
$t_{RAH}$	Row Address Hold Time	10	-	10	-	10	-	ns	
$t_{ASC}$	Column Address Set-up Time	0	-	0	-	0	-	ns	
$t_{CAH}$	Column Address Hold Time	15	-	15	-	15	-	ns	
$t_{RCD}$	$\overline{RAS}$ to $\overline{CAS}$ Delay Time	20	45	20	50	20	60	ns	8
$t_{RAD}$	$\overline{RAS}$ to Column Address Delay Time	15	30	15	35	15	40	ns	9
$t_{RSH}$	$\overline{RAS}$ Hold Time	15	-	20	-	20	-	ns	
$t_{CSH}$	$\overline{CAS}$ Hold Time	60	-	70	-	80	-	ns	
$t_{CRP}$	$\overline{CAS}$ to $\overline{RAS}$ Precharge Time	10	-	10	-	10	-	ns	
$t_{ODD}$	$\overline{OE}$ to $D_{IN}$ Delay Time	15	-	20	-	20	-	ns	
$t_{DZO}$	$\overline{OE}$ Delay Time from $D_{IN}$	0	-	0	-	0	-	ns	
$t_{DZC}$	$\overline{CAS}$ Set-up Time from $D_{IN}$	0	-	0	-	0	-	ns	
$t_T$	Transition Time (Rise and Fall)	3	50	3	50	3	50	ns	7
$t_{REF}$	Refresh Period (1024 Cycles)	-	16	-	16	-	16	ms	
	Refresh Period (1024 Cycles)	-	128	-	128	-	128	ms	L-Series

**Read Cycle**

Symbol	Parameter	GM71C4400 DDL-60		GM71C4400 DDL-70		GM71C4400 DDL-80		Unit	Note
		Min	Max	Min	Max	Min	Max		
$t_{RAC}$	Access Time from $\overline{RAS}$	-	60	-	70	-	80	ns	2,3,17
$t_{CAC}$	Access Time from $\overline{CAS}$	-	15	-	20	-	20	ns	3, 4, 13, 17
$t_{AA}$	Access Time from Address	-	30	-	35	-	40	ns	3, 5, 13, 17
$t_{OAC}$	Access Time from $\overline{OE}$	-	15	-	20	-	20	ns	3,17
$t_{RCS}$	Read Command Setup Time	0	-	0	-	0	-	ns	
$t_{RCH}$	Read Command Hold Time to $\overline{CAS}$	0	-	0	-	0	-	ns	18
$t_{RRH}$	Read Command Hold Time to $\overline{RAS}$	0	-	0	-	0	-	ns	18
$t_{RAL}$	Column Address to $\overline{RAS}$ Lead Time	30	-	35	-	40	-	ns	
$t_{OFF1}$	Output Buffer Turn-off Time	0	15	0	20	0	20	ns	6
$t_{OFF2}$	Output Buffer Turn-off Time from $\overline{OE}$	0	15	0	20	0	20	ns	6
$t_{CDD}$	$\overline{CAS}$ to $D_{IN}$ Delay Time	15	-	20	-	20	-	ns	
$t_{OEP}$	$\overline{OE}$ Pulse width	15	-	20	-	20	-	ns	

**Write Cycle**

Symbol	Parameter	GM71C4400 DDL-60		GM71C4400 DDL-70		GM71C4400 DDL-80		Unit	Note
		Min	Max	Min	Max	Min	Max		
$t_{WCS}$	Write Command Setup Time	0	-	0	-	0	-	ns	10
$t_{WCH}$	Write Command Hold Time	15	-	15	-	15	-	ns	
$t_{WP}$	Write Command Pulse Width	10	-	10	-	10	-	ns	
$t_{RWL}$	Write Command to $\overline{RAS}$ Lead Time	15	-	20	-	20	-	ns	
$t_{CWL}$	Write Command to $\overline{CAS}$ Lead Time	15	-	20	-	20	-	ns	
$t_{DS}$	Data-in Setup Time	0	-	0	-	0	-	ns	11
$t_{DH}$	Data-in Hold Time	15	-	15	-	15	-	ns	11

**Read-Modify-Write Cycle**

Symbol	Parameter	GM71C4400 DDL-60		GM71C4400 DDL-70		GM71C4400 DDL-80		Unit	Note
		Min	Max	Min	Max	Min	Max		
t <sub>RWC</sub>	Read-Modify-Write Cycle Time	150	-	180	-	200	-	ns	
t <sub>RWD</sub>	$\overline{\text{RAS}}$ to $\overline{\text{WE}}$ Delay Time	80	-	95	-	105	-	ns	10
t <sub>CWD</sub>	$\overline{\text{CAS}}$ to $\overline{\text{WE}}$ Delay Time	35	-	45	-	45	-	ns	10
t <sub>AWD</sub>	Column Address to $\overline{\text{WE}}$ Delay Time	50	-	60	-	65	-	ns	10
t <sub>OBH</sub>	$\overline{\text{OE}}$ Hold Time from $\overline{\text{WE}}$	15	-	20	-	20	-	ns	

**Refresh Cycle**

Symbol	Parameter	GM71C4400 DDL-60		GM71C4400 DDL-70		GM71C4400 DDL-80		Unit	Note
		Min	Max	Min	Max	Min	Max		
t <sub>CSR</sub>	$\overline{\text{CAS}}$ Set-up Time ( $\overline{\text{CAS}}$ -before- $\overline{\text{RAS}}$ Refresh Cycle)	10	-	10	-	10	-	ns	
t <sub>CHR</sub>	$\overline{\text{CAS}}$ Hold Time ( $\overline{\text{CAS}}$ -before- $\overline{\text{RAS}}$ Refresh Cycle)	10	-	10	-	10	-	ns	
t <sub>RPC</sub>	$\overline{\text{RAS}}$ Precharge to $\overline{\text{CAS}}$ Hold Time	10	-	10	-	10	-	ns	
t <sub>CPN</sub>	$\overline{\text{CAS}}$ Precharge Time in Normal Mode	10	-	10	-	10	-	ns	

**Fast Page Mode Cycle**

Symbol	Parameter	GM71C4400 DDL-60		GM71C4400 DDL-70		GM71C4400 DDL-80		Unit	Note
		Min	Max	Min	Max	Min	Max		
t <sub>PC</sub>	Fast Page Mode Cycle Time	40	-	45	-	50	-	ns	
t <sub>CP</sub>	Fast Page Mode $\overline{\text{CAS}}$ Precharge Time	10	-	10	-	10	-	ns	
t <sub>RASP</sub>	Fast Page Mode $\overline{\text{RAS}}$ Pulse Width	-	100,000	-	100,000	-	100,000	ns	12
t <sub>ACP</sub>	Access Time from $\overline{\text{CAS}}$ Precharge	-	35	-	40	-	45	ns	3,13,17
t <sub>RHCP</sub>	$\overline{\text{RAS}}$ Hold Time from $\overline{\text{CAS}}$ Precharge	35	-	40	-	45	-	ns	
t <sub>CPW</sub>	Fast Page Mode Read-Modify-Write Cycle $\overline{\text{CAS}}$ Precharge to $\overline{\text{WE}}$ Delay Time	55	-	65	-	70	-	ns	
t <sub>PCM</sub>	Fast Page Mode Read-Modify-Write Cycle Time	80	-	95	-	100	-	ns	10

**Test Mode Cycle**

Symbol	Parameter	GM71C4400 D/DL-60		GM71C4400 D/DL-70		GM71C4400 D/DL-80		Unit	Note
		Min	Max	Min	Max	Min	Max		
t <sub>ws</sub>	Test Mode $\overline{WE}$ Setup Time	0	-	0	-	0	-	ns	
t <sub>wh</sub>	Test Mode $\overline{WE}$ Hold Time	10	-	10	-	10	-	ns	

**Counter Test Cycle**

Symbol	Parameter	GM71C4400 D/DL-60		GM71C4400 D/DL-70		GM71C4400 D/DL-80		Unit	Note
		Min	Max	Min	Max	Min	Max		
t <sub>cpr</sub>	$\overline{CAS}$ Precharge Time in Counter Test Cycle	40	-	40	-	40	-	ns	

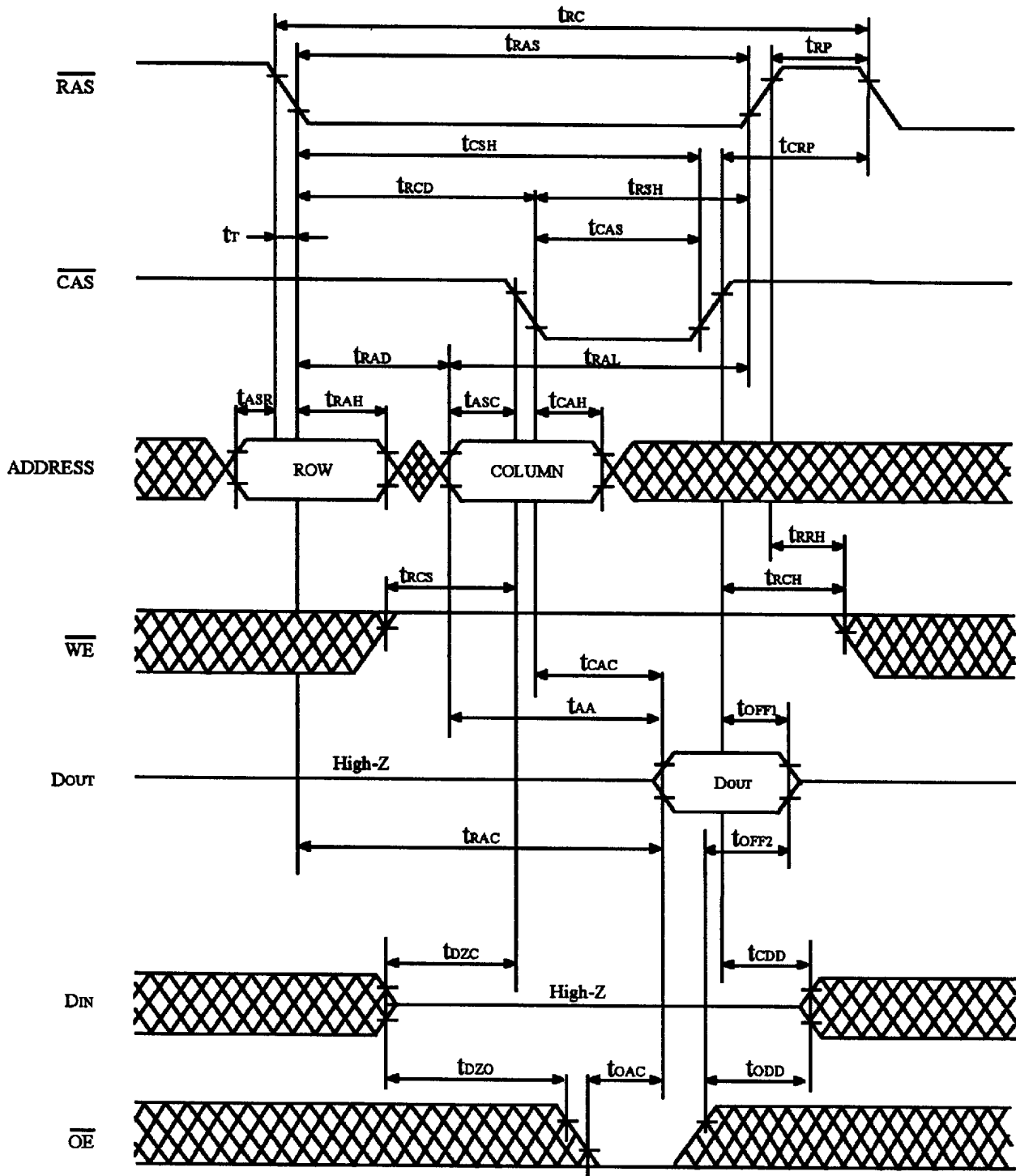
**Notes:**

1. AC Measurements assume  $t_r = 5ns$ .
2. Assumes that  $tr_{CD} \leq tr_{CD(max)}$  and  $tr_{AD} \leq tr_{AD(max)}$ . If  $tr_{CD}$  or  $tr_{AD}$  is greater than the maximum recommended value shown in this table,  $tr_{AC}$  exceeds the value shown.
3. Measured with a load circuit equivalent to 2TTL loads and 100pF.
4. Assumes that  $tr_{CD} \geq tr_{CD(max)}$  and  $tr_{AD} \leq tr_{AD(max)}$ .
5. Assumes that  $tr_{CD} \leq tr_{CD(max)}$  and  $tr_{AD} \geq tr_{AD(max)}$ .
6.  $t_{off(max)}$  defines the time at which the output achieves the open circuit condition and is not referenced to output voltage levels.
7.  $V_{IH(min)}$  and  $V_{IL(max)}$  are reference levels for measuring timing of input signals. Also, transition times are measured between  $V_{IH}$  and  $V_{IL}$ .
8. Operation with the  $tr_{CD(max)}$  limit insures that  $tr_{AC(max)}$  can be met,  $tr_{CD(max)}$  is specified as a reference point only; if  $tr_{CD}$  is greater than the specified  $tr_{CD(max)}$  limit, then access time is controlled exclusively by  $t_{CAC}$ .
9. Operation with the  $tr_{AD(max)}$  limit insures that  $tr_{AC(max)}$  can be met,  $tr_{AD(max)}$  is specified as a reference point only; if  $tr_{AD}$  is greater than the specified  $tr_{AD(max)}$  limit, then access time is controlled exclusively by  $t_{AA}$ .

10.  $t_{wCS}$ ,  $t_{rWD}$ ,  $t_{cWD}$ ,  $t_{cPW}$  and  $t_{aWD}$  are not restrictive operating parameters. They are included in the data sheet as electrical characteristics only; if  $t_{wCS} \geq t_{wCS}(\min)$ , the cycle is an early write cycle and the data out pin will remain open circuit (high impedance) throughout the entire cycle; if  $t_{rWD} \geq t_{rWD}(\min)$ ,  $t_{cWD} \geq t_{cWD}(\min)$ ,  $t_{aWD} \geq t_{aWD}(\min)$  and  $t_{cPW} \geq t_{cPW}(\min)$ , the cycle is a read-modify-write and the data output will contain data read from the selected cell; if neither of the above sets of conditions is satisfied, the condition of the data out (at access time) is indeterminate.
11. These parameters are referenced to  $\overline{CAS}$  leading edge in early write cycles and to  $\overline{WE}$  leading edge in delayed write or a read modify write cycle.
12.  $t_{RASP}$  defines  $\overline{RAS}$  pulse width in fast page mode cycles.
13. Access time is determined by the longer of  $t_{AA}$  or  $t_{CAC}$  or  $t_{ACP}$ .
14. An initial pause of  $100\mu s$  is required after power up followed by a minimum of eight initialization cycles ( $\overline{RAS}$  only refresh cycle or  $\overline{CAS}$  before  $\overline{RAS}$  refresh cycle). If the internal refresh counter is used, a minimum of eight  $\overline{CAS}$  before  $\overline{RAS}$  refresh cycles is required.
15. In delayed write or read-modify-write cycles,  $\overline{OE}$  must disable output buffer prior to applying data to the device.
16. Test mode operation specified in this data sheet is 2-bit test function controlled by control address bits - - - CA0. This test mode operation can be performed by  $\overline{WE}$ -and- $\overline{CAS}$ -before- $\overline{RAS}$  (WCBR) refresh cycle. Refresh during test mode operation will be performed by normal read cycles or by WCBR refresh cycles. When the state of two test bits accord each other, the condition of the output data is high level. When the state of two test bits do not accord, the condition of the output data is low level. In order to end this test mode operation, perform a  $\overline{RAS}$  only refresh cycle or a  $\overline{CAS}$ -before- $\overline{RAS}$  refresh cycle.
17. In a test mode read cycle, the value of  $t_{rAC}$ ,  $t_{AA}$ ,  $t_{CAC}$ ,  $t_{OAC}$  and  $t_{ACP}$  is delayed for 2 ns to 5 ns for the specified value. These parameters should be specified in test mode cycles by adding the above value to the specified value in this data sheet.

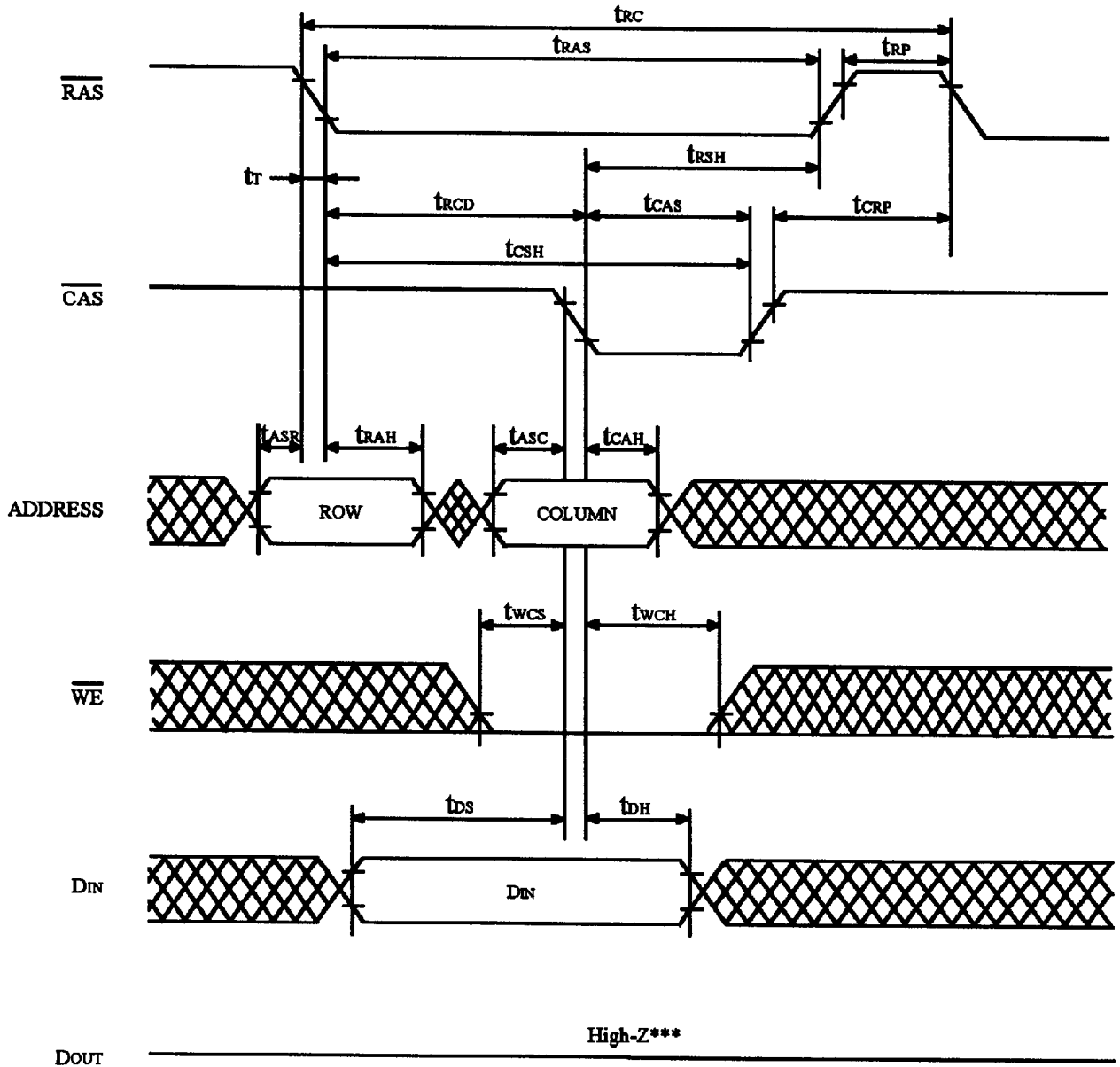


**Timing Waveforms**



\*  : Don't care

**FIGURE 1. READ CYCLE**




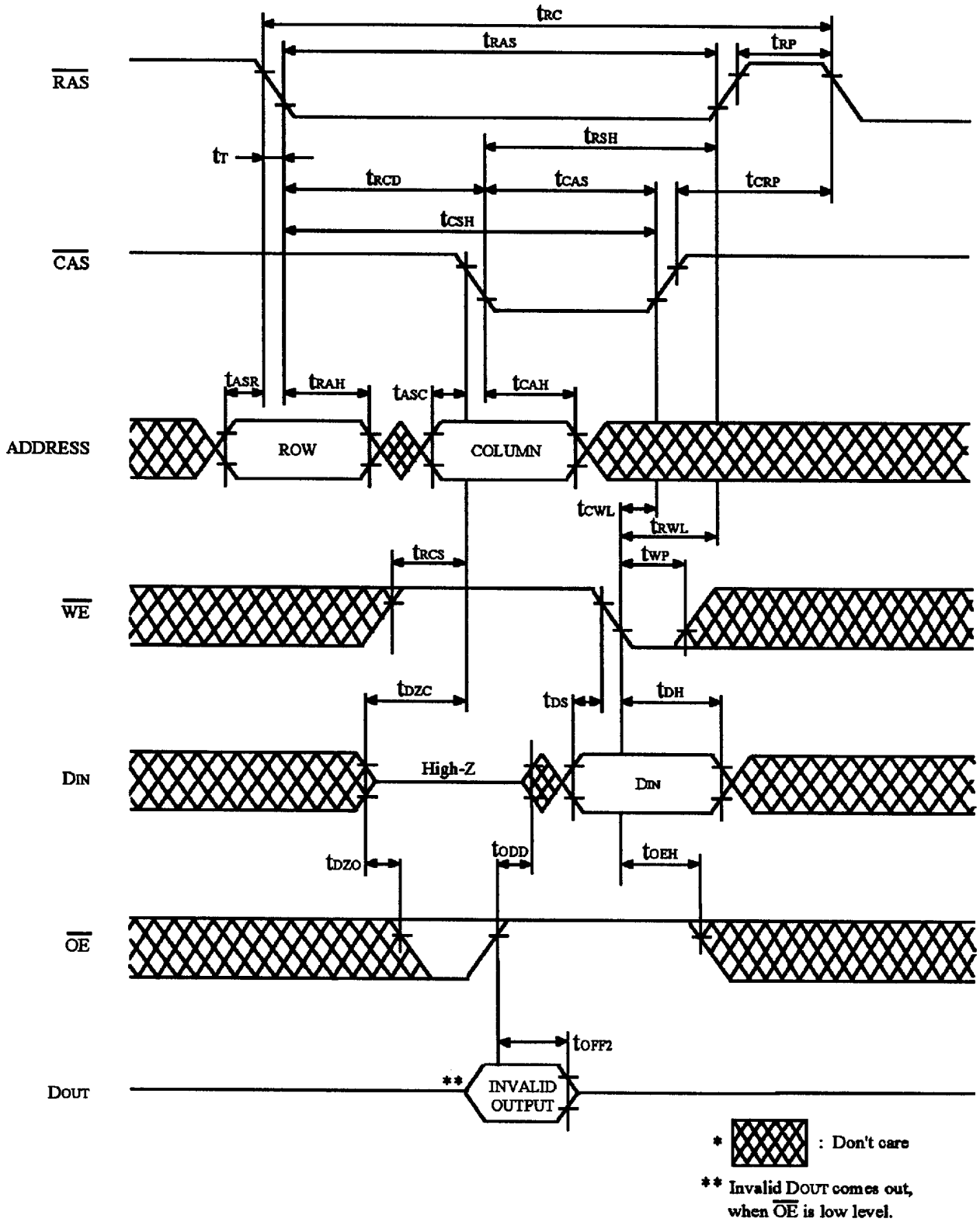
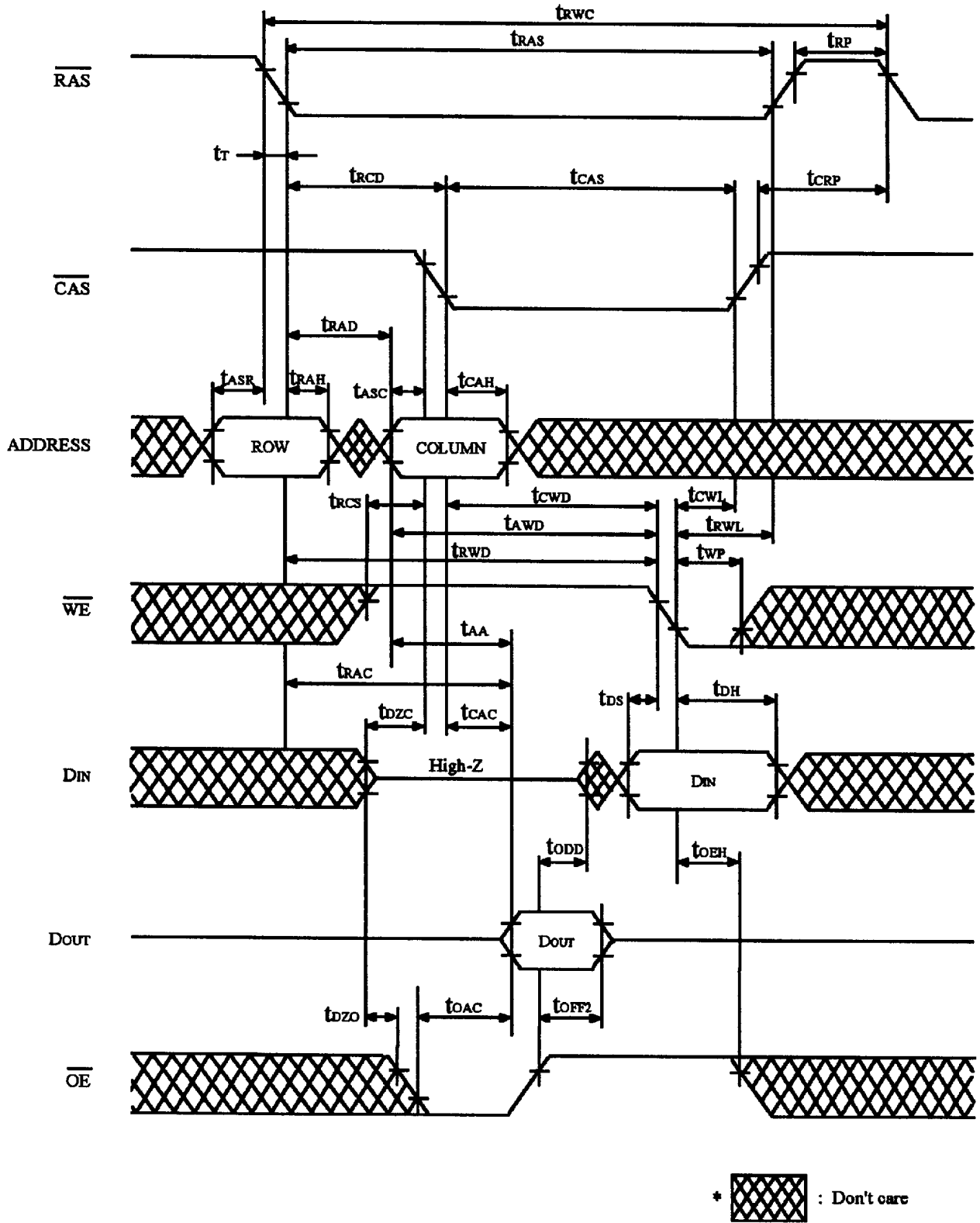
- \*  : Don't care
- \*\*  $\overline{OE}$  : Don't care
- \*\*\*  $t_{wcs} \geq t_{wcs}(\text{min})$

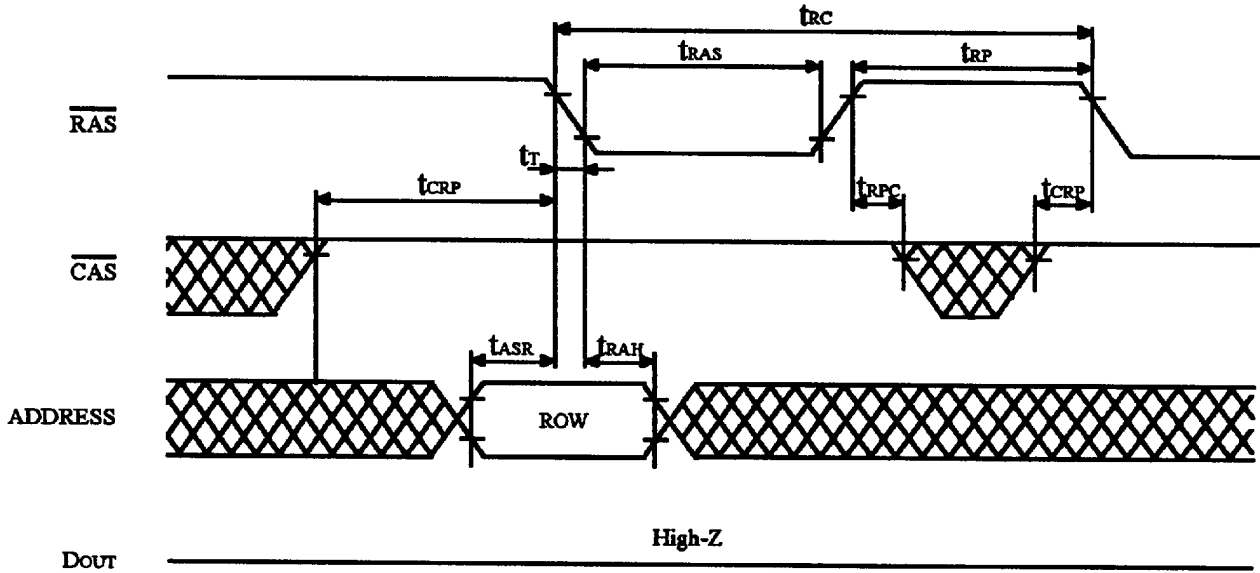
FIGURE 2. EARLY WRITE CYCLE



**FIGURE 3. DELAYED WRITE CYCLE**

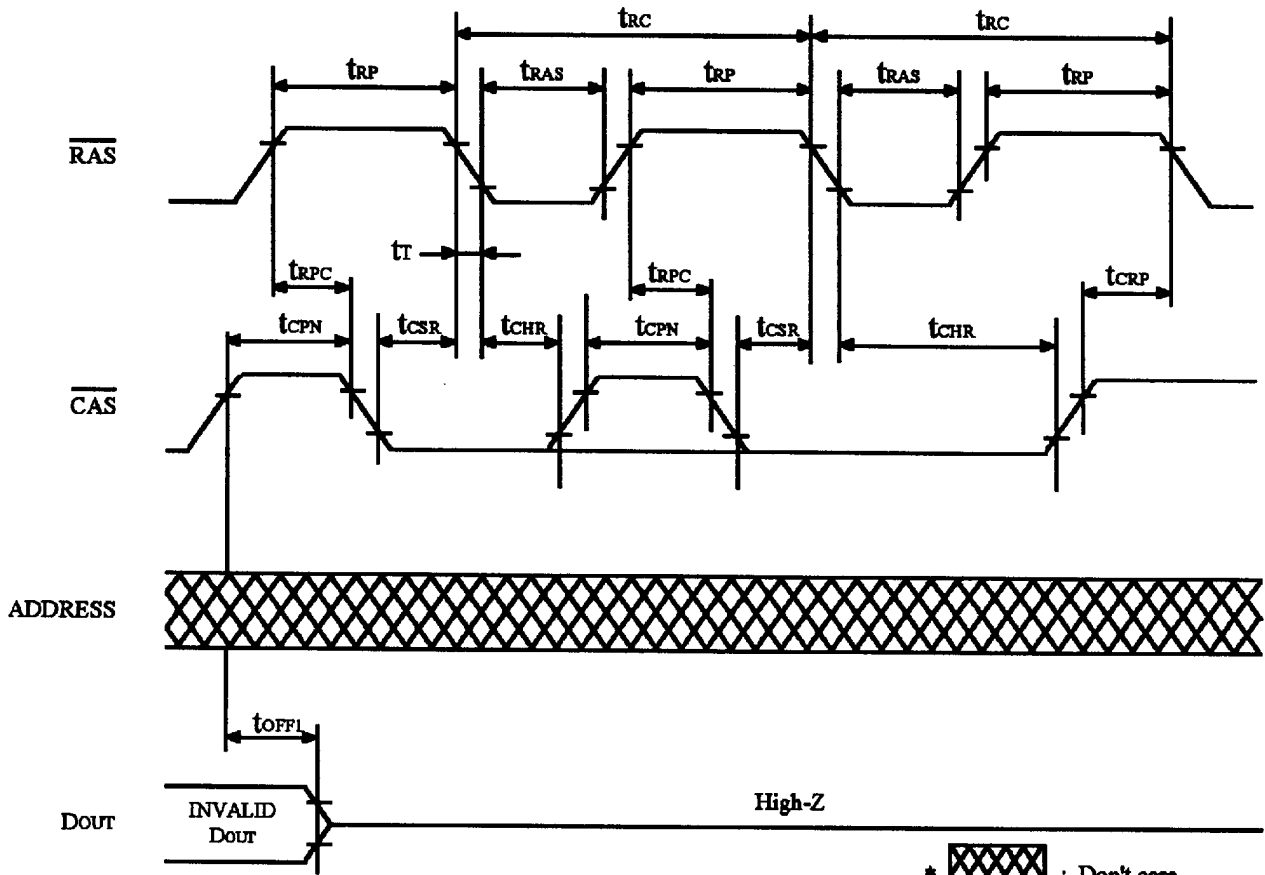


**FIGURE 4. READ MODIFY WRITE CYCLE**



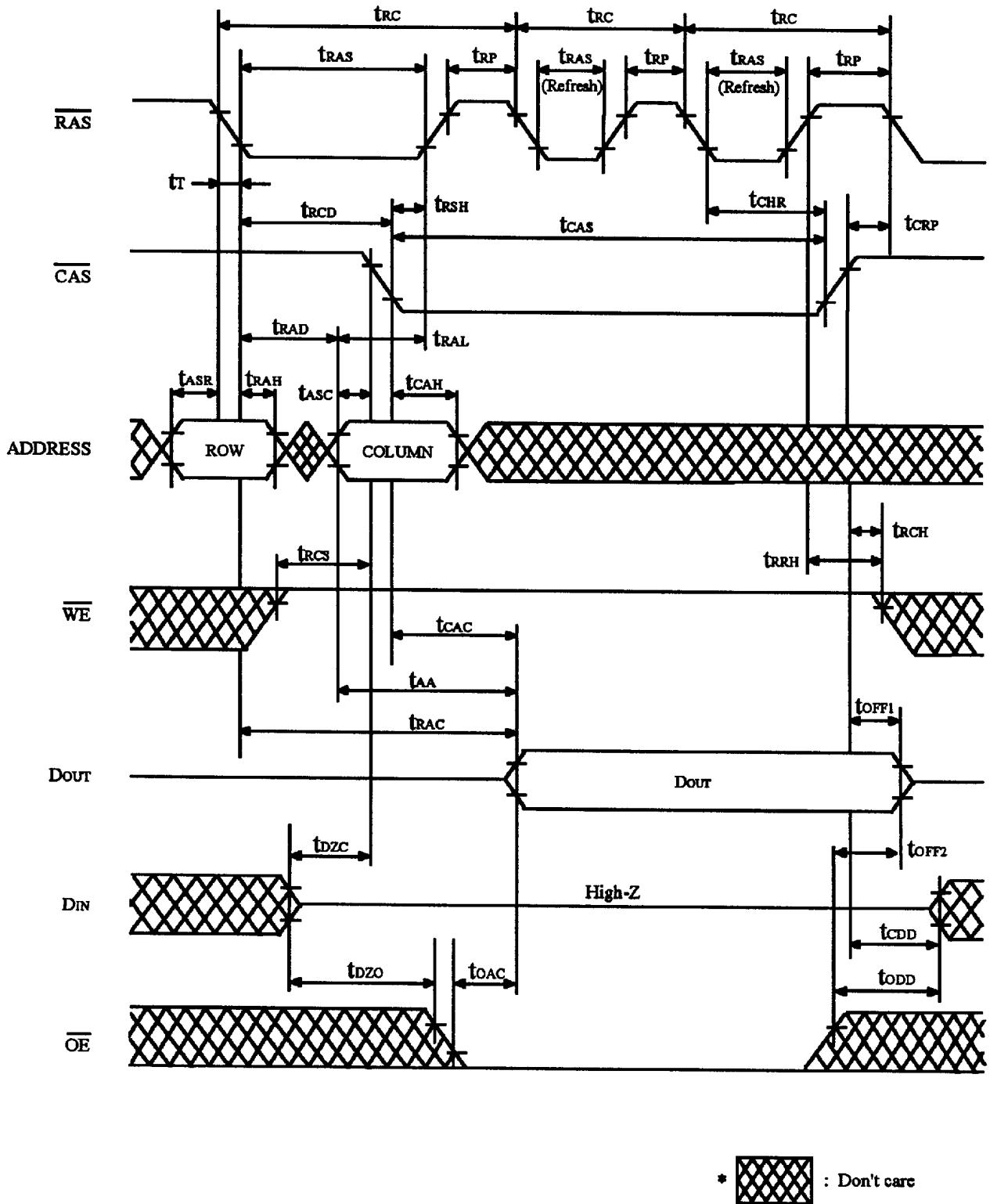
**FIGURE 5. RAS ONLY REFRESH CYCLE**

\*  $\overline{OE}, \overline{WE}$  : Don't care  
 \*\* Refresh address : A0~A9

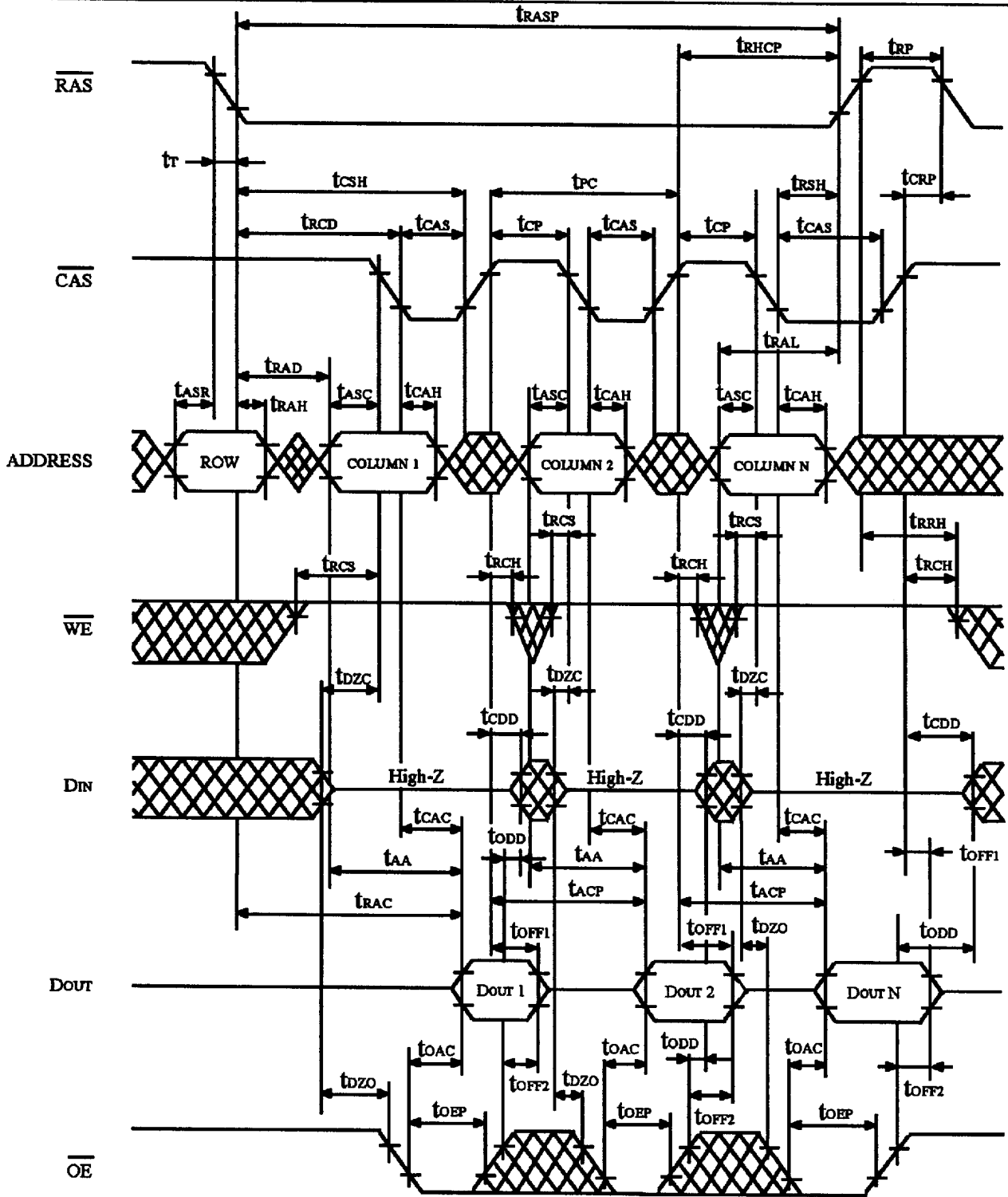


**FIGURE 6. CAS BEFORE RAS REFRESH CYCLE**

\* [Cross-hatched] : Don't care  
 \*\*  $\overline{WE}$  :  $V_{IH}$

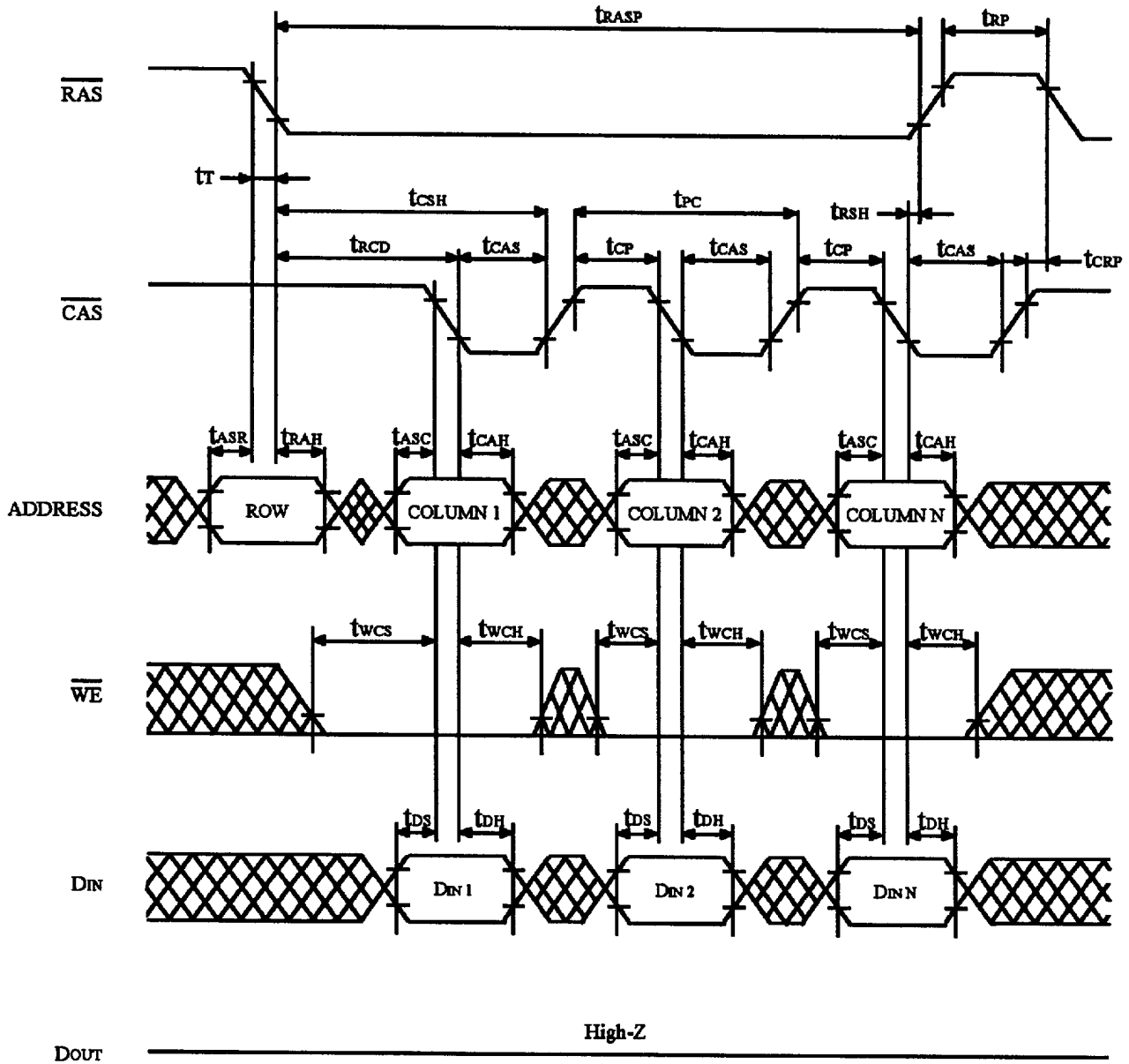



**FIGURE 7. HIDDEN REFRESH CYCLE**



\*  : Don't care

**FIGURE 8. FAST PAGE MODE READ CYCLE**

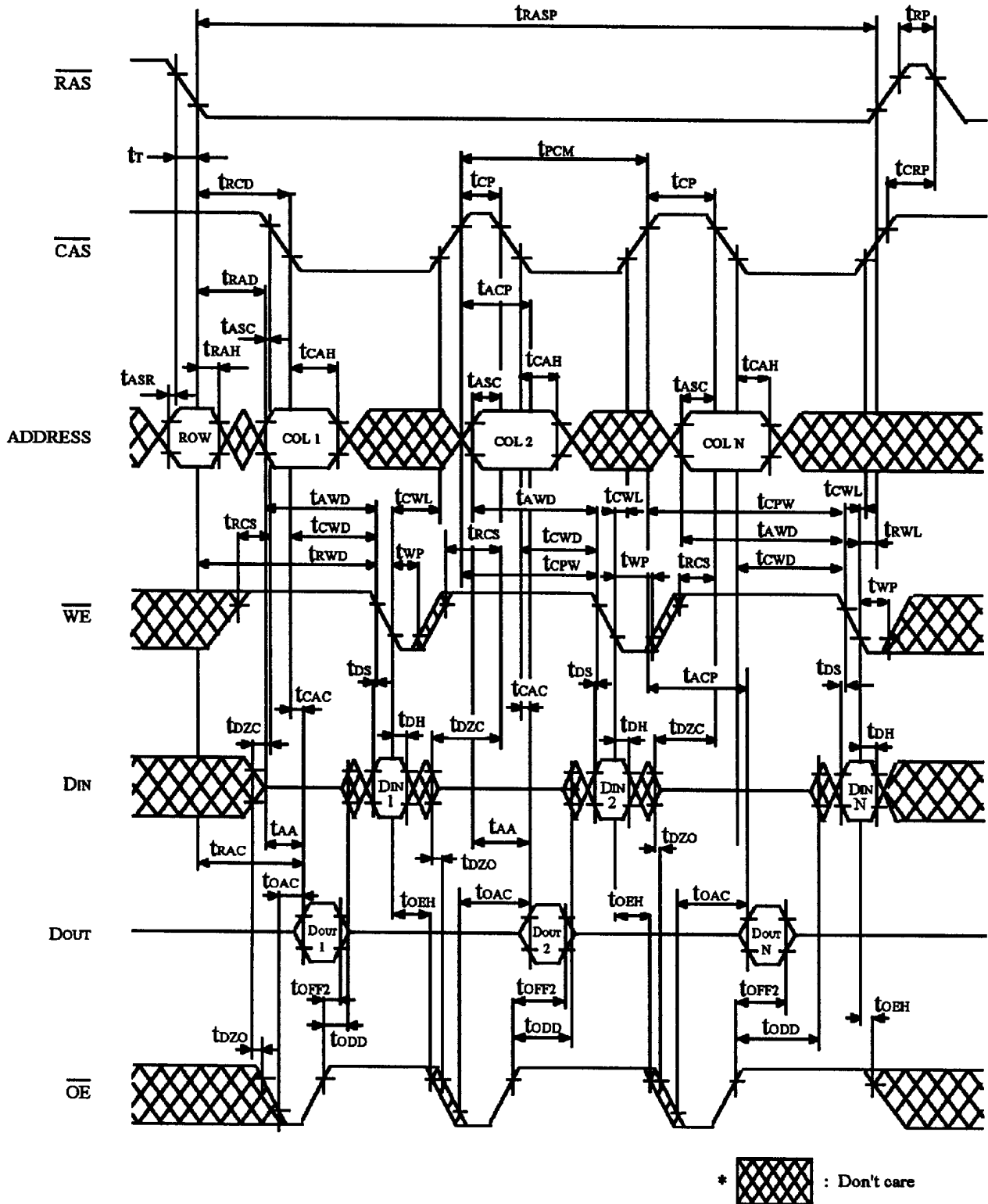


\*  $\overline{OE}$  : Don't care  
 \*\*  : Don't care

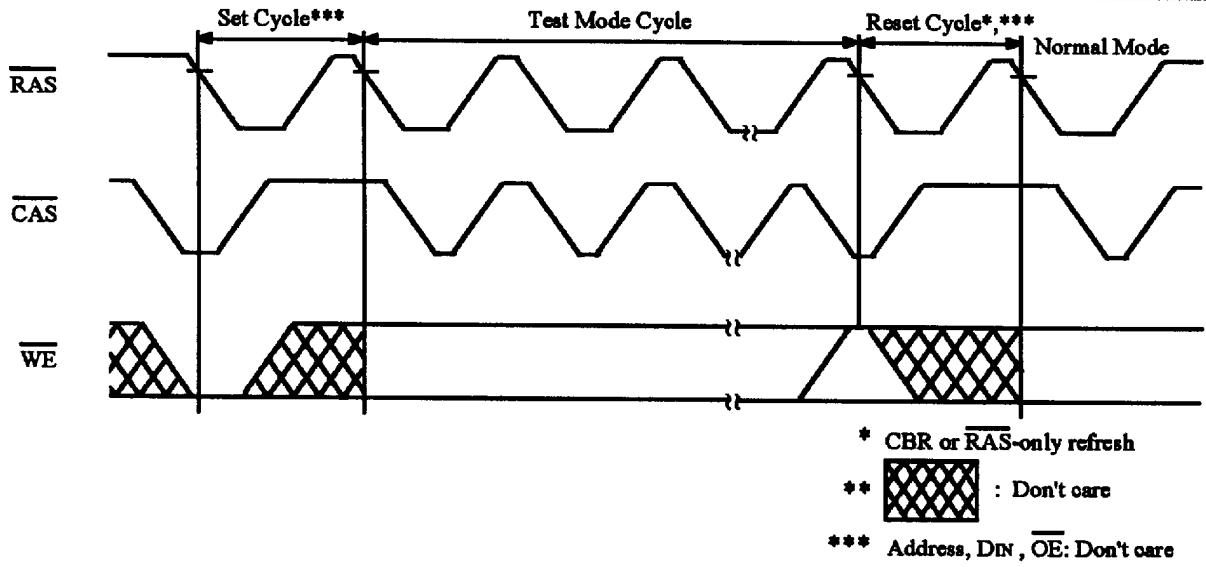
**FIGURE 9. FAST PAGE MODE EARLY WRITE CYCLE**



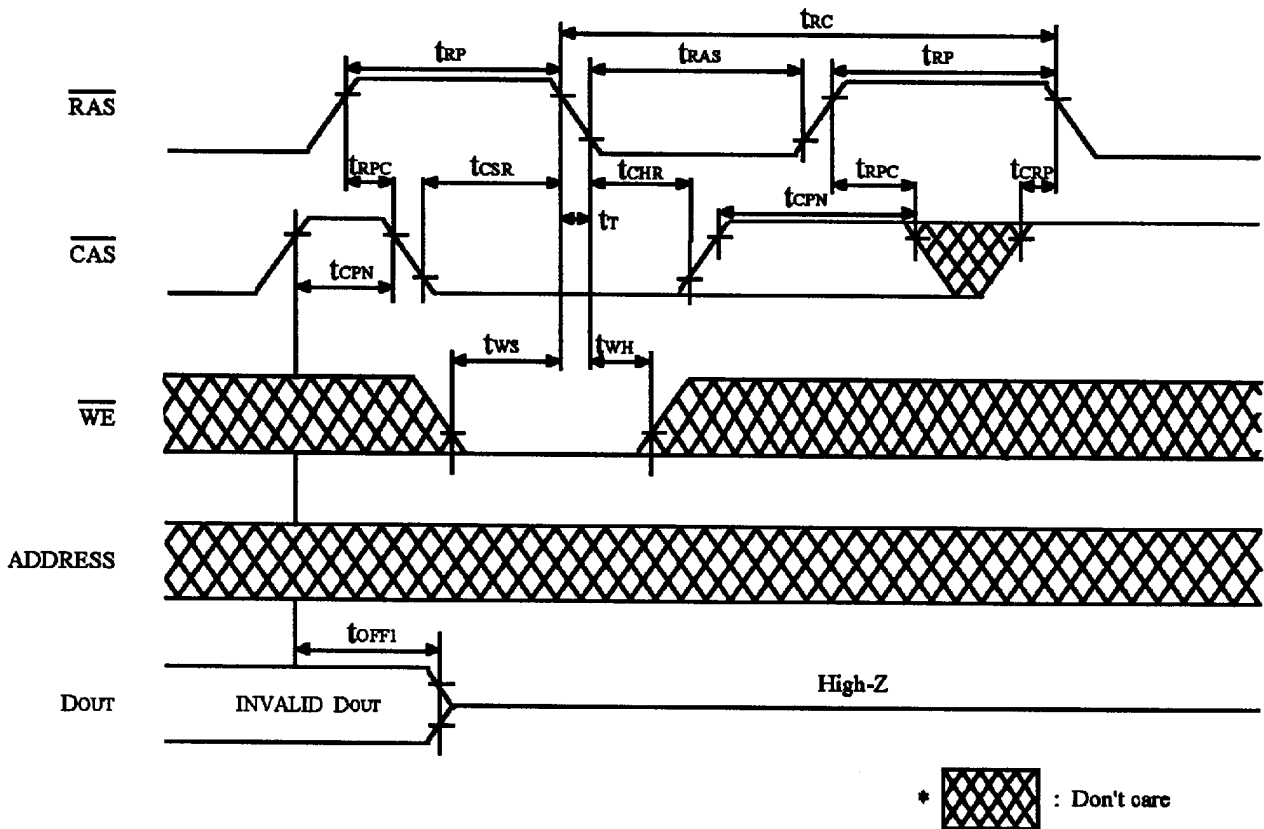




**FIGURE 11. FAST PAGE MODE READ MODIFY WRITE CYCLE**

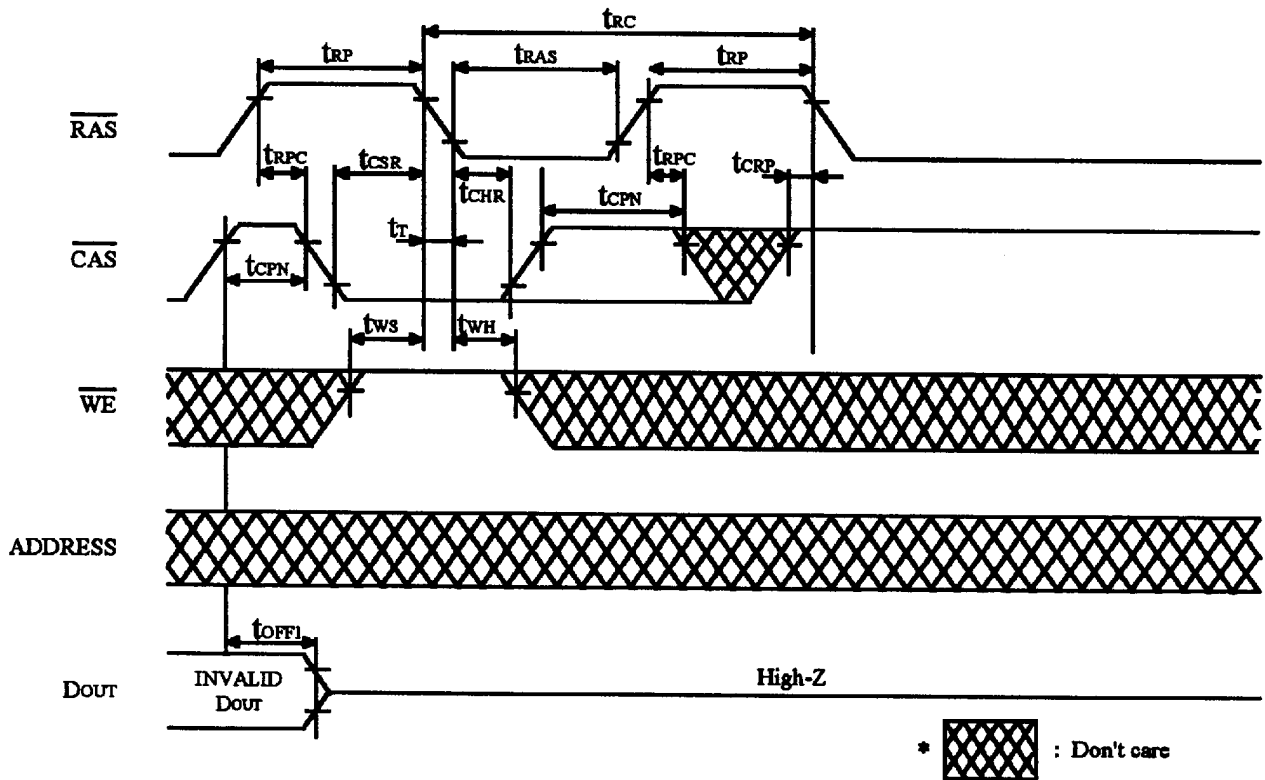


**FIGURE 12. TEST MODE CYCLE**

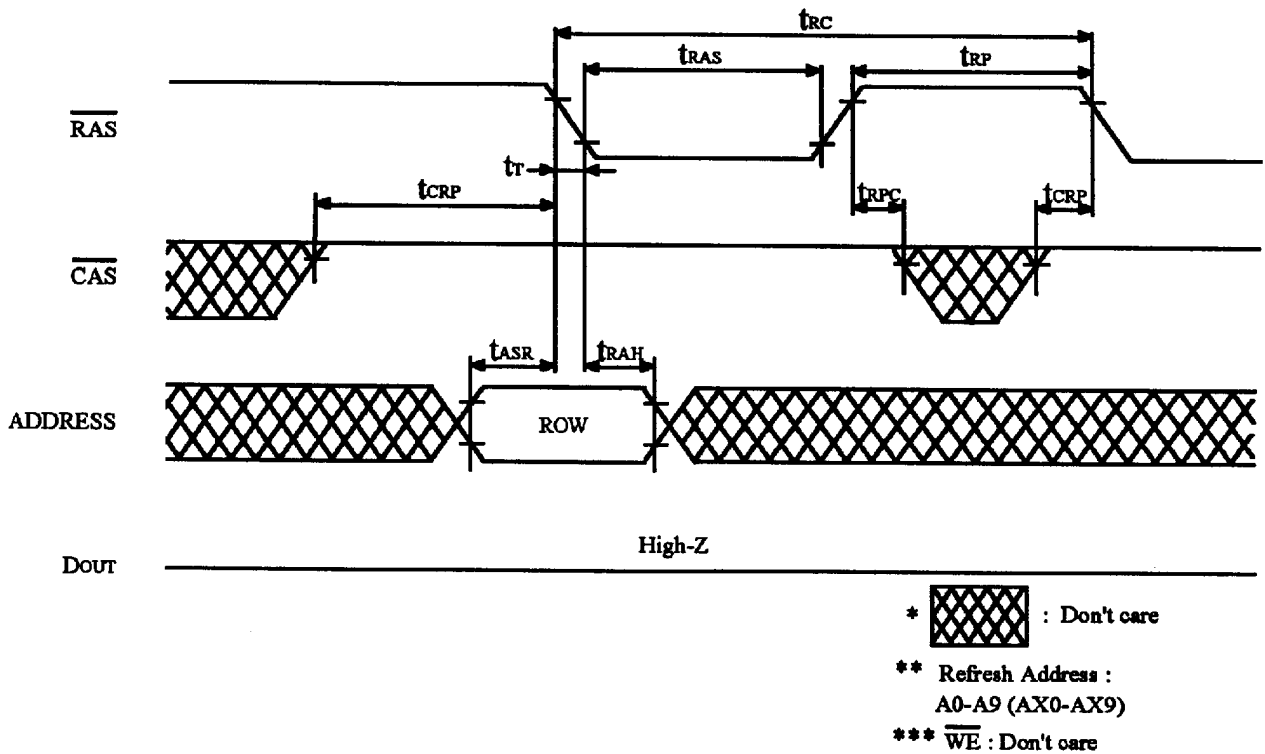


**FIGURE 13. TEST MODE SET CYCLE**

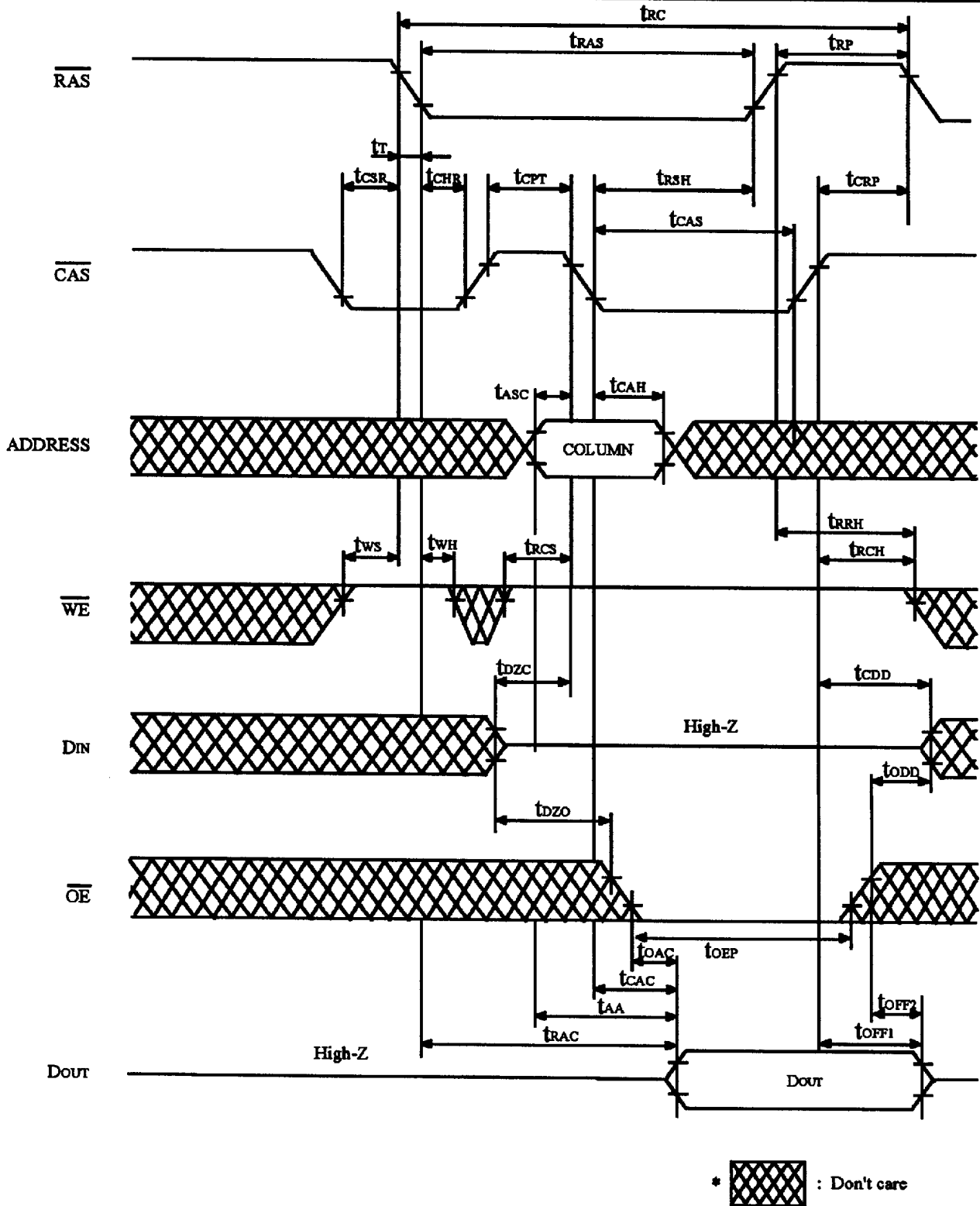
**Test Mode Reset Cycle**



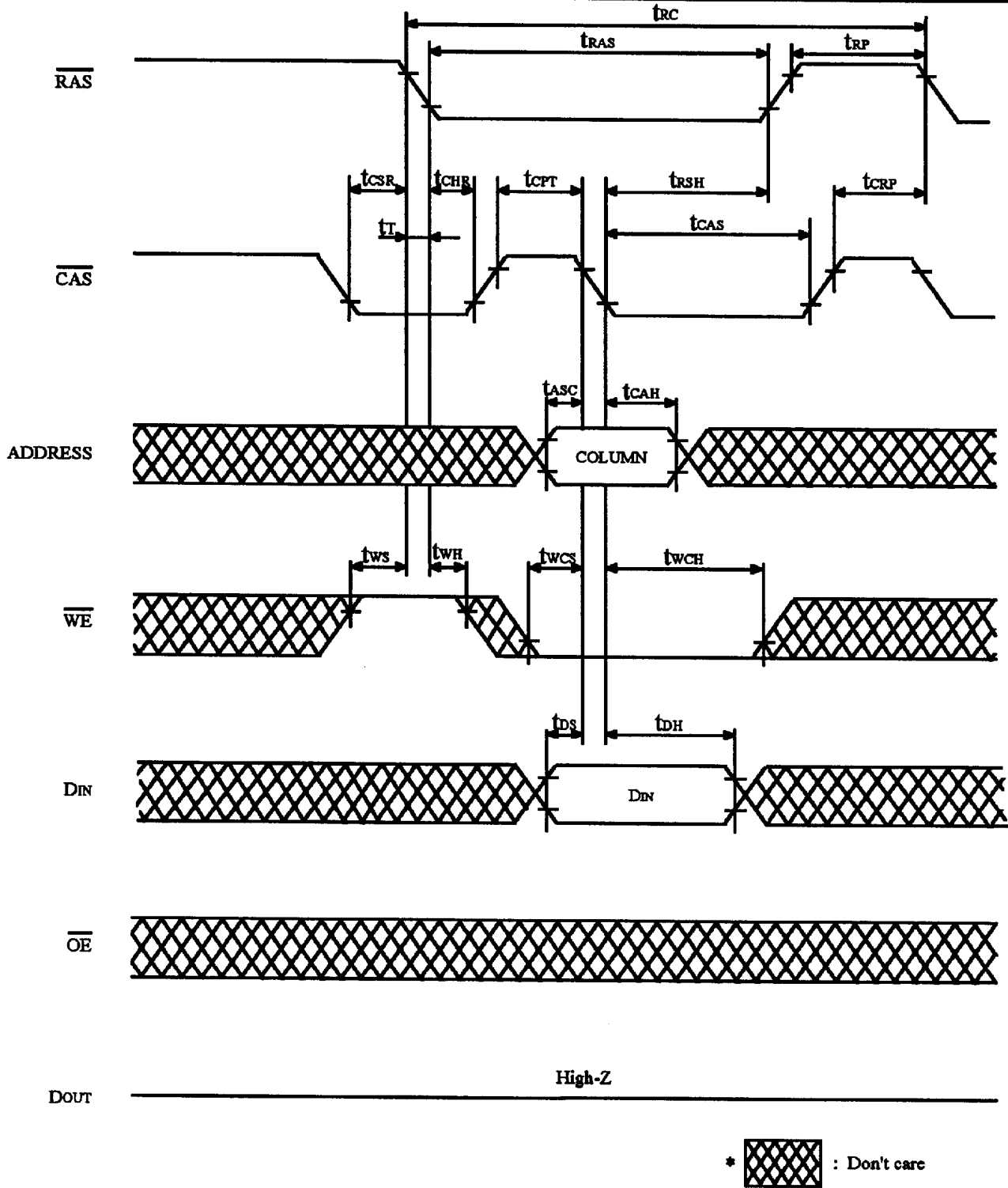
**FIGURE 14.  $\overline{\text{CAS}}$  BEFORE  $\overline{\text{RAS}}$  REFRESH CYCLE**



**FIGURE 15.  $\overline{\text{RAS}}$  ONLY REFRESH CYCLE**



**FIGURE 16.  $\overline{\text{CAS}}$  BEFORE  $\overline{\text{RAS}}$  REFRESH COUNTER CHECK CYCLE (READ)**

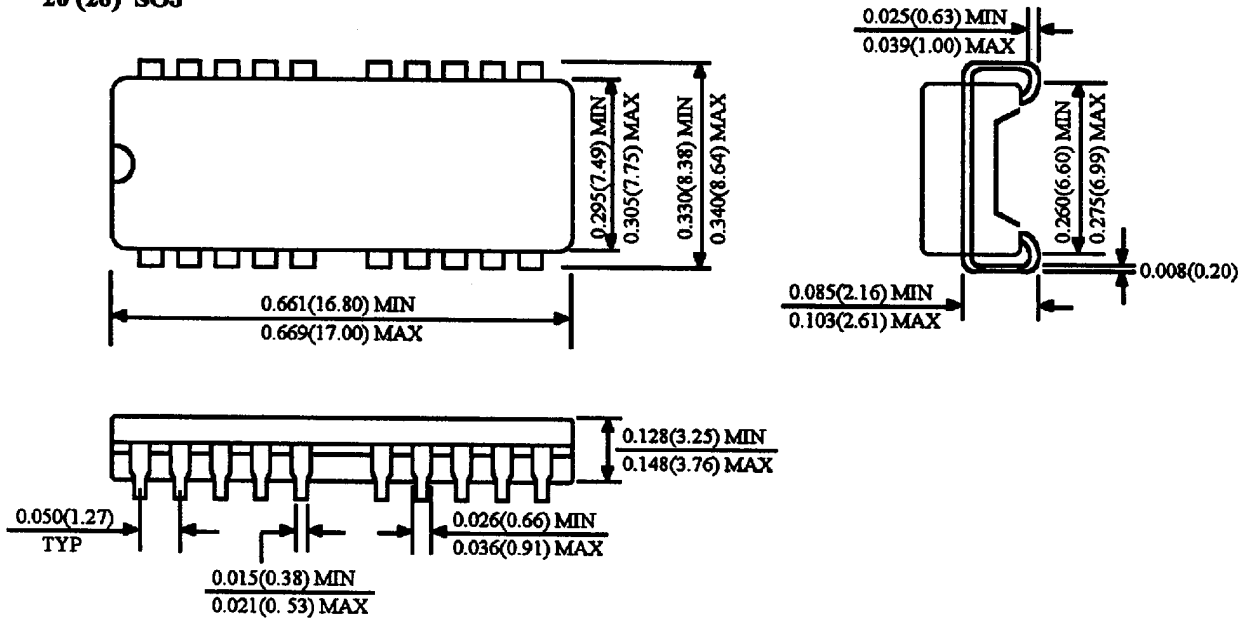


**FIGURE 17.  $\overline{\text{CAS}}$  BEFORE  $\overline{\text{RAS}}$  REFRESH COUNTER CHECK CYCLE (WRITE)**

**Package Dimension**

Unit: Inches (mm)

**20 (26) SOJ**



**20 (26) TSOP (TYPE. II)**

