

GoldStar

T-46-23-17

GM71C4256A/AL

262,144 WORDS×4 BIT
CMOS DYNAMIC RAM

Description

The GM71C4256A/AL is the new generation dynamic RAM organized 262,144×4 Bit. GM71C4256A/AL has realized higher density, higher performance and various functions by utilizing advanced CMOS process technology. The GM71C4256A/AL offers Fast Page Mode as a high speed access mode. Multiplexed address inputs permit the GM71C4256A/AL to be packaged in a standard 20 pin DIP, SOJ and ZIP. The package size provides high system bit densities and is compatible with widely available automated testing and insertion equipment. System oriented features include single power supply of 5V ± 10% tolerance, direct interfacing capability with high performance logic families such as Schottky TTL.

Features

- 262,144×4 Bit Organization
- Fast Page Mode Capability
- Single Power Supply
- Fast Access Time & Cycle Time (Unit: ns)

	t _{RAC}	t _{CAC}	t _{RC}	t _{PC}
GM71C4256A/AL-60	60	20	120	45
GM71C4256A/AL-70	70	20	130	50
GM71C4256A/AL-80	80	25	160	55
GM71C4256A/AL-10	100	25	190	55

- Low Power
Active: 495/440/385/330mW (MAX)
Standby: 11mW (CMOS level: MAX)
1.1mW (L-series)
- RAS Only Refresh, CAS before RAS Refresh, Hidden Refresh Capability
- All inputs and outputs TTL Compatible
- 512 Refresh Cycles/8ms
- 512 Refresh Cycles/64ms (L-series)
- Battery Back Up Operation (L-series)

Pin Configuration

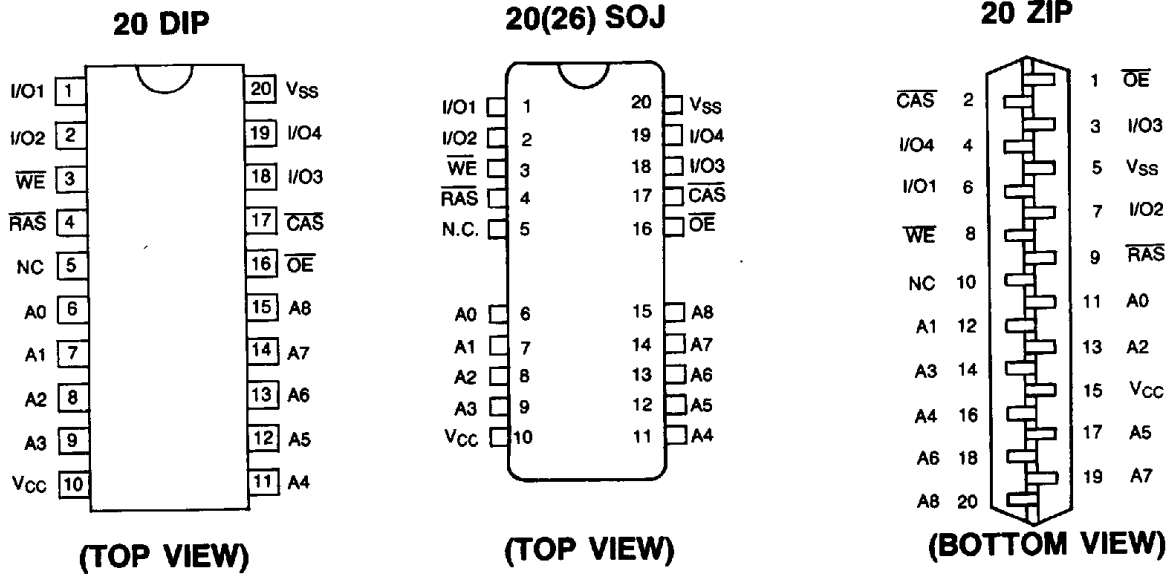

T-46-23-17

GoldStar**GM71C4256A/AL****Pin Description**

Pin	Function	Pin	Function
A0~A8	Address Inputs	I/O~I/O4	Data Input, Output
RAS	Row Address Strobe	V _{CC}	+5V Supply
CAS	Column Address Strobe	V _{SS}	Ground
\overline{WE}	Write Enable	NC	No Connection
\overline{OE}	Output Enable		

Ordering Information

Type No.	Access Time	Package
GM71C4256A/AL-60 GM71C4256A/AL-70 GM71C4256A/AL-80 GM71C4256A/AL-10	60ns 70ns 80ns 100ns	300 Mil 20 Pin Plastic DIP
GM71C4256ASJ/ALSJ-60 GM71C4256ASJ/ALSJ-70 GM71C4256ASJ/ALSJ-80 GM71C4256ASJ/ALSJ-10	60ns 70ns 80ns 100ns	300 Mil 20 (26) Pin Plastic SOJ
GM71C4256AZ/ALZ-60 GM71C4256AZ/ALZ-70 GM71C4256AZ/ALZ-80 GM71C4256AZ/ALZ-10	60ns 70ns 80ns 100ns	400 Mil 20 Pin Plastic ZIP

Absolute Maximum Ratings*

Symbol	Parameter	Rating	Unit
T _A	Ambient Temperature under Bias	0~70	°C
T _{STG}	Storage Temperature (plastic)	-55~125	°C
V _{IN} /V _{OUT}	Voltage on any Pin Relative to V _{SS}	-1.0~7.0	V
V _{CC}	Voltage on V _{CC} Relative to V _{SS}	-1.0~7.0	V
I _{OUT}	Short Circuit Output Current	50	mA
P _D	Power Dissipation	1.0	W

*Note: Operation at or above Absolute Maximum Ratings can adversely affect device reliability.

Recommended Operating Conditions (T_A=0 ~ 70°C)

Symbol	Parameter	Min	Typ	Max	Unit
V _{CC}	Supply Voltage	4.5	5.0	5.5	V
V _{IH}	Input High Voltage	2.4	—	6.5	V
V _{IL}	Input Low Voltage (I/O Pin)	-1.0	—	0.8	V
V _{IL}	Input Low Voltage (Others)	-2.0	—	0.8	V

T-46-23-17

GoldStar**GM71C4256A/AL**DC Electrical Characteristics: ($V_{CC}=5V \pm 10\%$, $T_A=0 \sim 70^\circ C$)

Symbol	Parameter	Min	Max	Unit	Note	
V_{OH}	Output Level Output "H" Level Voltage ($I_{OUT} = -5mA$)	2.4	V_{CC}	V		
V_{OL}	Output Level Output "L" Level Voltage ($I_{OUT} = 4.2mA$)	0	0.4	V		
I_{CC1}	Operating Current Average Power Supply Operating Current (RAS, CAS, Address Cycling: $t_{RC} = t_{RC} \text{ min}$)	60ns	—	90	mA	1,2
		70ns	—	80		
		80ns	—	70		
		100ns	—	60		
I_{CC2}	Standby Current (TTL) Power Supply Standby Current (RAS, CAS = V_{IH})	—	2	mA		
I_{CC3}	RAS Only Refresh Current Average Power Supply Current RAS Only Refresh Mode (RAS Cycling, CAS = V_{IH} , $t_{RC} = t_{RC} \text{ min}$)	60ns	—	90	mA	2
		70ns	—	80		
		80ns	—	70		
		100ns	—	60		
I_{CC4}	Fast Page Mode Current Average Power Supply Current Fast Page Mode (RAS = V_{IL} , CAS Cycling: $t_{PC} = t_{PC} \text{ min}$)	60ns	—	80	mA	1,3
		70ns	—	70		
		80ns	—	60		
		100ns	—	50		
I_{CC5}	Standby Current (CMOS) Power Supply Standby Current (RAS, CAS = $V_{CC} - 0.2V$)	—	1	mA	4	
		—	200	μA		
I_{CC6}	CAS before RAS Refresh Current ($t_{RC} = t_{RC} \text{ min}$)	60ns	—	80	mA	
		70ns	—	70		
		80ns	—	70		
		100ns	—	60		
I_{CC7}	Battery Back Up Current Average Power Supply Current, Battery Back Up Mode (CAS = CAS before RAS Cycling or 0.2V, $\overline{OE} = V_{CC} - 0.2V$, $\overline{WE} = V_{CC} - 0.2V$ or 0.2V, A0 ~ A8 = $V_{CC} - 0.2V$ or 0.2V, I/O1 ~ 4 = $V_{CC} - 0.2V$, 0.2V or Open: $t_{RC} = 125\mu s$)	—	300	μA	4,5	
I_{CC8}	Standby Current $\overline{RAS} = V_{IH}$ CAS = V_{IL} DOUT = Enable	—	5	mA	1	
$I_{I(L)}$	Input Leakage Current Any Input ($0V \leq V_{IN} \leq 7V$) All Other Pins Not Under Test = 0V	-10	10	μA		
$I_{O(L)}$	Output Leakage Current (DOUT is Disabled, $0V \leq V_{OUT} \leq 7V$)	-10	10	μA		

- Note 1. I_{CC} depends on output loading condition when the device is selected, $I_{CC} \text{ (max)}$ is specified at the output open condition.
2. Address can be changed less than three times while $\overline{RAS} = V_{IL}$.
3. Address can be changed once or less while CAS = V_{IH} .
4. L Series
5. $t_{RAS} \text{ (max)} = 1\mu s$ is applied to refresh of battery back up.



GM71C4256A/AL

Capacitance ($V_{CC}=5V \pm 10\%$, $T_A=25^\circ C$)

Symbol	Parameter	Min	Max	Unit	Note
C_{I1}	Input Capacitance (A0 ~ A8)	—	5	pF	1
C_{I2}	Input Capacitance (\overline{RAS} , \overline{CAS} , \overline{WE} , \overline{OE})	—	7	pF	1
$C_{I/O}$	Data Input/Data Output	—	10	pF	1,2

*Note 1. Capacitance is sampled and not 100% tested.
 2. $\overline{CAS}=V_{IH}$ to disable D_{OUT} .

AC Characteristics ($V_{CC}=5V \pm 10\%$, $T_A=0 \sim 70^\circ C$, Note 1,14)

Read, Write, Read-Modify-Write and Refresh Cycles (Common Parameters)

Symbol	Parameter	GM71C4256A/AL-60		GM71C4256A/AL-70		GM71C4256A/AL-80		GM71C4256A/AL-10		Unit	Note
		Min	Max	Min	Max	Min	Max	Min	Max		
t_{RC}	Random Read or Write Cycle Time	120	—	130	—	160	—	190	—	ns	
t_{RP}	\overline{RAS} Precharge Time	50	—	50	—	70	—	80	—	ns	
t_{RAS}	\overline{RAS} Pulse Width	60	10,000	70	10,000	80	10,000	100	10,000	ns	
t_{CAS}	\overline{CAS} Pulse Width	20	10,000	20	10,000	25	10,000	25	10,000	ns	
t_{ASR}	Row Address Set-up Time	0	—	0	—	0	—	0	—	ns	
t_{RAH}	Row Address Hold Time	10	—	10	—	12	—	15	—	ns	
t_{ASC}	Column Address Set-up Time	0	—	0	—	0	—	0	—	ns	
t_{CAH}	Column Address Hold Time	15	—	15	—	20	—	20	—	ns	
t_{RCD}	\overline{RAS} to \overline{CAS} Delay Time	20	40	20	50	22	55	25	75	ns	8
t_{RAD}	\overline{RAS} to Column Address Delay Time	15	30	15	35	17	40	20	55	ns	9
t_{RSH}	\overline{RAS} Hold Time	20	—	20	—	25	—	25	—	ns	
t_{CSH}	\overline{CAS} Hold Time	60	—	70	—	80	—	100	—	ns	
t_{CRP}	\overline{CAS} to \overline{RAS} Precharge Time	10	—	10	—	10	—	10	—	ns	
t_{ODD}	\overline{OE} to D_{IN} Delay Time	20	—	20	—	20	—	25	—	ns	
t_{DZO}	\overline{OE} Delay Time from D_{IN}	0	—	0	—	0	—	0	—	ns	
t_{DZC}	\overline{CAS} Delay Time from D_{IN}	0	—	0	—	0	—	0	—	ns	
t_T	Transition Time (Rise and Fall)	3	50	3	50	3	50	3	50	ns	7
t_{REF}	Refresh Period	—	8	—	8	—	8	—	8	ms	
	Refresh Period (L-Series)	—	64	—	64	—	64	—	64	ms	

T-46-23-17

GoldStar**GM71C4256A/AL****Read Cycle**

Symbol	Parameter	GM71C4256A/AL-60		GM71C4256A/AL-70		GM71C4256A/AL-80		GM71C4256A/AL-10		Unit	Note
		Min	Max	Min	Max	Min	Max	Min	Max		
t _{RAC}	Access Time from $\overline{\text{RAS}}$	—	60	—	70	—	80	—	100	ns	2,3
t _{CAC}	Access Time from $\overline{\text{CAS}}$	—	20	—	20	—	25	—	25	ns	3,4
t _{AA}	Access Time from Column Address	—	30	—	35	—	40	—	45	ns	3,5
t _{OAC}	Access Time from $\overline{\text{OE}}$	—	20	—	20	—	25	—	25	ns	
t _{RCS}	Read Command Set-up Time	0	—	0	—	0	—	0	—	ns	
t _{RCH}	Read Command Hold Time to $\overline{\text{CAS}}$	0	—	0	—	0	—	0	—	ns	
t _{RRH}	Read Command Hold Time to $\overline{\text{RAS}}$	10	—	10	—	10	—	10	—	ns	
t _{RAL}	Column Address to $\overline{\text{RAS}}$ Lead Time	30	—	35	—	40	—	45	—	ns	
t _{OFF1}	Output Buffer Turn-off Delay Time	—	20	—	20	—	20	—	25	ns	6
t _{OFF2}	Output Buffer Turn-off Delay Time from $\overline{\text{OE}}$	—	20	—	20	—	20	—	25	ns	6
t _{CDD}	$\overline{\text{CAS}}$ to $\overline{\text{DIN}}$ Delay Time	20	—	20	—	20	—	25	—	ns	

Write Cycle

Symbol	Parameter	GM71C4256A/AL-60		GM71C4256A/AL-70		GM71C4256A/AL-80		GM71C4256A/AL-10		Unit	Note
		Min	Max	Min	Max	Min	Max	Min	Max		
t _{WCS}	Write Command Set-up Time	0	—	0	—	0	—	0	—	ns	10
t _{WCH}	Write Command Hold Time	15	—	15	—	20	—	20	—	ns	
t _{WP}	Write Command Pulse Width	10	—	10	—	15	—	15	—	ns	
t _{RWL}	Write Command to $\overline{\text{RAS}}$ Lead Time	20	—	20	—	25	—	25	—	ns	
t _{CWL}	Write Command to $\overline{\text{CAS}}$ Lead Time	20	—	20	—	25	—	25	—	ns	
t _{DS}	Data-in Set-up Time	0	—	0	—	0	—	0	—	ns	11
t _{DH}	Data-in Hold Time	15	—	15	—	20	—	20	—	ns	11



GM71C4256A/AL

Read-Modify-Write Cycle

Symbol	Parameter	GM71C4256A/AL-60		GM71C4256A/AL-70		GM71C4256A/AL-80		GM71C4256A/AL-10		Unit	Note
		Min	Max	Min	Max	Min	Max	Min	Max		
trWC	Read-Write Cycle Time	170	—	180	—	220	—	255	—	ns	
trWD	$\overline{\text{RAS}}$ to $\overline{\text{WE}}$ Delay Time	85	—	95	—	110	—	135	—	ns	10
tcWD	$\overline{\text{CAS}}$ to $\overline{\text{WE}}$ Delay Time	45	—	45	—	55	—	60	—	ns	10
tAWD	Column Address to $\overline{\text{WE}}$ Delay Time	55	—	60	—	70	—	80	—	ns	10
toEH	$\overline{\text{OE}}$ Hold Time from $\overline{\text{WE}}$	20	—	20	—	25	—	25	—	ns	

Refresh Cycle

Symbol	Parameter	GM71C4256A/AL-60		GM71C4256A/AL-70		GM71C4256A/AL-80		GM71C4256A/AL-10		Unit	Note
		Min	Max	Min	Max	Min	Max	Min	Max		
tCSR	$\overline{\text{CAS}}$ Set-up Time ($\overline{\text{CAS}}$ -before- $\overline{\text{RAS}}$ Refresh Cycle)	10	—	10	—	10	—	10	—	ns	
tCHR	$\overline{\text{CAS}}$ Hold Time ($\overline{\text{CAS}}$ -before- $\overline{\text{RAS}}$ Refresh Cycle)	15	—	15	—	20	—	20	—	ns	
trPC	$\overline{\text{RAS}}$ Precharge to $\overline{\text{CAS}}$ Hold Time	10	—	10	—	10	—	10	—	ns	

Fast Page Mode Cycle

Symbol	Parameter	GM71C4256A/AL-60		GM71C4256A/AL-70		GM71C4256A/AL-80		GM71C4256A/AL-10		Unit	Note
		Min	Max	Min	Max	Min	Max	Min	Max		
tpC	Fast Page Mode Cycle Time	45	—	50	—	55	—	55	—	ns	
tcp	Fast Page Mode $\overline{\text{CAS}}$ Precharge Time	10	—	10	—	10	—	10	—	ns	
trASC	Fast Page Mode $\overline{\text{RAS}}$ Pulse Width	—	100,000	—	100,000	—	100,000	—	100,000	ns	12
tACP	Access Time from $\overline{\text{CAS}}$ Precharge	—	40	—	45	—	50	—	50	ns	13
trHCP	$\overline{\text{RAS}}$ Hold Time from $\overline{\text{CAS}}$ Precharge	40	—	45	—	50	—	50	—	ns	

Fast Page Mode Read-Modify-Write Cycle

Symbol	Parameter	GM71C4256A/AL-60		GM71C4256A/AL-70		GM71C4256A/AL-80		GM71C4256A/AL-10		Unit	Note
		Min	Max	Min	Max	Min	Max	Min	Max		
tpCM	Fast Page Mode Read-Modify-Write Cycle Time	95	—	100	—	110	—	115	—	ns	

GoldStar**GM71C4256A/AL**

Notes :

1. AC measurements assume $t_T = 5\text{ns}$.
2. Assumes that $t_{\text{RCD}} \leq t_{\text{RCD}}(\text{max})$ and $t_{\text{RAD}} \leq t_{\text{RAD}}(\text{max})$. If t_{RCD} or t_{RAD} is greater than the maximum recommended value shown in this table, t_{RAC} exceeds the value shown.
3. Measured with a load circuit equivalent to 2 TTL loads and 100pF.
4. Assumes that $t_{\text{RCD}} \geq t_{\text{RCD}}(\text{max})$ and $t_{\text{RAD}} \leq t_{\text{RAD}}(\text{max})$.
5. Assumes that $t_{\text{RCD}} \leq t_{\text{RCD}}(\text{max})$ and $t_{\text{RAD}} \geq t_{\text{RAD}}(\text{max})$.
6. $t_{\text{OFF}}(\text{max})$ defines the time at which the output achieves the open circuit condition and is not referenced to output voltage levels.
7. $V_{\text{IH}}(\text{min})$ and $V_{\text{IL}}(\text{max})$ are reference levels for measuring timing of input signals. Also transition times are measured between V_{IH} and V_{IL} .
8. Operation with the $t_{\text{RCD}}(\text{max})$ limit insures that $t_{\text{RAC}}(\text{max})$ can be met. $t_{\text{RCD}}(\text{max})$ is specified as a reference point only: if t_{RCD} is greater than the specified $t_{\text{RCD}}(\text{max})$ limit, then access time is controlled exclusively by t_{CAC} .
9. Operation with the $t_{\text{RAD}}(\text{max})$ limit insures that $t_{\text{RAC}}(\text{max})$ can be met. $t_{\text{RAD}}(\text{max})$ is specified as a reference point only: if t_{RAD} is greater than the specified $t_{\text{RAD}}(\text{max})$ limit, then access time is controlled exclusively by t_{AA} .
10. t_{WCS} , t_{RWd} , t_{CWD} and t_{AWd} are not restrictive operating parameters. They are included in the data sheet as electrical characteristics only : if $t_{\text{WCS}} \geq t_{\text{WCS}}(\text{min})$, the cycle is an early write cycle and the data out pin will remain open circuit (high impedance) throughout the entire cycle : if $t_{\text{RWd}} \geq t_{\text{RWd}}(\text{min})$, $t_{\text{CWD}} \geq t_{\text{CWD}}(\text{min})$ and $t_{\text{AWd}} \geq t_{\text{AWd}}(\text{min})$, the cycle is a read-write and the data output will contain data read from the selected cell : if neither of the above sets of conditions is satisfied, the condition of the data out (at access time) is indeterminate.
11. These parameters are referenced to $\overline{\text{CAS}}$ leading edge in early write cycles and to $\overline{\text{WE}}$ leading edge in delayed write or Read-Modify-Write cycles.
12. t_{RASC} defines $\overline{\text{RAS}}$ pulse width in Fast Page Mode cycles.
13. Access time is determined by the longer of t_{AA} or t_{CAC} or t_{ACP} .
14. An initial pause of 100 μs is required after power up followed by a minimum of eight initialization cycles (any combination of cycles containing $\overline{\text{RAS}}$ clock such as $\overline{\text{RAS}}$ only refresh). If the internal refresh counter is used, a minimum of eight $\overline{\text{CAS}}$ -before- $\overline{\text{RAS}}$ refresh cycles are required.

TIMING WAVEFORMS

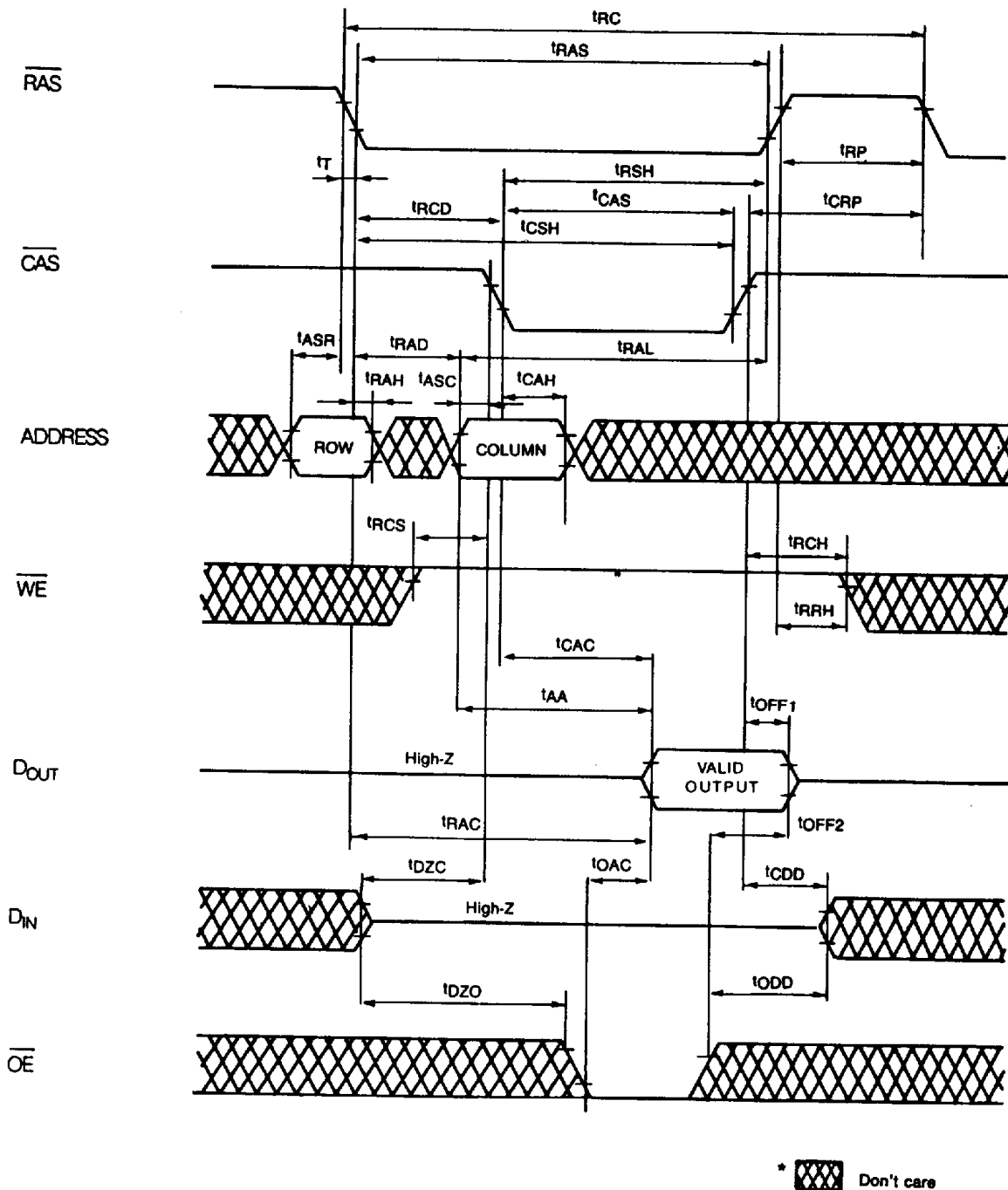

FIGURE 1. READ CYCLE

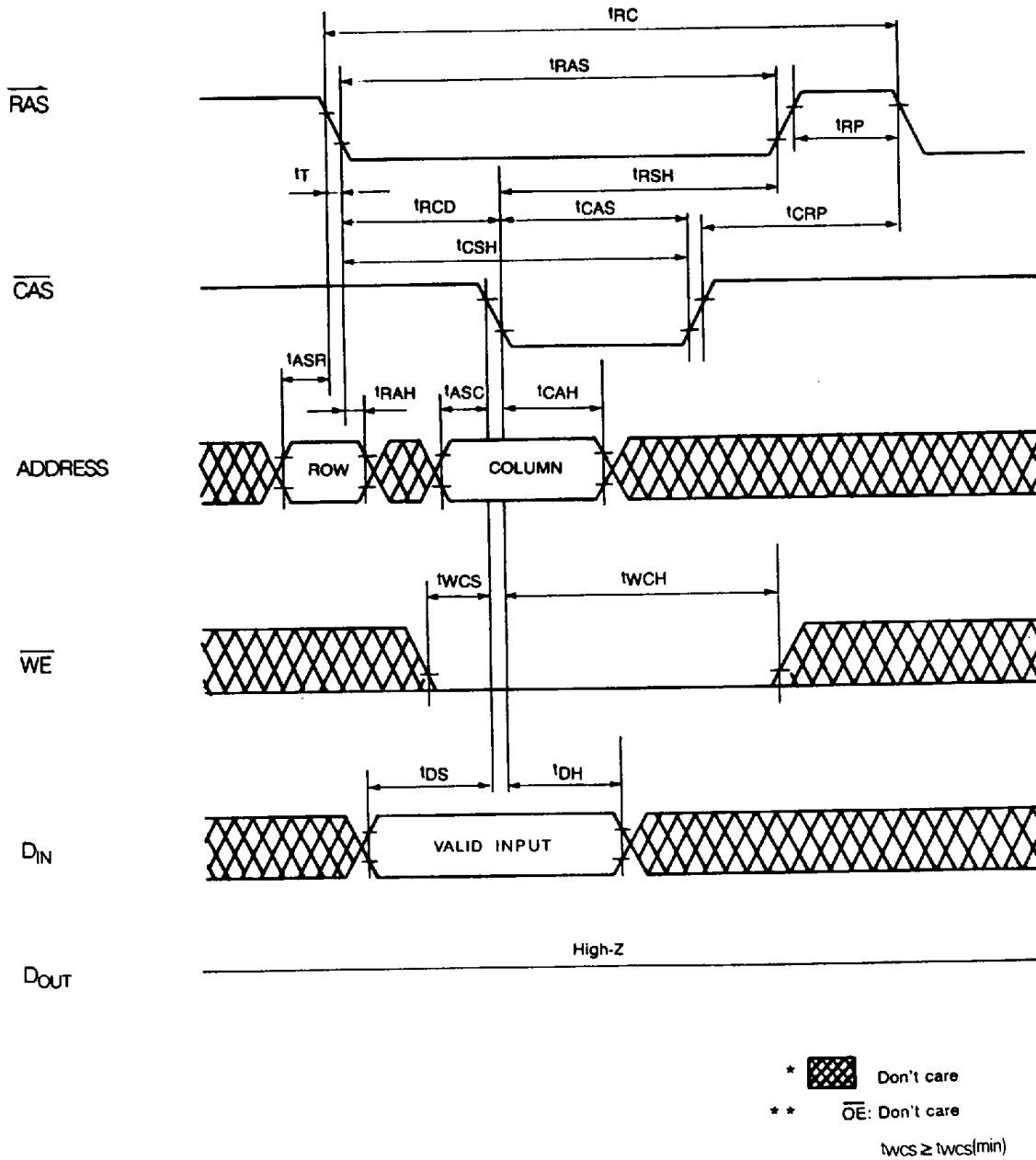

FIGURE 2. EARLY WRITE CYCLE

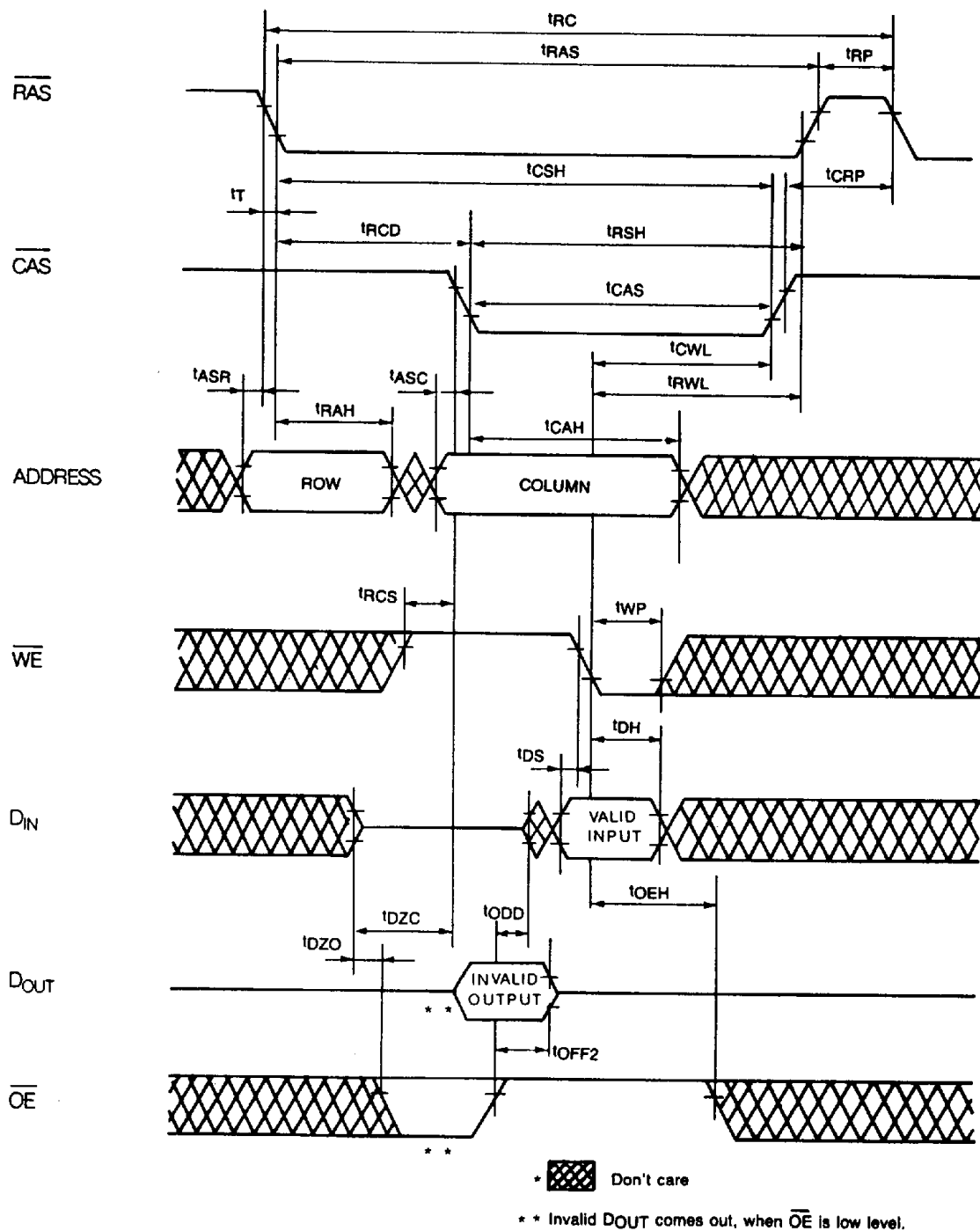

FIGURE 3. DELAYED WRITE CYCLE

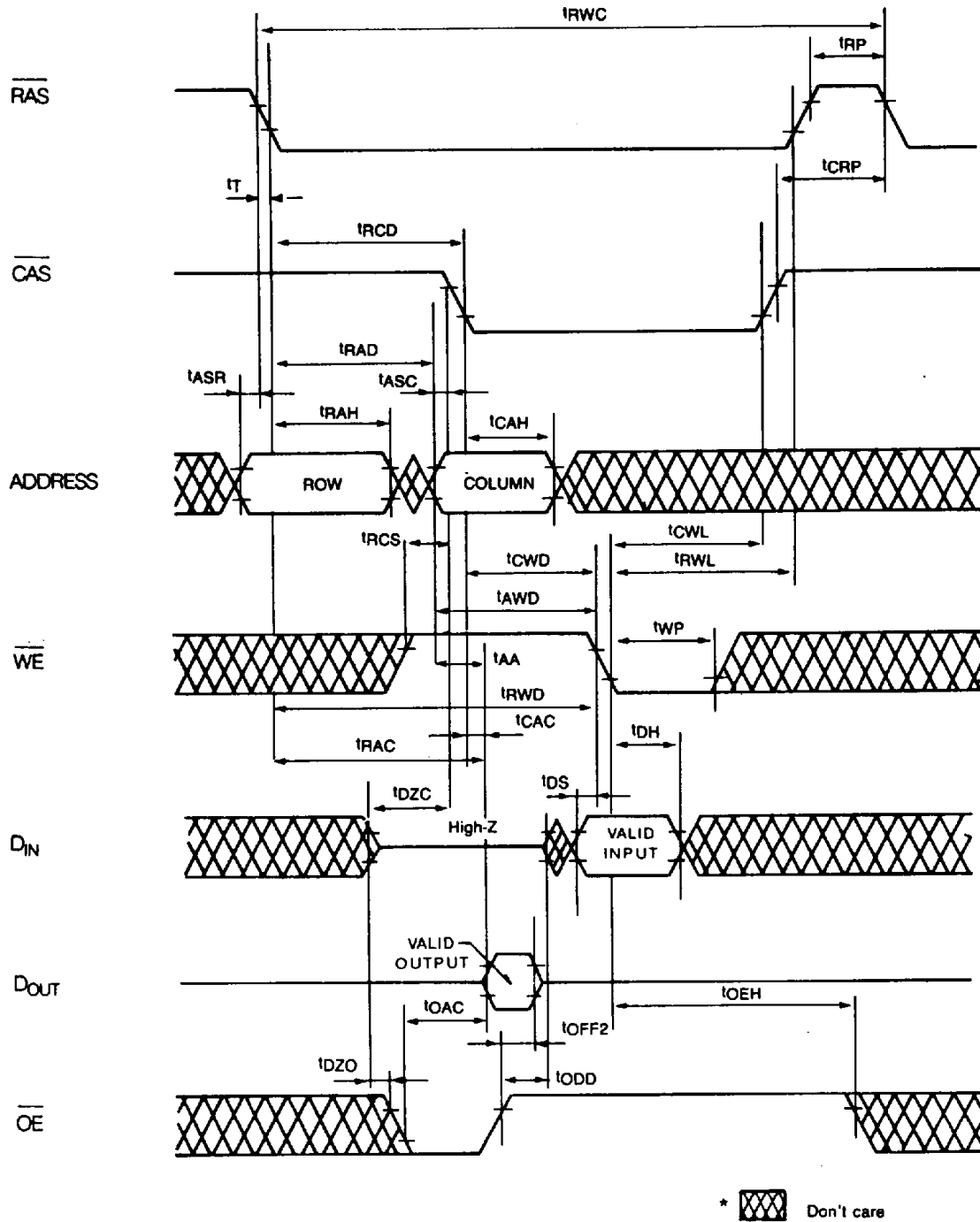

FIGURE 4. READ-MODIFY-WRITE CYCLE

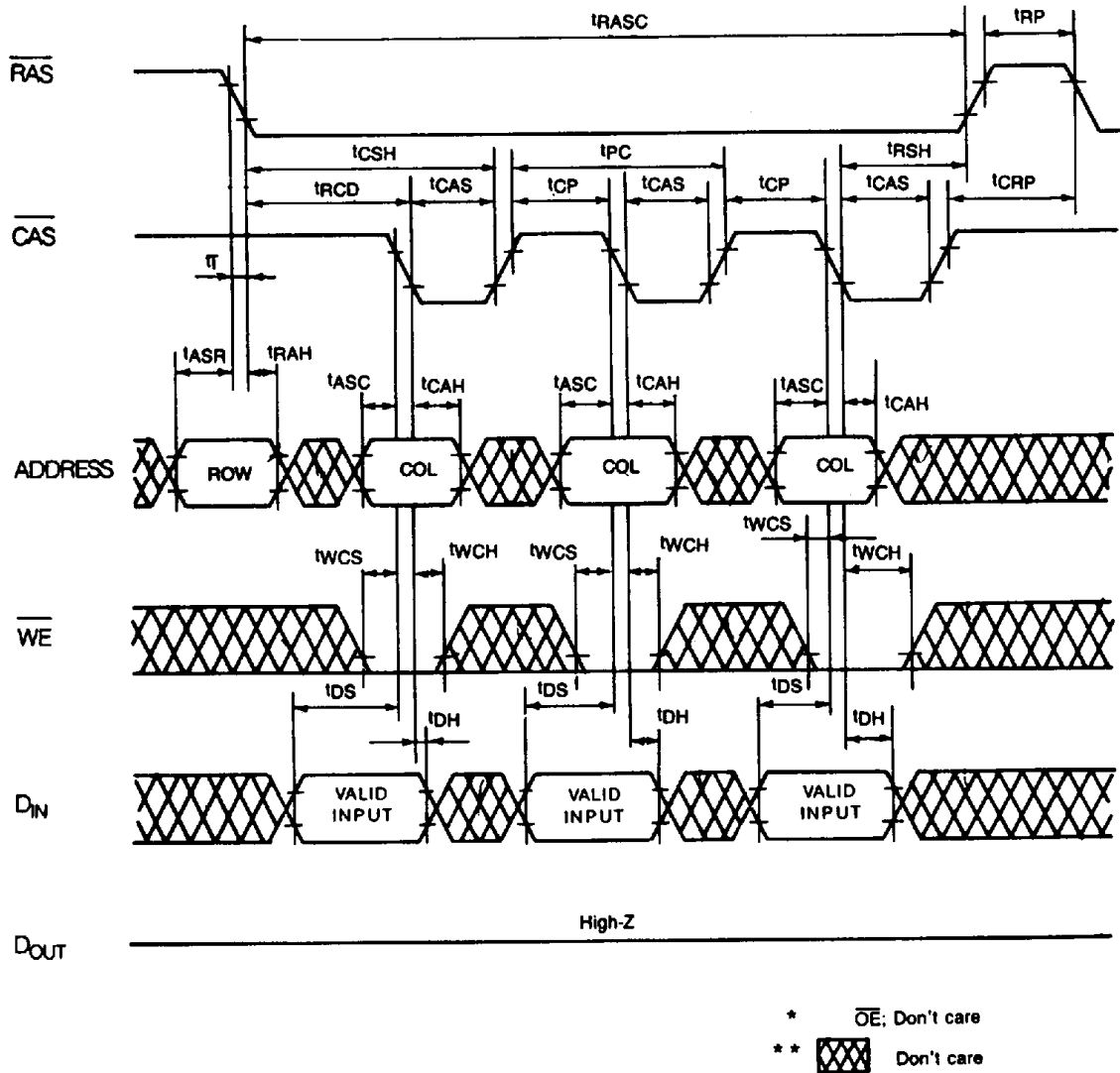

FIGURE 6. FAST PAGE MODE EARLY WRITE CYCLE

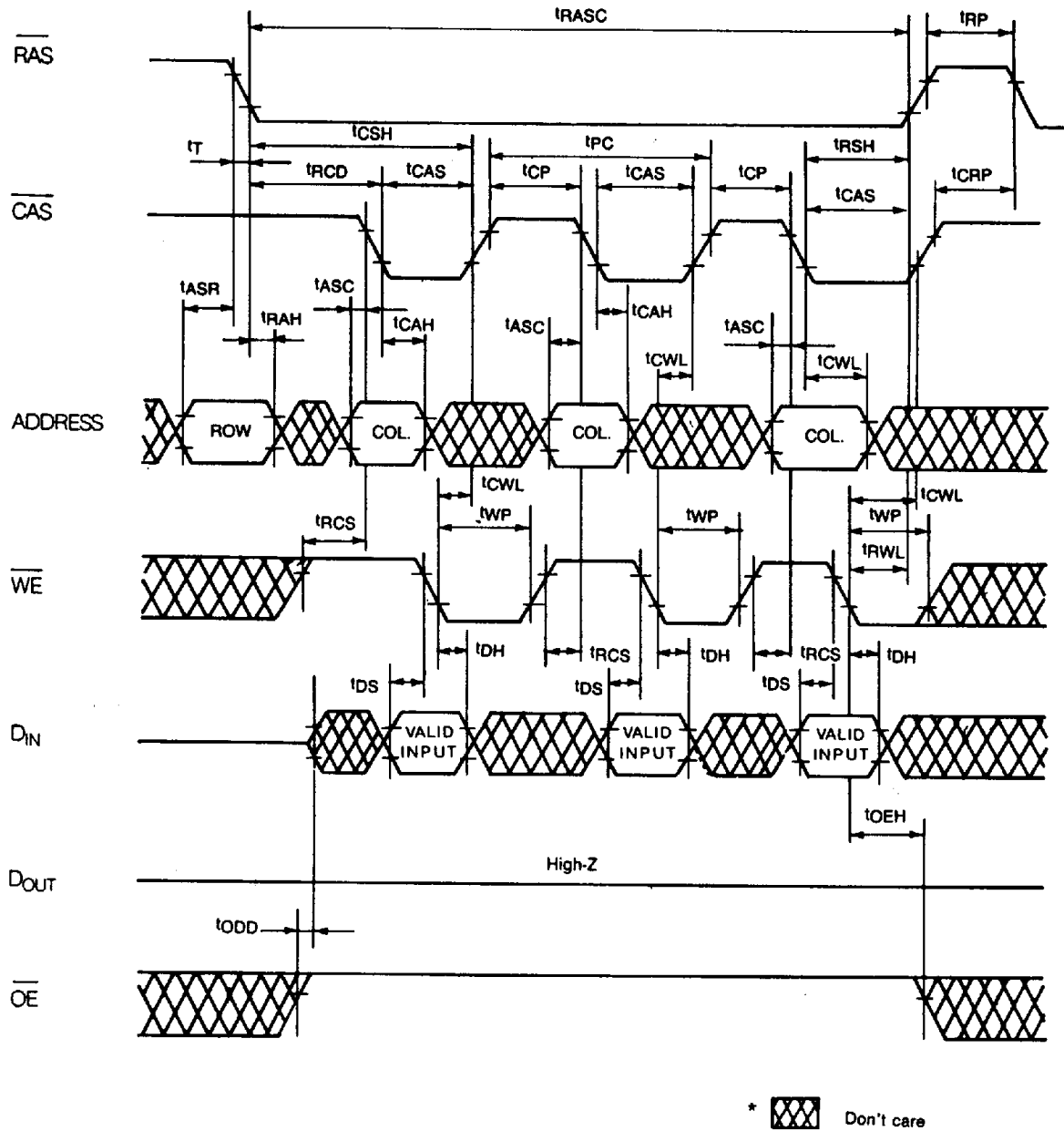

FIGURE 7. FAST PAGE MODE DELAYED WRITE CYCLE

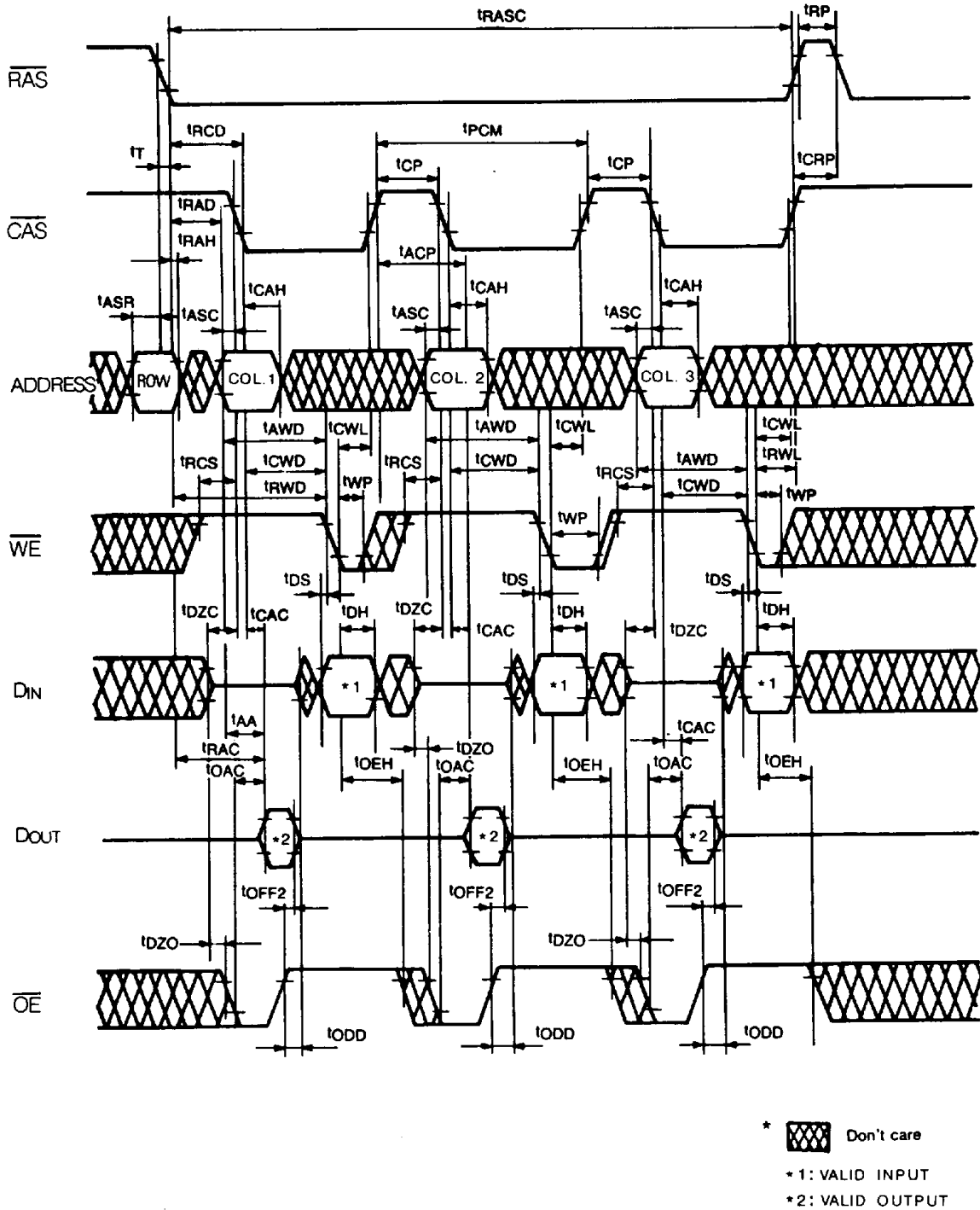

FIGURE 8. FAST PAGE MODE READ-MODIFY-WRITE CYCLE

T-46-23-17

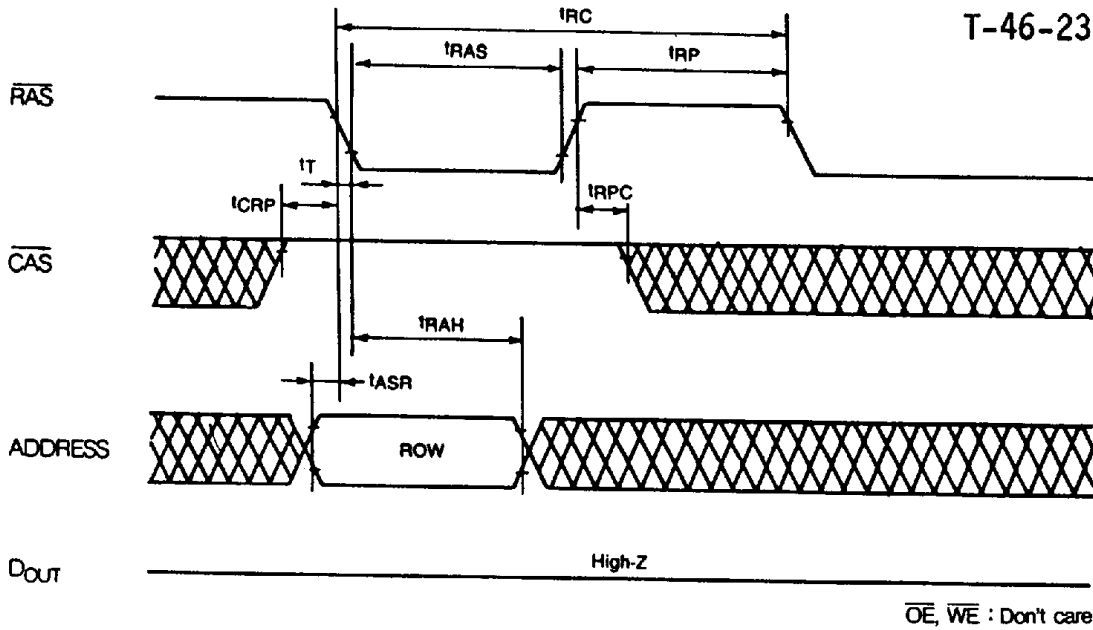

FIGURE 9. $\overline{\text{RAS}}$ -ONLY-REFRESH CYCLE

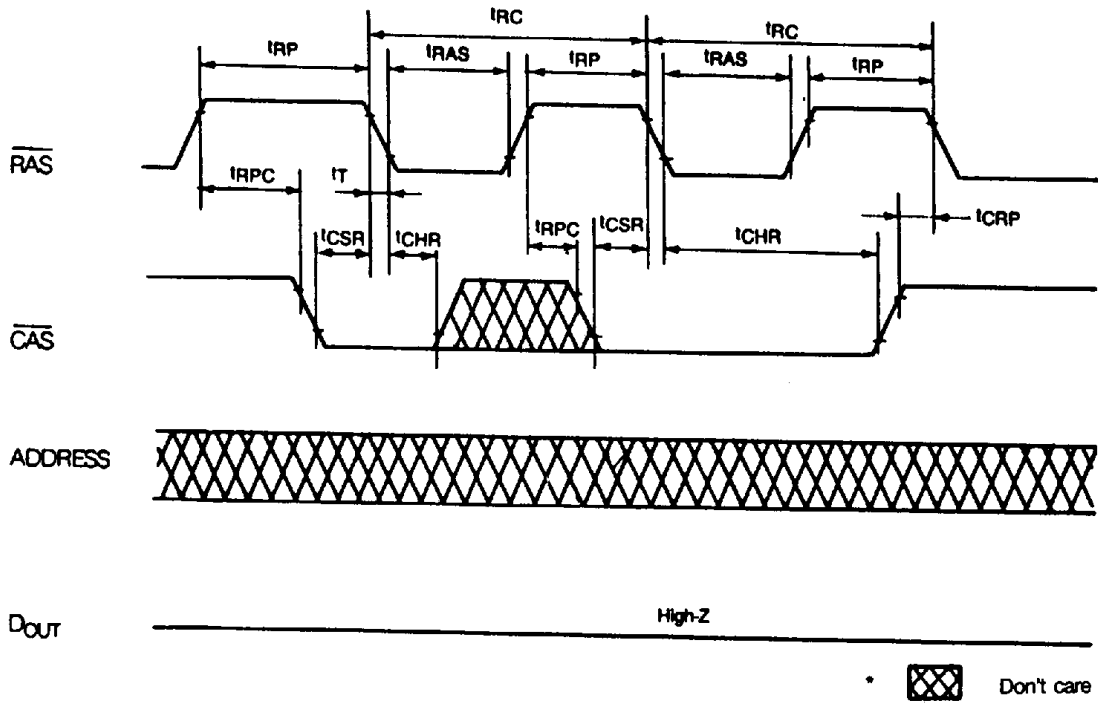

FIGURE 10. $\overline{\text{CAS}}$ BEFORE $\overline{\text{RAS}}$ REFRESH CYCLE

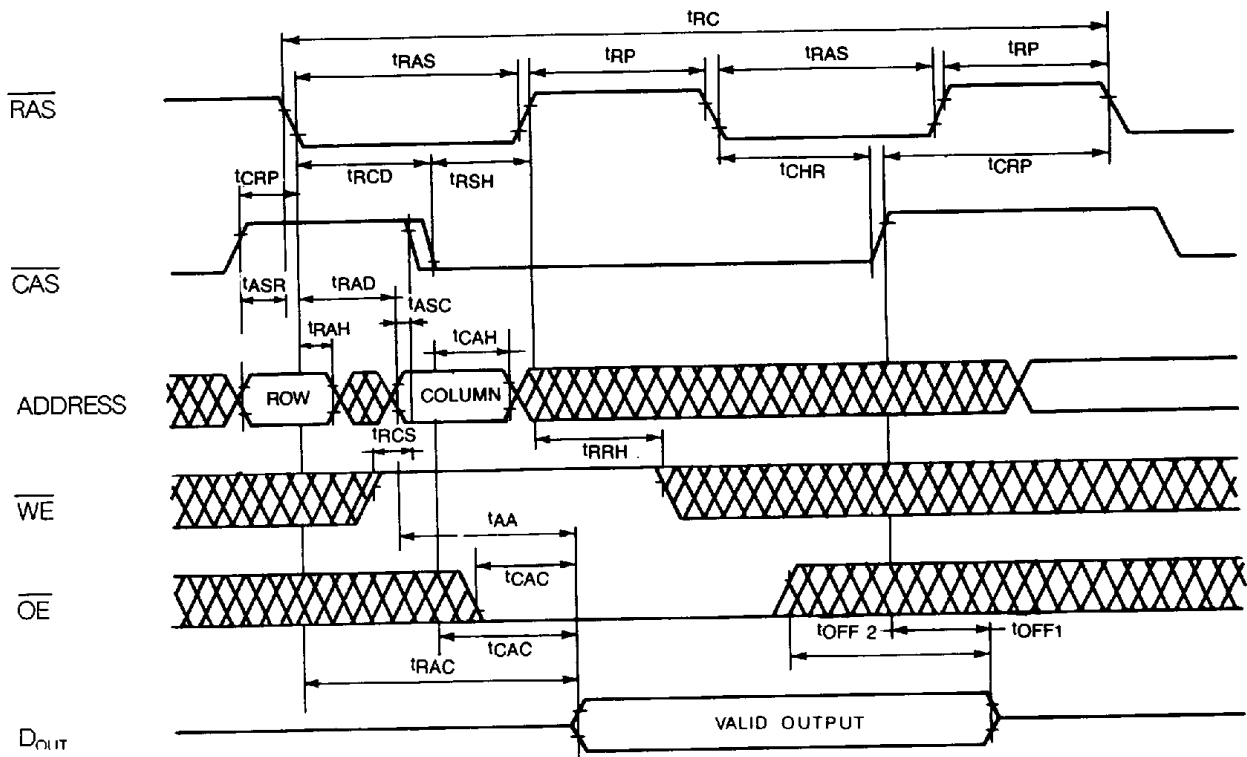

FIGURE 11. HIDDEN REFRESH CYCLE (READ)

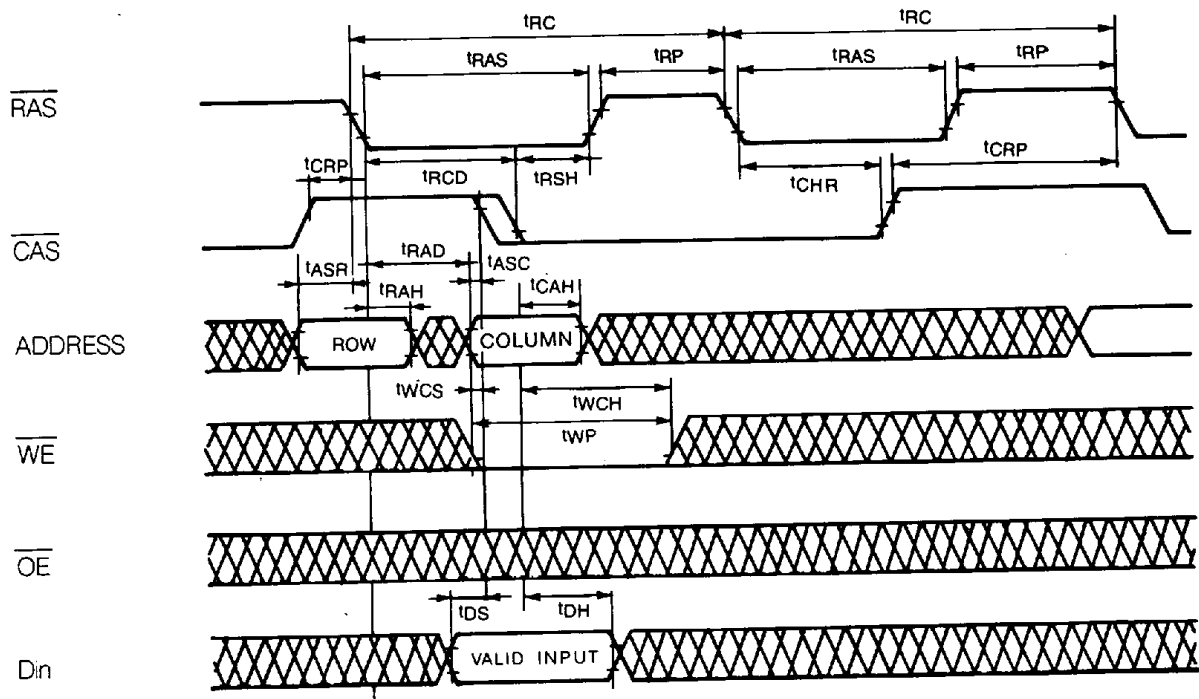

FIGURE 12. HIDDEN REFRESH CYCLE (WRITE)

GoldStar

GM71C4256A/AL

Package Dimensions

20 DIP

Unit: inches (mm)

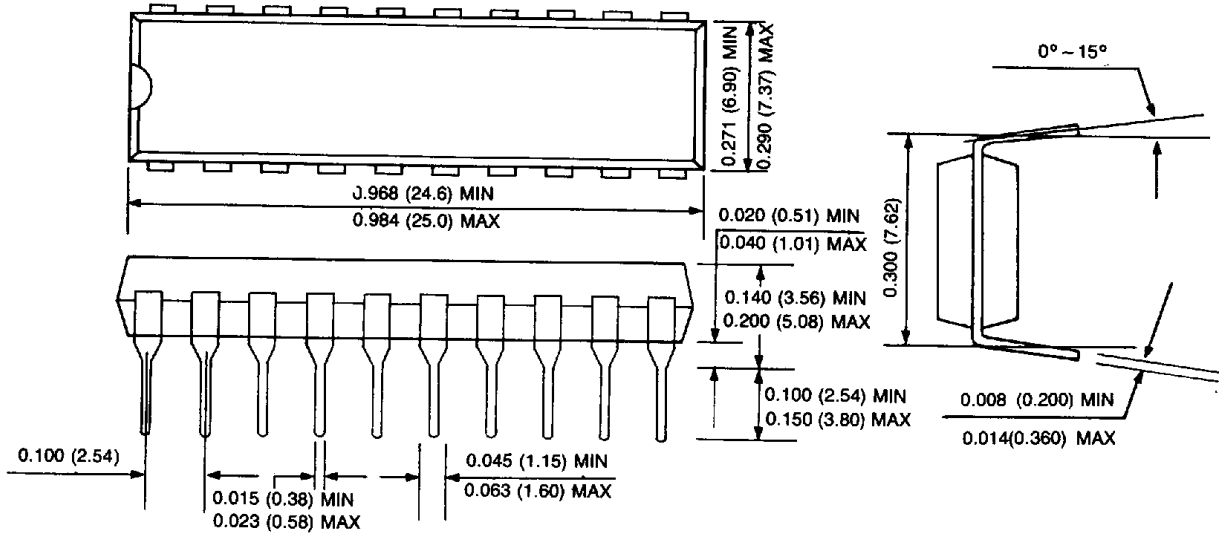

20 SOJ

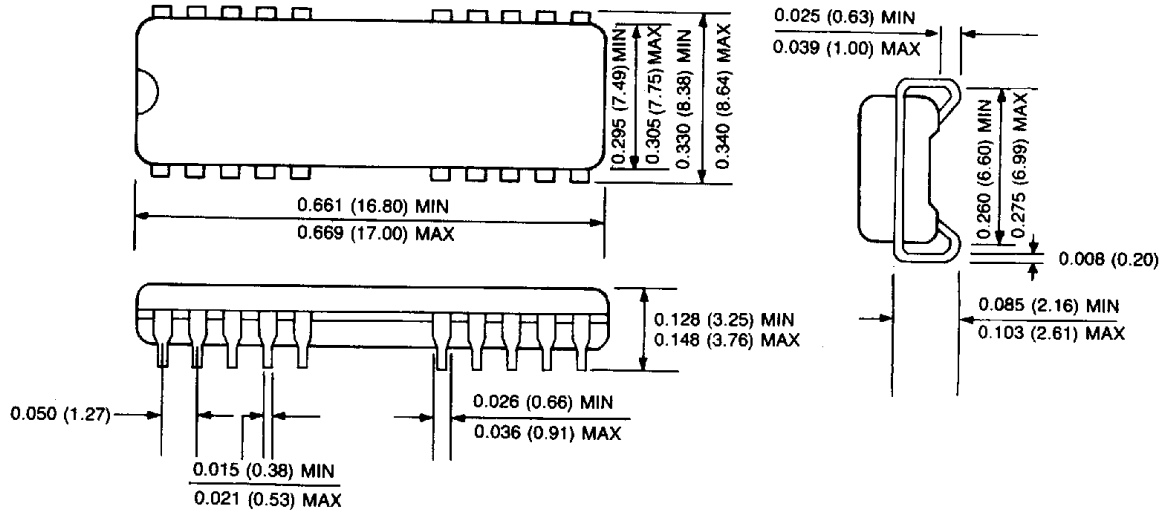

20 ZIP

