

---

## LOW VOLTAGE DETECTOR

---

NO.EA-056-070829

### OUTLINE

The R3111x series are CMOS-based voltage detector ICs with high detector threshold accuracy and ultra-low supply current, which can be operated at an extremely low voltage and is used for system reset as an example.

Each of these ICs consists of a voltage reference unit, a comparator, resistors for detector threshold setting, an output driver and a hysteresis circuit. The detector threshold is fixed with high accuracy internally and does not require any adjustment.

Three output types, Nch open drain "L" type, Nch open drain "H" type and CMOS type are available.

The R3111x Series are operable at a lower voltage than that for the Rx5VL series, and can be driven by a single battery.

Six types of packages, TO-92, SOT-89, SOT-23-3, SOT-23-5, SC-82AB, and SON1612-6 are available.

### FEATURES

- Supply Current ..... Typ. 0.8 $\mu$ A ( $V_{DD}=1.5V$ )
- Range of Operating Voltage.....0.7V to 10.0V ( $T_{opt}=25^{\circ}C$ )
- Detector Threshold.....0.9V to 6.0V
- Accuracy Detector Threshold..... $\pm 2.0\%$
- Temperature-Drift Coefficient of Detector Threshold ..... Typ.  $\pm 100ppm/^{\circ}C$
- Output Types.....Nch Open Drain "L", Nch Open Drain "H", and CMOS
- Packages .....TO-92, SOT-89, SOT-23-3, SOT-23-5, SC-82AB, SON1612-6

### APPLICATIONS

- CPU and Logic Circuit Reset
- Battery Checker
- Window Comparator
- Wave Shaping Circuit
- Battery Back-up Circuit
- Power Failure Detector

## BLOCK DIAGRAMS

R3111xxxxA

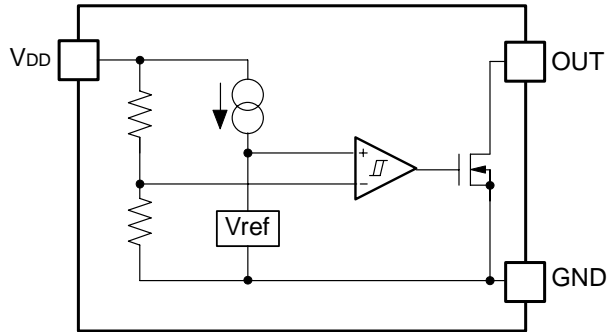

R3111xxxxB

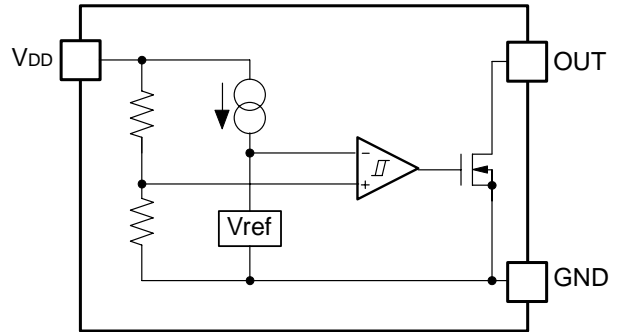

R3111xxxxC

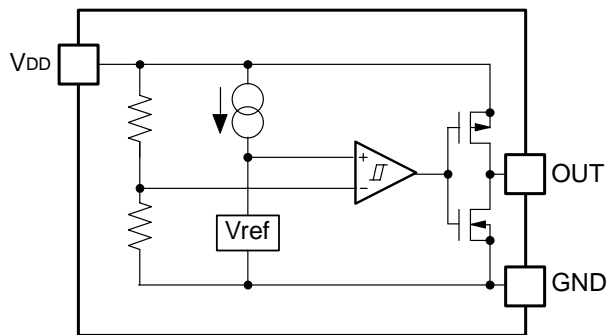

## SELECTION GUIDE

The package type, the detector threshold, the output type and the taping type for the ICs can be selected at the users' request. The selection can be made with designating the part number as shown below;

R3111XXXX-XX-X ← Part Number  
 ↑ ↑ ↑ ↑ ↑ ↑  
 a b c d e f

Code	Contents
a	Designation of Package Type; D: SON1612-6 E: TO-92 H: SOT-89 N: SOT-23-5, SOT-23-3 Q: SC-82AB
b	Setting Detector Threshold ( $-V_{DET}$ ); Stepwise setting with a step of 0.1V in the range of 0.9V to 6.0V is possible.
c	Designation of Package Type 1: except SOT-23-3 2: SOT-23-3
d	Designation of Output Type; A: Nch Open Drain (Output "L" at $V_{DD}=-V_{DET}$ ) B: Nch Open Drain (Output "H" at $V_{DD}=-V_{DET}$ ) C: CMOS (Output "L" at $V_{DD}=-V_{DET}$ )
e	Designation of Packing or Taping Type ; Ex.TO-92: TZ, SOT-89: T1, SOT-23-3, SOT-23-5, SC-82AB, SON1612-6: TR prescribed as standard directions. (Refer to Taping Specifications.) Antistatic bag for TO-92: C
f	Designation of Composition of pin plating -F: Lead free plating (TO-92, SOT-89, SOT-23-3, SOT-23-5, SC-82AB, SON1612-6)

## PIN CONFIGURATIONS

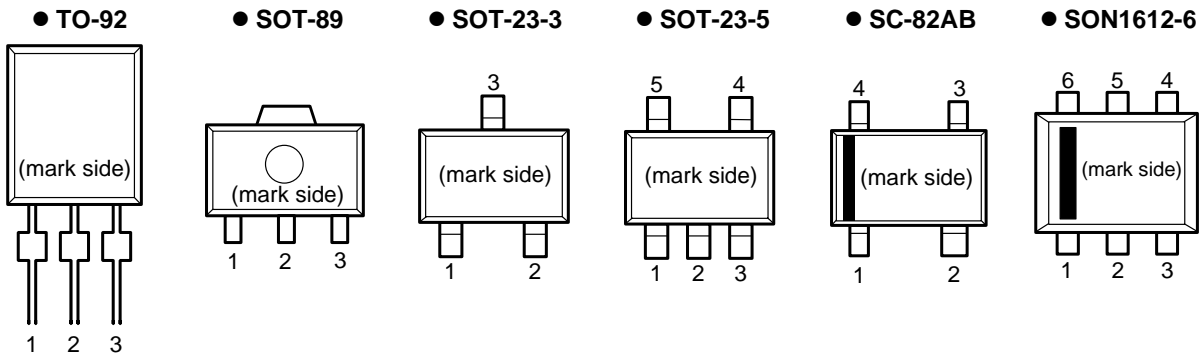

## PIN DESCRIPTIONS

● TO-92		● SOT-89		● SOT-23-3	
Pin No.	Symbol	Pin No.	Symbol	Pin No.	Symbol
1	V <sub>DD</sub>	1	OUT	1	OUT
2	GND	2	V <sub>DD</sub>	2	GND
3	OUT	3	GND	3	V <sub>DD</sub>

● SOT-23-5		● SC-82AB		● SON1612-6	
Pin No.	Symbol	Pin No.	Symbol	Pin No.	Symbol
1	OUT	1	OUT	1	OUT
2	V <sub>DD</sub>	2	V <sub>DD</sub>	2	V <sub>DD</sub>
3	GND	3	NC	3	GND
4	NC	4	GND	4	NC
5	NC			5	V <sub>DD</sub>
				6	NC

## ABSOLUTE MAXIMUM RATINGS

Symbol	Item	Rating	Unit
$V_{DD}$	Supply Voltage	12	V
$V_{OUT1}$	Output Voltage (CMOS)	$V_{SS}-0.3$ to $V_{DD}+0.3$	V
$V_{OUT2}$	Output Voltage (Nch)	$V_{SS}-0.3$ to 12	V
$I_{OUT}$	Output Current	70	mA
$P_D$	Power Dissipation (TO-92)*	300	mW
	Power Dissipation (SOT-89)*	900	
	Power Dissipation (SOT-23-3)*	420	
	Power Dissipation (SOT-23-5)*	420	
	Power Dissipation (SC-82AB)*	380	
	Power Dissipation (SON1612-6)*	500	
$T_{opt}$	Operating Temperature Range	-40 to 85	°C
$T_{stg}$	Storage Temperature Range	-55 to 125	°C
$T_{solder}$	Lead temperature (Soldering)	260°C, 10s	

\* ) For Power Dissipation, please refer to PACKAGE INFORMATION to be described.

## ELECTRICAL CHARACTERISTICS

## ● R3111x09xA/C

T<sub>opt</sub>=25°C

Symbol	Item	Conditions	Min.	Typ.	Max.	Unit
-V <sub>DET</sub>	Detector Threshold		0.882	0.900	0.918	V
V <sub>HYS</sub>	Detector Threshold Hysteresis		0.027	0.045	0.063	V
I <sub>SS</sub>	Supply Current	V <sub>DD</sub> =0.80V V <sub>DD</sub> =2.90V		0.8 0.9	2.4 2.7	μA
V <sub>DDH</sub>	Maximum Operating Voltage				10	V
V <sub>DDL</sub>	Minimum Operating Voltage* <sup>Note1</sup>	T <sub>opt</sub> =25°C		0.55	0.70	V
		-40°C ≤ T <sub>opt</sub> ≤ 85°C		0.65	0.80	
I <sub>OUT</sub>	Output Current (Driver Output Pin)	Nch V <sub>DS</sub> =0.05V, V <sub>DD</sub> =0.70V V <sub>DS</sub> =0.50V, V <sub>DD</sub> =0.85V	0.01 0.05	0.05 0.50		mA
		Pch V <sub>DS</sub> =-2.1V, V <sub>DD</sub> =4.5V	1.0	2.0		
t <sub>PLH</sub>	Output Delay Time* <sup>Note2</sup>				100	μs
$\frac{\Delta -V_{DET}}{\Delta T_{opt}}$	Detector Threshold Temperature Coefficient	-40°C ≤ T <sub>opt</sub> ≤ 85°C		±100		ppm/°C

## ● R3111x18xA/C

T<sub>opt</sub>=25°C

Symbol	Item	Conditions	Min.	Typ.	Max.	Unit
-V <sub>DET</sub>	Detector Threshold		1.764	1.800	1.836	V
V <sub>HYS</sub>	Detector Threshold Hysteresis		0.054	0.090	0.126	V
I <sub>SS</sub>	Supply Current	V <sub>DD</sub> =1.70V V <sub>DD</sub> =3.80V		0.8 1.0	2.4 3.0	μA
V <sub>DDH</sub>	Maximum Operating Voltage				10	V
V <sub>DDL</sub>	Minimum Operating Voltage* <sup>Note1</sup>	T <sub>opt</sub> =25°C		0.55	0.70	V
		-40°C ≤ T <sub>opt</sub> ≤ 85°C		0.65	0.80	
I <sub>OUT</sub>	Output Current (Driver Output Pin)	Nch V <sub>DS</sub> =0.05V, V <sub>DD</sub> =0.70V V <sub>DS</sub> =0.50V, V <sub>DD</sub> =1.50V	0.01 1.00	0.05 2.00		mA
		Pch V <sub>DS</sub> =-2.1V, V <sub>DD</sub> =4.5V	1.0	2.0		
t <sub>PLH</sub>	Output Delay Time* <sup>Note2</sup>				100	μs
$\frac{\Delta -V_{DET}}{\Delta T_{opt}}$	Detector Threshold Temperature Coefficient	-40°C ≤ T <sub>opt</sub> ≤ 85°C		±100		ppm/°C

\*Note1: Minimum operating voltage means the value of input voltage when output voltage maintains 0.1V or less. (In the case of Nch Open Drain Output type, the output pin is pulled up with a resistance of 470kΩ to 5.0V.)

\*Note2: In the case of CMOS Output type: The time interval between the rising edge of V<sub>DD</sub> input pulse from 0.7V to (+V<sub>DET</sub>)+2.0V and output voltage level becoming to ((+V<sub>DET</sub>)+2.0V)/2.

In the case of Nch Open Drain Output type: The output pin is pulled up with a resistance of 470kΩ to 5.0V, the time interval between the rising edge of V<sub>DD</sub> input pulse from 0.7V to (+V<sub>DET</sub>)+2.0V and output voltage level becoming to 2.5V.

## ● R3111x27xA/C

Topt=25°C

Symbol	Item	Conditions	Min.	Typ.	Max.	Unit
-V <sub>DET</sub>	Detector Threshold		2.646	2.700	2.754	V
V <sub>HYS</sub>	Detector Threshold Hysteresis		0.081	0.135	0.189	V
I <sub>SS</sub>	Supply Current	V <sub>DD</sub> =2.60V V <sub>DD</sub> =4.70V		0.9 1.1	2.7 3.3	μA
V <sub>DDH</sub>	Maximum Operating Voltage				10	V
V <sub>DDL</sub>	Minimum Operating Voltage*Note1	Topt=25°C		0.55	0.70	V
		-40°C ≤ Topt ≤ 85°C		0.65	0.80	
I <sub>OUT</sub>	Output Current (Driver Output Pin)	Nch V <sub>DS</sub> =0.05V, V <sub>DD</sub> =0.70V V <sub>DS</sub> =0.50V, V <sub>DD</sub> =1.50V	0.01 1.00	0.05 2.00		mA
		Pch V <sub>DS</sub> =-2.1V, V <sub>DD</sub> =4.5V	1.0	2.0		
t <sub>PLH</sub>	Output Delay Time*Note2				100	μs
$\frac{\Delta-V_{DET}}{\Delta T_{opt}}$	Detector Threshold Temperature Coefficient	-40°C ≤ Topt ≤ 85°C		±100		ppm/°C

## ● R3111x36xA/C

Topt=25°C

Symbol	Item	Conditions	Min.	Typ.	Max.	Unit
-V <sub>DET</sub>	Detector Threshold		3.528	3.600	3.672	V
V <sub>HYS</sub>	Detector Threshold Hysteresis		0.108	0.180	0.252	V
I <sub>SS</sub>	Supply Current	V <sub>DD</sub> = 3.47V V <sub>DD</sub> = 5.60V		1.0 1.2	3.0 3.6	μA
V <sub>DDH</sub>	Maximum Operating Voltage				10	V
V <sub>DDL</sub>	Minimum Operating Voltage*Note1	Topt=25°C		0.55	0.70	V
		-40°C ≤ Topt ≤ 85°C		0.65	0.80	
I <sub>OUT</sub>	Output Current (Driver Output Pin)	Nch V <sub>DS</sub> =0.05V, V <sub>DD</sub> =0.70V V <sub>DS</sub> =0.50V, V <sub>DD</sub> =1.50V	0.01 1.00	0.05 2.00		mA
		Pch V <sub>DS</sub> =-2.1V, V <sub>DD</sub> =4.5V	1.0	2.0		
t <sub>PLH</sub>	Output Delay Time*Note2				100	μs
$\frac{\Delta-V_{DET}}{\Delta T_{opt}}$	Detector Threshold Temperature Coefficient	-40°C ≤ Topt ≤ 85°C		±100		ppm/°C

\*Note1: Minimum operating voltage means the value of input voltage when output voltage maintains 0.1V or less. (In the case of Nch Open Drain Output type, the output pin is pulled up with a resistance of 470kΩ to 5.0V.)

\*Note2: In the case of CMOS Output type: The time interval between the rising edge of V<sub>DD</sub> input pulse from 0.7V to (+V<sub>DET</sub>)+2.0V and output voltage level becoming to ((+V<sub>DET</sub>)+2.0V)/2.

In the case of Nch Open Drain Output type: The output pin is pulled up with a resistance of 470kΩ to 5.0V, the time interval between the rising edge of V<sub>DD</sub> input pulse from 0.7V to (+V<sub>DET</sub>)+2.0V and output voltage level becoming to 2.5V.

## R3111x

### • R3111x45xA/C

Topt=25°C

Symbol	Item	Conditions	Min.	Typ.	Max.	Unit
-V <sub>DET</sub>	Detector Threshold		4.410	4.500	4.590	V
V <sub>HYS</sub>	Detector Threshold Hysteresis		0.135	0.225	0.315	V
I <sub>SS</sub>	Supply Current	V <sub>DD</sub> =4.34V V <sub>DD</sub> =6.50V		1.1 1.3	3.3 3.9	μA
V <sub>DDH</sub>	Maximum Operating Voltage				10	V
V <sub>DDL</sub>	Minimum Operating Voltage*Note1	Topt=25°C		0.55	0.70	V
		-40°C ≤ Topt ≤ 85°C		0.65	0.80	
I <sub>OUT</sub>	Output Current (Driver Output Pin)	Nch V <sub>DS</sub> =0.05V, V <sub>DD</sub> =0.70V V <sub>DS</sub> =0.50V, V <sub>DD</sub> =1.50V	0.01 1.00	0.05 2.00		mA
		Pch V <sub>DS</sub> =-2.1V, V <sub>DD</sub> =8.0V	1.5	3.0		
t <sub>PLH</sub>	Output Delay Time*Note2				100	μs
Δ-V <sub>DET</sub> / ΔTopt	Detector Threshold Temperature Coefficient	-40°C ≤ Topt ≤ 85°C		±100		ppm/°C

### • R3111x54xA/C

Topt=25°C

Symbol	Item	Conditions	Min.	Typ.	Max.	Unit
-V <sub>DET</sub>	Detector Threshold		5.292	5.400	5.508	V
V <sub>HYS</sub>	Detector Threshold Hysteresis		0.162	0.270	0.378	V
I <sub>SS</sub>	Supply Current	V <sub>DD</sub> =5.20V V <sub>DD</sub> =7.40V		1.2 1.4	3.6 4.2	μA
V <sub>DDH</sub>	Maximum Operating Voltage				10	V
V <sub>DDL</sub>	Minimum Operating Voltage*Note1	Topt=25°C		0.55	0.70	V
		-40°C ≤ Topt ≤ 85°C		0.65	0.80	
I <sub>OUT</sub>	Output Current (Driver Output Pin)	Nch V <sub>DS</sub> =0.05V, V <sub>DD</sub> =0.70V V <sub>DS</sub> =0.50V, V <sub>DD</sub> =1.50V	0.01 1.00	0.05 2.00		mA
		Pch V <sub>DS</sub> =-2.1V, V <sub>DD</sub> =8.0V	1.5	3.0		
t <sub>PLH</sub>	Output Delay Time*Note2				100	μs
Δ-V <sub>DET</sub> / ΔTopt	Detector Threshold Temperature Coefficient	-40°C ≤ Topt ≤ 85°C		±100		ppm/°C

\*Note1: Minimum operating voltage means the value of input voltage when output voltage maintains 0.1V or less. (In the case of Nch Open Drain Output type, the output pin is pulled up with a resistance of 470kΩ to 5.0V.)

\*Note2: In the case of CMOS Output type: The time interval between the rising edge of V<sub>DD</sub> input pulse from 0.7V to (+V<sub>DET</sub>)+2.0V and output voltage level becoming to ((+V<sub>DET</sub>)+2.0V)/2.

In the case of Nch Open Drain Output type: The output pin is pulled up with a resistance of 470kΩ to 5.0V, the time interval between the rising edge of V<sub>DD</sub> input pulse from 0.7V to (+V<sub>DET</sub>)+2.0V and output voltage level becoming to 2.5V.



## ● R3111Q231B

T<sub>opt</sub>=25°C

Symbol	Item	Conditions	Min.	Typ.	Max.	Unit
-V <sub>DET</sub>	Detector Threshold		2.254	2.300	2.346	V
V <sub>HYS</sub>	Detector Threshold Hysteresis		0.069	0.115	0.161	V
I <sub>SS</sub>	Supply Current	V <sub>DD</sub> =2.2V V <sub>DD</sub> =4.3V		0.9 1.1	2.7 3.3	μA
V <sub>DDH</sub>	Maximum Operating Voltage				10	V
V <sub>DDL</sub>	Minimum Operating Voltage* <sup>Note1</sup>	T <sub>opt</sub> =25°C		0.55	0.70	V
		-40°C ≤ T <sub>opt</sub> ≤ 85°C		0.65	0.80	
I <sub>OUT</sub>	Output Current (Driver Output Pin)	Nch V <sub>DS</sub> =0.50V, V <sub>DD</sub> =3.0V	2.5			mA
t <sub>PLH</sub>	Output Delay Time* <sup>Note2</sup>				100	μs
Δ-V <sub>DET</sub> / ΔT <sub>opt</sub>	Detector Threshold Temperature Coefficient	-40°C ≤ T <sub>opt</sub> ≤ 85°C		±100		ppm/°C

## ● R3111Q441B

T<sub>opt</sub>=25°C

Symbol	Item	Conditions	Min.	Typ.	Max.	Unit
-V <sub>DET</sub>	Detector Threshold		4.312	4.400	4.488	V
V <sub>HYS</sub>	Detector Threshold Hysteresis		0.132	0.220	0.308	V
I <sub>SS</sub>	Supply Current	V <sub>DD</sub> =4.24V V <sub>DD</sub> =6.4V		1.1 1.3	3.3 3.9	μA
V <sub>DDH</sub>	Maximum Operating Voltage				10	V
V <sub>DDL</sub>	Minimum Operating Voltage* <sup>Note1</sup>	T <sub>opt</sub> =25°C		0.55	0.70	V
		-40°C ≤ T <sub>opt</sub> ≤ 85°C		0.65	0.80	
I <sub>OUT</sub>	Output Current (Driver Output Pin)	Nch V <sub>DS</sub> =0.50V, V <sub>DD</sub> =5.5V	2.5			mA
t <sub>PLH</sub>	Output Delay Time* <sup>Note2</sup>				100	μs
Δ-V <sub>DET</sub> / ΔT <sub>opt</sub>	Detector Threshold Temperature Coefficient	-40°C ≤ T <sub>opt</sub> ≤ 85°C		±100		ppm/°C

\*Note1: Minimum operating voltage means the value of input voltage when output voltage maintains 0.1V or less. (In the case of Nch Open Drain Output type, the output pin is pulled up with a resistance of 470kΩ to 5.0V.)

\*Note2: In the case of CMOS Output type: The time interval between the rising edge of V<sub>DD</sub> input pulse from 0.7V to (+V<sub>DET</sub>)+2.0V and output voltage level becoming to ((+V<sub>DET</sub>)+2.0V)/2.

In the case of Nch Open Drain Output type: The output pin is pulled up with a resistance of 470kΩ to 5.0V, the time interval between the rising edge of V<sub>DD</sub> input pulse from 0.7V to (+V<sub>DET</sub>)+2.0V and output voltage level becoming to 2.5V.

## TIMING CHART

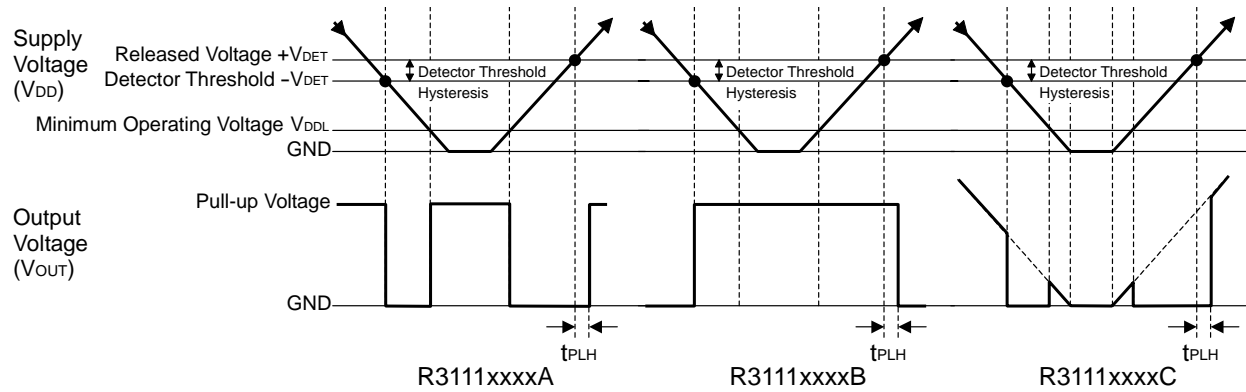

## DEFINITION OF OUTPUT DELAY TIME

Output Delay Time ( $t_{PLH}$ ) is defined as follows:

1. In the case of Nch Open Drain Output:(R3111xxxxA/B)

Under the condition of the output pin (OUT) is pulled up through a resistor of 470k $\Omega$  to 5V, the time interval between the rising edge of  $V_{DD}$  pulse from 0.7V to  $(+V_{DET})+2.0V$  and becoming of the output voltage to 2.5V.

2. In the case of CMOS Output:(R3111xxxxC)

The time interval between the rising edge of  $V_{DD}$  pulse from 0.7V to  $(+V_{DET})+2.0V$  and becoming of the output voltage to  $((+V_{DET})+2.0V)/2$ .

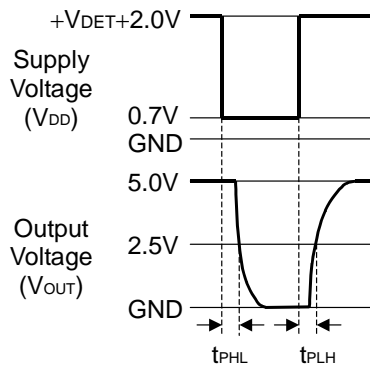

**Nch Open Drain Output  
(R3111xxxxA)**

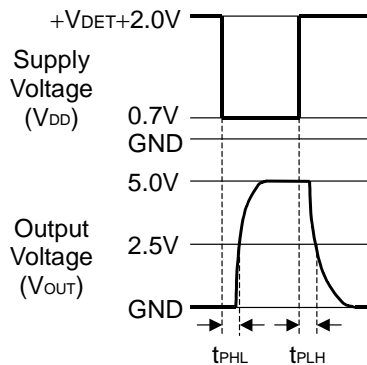

**Nch Open Drain Output  
(R3111xxxxB)**

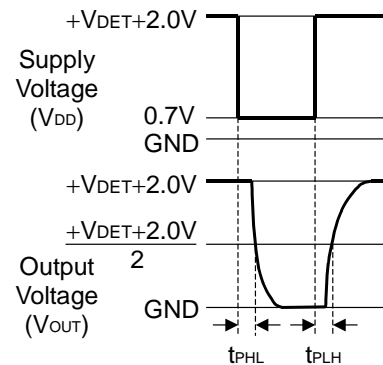

**CMOS Output  
(R3111xxxxC)**



## ELECTRICAL CHARACTERISTICS BY DETECTOR THRESHOLD

## ● R3111x09x to R3111x60x

Part Number	Detector Threshold			Detector Threshold Hysteresis			Supply Current 1			Supply Current 2		
	-VDET[V]			VHYS[V]			ISS1[μA]			ISS2[μA]		
	Min.	Typ.	Max.	Min.	Typ.	Max.	Condition	Typ.	Max.	Condition	Typ.	Max.
R3111x09xx	0.882	0.900	0.918	0.027	0.045	0.063	VDD= (-VDET) -0.10V	0.8	2.4	VDD= (-VDET) +2.0V	0.9	2.7
R3111x10xx	0.980	1.000	1.020	0.030	0.050	0.070					1.0	3.0
R3111x11xx	1.078	1.100	1.122	0.033	0.055	0.077						
R3111x12xx	1.176	1.200	1.224	0.036	0.060	0.084						
R3111x13xx	1.274	1.300	1.326	0.039	0.065	0.091						
R3111x14xx	1.372	1.400	1.428	0.042	0.070	0.098						
R3111x15xx	1.470	1.500	1.530	0.045	0.075	0.105						
R3111x16xx	1.568	1.600	1.632	0.048	0.080	0.112						
R3111x17xx	1.666	1.700	1.734	0.051	0.085	0.119						
R3111x18xx	1.764	1.800	1.836	0.054	0.090	0.126						
R3111x19xx	1.862	1.900	1.938	0.057	0.095	0.133						
R3111x20xx	1.960	2.000	2.040	0.060	0.100	0.140						
R3111x21xx	2.058	2.100	2.142	0.063	0.105	0.147						
R3111x22xx	2.156	2.200	2.244	0.066	0.110	0.154						
R3111x23xx	2.254	2.300	2.346	0.069	0.115	0.161						
R3111x24xx	2.352	2.400	2.448	0.072	0.120	0.168						
R3111x25xx	2.450	2.500	2.550	0.075	0.125	0.175						
R3111x26xx	2.548	2.600	2.652	0.078	0.130	0.182						
R3111x27xx	2.646	2.700	2.754	0.081	0.135	0.189						
R3111x28xx	2.744	2.800	2.856	0.084	0.140	0.196						
R3111x29xx	2.842	2.900	2.958	0.087	0.145	0.203						
R3111x30xx	2.940	3.000	3.060	0.090	0.150	0.210						
R3111x31xx	3.038	3.100	3.162	0.093	0.155	0.217						
R3111x32xx	3.136	3.200	3.264	0.096	0.160	0.224						
R3111x33xx	3.234	3.300	3.366	0.099	0.165	0.231						
R3111x34xx	3.332	3.400	3.468	0.102	0.170	0.238						
R3111x35xx	3.430	3.500	3.570	0.105	0.175	0.245						
R3111x36xx	3.528	3.600	3.672	0.108	0.180	0.252						
R3111x37xx	3.626	3.700	3.774	0.111	0.185	0.259						
R3111x38xx	3.724	3.800	3.876	0.114	0.190	0.266						
R3111x39xx	3.822	3.900	3.978	0.117	0.195	0.273						
R3111x40xx	3.920	4.000	4.080	0.120	0.200	0.280						
R3111x41xx	4.018	4.100	4.182	0.123	0.205	0.287						
R3111x42xx	4.116	4.200	4.284	0.126	0.210	0.294						
R3111x43xx	4.214	4.300	4.386	0.129	0.215	0.301						
R3111x44xx	4.312	4.400	4.488	0.132	0.220	0.308						
R3111x45xx	4.410	4.500	4.590	0.135	0.225	0.315						
R3111x46xx	4.508	4.600	4.692	0.138	0.230	0.322						
R3111x47xx	4.606	4.700	4.794	0.141	0.235	0.329						
R3111x48xx	4.704	4.800	4.896	0.144	0.240	0.336						
R3111x49xx	4.802	4.900	4.998	0.147	0.245	0.343						
R3111x50xx	4.900	5.000	5.100	0.150	0.250	0.350						
R3111x51xx	4.998	5.100	5.202	0.153	0.255	0.357						
R3111x52xx	5.096	5.200	5.304	0.156	0.260	0.364						
R3111x53xx	5.194	5.300	5.406	0.159	0.265	0.371						
R3111x54xx	5.292	5.400	5.508	0.162	0.270	0.378						
R3111x55xx	5.390	5.500	5.610	0.165	0.275	0.385						
R3111x56xx	5.488	5.600	5.712	0.168	0.280	0.392						
R3111x57xx	5.586	5.700	5.814	0.171	0.285	0.399						
R3111x58xx	5.684	5.800	5.916	0.174	0.290	0.406						
R3111x59xx	5.782	5.900	6.018	0.177	0.295	0.413						
R3111x60xx	5.880	6.000	6.120	0.180	0.300	0.420						

\*1) In the case of CMOS output type; when the voltage is forced to VDD from 0.7V to (+VDET)+2.0V, time interval between the rising edge of VDD and the reaching point at ((+VDET)+2.0V)/2. In the case of Nch open drain output type : The output pin is pulled up to 5V through 470kΩ, and when the voltage is forced to VDD from 0.7V to (+VDET)+2.0V, time interval between the rising edge of VDD and the reaching point at ((+VDET)+2.0V)/2.

\*2) VDD value when Output Voltage is equal or less than 0.1V. In the case of Nch open drain output type, the output pin is pulled up to 5V through 470kΩ resistor.

Condition 1: Topt=25°C

Condition 2: -40°C ≤ Topt ≤ 85°C

Output Current 1 *3			Output Current 2 *3			Output Delay Time	Minimum Operating Voltage		Detector Threshold Temperature Coefficient	
I <sub>OUT1</sub> [mA]			I <sub>OUT2</sub> [mA]			t <sub>PLH</sub> [μs]	V <sub>DDL</sub> [V]		Δ-V <sub>DET</sub> /ΔT <sub>opt</sub> [ppm/°C]	
Condition	Min.	Typ.	Condition	Min.	Typ.	Max.	Typ.	Max.	Condition	Typ.
Nch V <sub>DS</sub> =0.05V V <sub>DD</sub> =0.7V	0.01	0.05	V <sub>DD</sub> = 0.85V	0.05	0.5	100 *1			-40°C ≤ T <sub>opt</sub> ≤ 85°C	±100
			V <sub>DD</sub> = 1.0V	0.2	1.0					
			V <sub>DD</sub> = 1.5V	1.0	2.0					
							*2	*2		
							Condition 1	Condition 1		
							0.55	0.70		
							Condition 2	Condition 2		
							0.65	0.80		

\*3) Output Current (I<sub>OUT</sub>) of R3111xxxxB has not been described. Please inquire details.

## OPERATION

### • Operation of R3111xxxxA

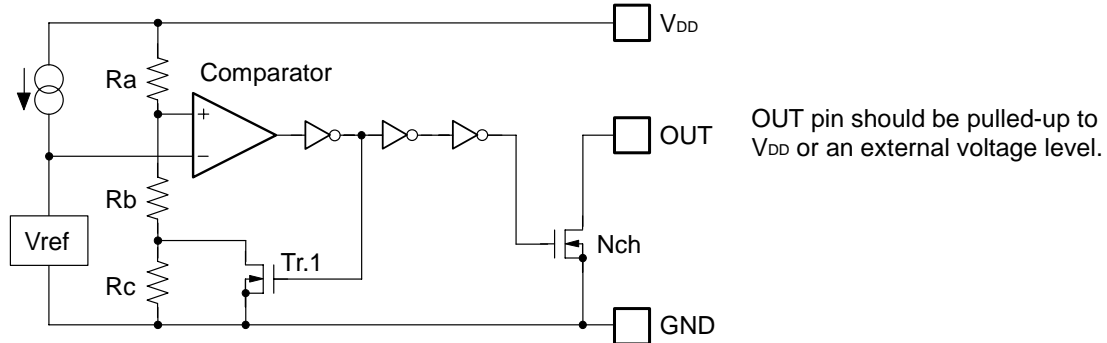

Block Diagram (R3111xxxxA)

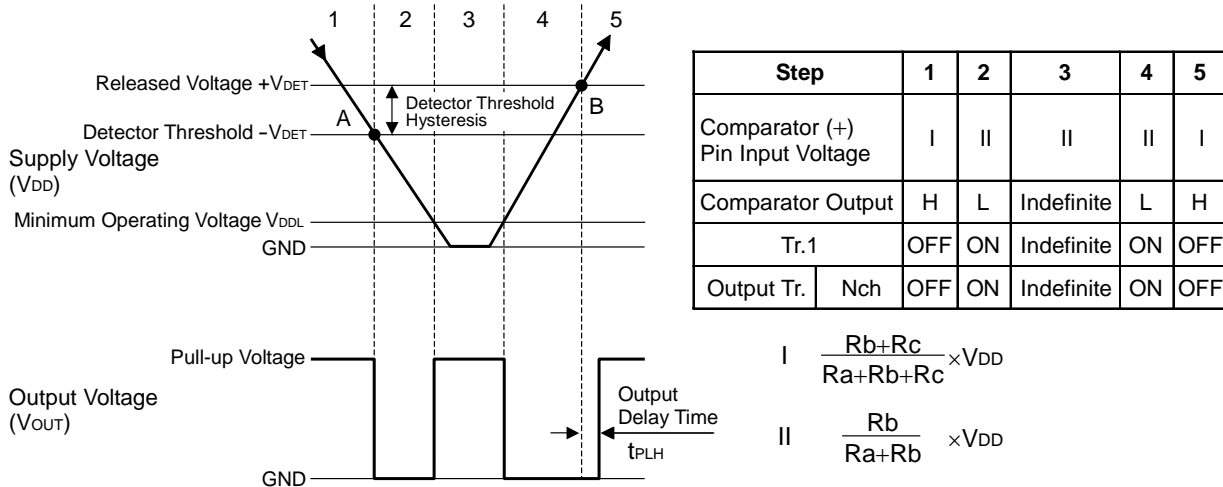

Operation Diagram

### • Explanation of operation

Step 1. The output voltage is equal to the pull-up voltage.

Step 2. At Point "A",  $V_{ref} \geq V_{DD} \times (R_b + R_c) / (R_a + R_b + R_c)$  is true, as a result, the output of comparator is reversed from "H" to "L", therefore the output voltage becomes the GND level. The voltage level of Point A means a detector threshold voltage ( $-V_{DET}$ ).

Step 3. When the supply voltage is lower than the minimum operating voltage, the operation of the output transistor becomes indefinite. The output voltage is equal to the pull-up voltage.

Step 4. The output Voltage is equal to the GND level.

Step 5. At Point "B",  $V_{ref} \leq V_{DD} \times R_b / (R_a + R_b)$  is true, as a result, the output of comparator is reversed from "L" to "H", then the output voltage is equal to the pull-up voltage. The voltage level of Point B means a released voltage ( $+V_{DET}$ ).

\*) The difference between a released voltage and a detector threshold voltage is a detector threshold hysteresis.

• Operation of R3111xxxxB

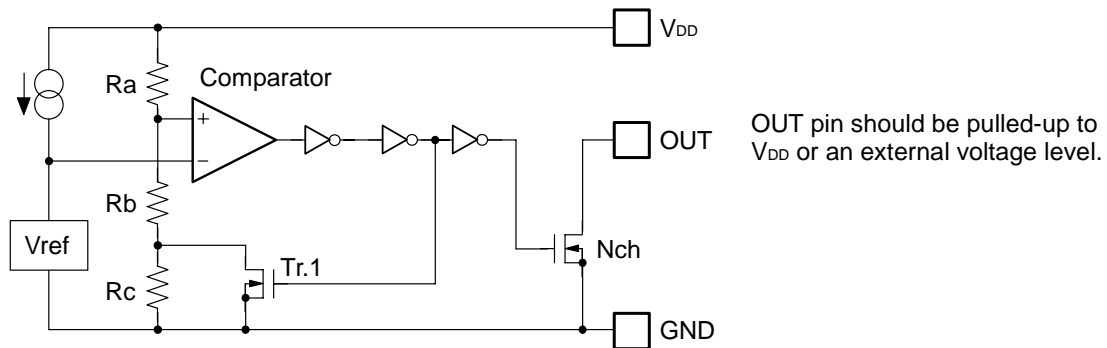

Block Diagram (R3111xxxxB)

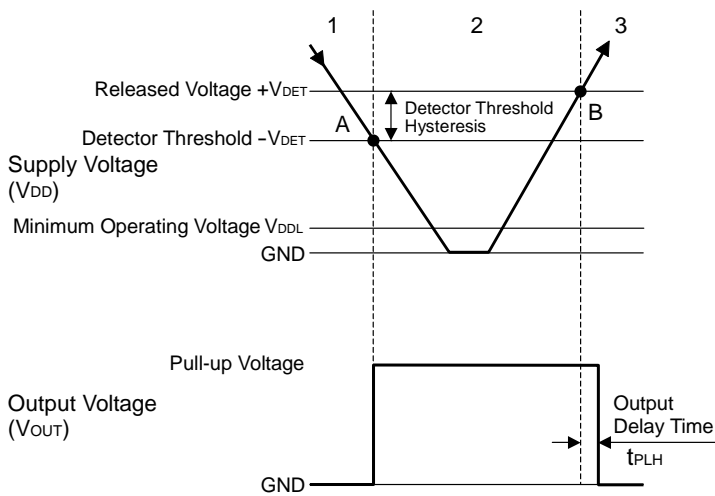

Step	1	2	3
Comparator (+) Pin Input Voltage	I	II	I
Comparator Output	L	H	L
Tr.1	OFF	ON	OFF
Output Tr. Nch	ON	OFF	ON

$$I \quad \frac{R_b+R_c}{R_a+R_b+R_c} \times V_{DD}$$

$$II \quad \frac{R_b}{R_a+R_b} \times V_{DD}$$

Operation Diagram

• Explanation of operation

Step 1. The output voltage is equal to the GND level.

Step 2. At Point "A",  $V_{ref} \geq V_{DD} \times (R_b+R_c)/(R_a+R_b+R_c)$  is true, as a result, the output of comparator is reversed from "L" to "H", therefore the output voltage becomes the pull-up voltage. The voltage level of Point A means a detector threshold voltage ( $-V_{DET}$ ).

Step 3. At Point "B",  $V_{ref} \leq V_{DD} \times R_b/(R_a+R_b)$  is true, as a result, the output of comparator is reversed from "H" to "L", then the output voltage is equal to the GND level. The voltage level of Point B means a released voltage ( $+V_{DET}$ ).

\*) The difference between a released voltage and a detector threshold voltage is a detector threshold hysteresis.

• Operation of R3111xxxxC

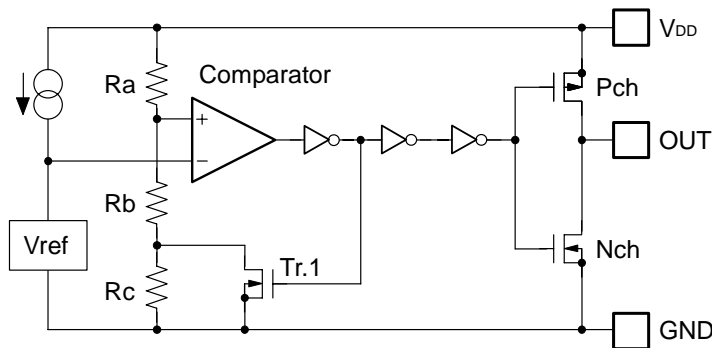

Block Diagram (R3111xxxxC)

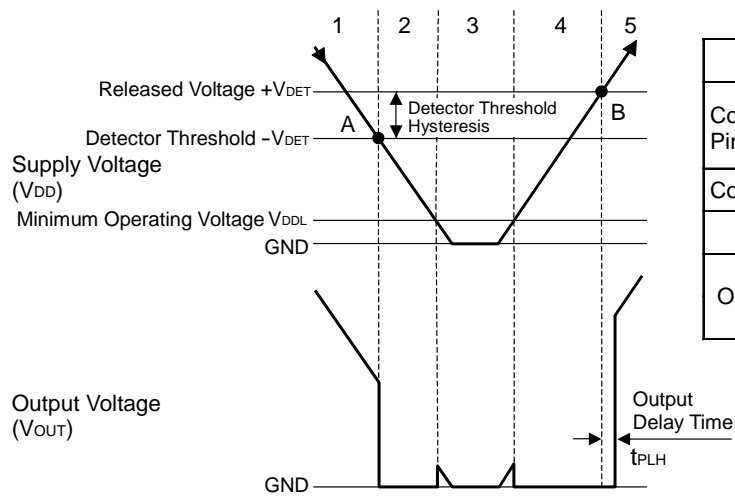

Step	1	2	3	4	5
Comparator (-) Pin Input Voltage	I	II	II	II	I
Comparator Output	H	L	Indefinite	L	H
Tr.1	OFF	ON	Indefinite	ON	OFF
Output Tr.	Pch	ON	OFF	Indefinite	OFF
	Nch	OFF	ON	Indefinite	ON

$$I \quad \frac{Rb+Rc}{Ra+Rb+Rc} \times V_{DD}$$

$$II \quad \frac{Rb}{Ra+Rb} \times V_{DD}$$

Operation Diagram

• Explanation of operation

Step 1. The output voltage is equal to the supply voltage ( $V_{DD}$ ).

Step 2. At Point "A",  $V_{ref} \geq V_{DD} \times (Rb+Rc) / (Ra+Rb+Rc)$  is true, as a result, the output of comparator is reversed from "H" to "L", therefore the output voltage becomes the GND level. The voltage level of Point A means a detector threshold voltage ( $-V_{DET}$ ).

Step 3. When the supply voltage is lower than the minimum operating voltage, the operation of the output transistor becomes indefinite.

Step 4. The output Voltage is equal to the GND level.

Step 5. At Point "B",  $V_{ref} \leq V_{DD} \times Rb / (Ra+Rb)$  is true, as a result, the output of comparator is reversed from "L" to "H", then the output voltage is equal to the supply voltage ( $V_{DD}$ ). The voltage level of Point B means a released voltage ( $+V_{DET}$ ).

\*) The difference between a released voltage and a detector threshold voltage is a detector threshold hysteresis.



## TEST CIRCUITS

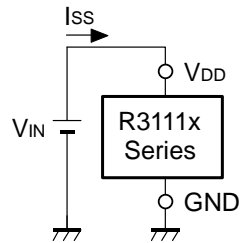

**Supply Current Test Circuit**

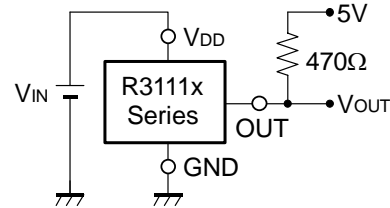

**Detector Threshold Test Circuit**  
(Pull-up circuit is not necessary for CMOS Output type.)

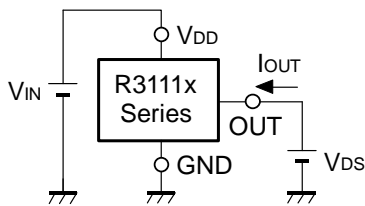

**Nch Driver Output Current Test Circuit**

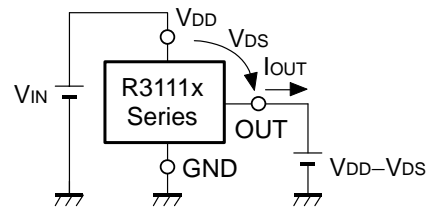

**Pch Driver Output Current Test Circuit**  
\*Apply to CMOS Output type only

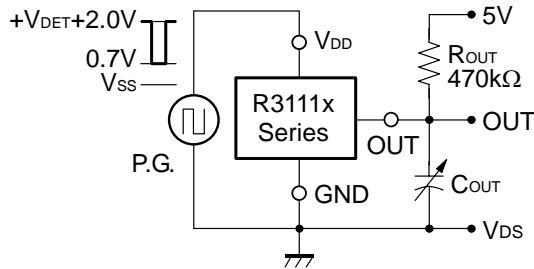

**Output Delay Time Test Circuit (1)**  
(Pull-up circuit is not necessary for CMOS Output type.)

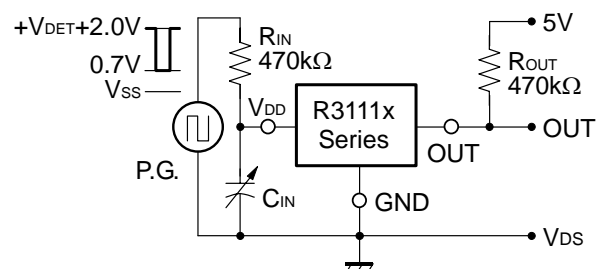

**Output Delay Time Test Circuit (2)**

## TYPICAL CHARACTERISTICS

### 1) Supply Current vs. Input Voltage

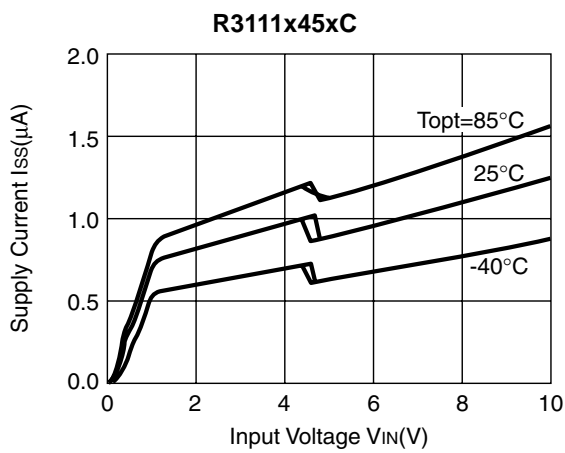
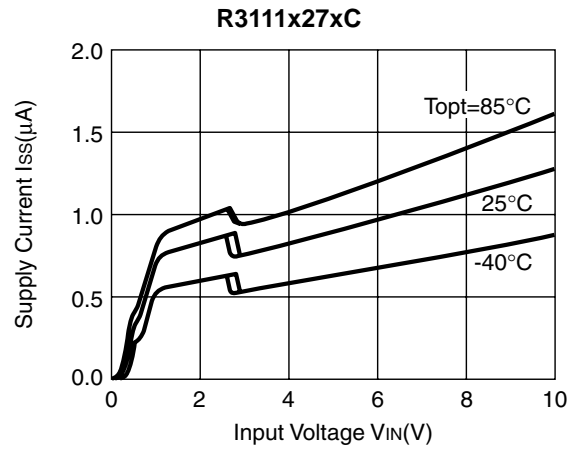
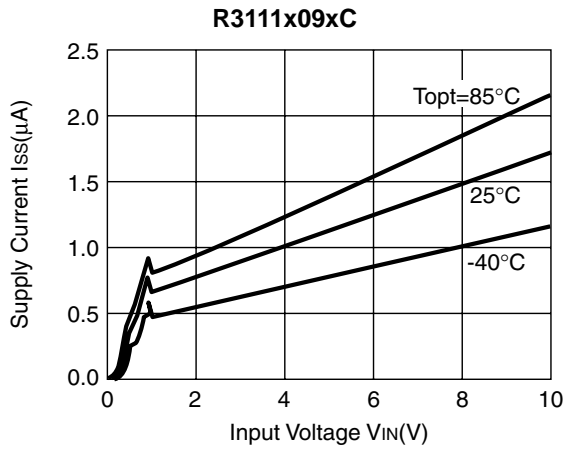

### 2) Detector Threshold Hysteresis vs. Temperature

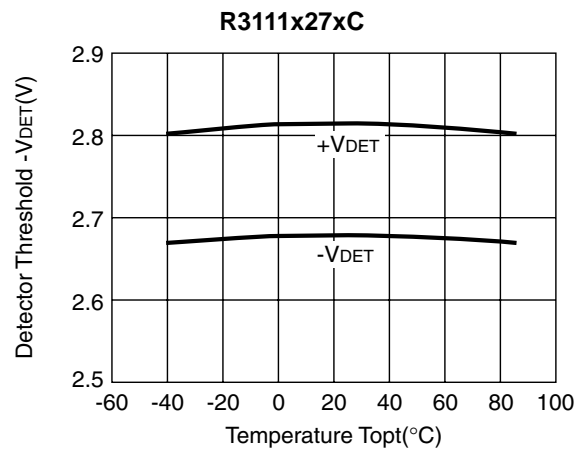
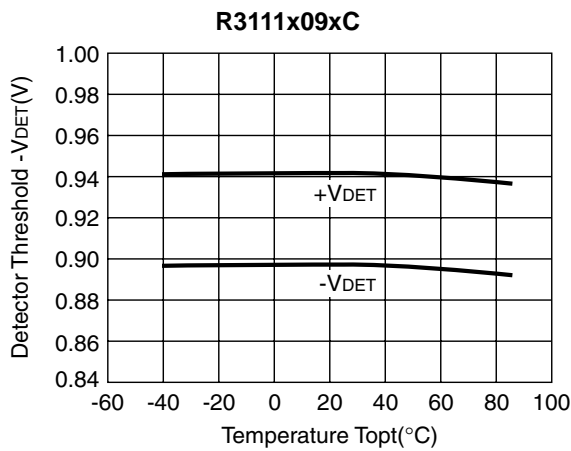

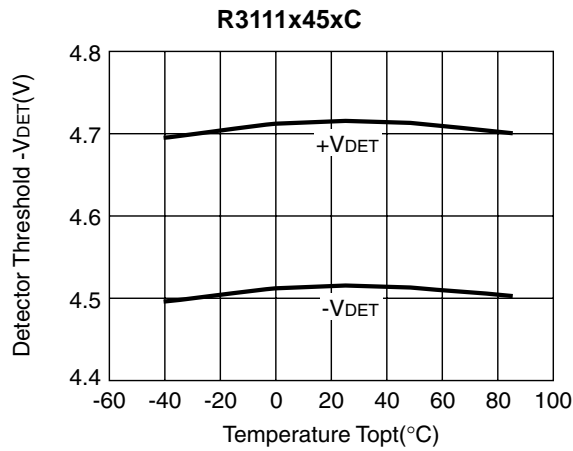

### 3) Output Voltage vs. Input Voltage

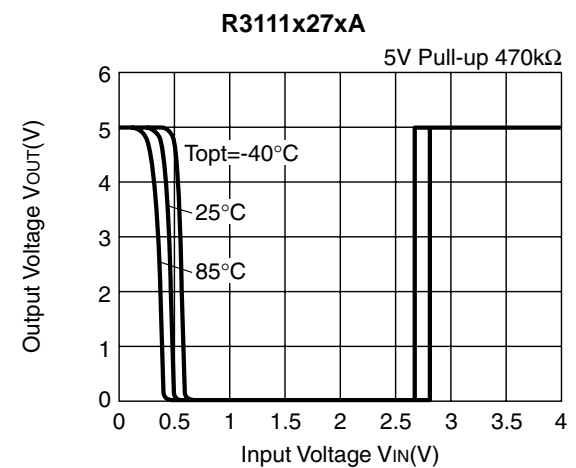
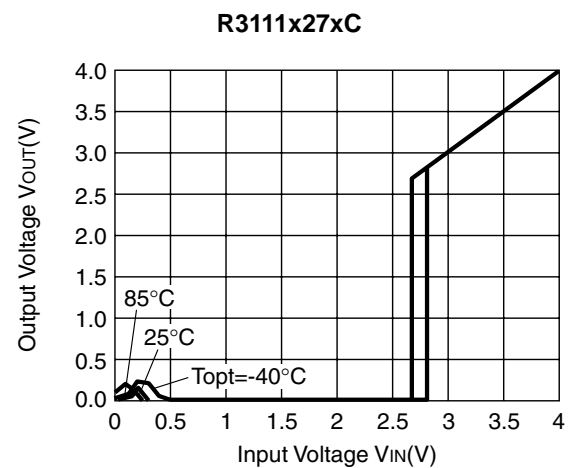
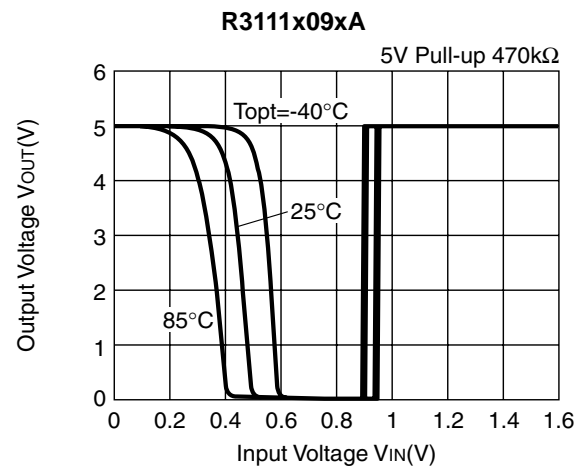
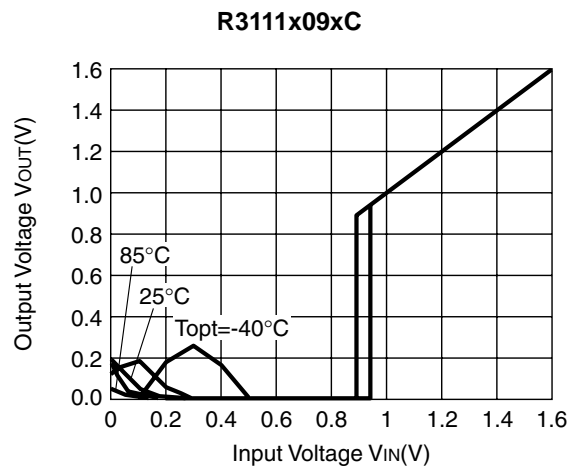

# R3111x

**R3111x45xC**

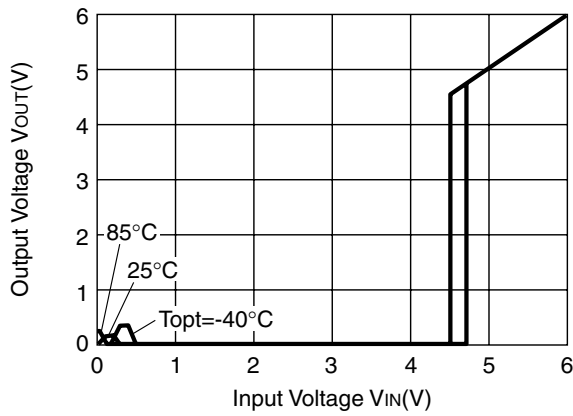

**R3111x45xA**

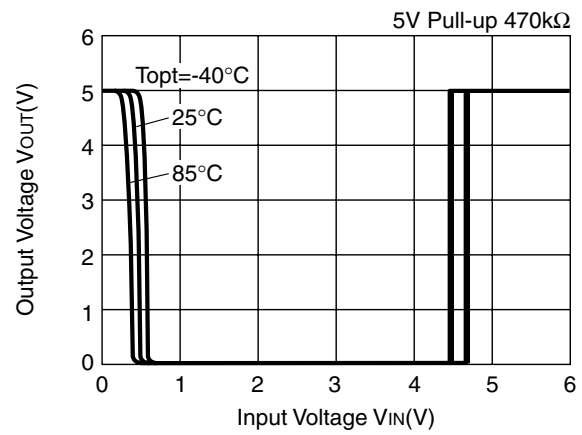

## 4) Nch Driver Output Current vs. $V_{DS}$

**R3111x09xC**

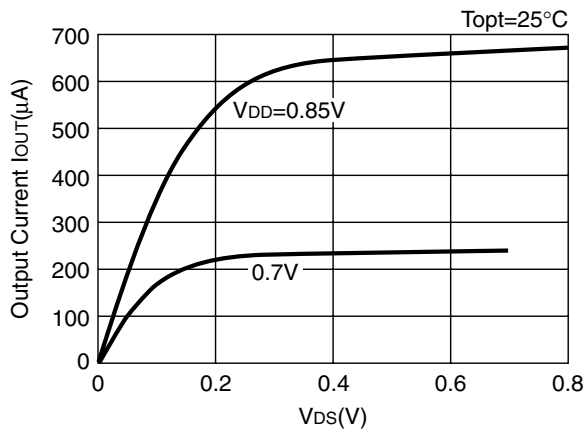

**R3111x09xC**

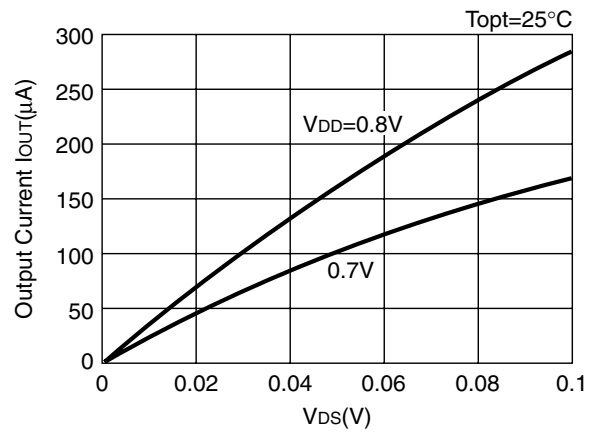

**R3111x27xC**

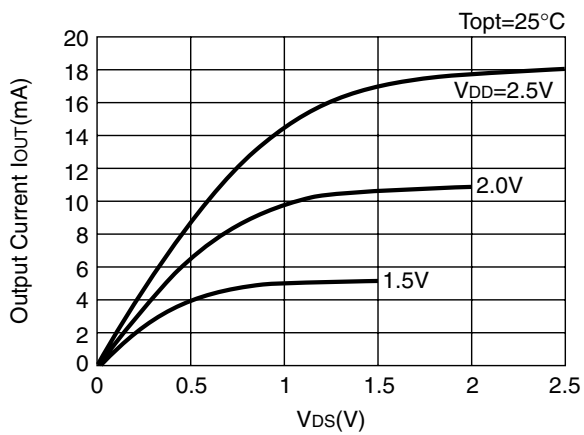

**R3111x27xC**

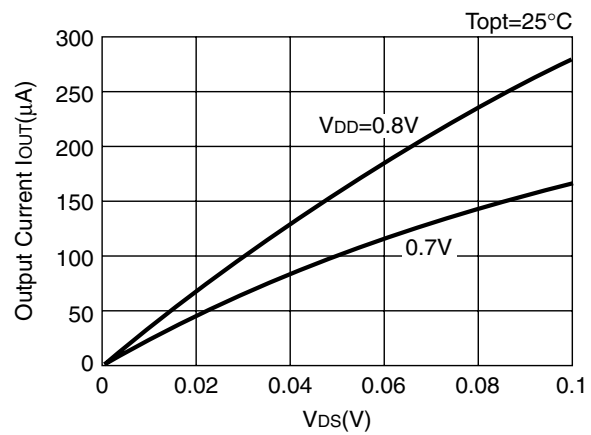

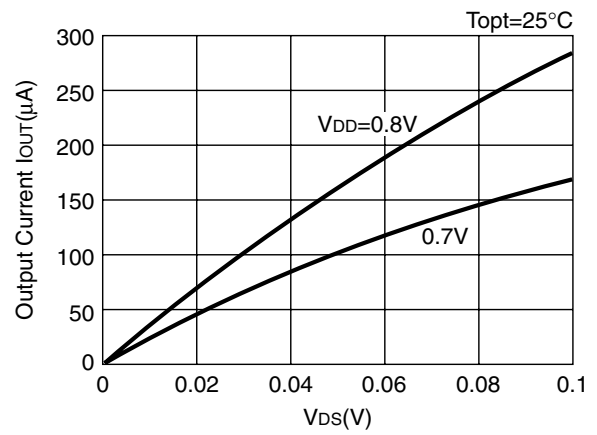
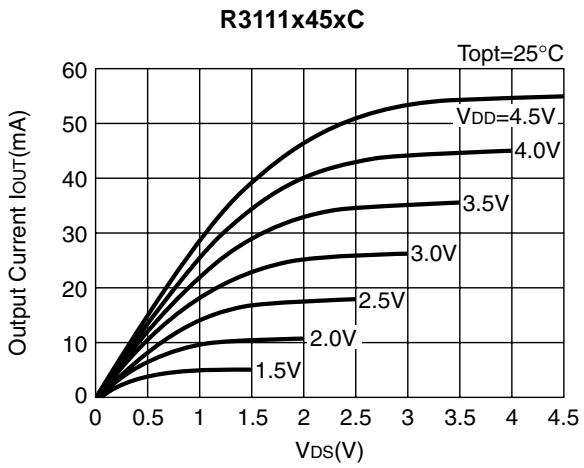

5) Nch Driver Output Current vs. Input Voltage

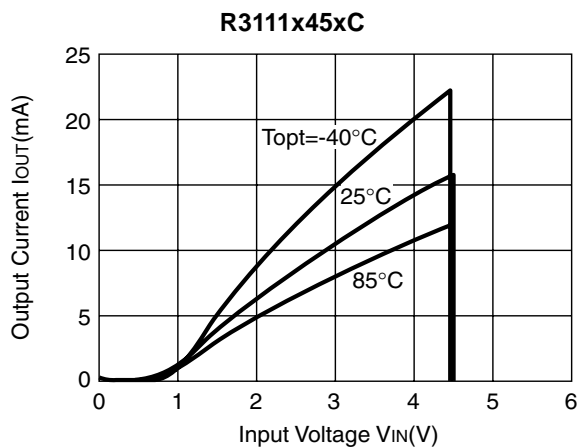
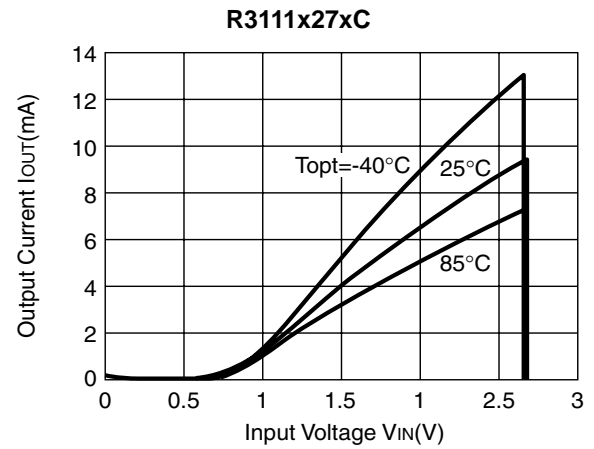
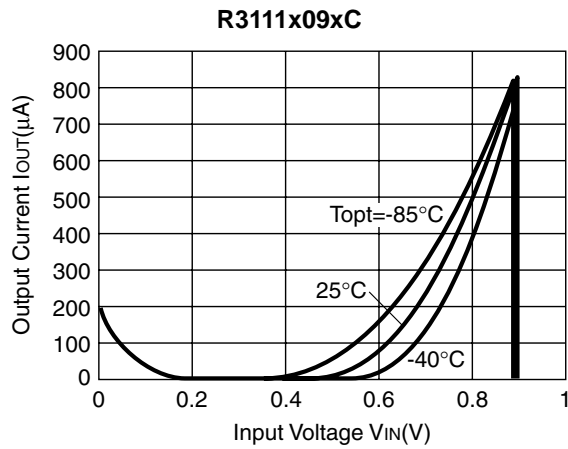

6) Pch Driver Output Current vs. Input Voltage

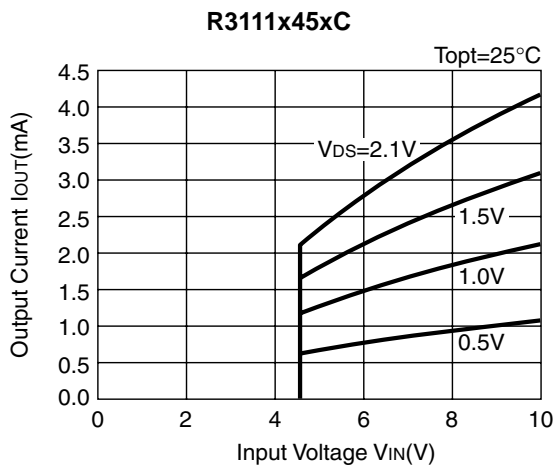
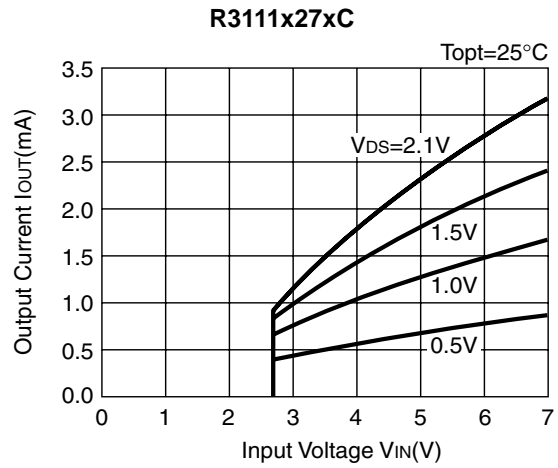
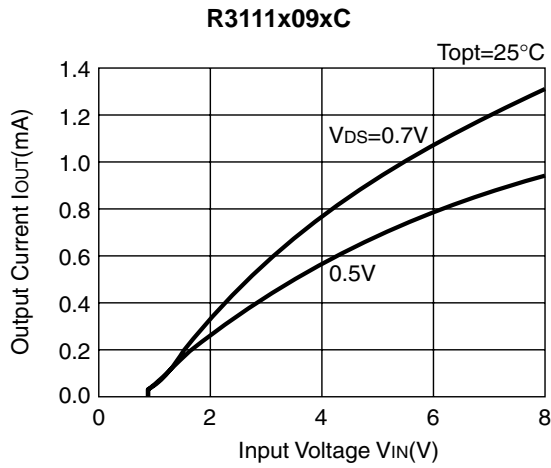

7) Output Delay Time vs. Load Capacitance (Top<sub>t</sub>=25°C)

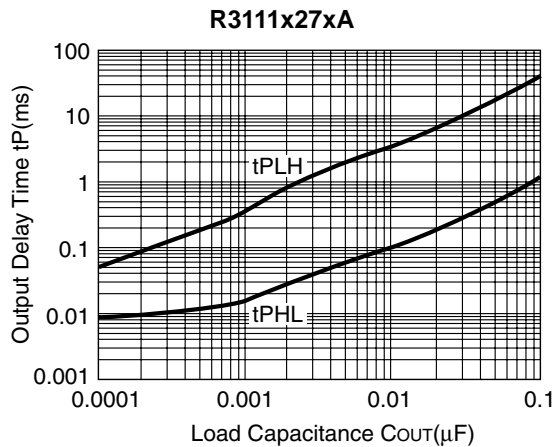
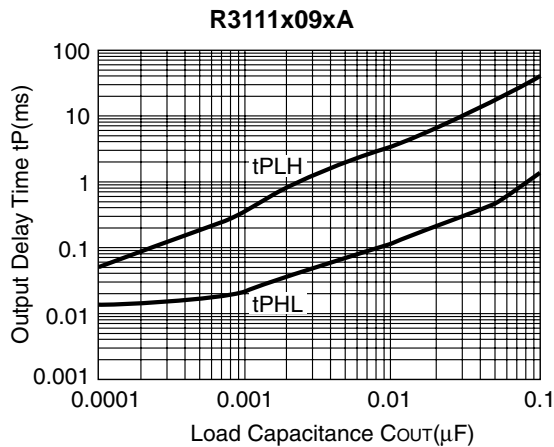

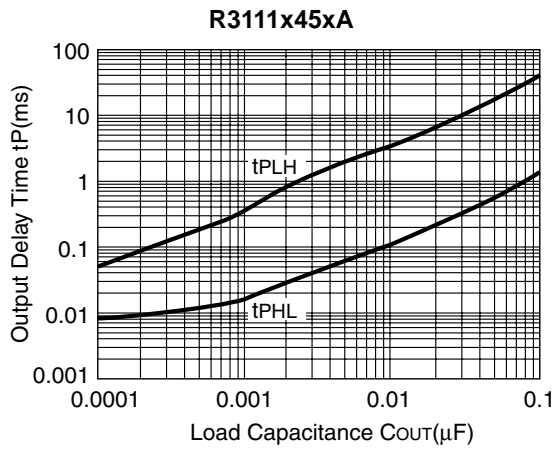

### 8) Output Delay Time vs. Input Pin Capacitance

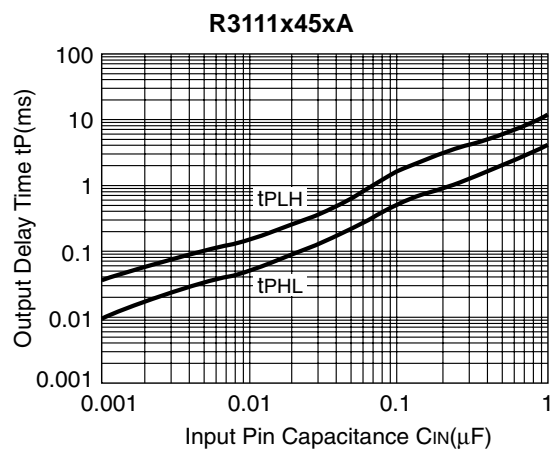
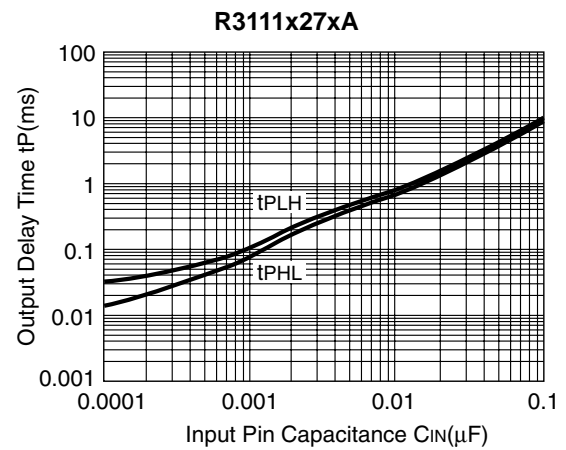
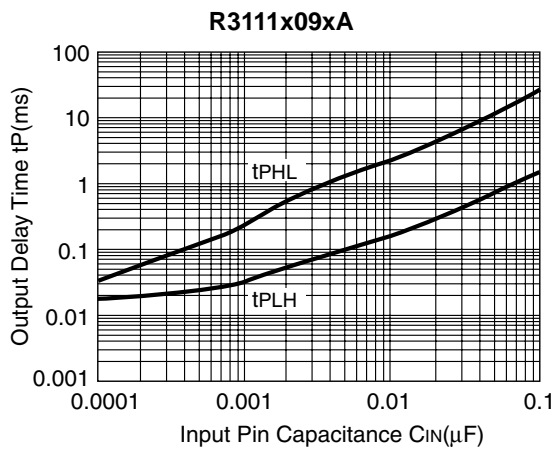

## TYPICAL APPLICATION

### • R3111xxxxA CPU Reset Circuit (Nch Open Drain Output)

Case 1. Input Voltage to R3111xxxxA is equal to Input Voltage to CPU

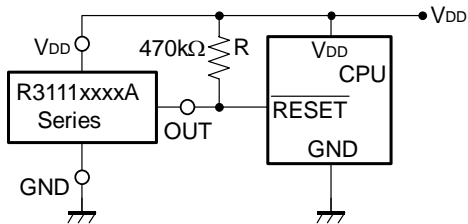

Case 2. Input Voltage to R3111xxxxA is unequal to Input Voltage to CPU

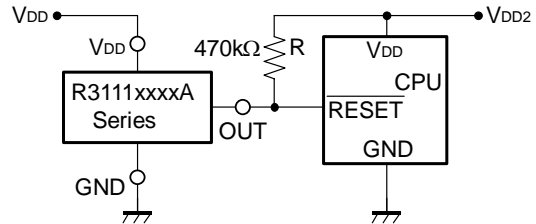

### • R3111xxxxC CPU Reset Circuit (CMOS Output)

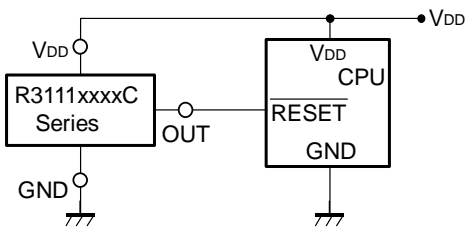

### • R3111xxxxA Output Delay Time Circuit 1 (Nch Open Drain Output)

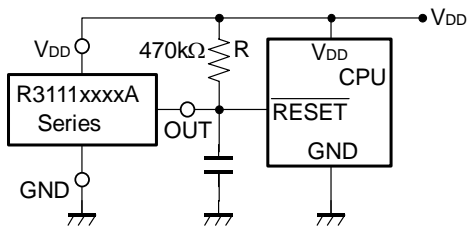

### • R3111xxxxA Output Delay Time Circuit 2 (Nch Open Drain Output)

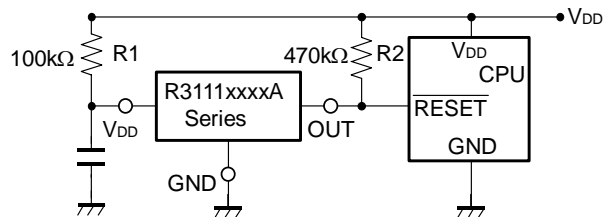

### • Memory Back-up Circuit

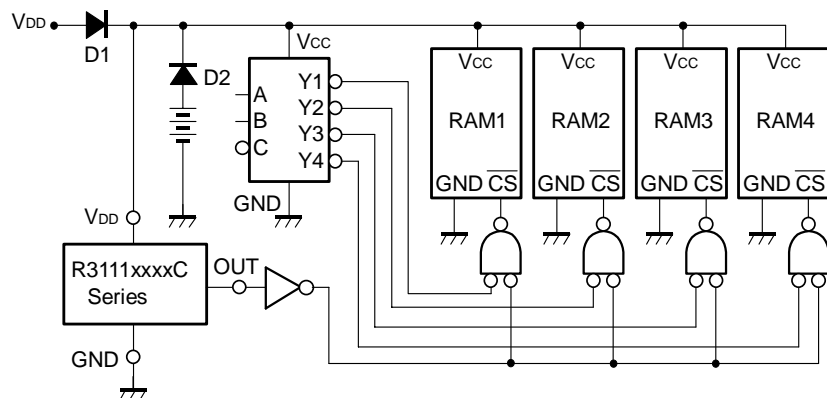



- **Voltage level Indicator Circuit (lighted when the power runs out)**  
(Nch Open Drain Output)

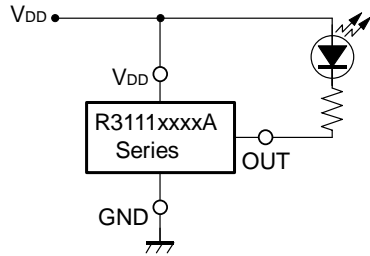

- **Detector Threshold Adjustable Circuit**  
(Nch Open Drain Output)

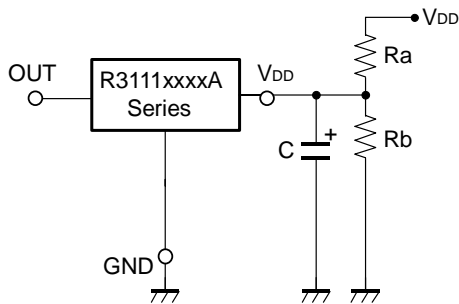

Adjusted Detector Threshold  
 $= (-V_{DET}) \times (R_a + R_b) / R_b$

Hysteresis Voltage  
 $= (V_{HYS}) \times (R_a + R_b) / R_b$

\*) If the value of Ra is set excessively large, voltage drop may occur caused by the supply current of IC itself, and detector threshold may vary.

- **Window Comparator Circuit**  
(Nch Open Drain Output)

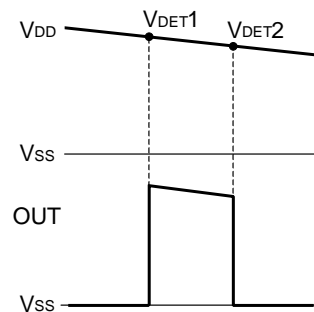
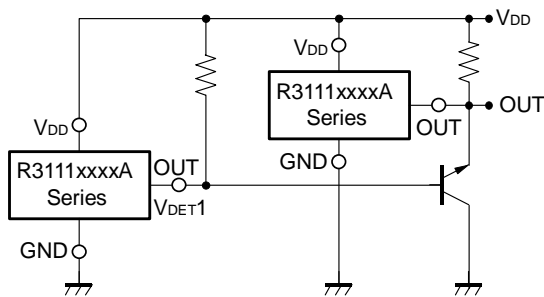

- **Over-charge Preventing Circuit**

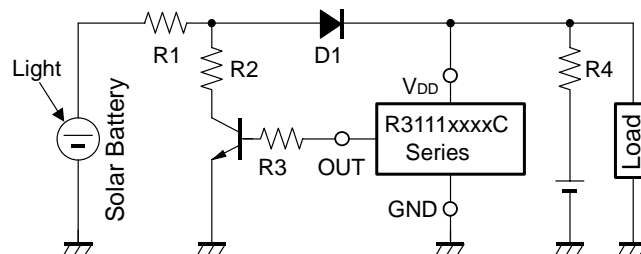

## TECHNICAL NOTES

When R3111xxxxA/B (Nch Open Drain Output Type) is used in Figure A or Figure B, if impedance of Voltage Supply pin,  $V_{DD}$  and  $V_{DD}$  of this IC is large, detector threshold level would shift by voltage dropdown caused by the consumption current of the IC itself. Released voltage may also shift and delay time for start-up might be generated by this usage.

When R3111xxxxC (CMOS Output Type) is used in Figure A or Figure B, Output level could be unstable by cross conduction current which is generated at detector threshold level or at released voltage level, therefore, do not use this IC with the connection in Figure A or Figure B.

The connection in Figure C may cause the oscillation in both R3111xxxxC (CMOS Output) and R3111xxxxA/B (Nch Open Drain Output), therefore do not use R3111x Series with the connection in Figure C.

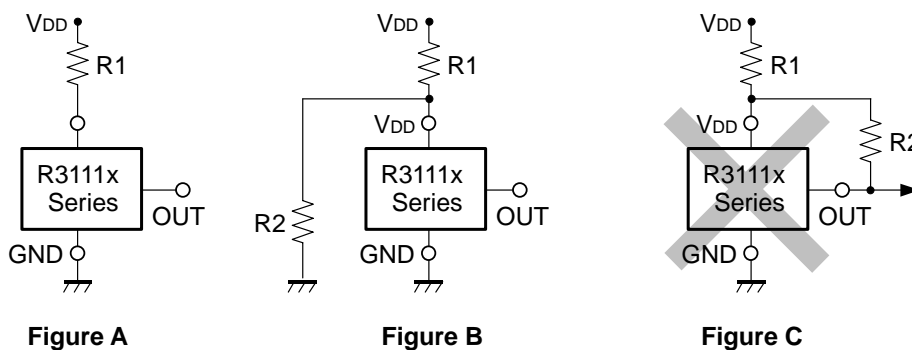

• TO-92 (SC-43A)

Unit: mm

PACKAGE DIMENSIONS

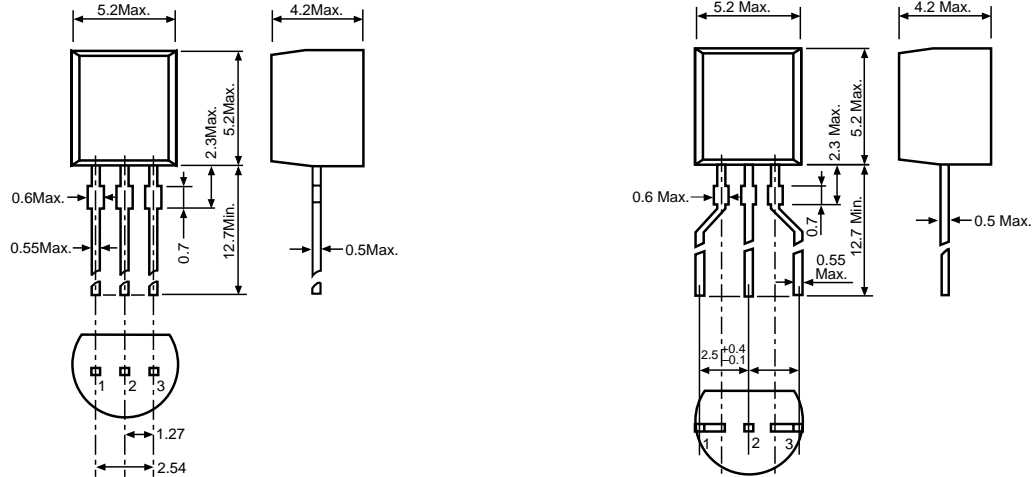

TAPING SPECIFICATION

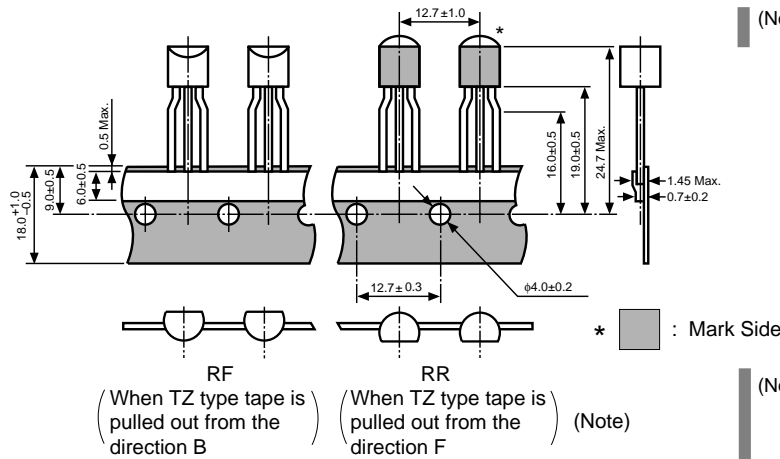

(Note) When taping is performed, the pins of TO-92 are subjected to a particular forming.

(Note) TZ type tape is not in the form of a reel, but is packed in a zigzag state in box. Therefore, the tape can be used as either an RF type tape or an RR type tape, depending upon the pulling out direction (B or F).

TAPING REEL DIMENSIONS (RF, RR)

(1 reel=2000pcs)

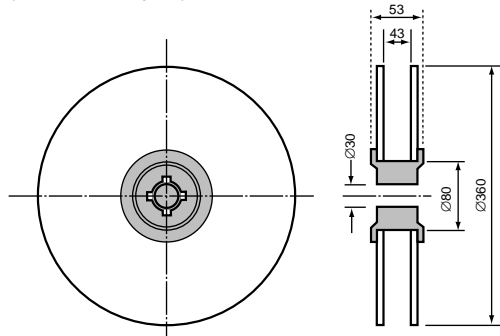

PACKING BOX DIMENSIONS (TZ)

(1 box=2500pcs)

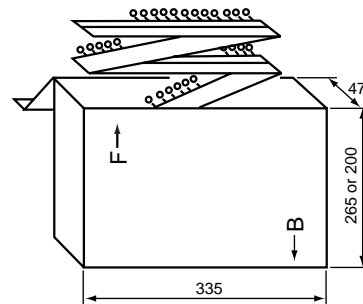

## POWER DISSIPATION (TO-92)

This specification is at mounted on board.

Measurement Result (T<sub>opt</sub>=25°C, T<sub>jmax</sub>=125°C)

	Free Air
Power Dissipation	300mW
Thermal Resistance	$\theta_{ja}=(125-25^{\circ}\text{C})/0.3\text{W}=333^{\circ}\text{C/W}$

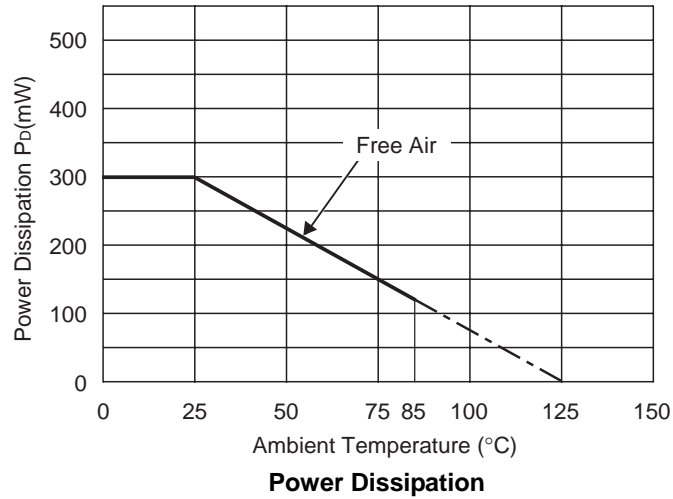

- SOT-89 (SC-62)

Unit: mm

PACKAGE DIMENSIONS

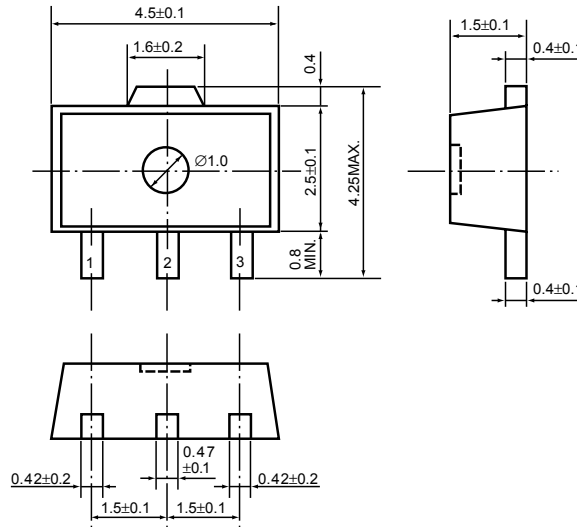

TAPING SPECIFICATION (T1: Standard Type)

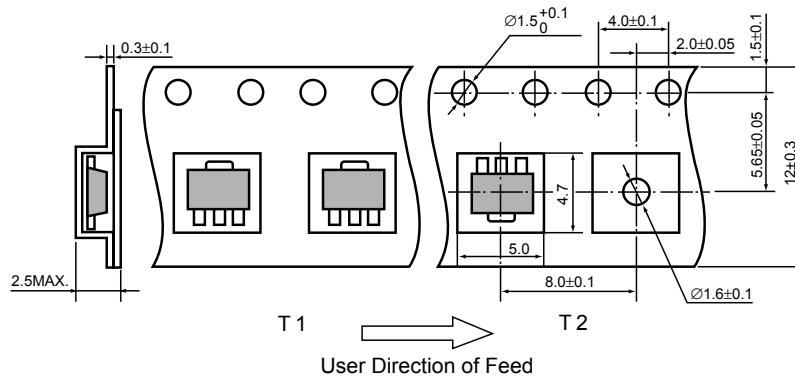

TAPING REEL DIMENSIONS

(1reel=1000pcs)

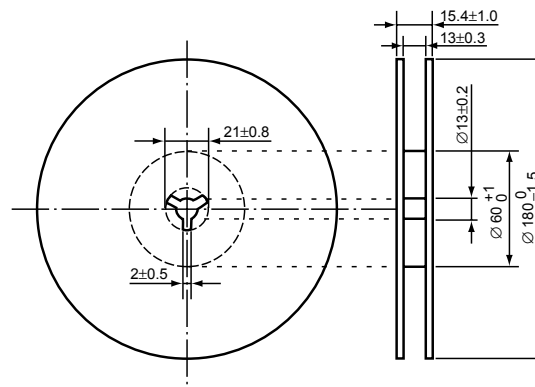

**POWER DISSIPATION (SOT-89)**

This specification is at mounted on board. Power Dissipation ( $P_D$ ) depends on conditions of mounting on board. This specification is based on the measurement at the condition below:

Measurement Conditions

	Standard Land Pattern
Environment	Mounting on Board (Wind velocity=0m/s)
Board Material	Glass cloth epoxy plactic (Double sided)
Board Dimensions	50mm × 50mm × 1.6mm
Copper Ratio	Top side : Approx. 10% , Back side : Approx. 100%
Through-hole	-

Measurement Result

( $T_{opt}=25^{\circ}C, T_{jmax}=125^{\circ}C$ )

	Standard Land Pattern	Free Air
Power Dissipation	900mW	500mW
Thermal Resistance	$\theta_{ja}=(125-25^{\circ}C)/0.9W=111^{\circ}C/W$	200 $^{\circ}C/W$

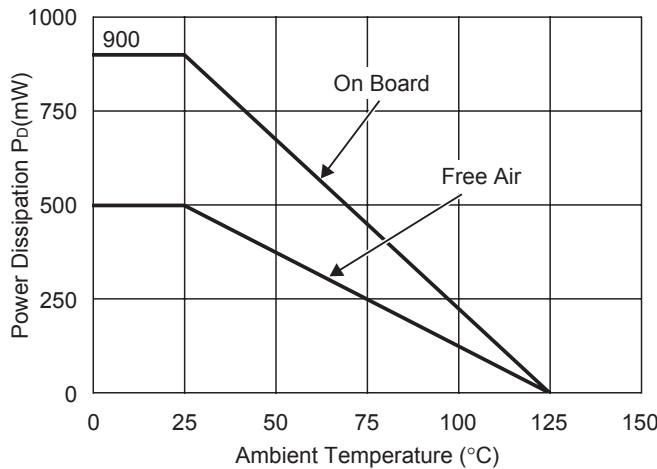

**Power Dissipation**

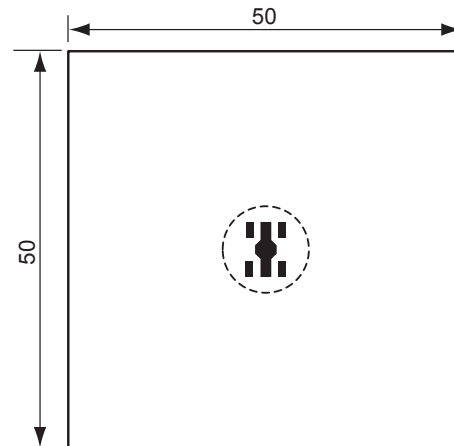

**Measurement Board Pattern**

○ IC Mount Area (Unit : mm)

**RECOMMENDED LAND PATTERN (SOT-89)**

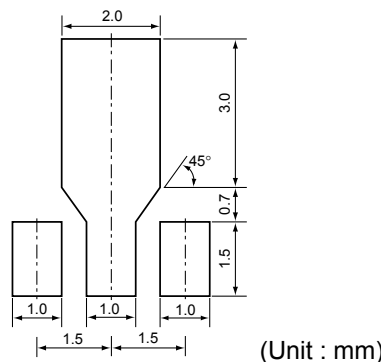

- SOT-23-5 (SC-74A)

Unit: mm

**PACKAGE DIMENSIONS**

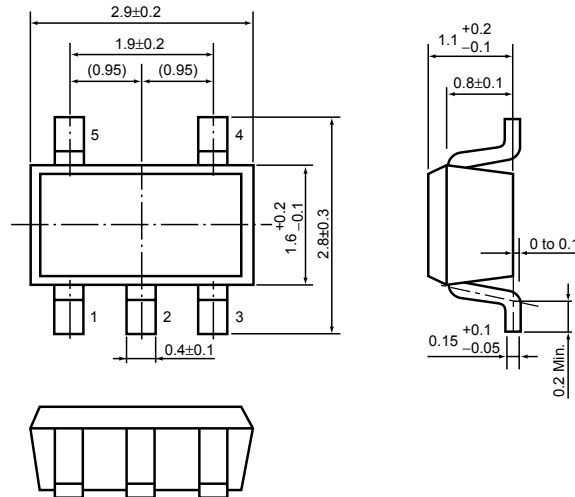

**TAPING SPECIFICATION**

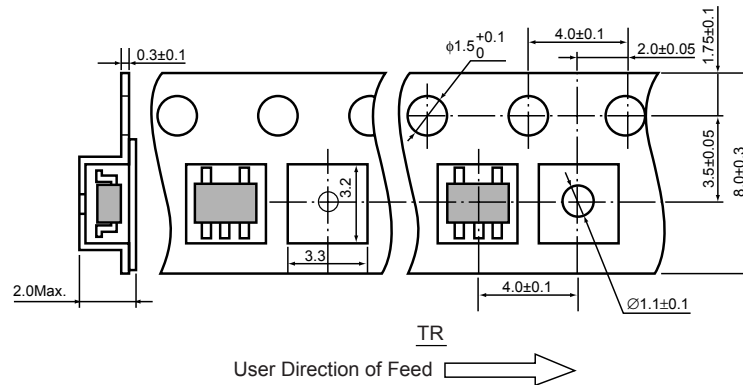

**TAPING REEL DIMENSIONS REUSE REEL (EIAJ-RRM-08Bc)**

(1reel=3000pcs)

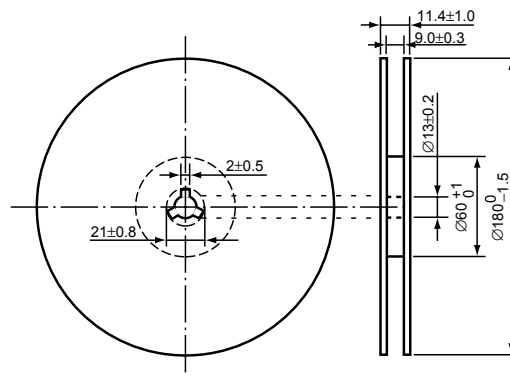

### POWER DISSIPATION (SOT-23-5)

This specification is at mounted on board. Power Dissipation ( $P_D$ ) depends on conditions of mounting on board. This specification is based on the measurement at the condition below: (Power Dissipation (SOT-23-5) is substitution of SOT-23-6.)

Measurement Conditions

	Standard Land Pattern
Environment	Mounting on Board (Wind velocity=0m/s)
Board Material	Glass cloth epoxy plactic (Double sided)
Board Dimensions	40mm × 40mm × 1.6mm
Copper Ratio	Top side : Approx. 50% , Back side : Approx. 50%
Through-hole	φ0.5mm × 44pcs

Measurement Result

( $T_{opt}=25^{\circ}C, T_{jmax}=125^{\circ}C$ )

	Standard Land Pattern	Free Air
Power Dissipation	420mW	250mW
Thermal Resistance	$\theta_{ja}=(125-25^{\circ}C)/0.42W=263^{\circ}C/W$	400 $^{\circ}C/W$

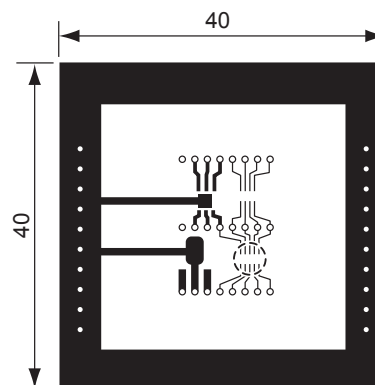
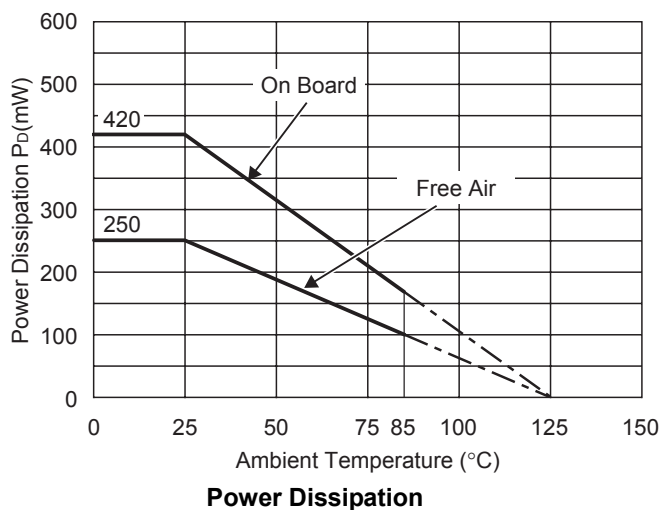

Measurement Board Pattern

○ IC Mount Area Unit : mm

### RECOMMENDED LAND PATTERN

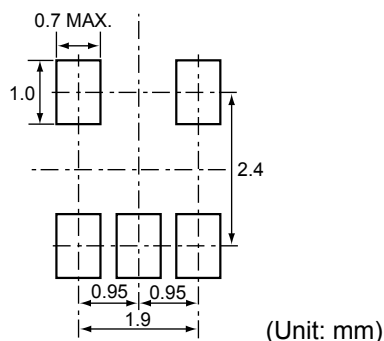



- SOT-23-3 (SC-59A)

Unit: mm

PACKAGE DIMENSIONS

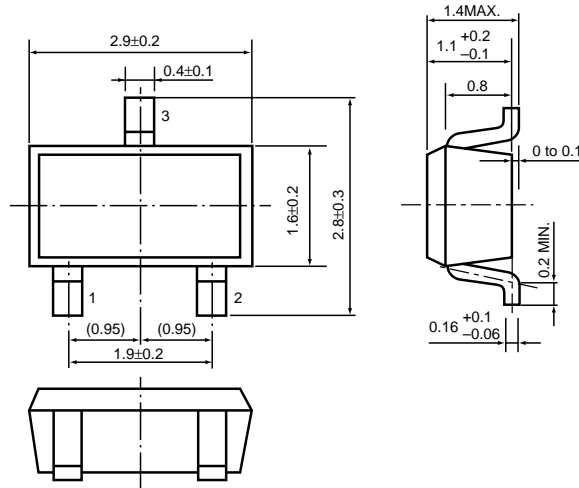

TAPING SPECIFICATION (T1: Standard Type)

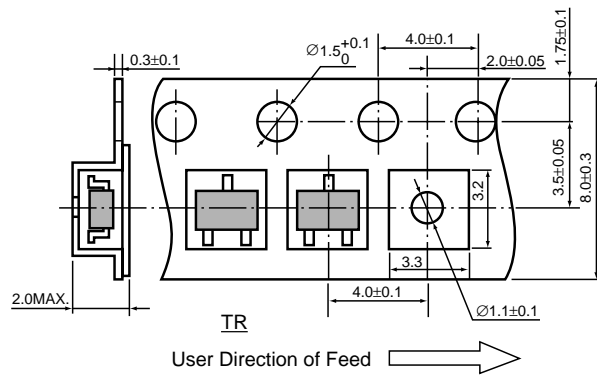

TAPING REEL DIMENSIONS

(1reel=3000pcs)

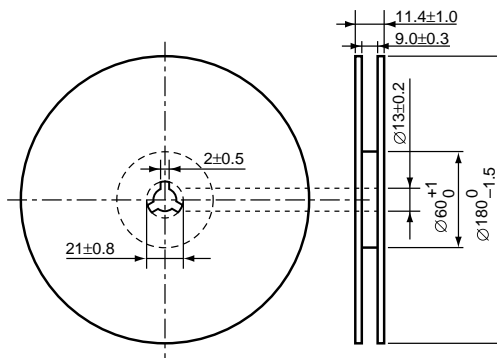

### POWER DISSIPATION (SOT-23-3)

This specification is at mounted on board. Power Dissipation ( $P_D$ ) depends on conditions of mounting on board. This specification is based on the measurement at the condition below: (Power Dissipation (SOT-23-3) is substitution of SOT-23-6.)

Measurement Conditions

	Standard Land Pattern
Environment	Mounting on Board (Wind velocity=0m/s)
Board Material	Glass cloth epoxy plactic (Double sided)
Board Dimensions	40mm × 40mm × 1.6mm
Copper Ratio	Top side : Approx. 50% , Back side : Approx. 50%
Through-hole	φ0.5mm × 44pcs

Measurement Result

( $T_{opt}=25^{\circ}C, T_{jmax}=125^{\circ}C$ )

	Standard Land Pattern	Free Air
Power Dissipation	420mW	250mW
Thermal Resistance	$\theta_{ja}=(125-25^{\circ}C)/0.42W=263^{\circ}C/W$	400 $^{\circ}C/W$

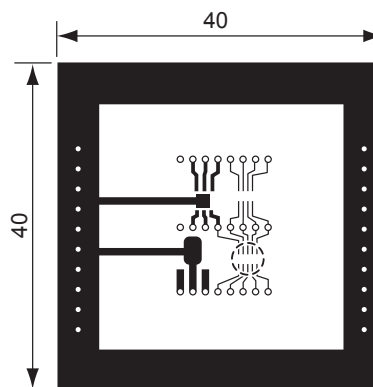
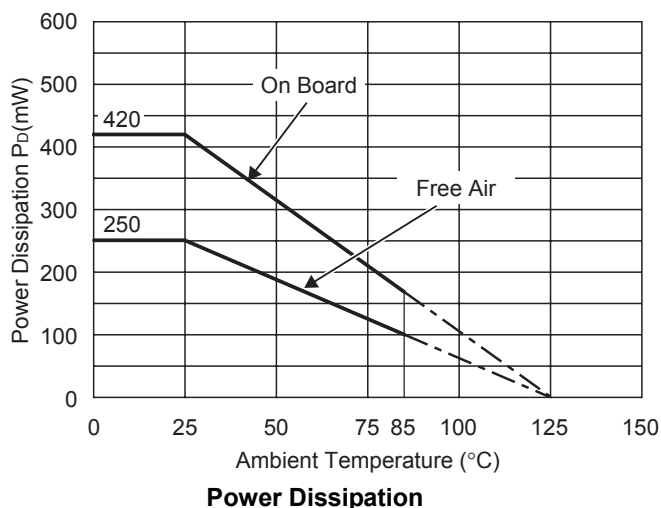

Measurement Board Pattern

○ IC Mount Area Unit : mm

### RECOMMENDED LAND PATTERN (SOT-23-3)

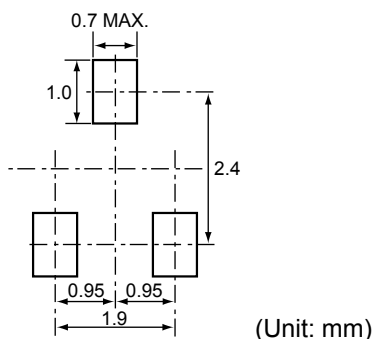

• SC-82AB

Unit: mm

PACKAGE DIMENSIONS

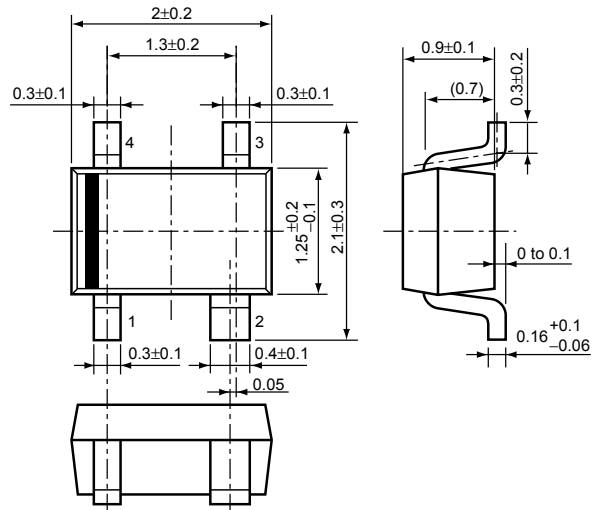

TAPING SPECIFICATION

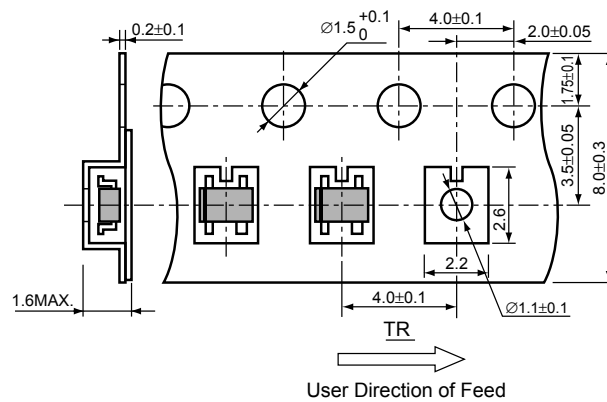

TAPING REEL DIMENSIONS

(1reel=3000pcs)

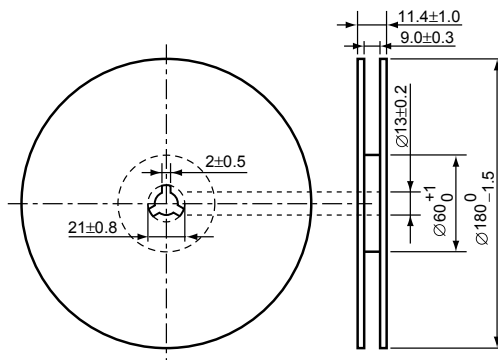

**RICOH**

### POWER DISSIPATION (SC-82AB)

This specification is at mounted on board. Power Dissipation ( $P_D$ ) depends on conditions of mounting on board. This specification is based on the measurement at the condition below:

Measurement Conditions

	Standard Land Pattern
Environment	Mounting on Board (Wind velocity=0m/s)
Board Material	Glass cloth epoxy plactic (Double sided)
Board Dimensions	40mm × 40mm × 1.6mm
Copper Ratio	Top side : Approx. 50% , Back side : Approx. 50%
Through-hole	φ0.5mm × 44pcs

Measurement Result

( $T_{opt}=25^{\circ}C, T_{jmax}=125^{\circ}C$ )

	Standard Land Pattern	Free Air
Power Dissipation	380mW	150mW
Thermal Resistance	$\theta_{ja}=(125-25^{\circ}C)/0.38W=263^{\circ}C/W$	667 $^{\circ}C/W$

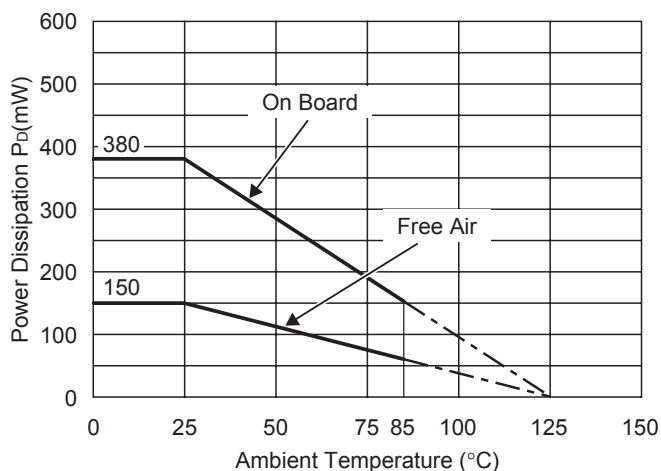

Power Dissipation

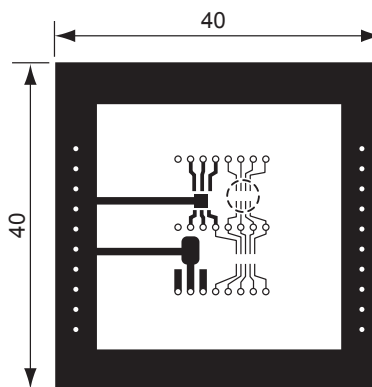

Measurement Board Pattern

○ IC Mount Area (Unit : mm)

### RECOMMENDED LAND PATTERN

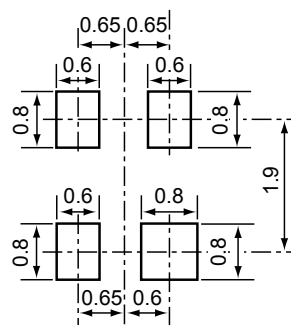

(Unit: mm)

• SON1612-6

Unit: mm

**PACKAGE DIMENSIONS**

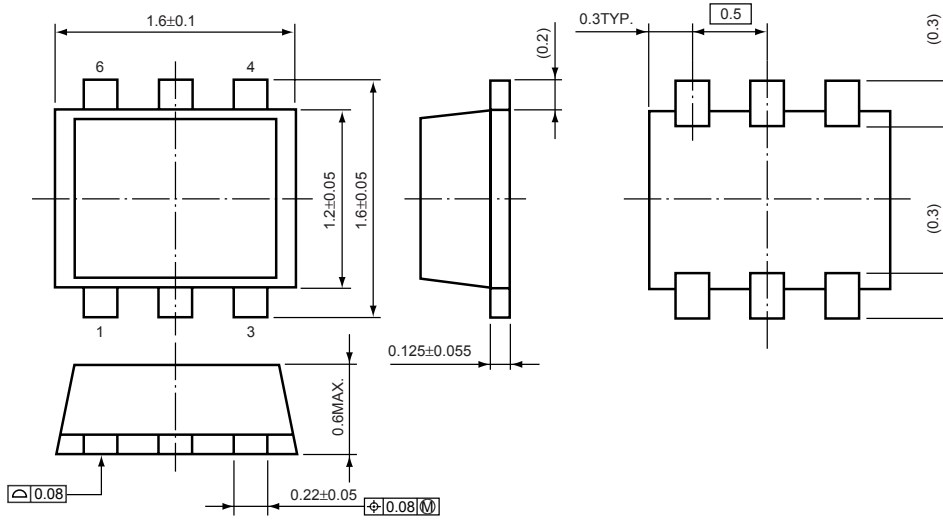

**TAPING SPECIFICATION**

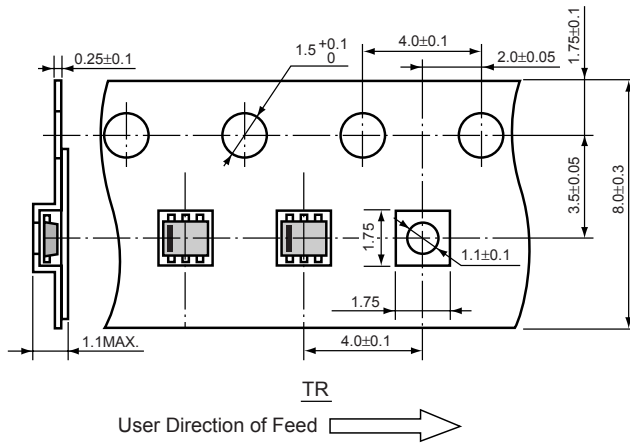

**TAPING REEL DIMENSIONS**

(1reel=4000pcs)

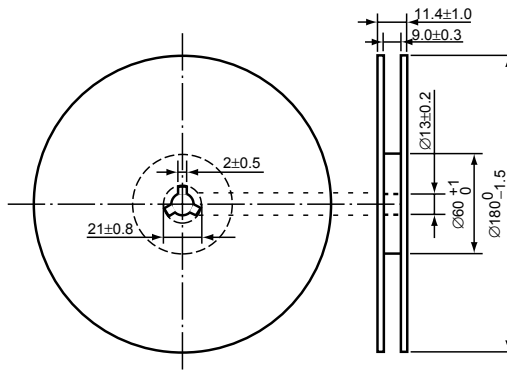

## Power Dissipation (SON1612-6)

This specification is at mounted on board.

Power Dissipation ( $P_D$ ) depends on conditions of mounting on board. This specification is based on the measurement at the condition below:

### Measurement Conditions

	Standard Land Pattern
Environment	Mounting on Board (Wind velocity=0m/s)
Board Material	Glass cloth epoxy plastic (Double sided)
Board Dimensions	40mm × 40mm × 1.6mm
Copper Ratio	Top side : Approx. 50%, Back side : Approx.50%
Through-hole	φ0.5mm × 24pcs

### Measurement Result

( $T_{opt}=25^{\circ}C, T_{jmax}=125^{\circ}C$ )

	Standard Land Pattern
Power Dissipation	500mW
Thermal Resistance	$\theta_{ja}=(125-25^{\circ}C)/0.5W=200^{\circ}C/W$

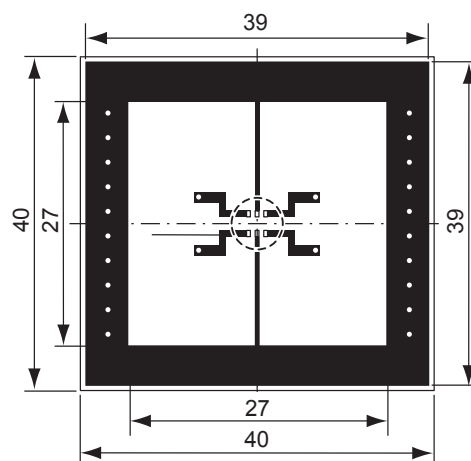
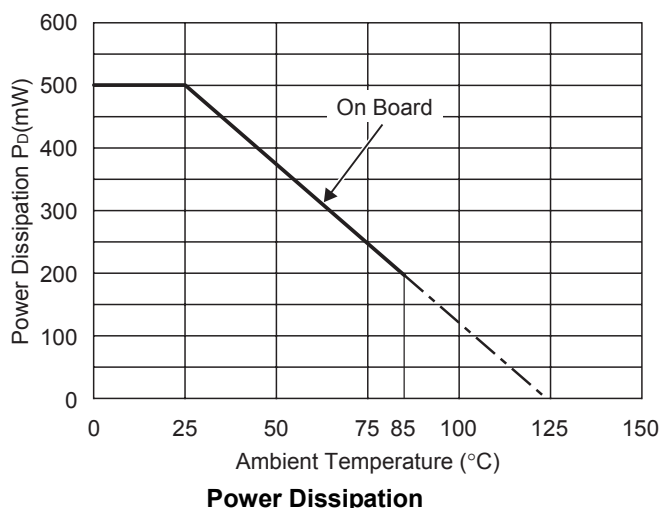

Measurement Board Pattern

○ IC Mount Area Unit : mm

## RECOMMENDED LAND PATTERN

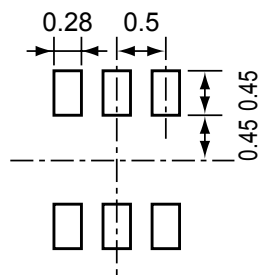

(Unit: mm)

## R3111E SERIES MARK SPECIFICATION

### • TO-92 (SC-43A)

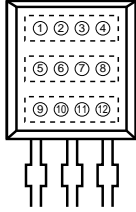

- ① to ⑤ : Series Name: R3111 (fixed)
- ⑥, ⑦ : Detector Threshold: ex.  $-V_{DET}=3.0V \rightarrow 30$
- ⑧ : Output Type: Nch  $\rightarrow$  A, CMOS  $\rightarrow$  C
- ⑨ to ⑫ : Lot Number

## R3111H SERIES MARK SPECIFICATION

● SOT-89 (SC-62)

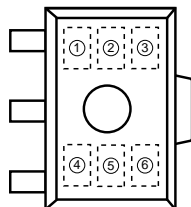

① to ④ : Product Code (refer to Part Number vs. Product Code)

⑤, ⑥ : Lot Number

● Part Number vs. Product Code

Part Number	Product Code			
	①	②	③	④
R3111H091A	A	0	9	A
R3111H101A	A	1	0	A
R3111H111A	A	1	1	A
R3111H121A	A	1	2	A
R3111H131A	A	1	3	A
R3111H141A	A	1	4	A
R3111H151A	A	1	5	A
R3111H161A	A	1	6	A
R3111H171A	A	1	7	A
R3111H181A	A	1	8	A
R3111H191A	A	1	9	A
R3111H201A	A	2	0	A
R3111H211A	A	2	1	A
R3111H221A	A	2	2	A
R3111H231A	A	2	3	A
R3111H241A	A	2	4	A
R3111H251A	A	2	5	A
R3111H261A	A	2	6	A
R3111H271A	A	2	7	A
R3111H281A	A	2	8	A
R3111H291A	A	2	9	A
R3111H301A	A	3	0	A
R3111H311A	A	3	1	A
R3111H321A	A	3	2	A
R3111H331A	A	3	3	A
R3111H341A	A	3	4	A

Part Number	Product Code			
	①	②	③	④
R3111H351A	A	3	5	A
R3111H361A	A	3	6	A
R3111H371A	A	3	7	A
R3111H381A	A	3	8	A
R3111H391A	A	3	9	A
R3111H401A	A	4	0	A
R3111H411A	A	4	1	A
R3111H421A	A	4	2	A
R3111H431A	A	4	3	A
R3111H441A	A	4	4	A
R3111H451A	A	4	5	A
R3111H461A	A	4	6	A
R3111H471A	A	4	7	A
R3111H481A	A	4	8	A
R3111H491A	A	4	9	A
R3111H501A	A	5	0	A
R3111H511A	A	5	1	A
R3111H521A	A	5	2	A
R3111H531A	A	5	3	A
R3111H541A	A	5	4	A
R3111H551A	A	5	5	A
R3111H561A	A	5	6	A
R3111H571A	A	5	7	A
R3111H581A	A	5	8	A
R3111H591A	A	5	9	A
R3111H601A	A	6	0	A

Part Number	Product Code			
	①	②	③	④
R3111H091C	A	0	9	C
R3111H101C	A	1	0	C
R3111H111C	A	1	1	C
R3111H121C	A	1	2	C
R3111H131C	A	1	3	C
R3111H141C	A	1	4	C
R3111H151C	A	1	5	C
R3111H161C	A	1	6	C
R3111H171C	A	1	7	C
R3111H181C	A	1	8	C
R3111H191C	A	1	9	C
R3111H201C	A	2	0	C
R3111H211C	A	2	1	C
R3111H221C	A	2	2	C
R3111H231C	A	2	3	C
R3111H241C	A	2	4	C
R3111H251C	A	2	5	C
R3111H261C	A	2	6	C
R3111H271C	A	2	7	C
R3111H281C	A	2	8	C
R3111H291C	A	2	9	C
R3111H301C	A	3	0	C
R3111H311C	A	3	1	C
R3111H321C	A	3	2	C
R3111H331C	A	3	3	C
R3111H341C	A	3	4	C

Part Number	Product Code			
	①	②	③	④
R3111H351C	A	3	5	C
R3111H361C	A	3	6	C
R3111H371C	A	3	7	C
R3111H381C	A	3	8	C
R3111H391C	A	3	9	C
R3111H401C	A	4	0	C
R3111H411C	A	4	1	C
R3111H421C	A	4	2	C
R3111H431C	A	4	3	C
R3111H441C	A	4	4	C
R3111H451C	A	4	5	C
R3111H461C	A	4	6	C
R3111H471C	A	4	7	C
R3111H481C	A	4	8	C
R3111H491C	A	4	9	C
R3111H501C	A	5	0	C
R3111H511C	A	5	1	C
R3111H521C	A	5	2	C
R3111H531C	A	5	3	C
R3111H541C	A	5	4	C
R3111H551C	A	5	5	C
R3111H561C	A	5	6	C
R3111H571C	A	5	7	C
R3111H581C	A	5	8	C
R3111H591C	A	5	9	C
R3111H601C	A	6	0	C



**R3111Nxx1 SERIES MARK SPECIFICATION**

● SOT-23-5 (SC-74A)

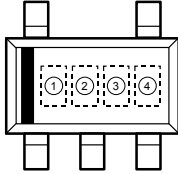

①, ② : Product Code (refer to Part Number vs. Product Code)

③, ④ : Lot Number

● Part Number vs. Product Code

Part Number	Product Code	
	①	②
R3111N091A	9	A
R3111N101A	0	B
R3111N111A	1	B
R3111N121A	2	B
R3111N131A	3	B
R3111N141A	4	B
R3111N151A	5	B
R3111N161A	6	B
R3111N171A	7	B
R3111N181A	8	B
R3111N191A	9	B
R3111N201A	0	C
R3111N211A	1	C
R3111N221A	2	C
R3111N231A	3	C
R3111N241A	4	C
R3111N251A	5	C
R3111N261A	6	C
R3111N271A	7	C
R3111N281A	8	C
R3111N291A	9	C
R3111N301A	0	D
R3111N311A	1	D
R3111N321A	2	D
R3111N331A	3	D
R3111N341A	4	D

Part Number	Product Code	
	①	②
R3111N351A	5	D
R3111N361A	6	D
R3111N371A	7	D
R3111N381A	8	D
R3111N391A	9	D
R3111N401A	0	E
R3111N411A	1	E
R3111N421A	2	E
R3111N431A	3	E
R3111N441A	4	E
R3111N451A	5	E
R3111N461A	6	E
R3111N471A	7	E
R3111N481A	8	E
R3111N491A	9	E
R3111N501A	0	F
R3111N511A	1	F
R3111N521A	2	F
R3111N531A	3	F
R3111N541A	4	F
R3111N551A	5	F
R3111N561A	6	F
R3111N571A	7	F
R3111N581A	8	F
R3111N591A	9	F
R3111N601A	0	G

Part Number	Product Code	
	①	②
R3111N091C	9	H
R3111N101C	0	J
R3111N111C	1	J
R3111N121C	2	J
R3111N131C	3	J
R3111N141C	4	J
R3111N151C	5	J
R3111N161C	6	J
R3111N171C	7	J
R3111N181C	8	J
R3111N191C	9	J
R3111N201C	0	K
R3111N211C	1	K
R3111N221C	2	K
R3111N231C	3	K
R3111N241C	4	K
R3111N251C	5	K
R3111N261C	6	K
R3111N271C	7	K
R3111N281C	8	K
R3111N291C	9	K
R3111N301C	0	L
R3111N311C	1	L
R3111N321C	2	L
R3111N331C	3	L
R3111N341C	4	L

Part Number	Product Code	
	①	②
R3111N351C	5	L
R3111N361C	6	L
R3111N371C	7	L
R3111N381C	8	L
R3111N391C	9	L
R3111N401C	0	M
R3111N411C	1	M
R3111N421C	2	M
R3111N431C	3	M
R3111N441C	4	M
R3111N451C	5	M
R3111N461C	6	M
R3111N471C	7	M
R3111N481C	8	M
R3111N491C	9	M
R3111N501C	0	N
R3111N511C	1	N
R3111N521C	2	N
R3111N531C	3	N
R3111N541C	4	N
R3111N551C	5	N
R3111N561C	6	N
R3111N571C	7	N
R3111N581C	8	N
R3111N591C	9	N
R3111N601C	0	P

## R3111Nxx2x SERIES MARK SPECIFICATION

● SOT-23-3 (SC-59A)

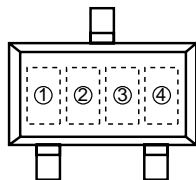

①, ② : Product Code (refer to Part Number vs. Product Code)

③, ④ : Lot Number

● Part Number vs. Product Code

Part Number	Product Code	
	①	②
R3111N092A	A	9
R3111N102A	B	0
R3111N112A	B	1
R3111N122A	B	2
R3111N132A	B	3
R3111N142A	B	4
R3111N152A	B	5
R3111N162A	B	6
R3111N172A	B	7
R3111N182A	B	8
R3111N192A	B	9
R3111N202A	C	0
R3111N212A	C	1
R3111N222A	C	2
R3111N232A	C	3
R3111N242A	C	4
R3111N252A	C	5
R3111N262A	C	6
R3111N272A	C	7
R3111N282A	C	8
R3111N292A	C	9
R3111N302A	D	0
R3111N312A	D	1
R3111N322A	D	2
R3111N332A	D	3
R3111N342A	D	4

Part Number	Product Code	
	①	②
R3111N352A	D	5
R3111N362A	D	6
R3111N372A	D	7
R3111N382A	D	8
R3111N392A	D	9
R3111N402A	E	0
R3111N412A	E	1
R3111N422A	E	2
R3111N432A	E	3
R3111N442A	E	4
R3111N452A	E	5
R3111N462A	E	6
R3111N472A	E	7
R3111N482A	E	8
R3111N492A	E	9
R3111N502A	F	0
R3111N512A	F	1
R3111N522A	F	2
R3111N532A	F	3
R3111N542A	F	4
R3111N552A	F	5
R3111N562A	F	6
R3111N572A	F	7
R3111N582A	F	8
R3111N592A	F	9
R3111N602A	G	0

Part Number	Product Code	
	①	②
R3111N092C	H	9
R3111N102C	J	0
R3111N112C	J	1
R3111N122C	J	2
R3111N132C	J	3
R3111N142C	J	4
R3111N152C	J	5
R3111N162C	J	6
R3111N172C	J	7
R3111N182C	J	8
R3111N192C	J	9
R3111N202C	K	0
R3111N212C	K	1
R3111N222C	K	2
R3111N232C	K	3
R3111N242C	K	4
R3111N252C	K	5
R3111N262C	K	6
R3111N272C	K	7
R3111N282C	K	8
R3111N292C	K	9
R3111N302C	L	0
R3111N312C	L	1
R3111N322C	L	2
R3111N332C	L	3
R3111N342C	L	4

Part Number	Product Code	
	①	②
R3111N352C	L	5
R3111N362C	L	6
R3111N372C	L	7
R3111N382C	L	8
R3111N392C	L	9
R3111N402C	M	0
R3111N412C	M	1
R3111N422C	M	2
R3111N432C	M	3
R3111N442C	M	4
R3111N452C	M	5
R3111N462C	M	6
R3111N472C	M	7
R3111N482C	M	8
R3111N492C	M	9
R3111N502C	N	0
R3111N512C	N	1
R3111N522C	N	2
R3111N532C	N	3
R3111N542C	N	4
R3111N552C	N	5
R3111N562C	N	6
R3111N572C	N	7
R3111N582C	N	8
R3111N592C	N	9
R3111N602C	P	0

R3111Q SERIES MARK SPECIFICATION

● SC-82AB

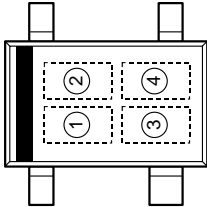

①, ② : Product Code (refer to Part Number vs. Product Code)

③, ④ : Lot Number

● Part Number vs. Product Code

Part Number	Product Code	
	①	②
R3111Q091A	K	9
R3111Q101A	L	0
R3111Q111A	L	1
R3111Q121A	L	2
R3111Q131A	L	3
R3111Q141A	L	4
R3111Q151A	L	5
R3111Q161A	L	6
R3111Q171A	L	7
R3111Q181A	L	8
R3111Q191A	L	9
R3111Q201A	M	0
R3111Q211A	M	1
R3111Q221A	M	2
R3111Q231A	M	3
R3111Q241A	M	4
R3111Q251A	M	5
R3111Q261A	M	6
R3111Q271A	M	7
R3111Q281A	M	8
R3111Q291A	M	9
R3111Q301A	N	0
R3111Q311A	N	1
R3111Q321A	N	2
R3111Q331A	N	3
R3111Q341A	N	4
R3111Q351A	N	5
R3111Q361A	N	6
R3111Q371A	N	7
R3111Q381A	N	8
R3111Q391A	N	9
R3111Q401A	P	0
R3111Q411A	P	1
R3111Q421A	P	2
R3111Q431A	P	3
R3111Q441A	P	4
R3111Q451A	P	5
R3111Q461A	P	6
R3111Q471A	P	7

Part Number	Product Code	
	①	②
R3111Q481A	P	8
R3111Q491A	P	9
R3111Q501A	R	0
R3111Q511A	R	1
R3111Q521A	R	2
R3111Q531A	R	3
R3111Q541A	R	4
R3111Q551A	R	5
R3111Q561A	R	6
R3111Q571A	R	7
R3111Q581A	R	8
R3111Q591A	R	9
R3111Q601A	S	0
R3111Q091B	0	9
R3111Q101B	1	0
R3111Q111B	1	1
R3111Q121B	1	2
R3111Q131B	1	3
R3111Q141B	1	4
R3111Q151B	1	5
R3111Q161B	1	6
R3111Q171B	1	7
R3111Q181B	1	8
R3111Q191B	1	9
R3111Q201B	2	0
R3111Q211B	2	1
R3111Q221B	2	2
R3111Q231B	2	3
R3111Q241B	2	4
R3111Q251B	2	5
R3111Q261B	2	6
R3111Q271B	2	7
R3111Q281B	2	8
R3111Q291B	2	9
R3111Q301B	3	0
R3111Q311B	3	1
R3111Q321B	3	2
R3111Q331B	3	3
R3111Q341B	3	4

Part Number	Product Code	
	①	②
R3111Q351B	3	5
R3111Q361B	3	6
R3111Q371B	3	7
R3111Q381B	3	8
R3111Q391B	3	9
R3111Q401B	4	0
R3111Q411B	4	1
R3111Q421B	4	2
R3111Q431B	4	3
R3111Q441B	4	4
R3111Q451B	4	5
R3111Q461B	4	6
R3111Q471B	4	7
R3111Q481B	4	8
R3111Q491B	4	9
R3111Q501B	5	0
R3111Q511B	5	1
R3111Q521B	5	2
R3111Q531B	5	3
R3111Q541B	5	4
R3111Q551B	5	5
R3111Q561B	5	6
R3111Q571B	5	7
R3111Q581B	5	8
R3111Q591B	5	9
R3111Q601B	6	0
R3111Q091C	T	9
R3111Q101C	U	0
R3111Q111C	U	1
R3111Q121C	U	2
R3111Q131C	U	3
R3111Q141C	U	4
R3111Q151C	U	5
R3111Q161C	U	6
R3111Q171C	U	7
R3111Q181C	U	8
R3111Q191C	U	9
R3111Q201C	V	0
R3111Q211C	V	1

Part Number	Product Code	
	①	②
R3111Q221C	V	2
R3111Q231C	V	3
R3111Q241C	V	4
R3111Q251C	V	5
R3111Q261C	V	6
R3111Q271C	V	7
R3111Q281C	V	8
R3111Q291C	V	9
R3111Q301C	W	0
R3111Q311C	W	1
R3111Q321C	W	2
R3111Q331C	W	3
R3111Q341C	W	4
R3111Q351C	W	5
R3111Q361C	W	6
R3111Q371C	W	7
R3111Q381C	W	8
R3111Q391C	W	9
R3111Q401C	X	0
R3111Q411C	X	1
R3111Q421C	X	2
R3111Q431C	X	3
R3111Q441C	X	4
R3111Q451C	X	5
R3111Q461C	X	6
R3111Q471C	X	7
R3111Q481C	X	8
R3111Q491C	X	9
R3111Q501C	Y	0
R3111Q511C	Y	1
R3111Q521C	Y	2
R3111Q531C	Y	3
R3111Q541C	Y	4
R3111Q551C	Y	5
R3111Q561C	Y	6
R3111Q571C	Y	7
R3111Q581C	Y	8
R3111Q591C	Y	9
R3111Q601C	Z	0

### R3111D SERIES MARK SPECIFICATION

● SON1612-6

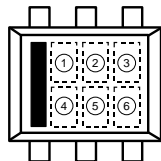

① to ④ : Product Code (refer to Part Number vs. Product Code)

⑤, ⑥ : Lot Number

● Part Number vs. Product Code

Part Number	Product Code			
	①	②	③	④
R3111D091A	A	0	9	A
R3111D101A	A	1	0	A
R3111D111A	A	1	1	A
R3111D121A	A	1	2	A
R3111D131A	A	1	3	A
R3111D141A	A	1	4	A
R3111D151A	A	1	5	A
R3111D161A	A	1	6	A
R3111D171A	A	1	7	A
R3111D181A	A	1	8	A
R3111D191A	A	1	9	A
R3111D201A	A	2	0	A
R3111D211A	A	2	1	A
R3111D221A	A	2	2	A
R3111D231A	A	2	3	A
R3111D241A	A	2	4	A
R3111D251A	A	2	5	A
R3111D261A	A	2	6	A
R3111D271A	A	2	7	A
R3111D281A	A	2	8	A
R3111D291A	A	2	9	A
R3111D301A	A	3	0	A
R3111D311A	A	3	1	A
R3111D321A	A	3	2	A
R3111D331A	A	3	3	A
R3111D341A	A	3	4	A
R3111D351A	A	3	5	A
R3111D361A	A	3	6	A
R3111D371A	A	3	7	A
R3111D381A	A	3	8	A
R3111D391A	A	3	9	A
R3111D401A	A	4	0	A
R3111D411A	A	4	1	A
R3111D421A	A	4	2	A
R3111D431A	A	4	3	A
R3111D441A	A	4	4	A
R3111D451A	A	4	5	A
R3111D461A	A	4	6	A
R3111D471A	A	4	7	A
R3111D481A	A	4	8	A
R3111D491A	A	4	9	A
R3111D501A	A	5	0	A
R3111D511A	A	5	1	A
R3111D521A	A	5	2	A
R3111D531A	A	5	3	A
R3111D541A	A	5	4	A
R3111D551A	A	5	5	A
R3111D561A	A	5	6	A
R3111D571A	A	5	7	A
R3111D581A	A	5	8	A
R3111D591A	A	5	9	A
R3111D601A	A	6	0	A
R3111D091B	A	0	9	B
R3111D101B	A	1	0	B
R3111D111B	A	1	1	B
R3111D121B	A	1	2	B
R3111D131B	A	1	3	B
R3111D141B	A	1	4	B
R3111D151B	A	1	5	B
R3111D161B	A	1	6	B
R3111D171B	A	1	7	B
R3111D181B	A	1	8	B
R3111D191B	A	1	9	B
R3111D201B	A	2	0	B
R3111D211B	A	2	1	B
R3111D221B	A	2	2	B
R3111D231B	A	2	3	B
R3111D241B	A	2	4	B
R3111D251B	A	2	5	B
R3111D261B	A	2	6	B
R3111D271B	A	2	7	B
R3111D281B	A	2	8	B
R3111D291B	A	2	9	B
R3111D301B	A	3	0	B
R3111D311B	A	3	1	B
R3111D321B	A	3	2	B
R3111D331B	A	3	3	B
R3111D341B	A	3	4	B

Part Number	Product Code			
	①	②	③	④
R3111D481A	A	4	8	A
R3111D491A	A	4	9	A
R3111D501A	A	5	0	A
R3111D511A	A	5	1	A
R3111D521A	A	5	2	A
R3111D531A	A	5	3	A
R3111D541A	A	5	4	A
R3111D551A	A	5	5	A
R3111D561A	A	5	6	A
R3111D571A	A	5	7	A
R3111D581A	A	5	8	A
R3111D591A	A	5	9	A
R3111D601A	A	6	0	A
R3111D091B	A	0	9	B
R3111D101B	A	1	0	B
R3111D111B	A	1	1	B
R3111D121B	A	1	2	B
R3111D131B	A	1	3	B
R3111D141B	A	1	4	B
R3111D151B	A	1	5	B
R3111D161B	A	1	6	B
R3111D171B	A	1	7	B
R3111D181B	A	1	8	B
R3111D191B	A	1	9	B
R3111D201B	A	2	0	B
R3111D211B	A	2	1	B
R3111D221B	A	2	2	B
R3111D231B	A	2	3	B
R3111D241B	A	2	4	B
R3111D251B	A	2	5	B
R3111D261B	A	2	6	B
R3111D271B	A	2	7	B
R3111D281B	A	2	8	B
R3111D291B	A	2	9	B
R3111D301B	A	3	0	B
R3111D311B	A	3	1	B
R3111D321B	A	3	2	B
R3111D331B	A	3	3	B
R3111D341B	A	3	4	B

Part Number	Product Code			
	①	②	③	④
R3111D351B	A	3	5	B
R3111D361B	A	3	6	B
R3111D371B	A	3	7	B
R3111D381B	A	3	8	B
R3111D391B	A	3	9	B
R3111D401B	A	4	0	B
R3111D411B	A	4	1	B
R3111D421B	A	4	2	B
R3111D431B	A	4	3	B
R3111D441B	A	4	4	B
R3111D451B	A	4	5	B
R3111D461B	A	4	6	B
R3111D471B	A	4	7	B
R3111D481B	A	4	8	B
R3111D491B	A	4	9	B
R3111D501B	A	5	0	B
R3111D511B	A	5	1	B
R3111D521B	A	5	2	B
R3111D531B	A	5	3	B
R3111D541B	A	5	4	B
R3111D551B	A	5	5	B
R3111D561B	A	5	6	B
R3111D571B	A	5	7	B
R3111D581B	A	5	8	B
R3111D591B	A	5	9	B
R3111D601B	A	6	0	B
R3111D091C	A	0	9	C
R3111D101C	A	1	0	C
R3111D111C	A	1	1	C
R3111D121C	A	1	2	C
R3111D131C	A	1	3	C
R3111D141C	A	1	4	C
R3111D151C	A	1	5	C
R3111D161C	A	1	6	C
R3111D171C	A	1	7	C
R3111D181C	A	1	8	C
R3111D191C	A	1	9	C
R3111D201C	A	2	0	C
R3111D211C	A	2	1	C

Part Number	Product Code			
	①	②	③	④
R3111D221C	A	2	2	C
R3111D231C	A	2	3	C
R3111D241C	A	2	4	C
R3111D251C	A	2	5	C
R3111D261C	A	2	6	C
R3111D271C	A	2	7	C
R3111D281C	A	2	8	C
R3111D291C	A	2	9	C
R3111D301C	A	3	0	C
R3111D311C	A	3	1	C
R3111D321C	A	3	2	C
R3111D331C	A	3	3	C
R3111D341C	A	3	4	C
R3111D351C	A	3	5	C
R3111D361C	A	3	6	C
R3111D371C	A	3	7	C
R3111D381C	A	3	8	C
R3111D391C	A	3	9	C
R3111D401C	A	4	0	C
R3111D411C	A	4	1	C
R3111D421C	A	4	2	C
R3111D431C	A	4	3	C
R3111D441C	A	4	4	C
R3111D451C	A	4	5	C
R3111D461C	A	4	6	C
R3111D471C	A	4	7	C
R3111D481C	A	4	8	C
R3111D491C	A	4	9	C
R3111D501C	A	5	0	C
R3111D511C	A	5	1	C
R3111D521C	A	5	2	C
R3111D531C	A	5	3	C
R3111D541C	A	5	4	C
R3111D551C	A	5	5	C
R3111D561C	A	5	6	C
R3111D571C	A	5	7	C
R3111D581C	A	5	8	C
R3111D591C	A	5	9	C
R3111D601C	A	6	0	C