

**OVERVIEW**

The SM8141 is a transformer-less electroluminescent (EL) sheet lamp driver, capable of driving sheets up to 50cm<sup>2</sup> in size. It employs built-in high withstand voltage output MOS transistors and requires few external components, making it ideal for compact driver units in portable equipment.

**FEATURES**

- Dedicated EL driver
- 50cm<sup>2</sup> maximum EL sheet drive capability
- Noise-less smooth drive waveform
- Two oscillators (EL and coil)(SM8141A)
- Stand-by function (SM8141B)
- High-efficiency MOS transistor driver
- Dual supply operation possible (See TYPICAL APPLICATIONS)
- 2.0 to 5.5V supply operation
- 200Vp-p maximum drive voltage
- 250Hz standard drive frequency
- 8-pinVSOP package
- Chip form

**ORDERING INFORMATION**

DEVICE	PACKAGE
SM8141AV	8pin VSOP
SM8141BV	8pin VSOP
CF8141A	Chip form
CF8141B	Chip form

**PINOUT**

**8pin VSOP (TOP VIEW)**

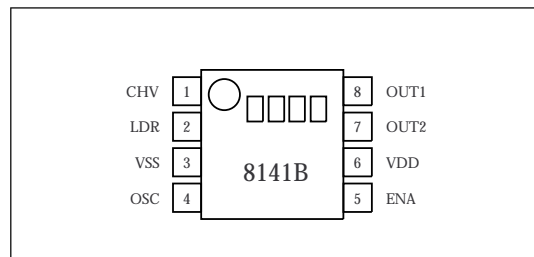
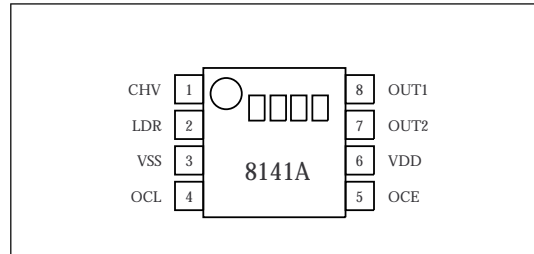

**PACKAGE DIMENSIONS**

(Unit : mm)

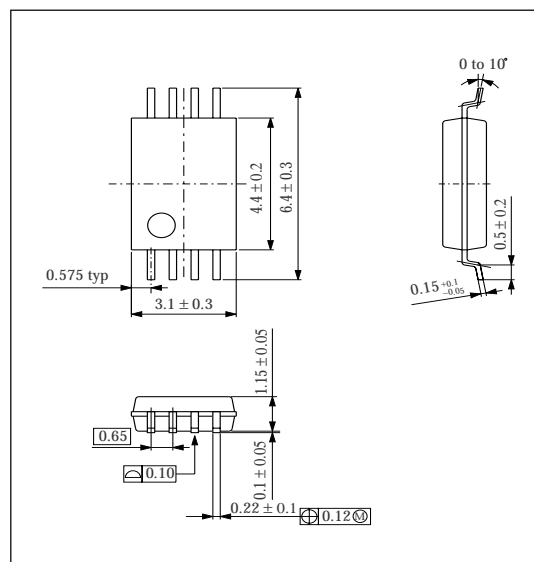

## PAD DIMENSIONS

(Unit : mm)

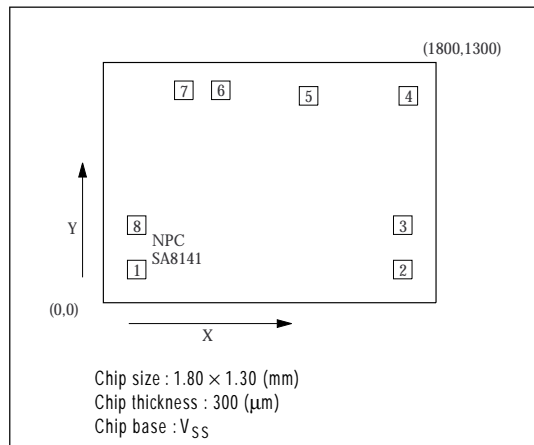

## PIN DESCRIPTION

### • SM8141A

Pin number	Pad number	Name	Pad dimensions		I/O	Function
			X (μm)	Y (μm)		
1	6	CHV	635	1150	I	High-voltage DC input
2	7	LDR	435	1150	O	Booster coil driver output
3	8	VSS	180	420	-	Ground
4	1	OCL	180	180	I	Coil driver oscillator (oscillator frequency determined by external variable resistor)
5	2	OCE	1620	180	I	EL driver oscillator (oscillator frequency determined by external variable resistor)
6	3	VDD	1620	420	-	Supply
7	4	OUT2	1650	1120	O	Output 2
8	5	OUT1	1110	1120	O	Output 1

### • SM8141B

Pin number	Pad number	Name	Pad dimensions		I/O	Function
			X (μm)	Y (μm)		
1	6	CHV	635	1150	I	High-voltage DC input
2	7	LDR	435	1150	O	Booster coil driver output
3	8	VSS	180	420	-	Ground
4	1	OSC	180	180	I	Coil and EL driver oscillator (oscillator frequency determined by external variable resistor)
5	2	ENA	1620	180	I	Enable input (built-in pull-down resistor)
6	3	VDD	1620	420	-	Supply
7	4	OUT2	1650	1120	O	Output 2
8	5	OUT1	1110	1120	O	Output 1

**BLOCK DIAGRAM**

- SM8141A

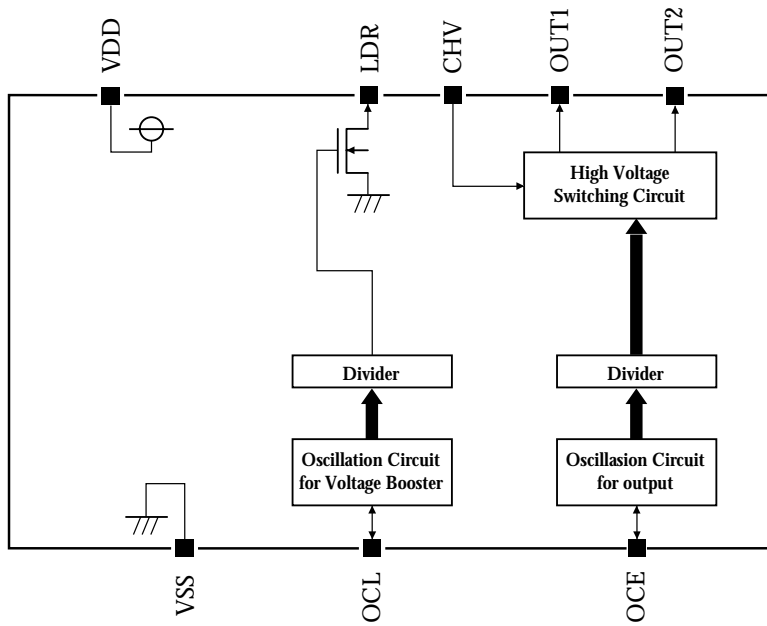

- SM8141B

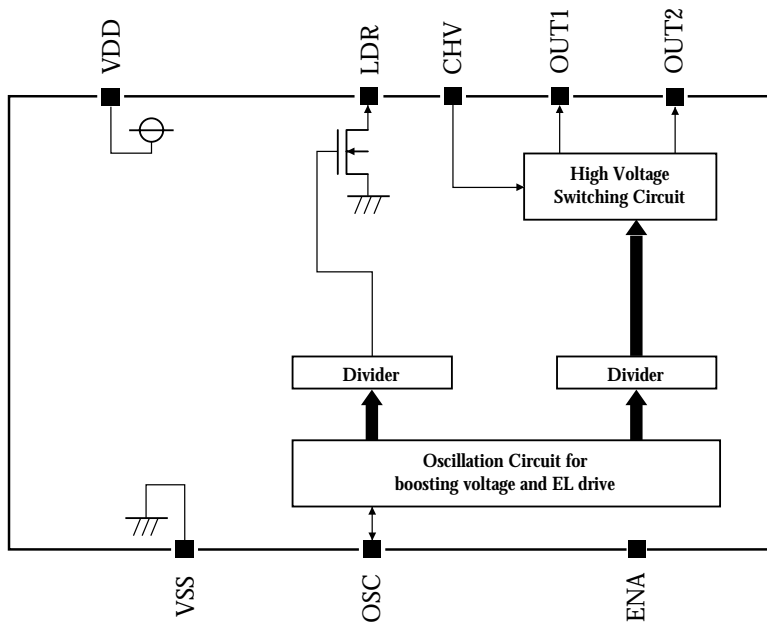

## SPECIFICATIONS

### Absolute Maximum Ratings

$V_{SS} = 0\text{ V}$

Parameter	Symbol	Condition	Rating	Unit
Supply voltage range	$V_{DD}$		- 0.3 to 7.0	V
Input voltage range	$V_{IN}$	All Input pins	$V_{SS} - 0.3$ to $V_{DD} + 0.3$	V
Output voltage	$V_{CHV}$	CHV pin	0.5 to 120	V
	$V_{LDR}$	LDR pin	0.5 to 120	V
	$V_{OUT1/2}$	OUT1 , OUT2 pin	0.5 to 120	V
Storage temperature range	$T_{STG}$		- 55 to 125	°C
Power dissipation	$P_D$	$T_a \leq 85\text{ °C}$	100	mW
Soldering temperature	$T_{SLD}$		255	°C
Soldering time	$t_{SLD}$		10	s

### Recommended Operating Conditions

$V_{SS} = 0\text{ V}$

Parameter	Symbol	Condition	Rating			Unit
			min	typ	max	
Supply voltage	$V_{DD}$		2.0	3.0	5.5	V
Operating temperature	$T_{OPR}$		- 40	-	85	°C
Operating current <sup>1</sup>	$I_{DD2}$	Including coil current, $V_{DD} = 3.0\text{V}$	-	-	60	mA
		Including coil current, $V_{DD} = 5.0\text{V}$	-	-	36	
Coil inductance	$L_{LDR2}$	$f_{LDR} = 64\text{ kHz}$	-	0.47	-	mH

1. Max value is as same as Absolute Maximum Ratings.

## DC Characteristics

$T_a = 25\text{ }^\circ\text{C}$ ,  $V_{SS} = 0\text{ V}$ ,  $V_{DD} = 3.0\text{ V}$  unless otherwise noted

Parameter	Ver.	Symbol	Condition	Rating			Unit
				min	typ	max	
Supply voltage	A / B	$V_{DD}$		2.0	3.0	5.5	V
CHV output voltage	A / B	$V_{CHV}$		0.5	-	100	V
OUT1, OUT2 HIGH-level output voltage	A / B	$V_{OUTH}$		-	-	100	V
OUT1, OUT2 LOW-level output voltage	A / B	$V_{OUTL}$		-	-	0.5	V
LDR output resistance	A / B	$R_{LDR}$	$I_{LDR} = 50\text{ mA}$	-	8.0	12.0	$\Omega$
OCE oscillator frequency	A	$f_{OCE1}$	$R_{OCE} = 200\text{ k}\Omega$	205	256	307	kHz
OCE oscillator frequency range		$f_{OCE2}$		32	-	1024	
OCL oscillator frequency	A	$f_{OCL1}$	$R_{OCL} = 200\text{ k}\Omega$	205	256	307	kHz
OCL oscillator frequency range		$f_{OCL2}$		32	-	1024	
OSC oscillator frequency	B	$f_{OSC1}$	$R_{OSC} = 200\text{ k}\Omega$	205	256	307	kHz
OSC oscillator frequency range		$f_{OSC2}$		32	-	1024	
OUT1, OUT2 output frequency	A / B	$f_{OUT1}$	$R_{OCE}/R_{OSC} = 200\text{ k}\Omega$	200	250	300	Hz
OUT1, OUT2 output frequency range		$f_{OUT2}$		31	-	1000	
LDR inductance driver frequency	A / B	$f_{LDR1}$	$R_{OCL}/R_{OSC} = 200\text{ k}\Omega$	51	64	77	kHz
LDR inductance driver frequency range		$f_{LDR2}$		8	-	256	
ENA HIGH-level input voltage	B	$V_{ENAH}$	ENA = "H", $V_{DD} = 2.0\text{ to }5.5\text{ V}$	$V_{DD} - 0.5$	-	$V_{DD} + 0.3$	V
ENA LOW-level input voltage		$V_{ENAL}$	ENA = "L", $V_{DD} = 2.0\text{ to }5.5\text{ V}$	$V_{SS} - 0.3$	-	$V_{SS} + 0.5$	
ENA input current	B	$I_{ENAH}$	$V_{ENAH} = 3.0\text{ V}$ , $V_{DD} = 3.0\text{ V}$	2.0	4.0	6.0	$\mu\text{A}$
Operating current	A / B	$I_{DD1}$	Excluding coil current	-	-	1	mA
Stand-by current	B	$I_{STB}$	ENA = "L"	-	-	1	$\mu\text{A}$
ENA rise time	B	$t_{ENA}$	$V_{ENAL} \rightarrow V_{ENAH}$	-	-	100	ms

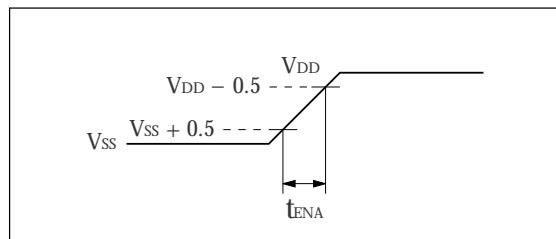

Rise time

TYPICAL APPLICATIONS

• SM8141A

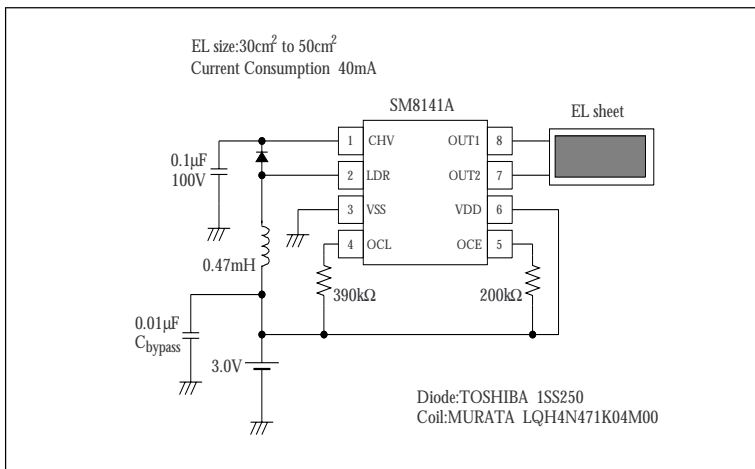
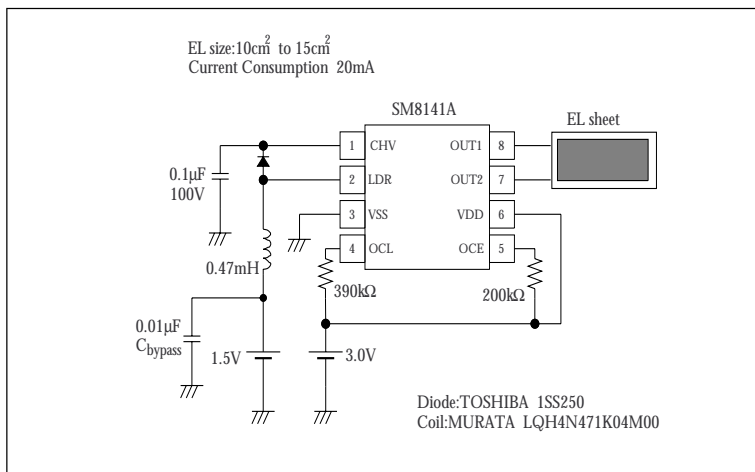
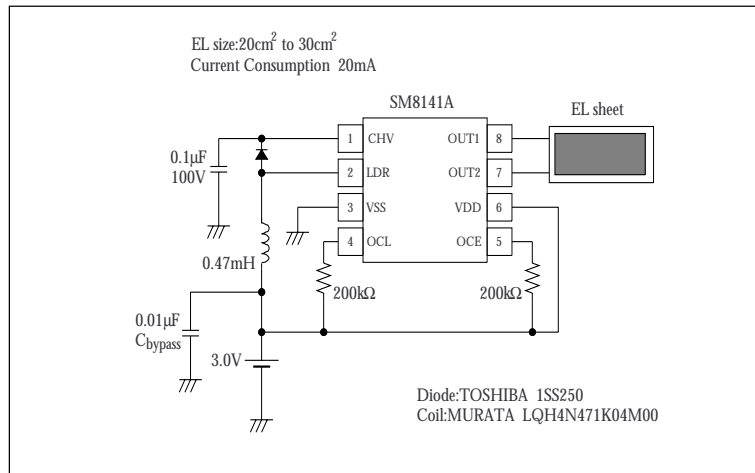

# SM8141

- SM8141B

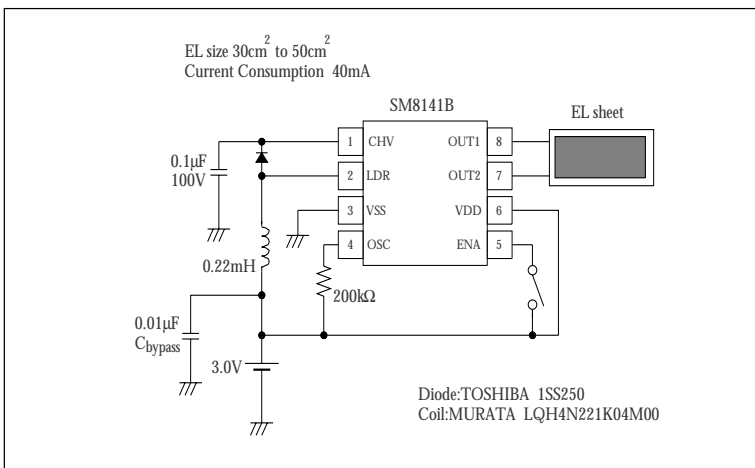
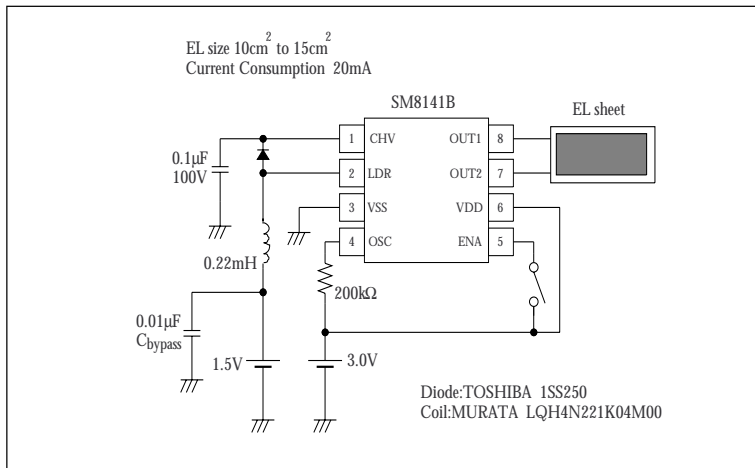
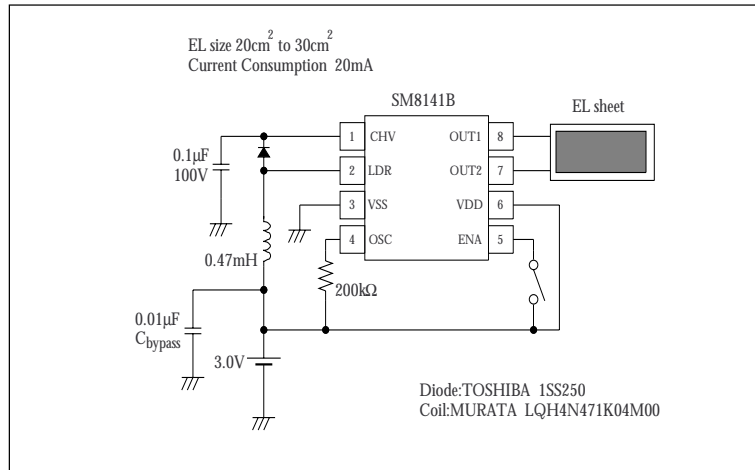

NIPPON PRECISION CIRCUITS INC. reserves the right to make changes to the products described in this data sheet in order to improve the design or performance and to supply the best possible products. Nippon Precision Circuits Inc. assumes no responsibility for the use of any circuits shown in this data sheet, conveys no license under any patent or other rights, and makes no claim that the circuits are free from patent infringement. Applications for any devices shown in this data sheet are for illustration only and Nippon Precision Circuits Inc. makes no claim or warranty that such applications will be suitable for the use specified without further testing or modification. The products described in this data sheet are not intended to use for the apparatus which influence human lives due to the failure or malfunction of the products. Customers are requested to comply with applicable laws and regulations in effect now and hereinafter, including compliance with export controls on the distribution or dissemination of the products. Customers shall not export, directly or indirectly, any products without first obtaining required licenses and approvals from appropriate government agencies.

**NPC**  
NIPPON PRECISION CIRCUITS INC.

NIPPON PRECISION CIRCUITS INC.

4-3, Fukuzumi 2-chome  
Koto-ku, Tokyo 135-8430, Japan  
Telephone: 03-3642-6661  
Facsimile: 03-3642-6698

NC9710DE 1999.10