

### OUTLINE

The Rx5RW Series are CMOS-based voltage regulator ICs with high accuracy output voltage and ultra-low supply current developed. Each of these ICs consists of a driver transistor, a voltage reference unit, an error amplifier, resistors for setting output voltage and a current limit circuit.

The output voltage of these ICs is fixed with high accuracy.

Even if  $V_{OUT}$  is shorted to GND, the included current limit circuit protects the ICs from the destruction. Furthermore, Rx5RWxxA/B have a chip enable function, so that the supply current on standby can be minimized.

Since the packages for these ICs are SC-82AB (Super Mini-mold) package and SON1612-6, high density mounting of the ICs on boards is possible.

### FEATURES

- Ultra-Low Supply Current..... Typ. 1.5 $\mu$ A  
(except pull-up/pull-down current for  $\overline{CE}$  /CE pin)
- Standby Current ..... Typ. 0.1 $\mu$ A
- Dropout Voltage ..... Typ. 40mV ( $I_{OUT}=1$ mA, Rx5RW30A/B)
- Low Temperature-Drift Coefficient of Output Voltage... Typ.  $\pm 100$ ppm/ $^{\circ}$ C
- Excellent Line Regulation ..... Typ. 0.05%/V
- High Accuracy Output Voltage .....  $\pm 2.0\%$
- Ultra-Small Packages ..... SC-82AB (Super Mini-mold), SON1612-6
- Built-in Current Limit Circuits

### APPLICATIONS

- Power source for battery-powered equipment.
- Power source for cameras, VCRs, camcorders, hand-held audio instruments and hand-held communication equipment.
- Precision voltage references.

## BLOCK DIAGRAMS

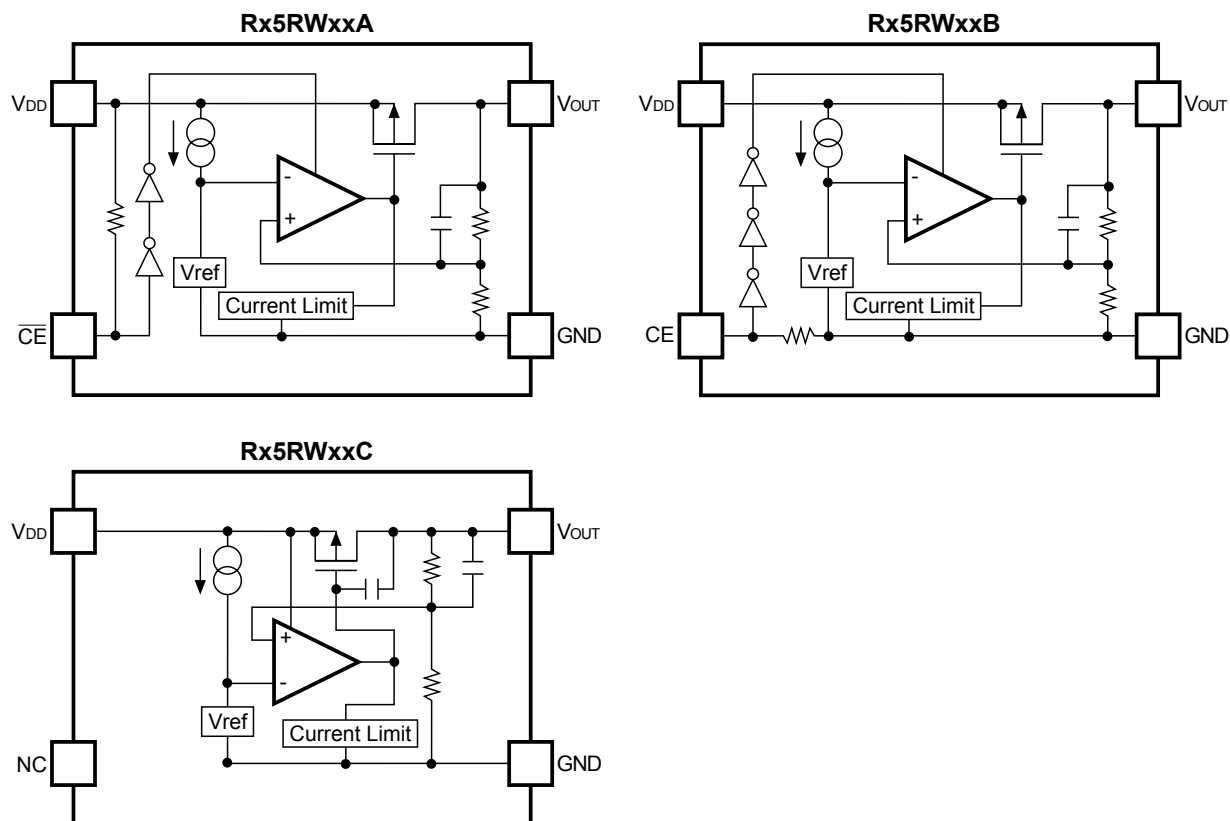

## SELECTION GUIDE

The output voltage, the active type, and the packing type for the ICs can be selected at the user's request. The selection can be made with designating the part number as shown below:

Rx5RWxxxx-xx ←Part Number  
 ↑           ↑ ↑ ↑ ↑  
 a           b c d e

Code	Contents
a	Designation of Package Type Q: SC-82AB D:SON1612-6
b	Setting Output Voltage (V <sub>OUT</sub> ): Stepwise setting with a step of 0.1V in the range of 1.5V to 6.0V is possible.
c	Designation of Chip enable Active Type: A: "L" active type B: "H" active type C: no chip enable type
d	Designation of Packing Type: A: Taping B: Antistatic bag (for Sample only)
e	Designation of Taping Type: TR (refer to Taping Specifications)

## PIN CONFIGURATION

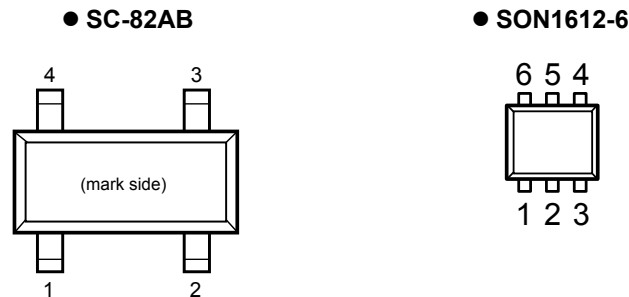

## PIN DESCRIPTION

### ● SC-82AB

Pin No	Symbol	Pin Description
1	GND	Ground Pin
2	V <sub>DD</sub>	Input Pin
3	V <sub>OUT</sub>	Output Pin
4	$\overline{\text{CE}}$ or CE or NC	Chip Enable Pin or No Connection

### SON1612-6

Pin No	Symbol	Pin Description
1	$\overline{\text{CE}}$ or CE or NC	Chip Enable Pin or No Connection
2	V <sub>DD</sub>	Input Pin
3	V <sub>OUT</sub>	Output Pin
4	NC	No Connection
5	V <sub>DD</sub>	Input Pin
6	GND	Ground Pin

## ABSOLUTE MAXIMUM RATINGS

Symbol	Item	Rating	Unit
V <sub>IN</sub>	Input Voltage	9.0	V
V <sub>CE</sub>	Input Voltage for $\overline{\text{CE}}$ /CE Pin	-0.3 to V <sub>IN</sub> +0.3	V
V <sub>OUT</sub>	Output Voltage	-0.3 to V <sub>IN</sub> +0.3	V
I <sub>OUT</sub>	Output Current	150	mA
P <sub>D</sub>	Power Dissipation (SC-82AB) *1	380	mW
	Power Dissipation (SON1612-6) *1	500	
T <sub>opt</sub>	Operating Temperature	-40 to +85	°C
T <sub>stg</sub>	Storage Temperature	-55 to +125	°C

\*1 ) For Power Dissipation, please refer to PACKAGE INFORMATION to be described.

### ABSOLUTE MAXIMUM RATINGS

Absolute Maximum ratings are threshold limit values that must not be exceeded even for an instant under any conditions. Moreover, such values for any two items must not be reached simultaneously. Operation above these absolute maximum ratings may cause degradation or permanent damage to the device. These are stress ratings only and do not necessarily imply functional operation below these limits.

## ELECTRICAL CHARACTERISTICS

## • Rx5RW30A

T<sub>opt</sub>=25°C

Symbol	Item	Conditions	Min.	Typ.	Max.	Unit
V <sub>OUT</sub>	Output Voltage	V <sub>IN</sub> =5.0V 10μA ≤ I <sub>OUT</sub> ≤ 10mA	2.940	3.000	3.060	V
I <sub>OUT</sub>	Output Current	V <sub>IN</sub> =5.0V	50			mA
ΔV <sub>OUT</sub> /ΔI <sub>OUT</sub>	Load Regulation	V <sub>IN</sub> =5.0V, 1mA ≤ I <sub>OUT</sub> ≤ 50mA		40	60	mV
V <sub>DIF</sub>	Dropout Voltage	I <sub>OUT</sub> =1mA		40	60	mV
I <sub>SS</sub>	Supply Current	V <sub>IN</sub> =5.0V		1.5	3.0	μA
I <sub>standby</sub>	Standby Current	V <sub>IN</sub> =5.0V, V <sub>CE</sub> =5.0V		0.1	1.0	μA
ΔV <sub>OUT</sub> /ΔV <sub>IN</sub>	Line Regulation	I <sub>OUT</sub> =1mA V <sub>OUT</sub> +0.5V ≤ V <sub>IN</sub> ≤ 8V	0.00	0.05	0.20	%/V
V <sub>IN</sub>	Input Voltage				8.0	V
ΔV <sub>OUT</sub> /ΔT <sub>opt</sub>	Output Voltage Temperature Coefficient	I <sub>OUT</sub> =10mA -40°C ≤ T <sub>opt</sub> ≤ 85°C		±100		ppm/ °C
I <sub>LIM</sub>	Short Current Limit	V <sub>OUT</sub> =0V		40		mA
R <sub>PU</sub>	Pull up resistance for CE pin		1.5	4.0	12.0	MΩ
V <sub>CEH</sub>	$\overline{\text{CE}}$ Input Voltage "H"		1.5			V
V <sub>CEL</sub>	$\overline{\text{CE}}$ Input Voltage "L"		0.25			V

- Rx5RW30B

T<sub>opt</sub>=25°C

Symbol	Item	Conditions	Min.	Typ.	Max.	Unit
V <sub>OUT</sub>	Output Voltage	V <sub>IN</sub> =5.0V 10μA ≤ I <sub>OUT</sub> ≤ 10mA	2.940	3.000	3.060	V
I <sub>OUT</sub>	Output Current	V <sub>IN</sub> =5.0V	50			mA
ΔV <sub>OUT</sub> /ΔI <sub>OUT</sub>	Load Regulation	V <sub>IN</sub> =5.0V 1mA ≤ I <sub>OUT</sub> ≤ 50mA		40	60	mV
V <sub>DIF</sub>	Dropout Voltage	I <sub>OUT</sub> =1mA		40	60	mV
I <sub>SS</sub>	Supply Current	V <sub>IN</sub> =5.0V		1.5	3.0	μA
I <sub>standby</sub>	Standby Current	V <sub>IN</sub> =5.0V, V <sub>CE</sub> =GND		0.1	1.0	μA
ΔV <sub>OUT</sub> /ΔV <sub>IN</sub>	Line Regulation	I <sub>OUT</sub> =1mA V <sub>OUT</sub> +0.5V ≤ V <sub>IN</sub> ≤ 8V	0.00	0.05	0.20	%/V
V <sub>IN</sub>	Input Voltage				8.0	V
ΔV <sub>OUT</sub> /ΔT <sub>opt</sub>	Output Voltage Temperature Coefficient	I <sub>OUT</sub> =1mA -40°C ≤ T <sub>opt</sub> ≤ 85°C		±100		ppm/ °C
I <sub>LIM</sub>	Short Current Limit	V <sub>OUT</sub> =0V		40		mA
R <sub>PD</sub>	Pull down resistance for CE pin		1.5	4.0	12.0	MΩ
V <sub>CEH</sub>	CE Input Voltage "H"		1.5			V
V <sub>CEL</sub>	CE Input Voltage "L"		0.25			V

- Rx5RW30C

T<sub>opt</sub>=25°C

Symbol	Item	Conditions	Min.	Tyo.	Max.	Unit
V <sub>OUT</sub>	Output Voltage	V <sub>IN</sub> =5.0V 10μA ≤ I <sub>OUT</sub> ≤ 10mA	2.940	3.000	3.060	V
I <sub>OUT</sub>	Output Current	V <sub>IN</sub> =5.0V	50			mA
ΔV <sub>OUT</sub> /ΔI <sub>OUT</sub>	Load Regulation	V <sub>IN</sub> =5.0V 1mA ≤ I <sub>OUT</sub> ≤ 50mA		40	60	mV
V <sub>DIF</sub>	Dropout Voltage	I <sub>OUT</sub> =1mA		40	60	mV
I <sub>SS</sub>	Supply Current	V <sub>IN</sub> =5.0V		1.5	3.0	μA
ΔV <sub>OUT</sub> /ΔV <sub>IN</sub>	Line Regulation	I <sub>OUT</sub> =1mA 3.5V ≤ V <sub>IN</sub> ≤ 8.0V	0.00	0.05	0.20	%/V
V <sub>IN</sub>	Input Voltage				8.0	V
ΔV <sub>OUT</sub> /ΔT <sub>opt</sub>	Output Voltage Temperature Coefficient	I <sub>OUT</sub> =10mA -40°C ≤ T <sub>opt</sub> ≤ 85°C		±100		ppm/ °C
I <sub>LIM</sub>	Short Current Limit			40		mA

## ELECTRICAL CHARACTERISTICS BY OUTPUT VOLTAGE

T<sub>opt</sub>=25°C

Part Number	Output Voltage			Output Current			Load Regulation			Dropout Voltage									
	Condi- tions	V <sub>OUT</sub> (V)		I <sub>OUT</sub> (mA)		ΔV <sub>OUT</sub> /ΔI <sub>OUT</sub> (mV)			V <sub>DIF</sub> (mV)										
		Min.	Typ.	Max.	Condi- tions	Min.	Typ.	Condi- tions	Typ.	Max.	Condi- tions	Typ.	Max.						
Rx5RW15	V <sub>IN</sub> -V <sub>OUT</sub> =2.0V 10μA ≤ I <sub>OUT</sub> ≤ 10mA	1.470	1.500	1.530	V <sub>IN</sub> -V <sub>OUT</sub> =2.0V	35		V <sub>IN</sub> -V <sub>OUT</sub> =2.0V 1mA ≤ I <sub>OUT</sub> ≤ 35mA	30	45	I <sub>OUT</sub> = 1mA	120	200						
Rx5RW16		1.568	1.600	1.632								90	135						
Rx5RW17		1.666	1.700	1.734								60	90						
Rx5RW18		1.764	1.800	1.836								50	75						
Rx5RW19		1.862	1.900	1.938								40	60						
Rx5RW20		1.960	2.000	2.040								35	55						
Rx5RW21		2.058	2.100	2.142								50		V <sub>IN</sub> -V <sub>OUT</sub> =2.0V 1mA ≤ I <sub>OUT</sub> ≤ 50mA	40	60	I <sub>OUT</sub> = 1mA	30	45
Rx5RW22		2.156	2.200	2.244														35	55
Rx5RW23		2.254	2.300	2.346														30	45
Rx5RW24		2.352	2.400	2.448														25	40
Rx5RW25		2.450	2.500	2.550														20	35
Rx5RW26		2.548	2.600	2.652														15	30
Rx5RW27		2.646	2.700	2.754														10	25
Rx5RW28		2.744	2.800	2.856														5	20
Rx5RW29		2.842	2.900	2.958														5	20
Rx5RW30		2.940	3.000	3.060		5	20												
Rx5RW31		3.038	3.100	3.162		5	20												
Rx5RW32		3.136	3.200	3.264		5	20												
Rx5RW33		3.234	3.300	3.366		5	20												
Rx5RW34		3.332	3.400	3.468		5	20												
Rx5RW35		3.430	3.500	3.570		5	20												
Rx5RW36		3.528	3.600	3.672		5	20												
Rx5RW37		3.626	3.700	3.774		5	20												
Rx5RW38		3.724	3.800	3.876		5	20												
Rx5RW39		3.822	3.900	3.978		5	20												
Rx5RW40		3.920	4.000	4.080		5	20												
Rx5RW41		4.018	4.100	4.182		5	20												
Rx5RW42		4.116	4.200	4.284		5	20												
Rx5RW43		4.214	4.300	4.386		5	20												
Rx5RW44		4.312	4.400	4.488		5	20												
Rx5RW45		4.410	4.500	4.590		5	20												
Rx5RW46		4.508	4.600	4.692		5	20												
Rx5RW47		4.606	4.700	4.794		5	20												
Rx5RW48		4.704	4.800	4.896		5	20												
Rx5RW49		4.802	4.900	4.998		5	20												
Rx5RW50		4.900	5.000	5.100		5	20												
Rx5RW51		4.998	5.100	5.202		5	20												
Rx5RW52		5.096	5.200	5.304		5	20												
Rx5RW53		5.194	5.300	5.406		5	20												
Rx5RW54		5.292	5.400	5.508		5	20												
Rx5RW55		5.390	5.500	5.610		5	20												
Rx5RW56		5.488	5.600	5.712		5	20												
Rx5RW57		5.586	5.700	5.814		5	20												
Rx5RW58		5.684	5.800	5.916		5	20												
Rx5RW59		5.782	5.900	6.018		5	20												
Rx5RW60		5.880	6.000	6.120		5	20												

## ELECTRICAL CHARACTERISTICS BY OUTPUT VOLTAGE

(common characteristics)

$T_{opt}=25^{\circ}\text{C}$

Symbol	Item	Conditions	Min.	Typ.	Max.	Unit
$I_{SS}$	Supply Current	$V_{IN}=\text{set}V_{OUT}+2.0$		1.5	3.0	$\mu\text{A}$
$I_{standby}$	Standby Current	$V_{IN}=\text{set}V_{OUT}+2.0\text{V}$ $V_{CE}=V_{IN}$ (Rx5RWxxA), $V_{CE}=\text{GND}$ (Rx5RWxxB)		0.1	1.0	$\mu\text{A}$
$\Delta V_{OUT}/\Delta V_{IN}$	Line Regulation	$I_{OUT}=1\text{mA}$ $\text{set}V_{OUT}+0.5\text{V} \leq V_{IN} \leq 8\text{V}$	0.00	0.05	0.20	$\%/V$
$V_{IN}$	Input Voltage				8.0	V
$\Delta V_{OUT}/\Delta T_{opt}$	Output Voltage Temperature Coefficient	$I_{OUT}=10\text{mA}$ $-40^{\circ}\text{C} \leq T_{opt} \leq 85^{\circ}\text{C}$		$\pm 100$		ppm/ $^{\circ}\text{C}$
$I_{LIM}$	Short Current Limit	$V_{OUT}=0\text{V}$		40		mA
$R_{PU}/R_{PD}$	$\overline{\text{CE}}$ Pull-up / CE Pull-down Resistance	applied to A/B version	1.5	4.0	12.0	$\text{M}\Omega$
$V_{CEH}$	$\overline{\text{CE}}$ /CE Input Voltage "H"	applied to A/B version	1.5			V
$V_{CEL}$	$\overline{\text{CE}}$ /CE Input Voltage "L"	applied to A/B version			0.25	V

## OPERATION

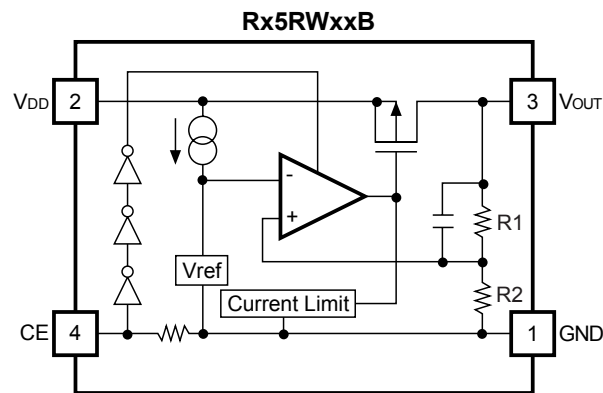

In these ICs, output voltage  $V_{OUT}$  is detected by Feedback Registers R1, R2, and the detected output voltage is compared with a reference voltage by the error amplifier, so that a constant voltage is output.

A current limit circuit working for short protect, and a chip enable circuit are included.

### TEST CIRCUITS

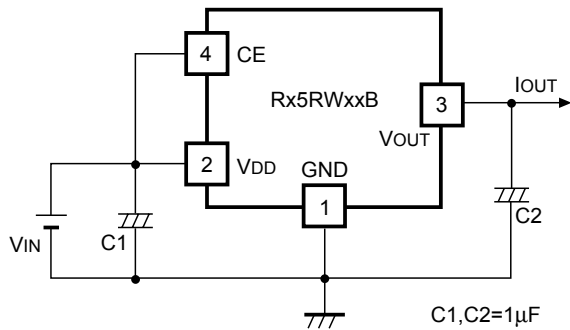

Standard Test Circuit

C1,C2=1 $\mu$ F

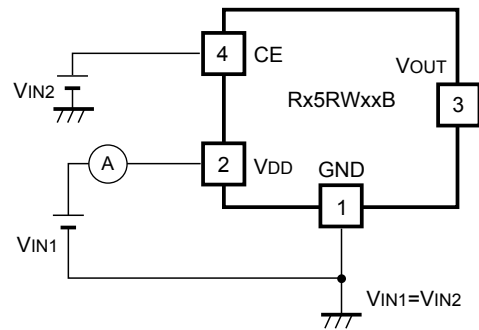

Test Circuit for Supply Current

VIN1=VIN2

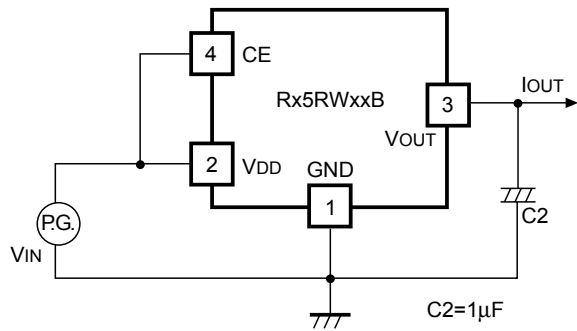

Test Circuit for Ripple Rejection and Line Transient Response

C2=1 $\mu$ F

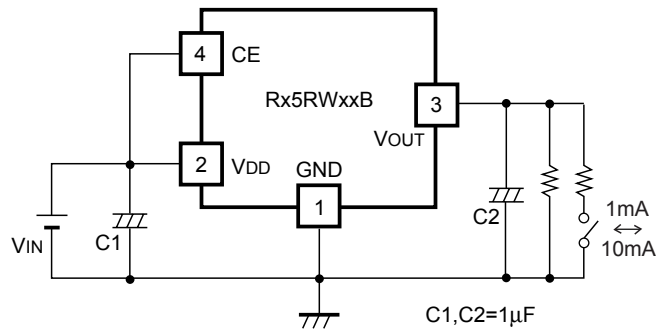

Test Circuit for Load Transient Response

C1,C2=1 $\mu$ F



## TYPICAL APPLICATION

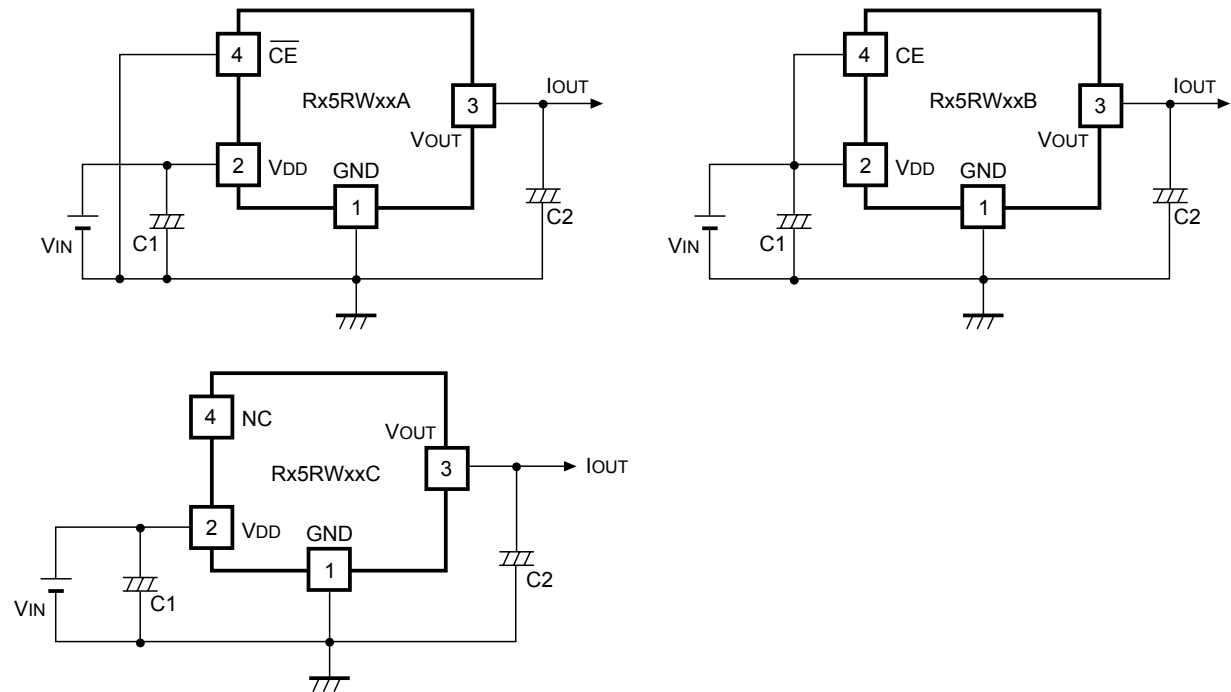

In Rx5RW Series, a constant voltage can be obtained without using capacitors, C1 and C2. However, when the wire connected  $V_{IN}$  is long, use capacitor C1. Output noise can be reduced with using capacitor 2.

Insert capacitors C1 and C2 with the capacitance of  $0.1\mu\text{F}$  to  $2\mu\text{F}$  between input/output pins and GND pin with minimum wiring.

## TYPICAL CHARACTERISTICS

### 1) Output Voltage vs. Output Current

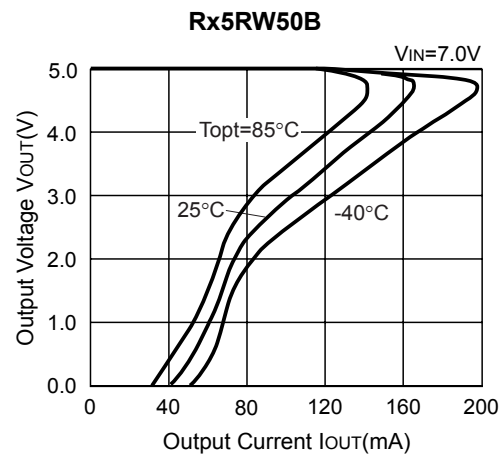
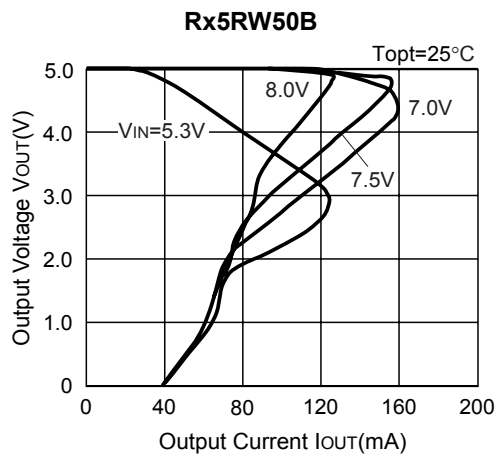
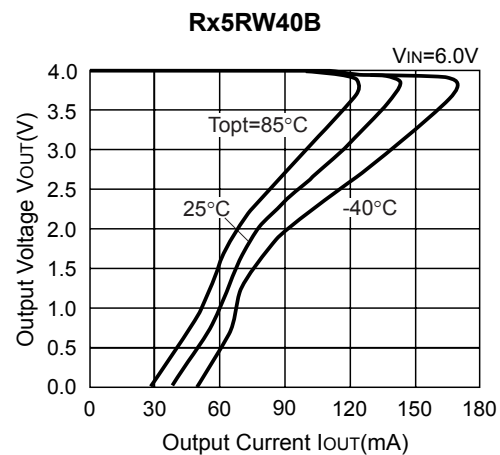
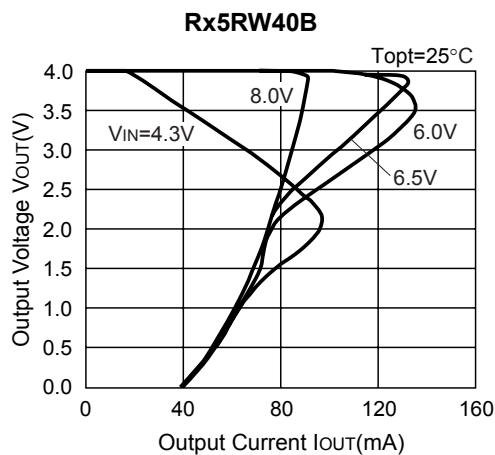
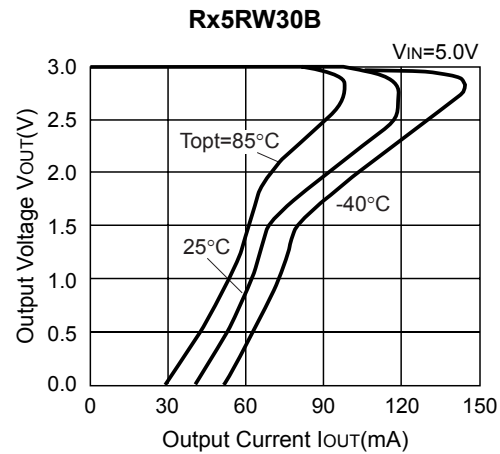
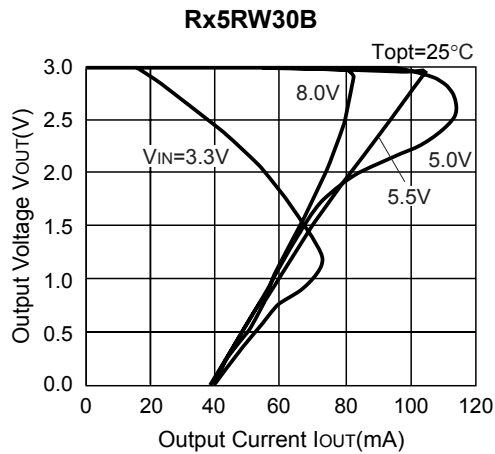

2) Output Voltage vs. Input Voltage

**Rx5RW30B**

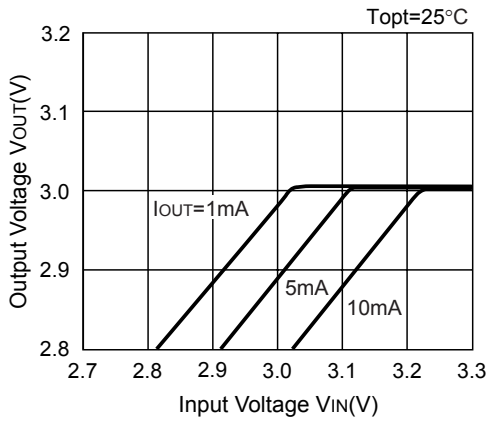

**Rx5RW30B**

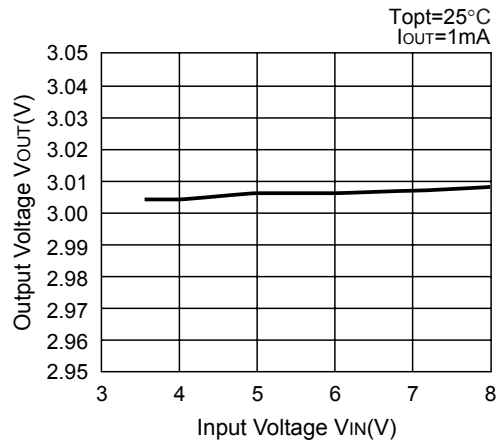

**Rx5RW40B**

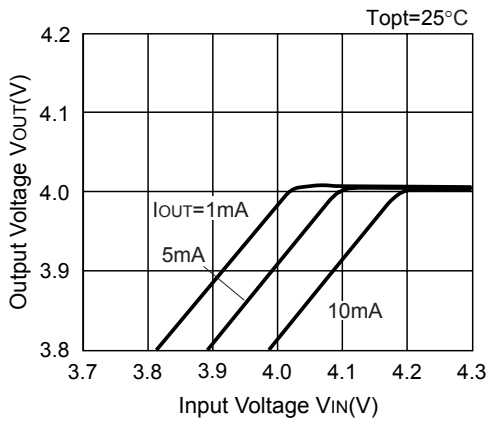

**Rx5RW40B**

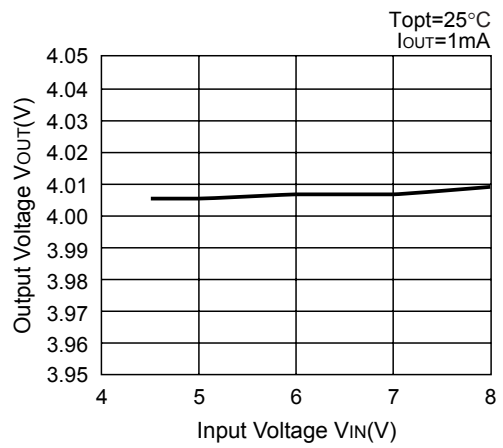

**Rx5RW50B**

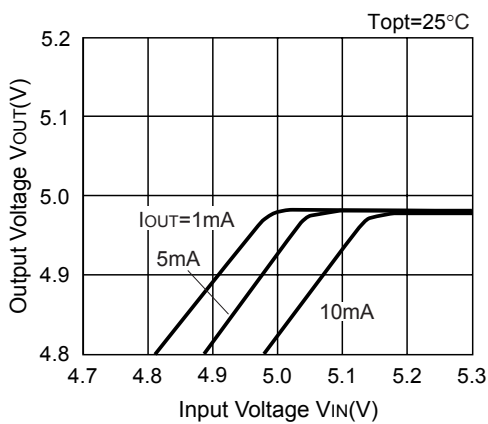

**Rx5RW50B**

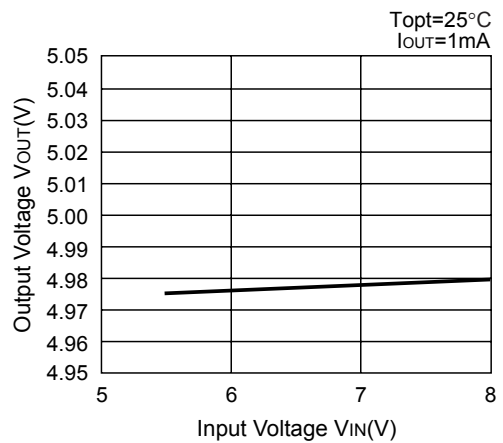

3) Dropout Voltage vs. Output Current

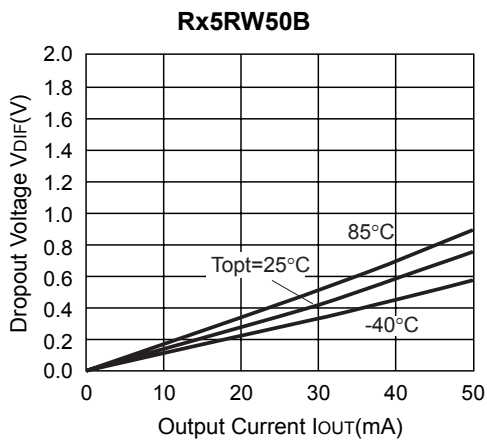
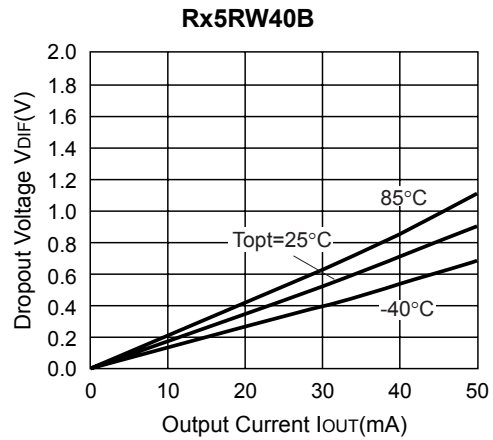
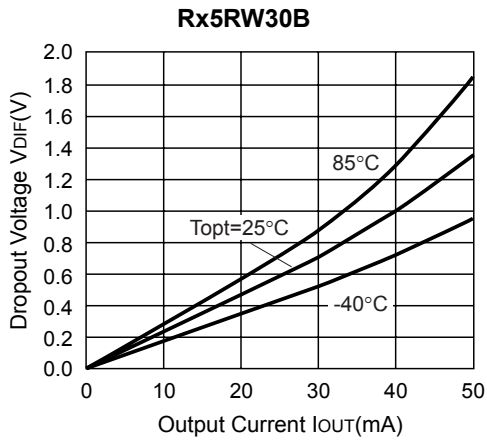

4) Output Voltage vs. Temperature

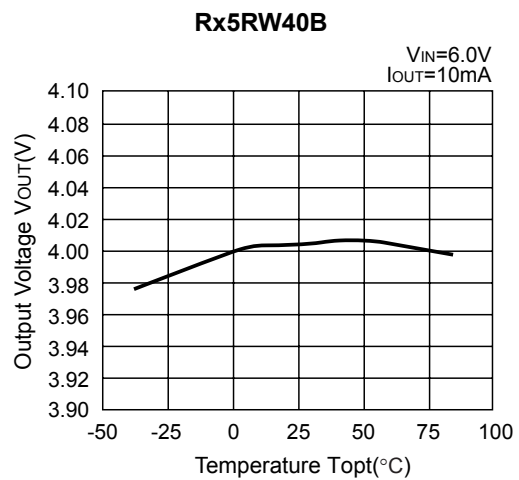
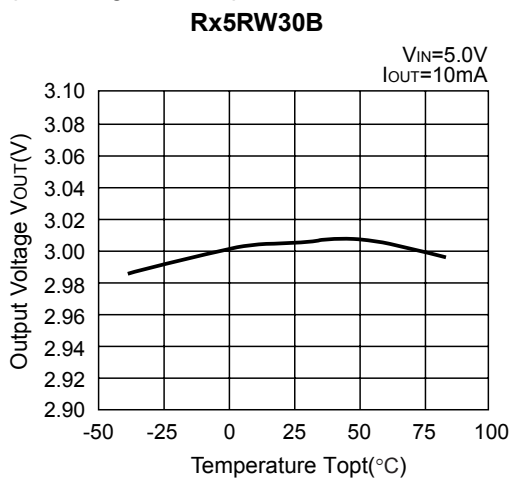

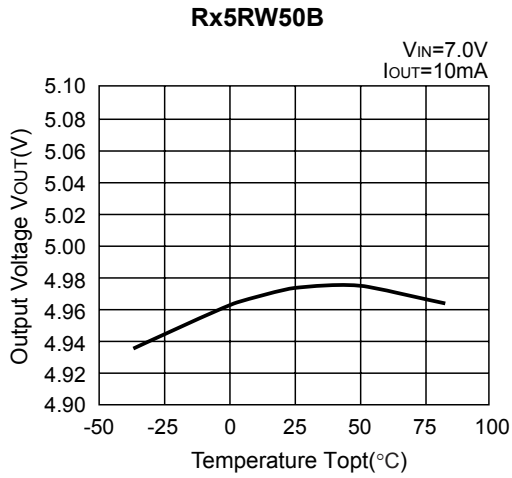

5) Supply Current vs. Input Voltage

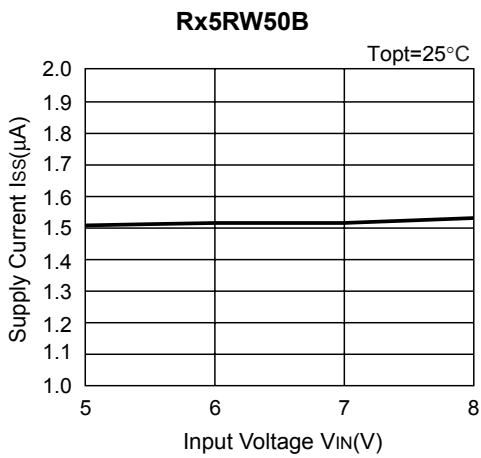
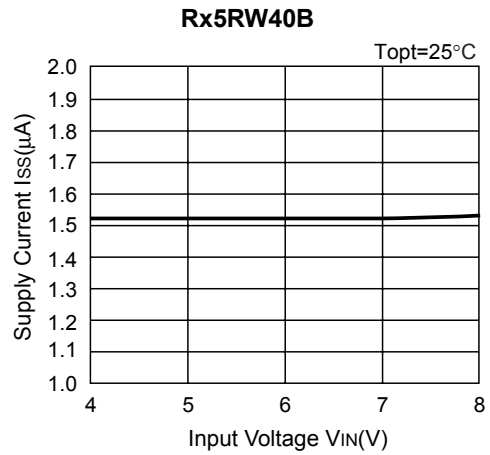
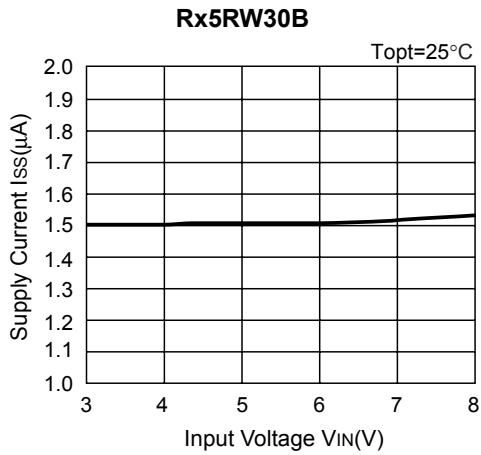

## Rx5RW

### 6) Supply Current vs. Temperature

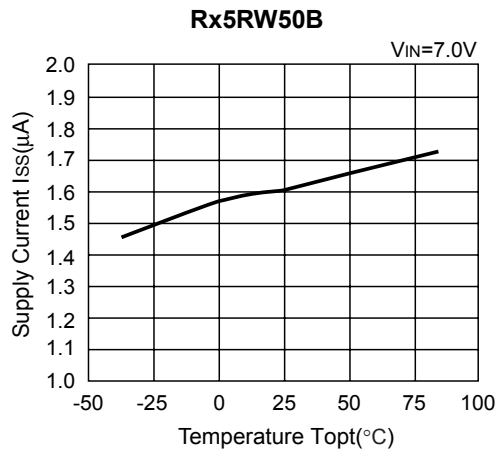
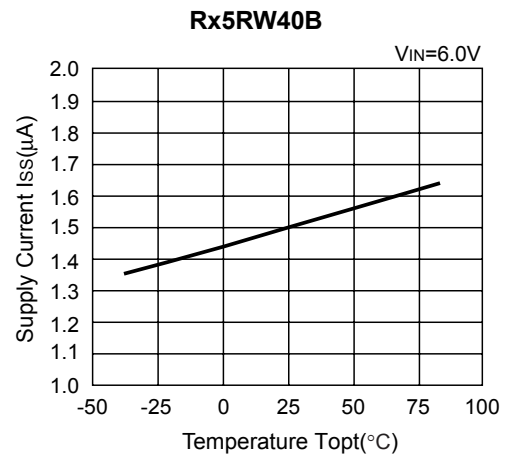
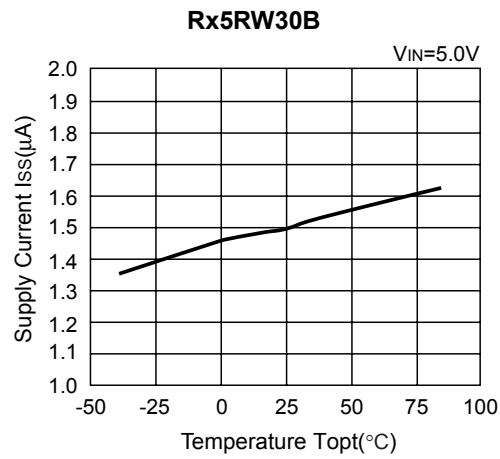

### 7) Dropout Voltage vs. Set Output Voltage

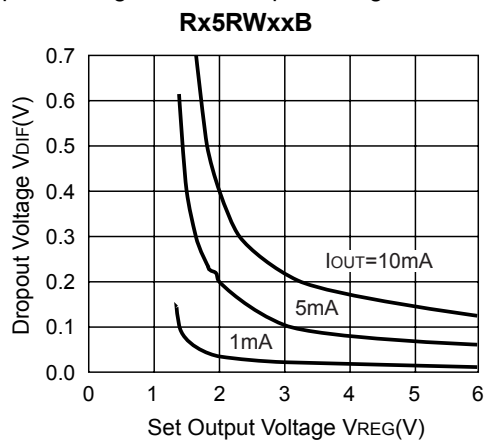

8) Line Transient Response

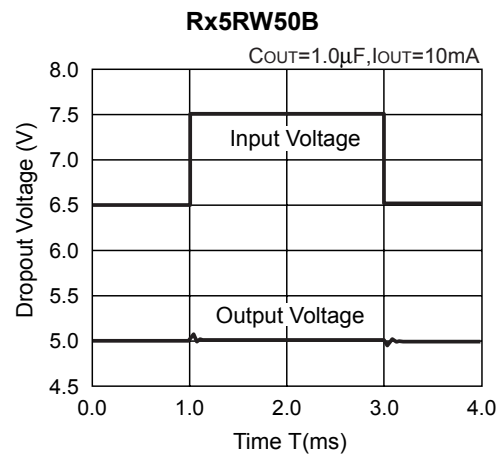
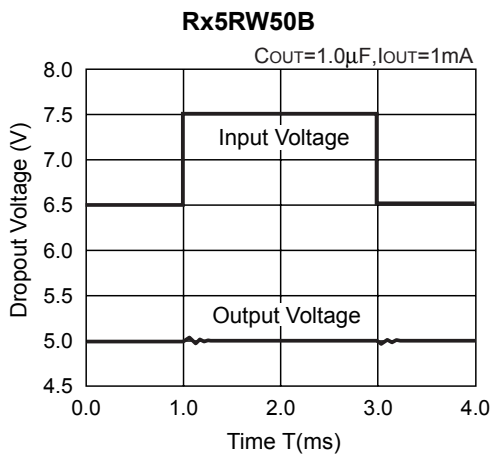
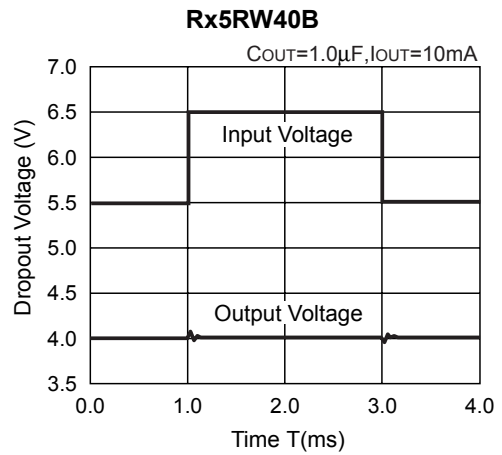
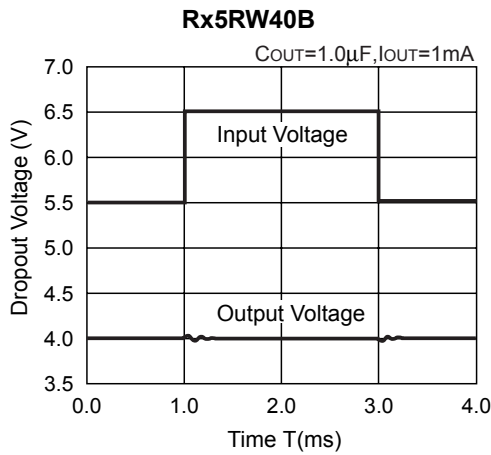
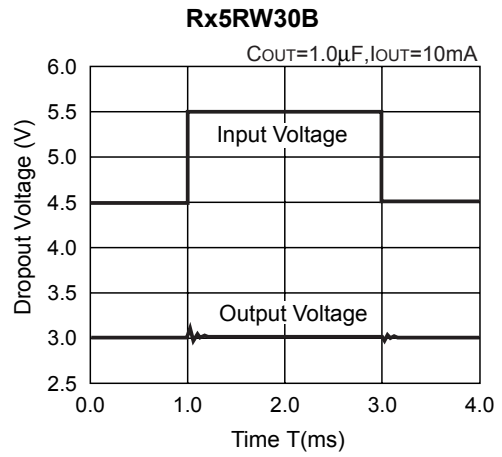
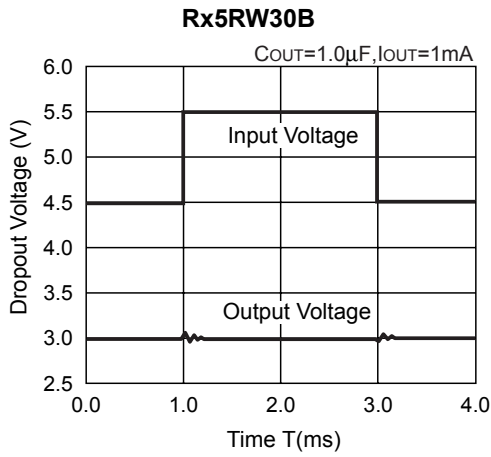

9) Load Transient Response

Rx5RW30B

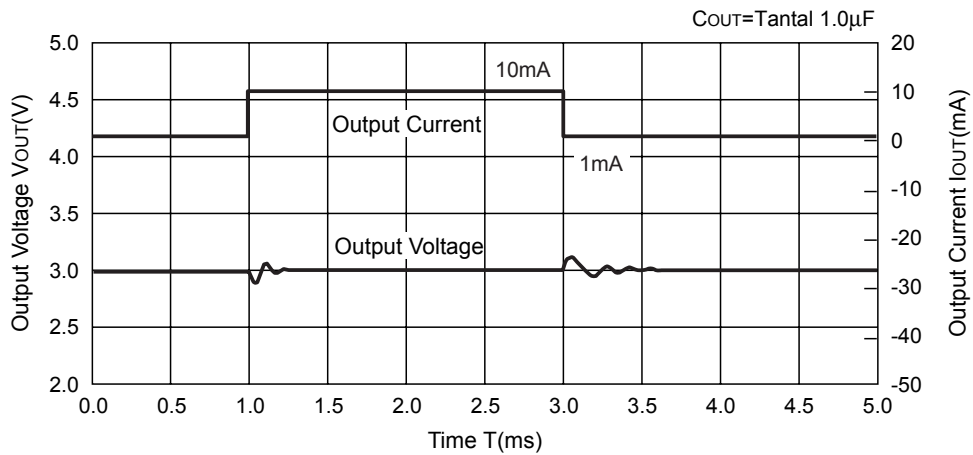

Rx5RW40B

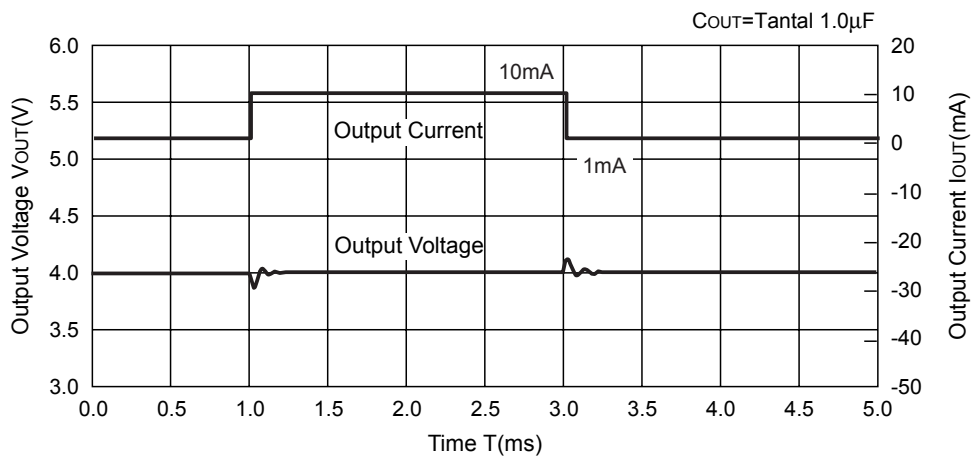

Rx5RW50B

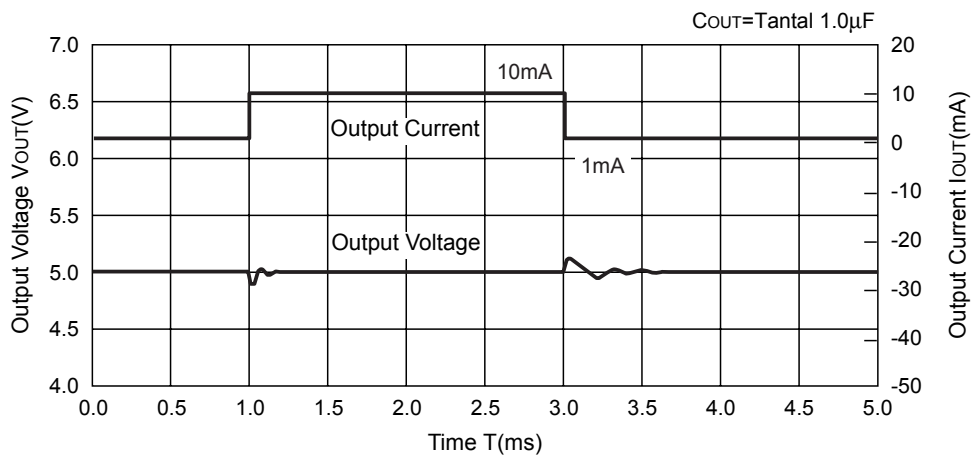



10) Ripple Rejection

**Rx5RW30B**

$V_{IN}=5V_{dc}+0.5V_{p-p}$   
 $I_{OUT}=10mA$   
 $C_{OUT}=1\mu F$

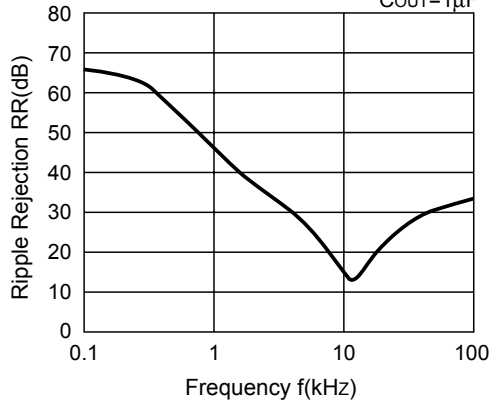

**Rx5RW40B**

$V_{IN}=6V_{dc}+0.5V_{p-p}$   
 $I_{OUT}=10mA$   
 $C_{OUT}=1\mu F$

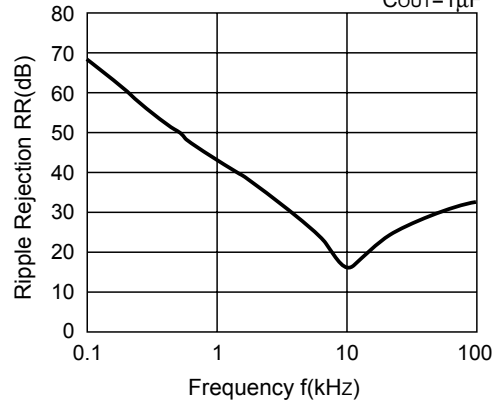

**Rx5RW50B**

$V_{IN}=7V_{dc}+0.5V_{p-p}$   
 $I_{OUT}=10mA$   
 $C_{OUT}=1\mu F$

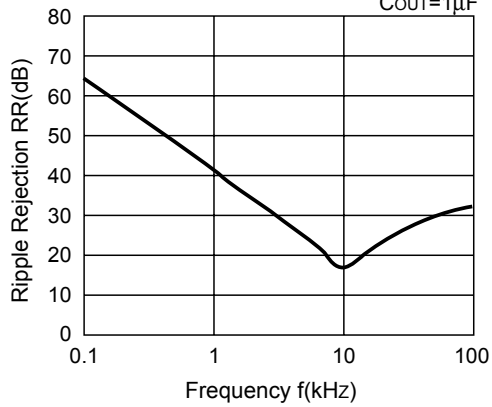

• SC-82AB

Unit: mm

PACKAGE DIMENSIONS

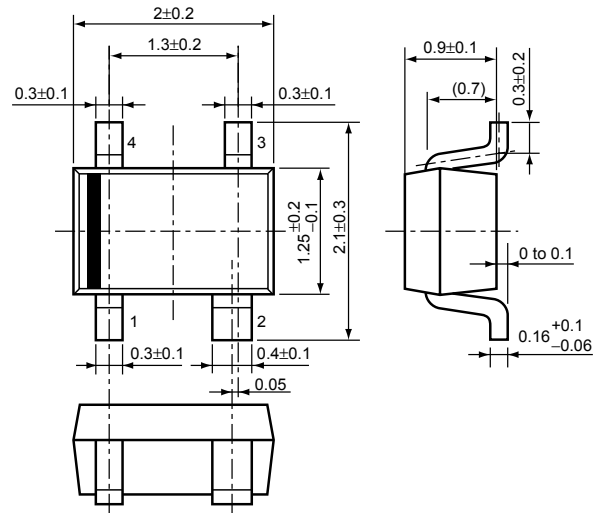

TAPING SPECIFICATION

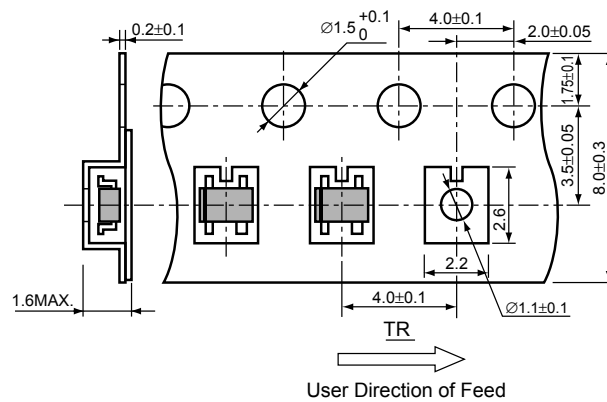

TAPING REEL DIMENSIONS

(1reel=3000pcs)

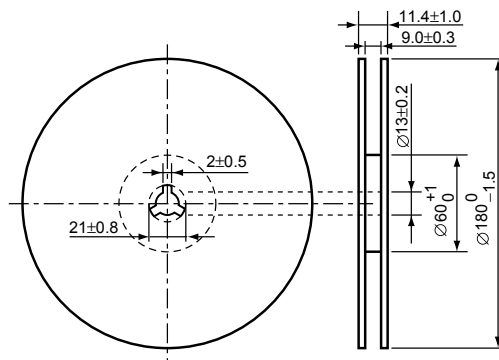

### POWER DISSIPATION (SC-82AB)

This specification is at mounted on board. Power Dissipation ( $P_D$ ) depends on conditions of mounting on board. This specification is based on the measurement at the condition below:

Measurement Conditions

	Standard Land Pattern
Environment	Mounting on Board (Wind velocity=0m/s)
Board Material	Glass cloth epoxy plactic (Double sided)
Board Dimensions	40mm × 40mm × 1.6mm
Copper Ratio	Top side : Approx. 50% , Back side : Approx. 50%
Through-hole	φ0.5mm × 44pcs

Measurement Result

( $T_{opt}=25^{\circ}C, T_{jmax}=125^{\circ}C$ )

	Standard Land Pattern	Free Air
Power Dissipation	380mW	150mW
Thermal Resistance	$\theta_{ja}=(125-25^{\circ}C)/0.38W=263^{\circ}C/W$	667 $^{\circ}C/W$

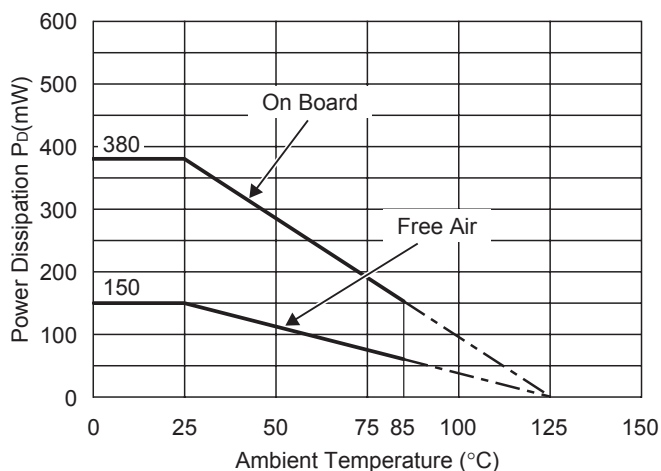

Power Dissipation

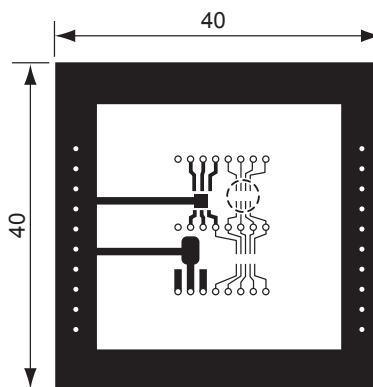

Measurement Board Pattern

○ IC Mount Area (Unit : mm)

### RECOMMENDED LAND PATTERN

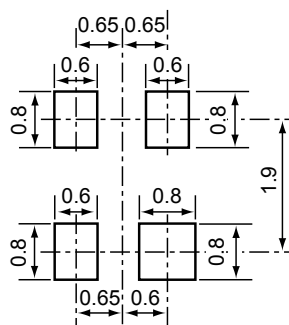

(Unit: mm)

• SON1612-6

Unit: mm

PACKAGE DIMENSIONS

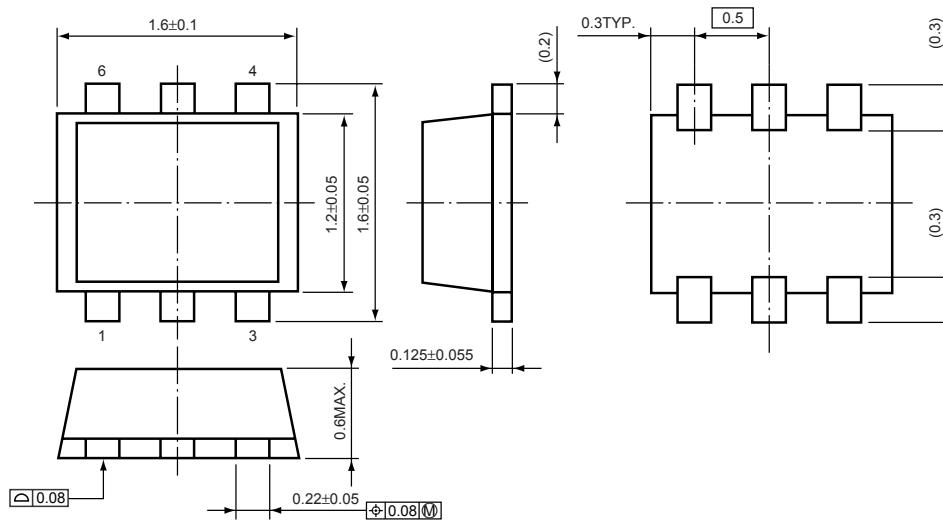

TAPING SPECIFICATION

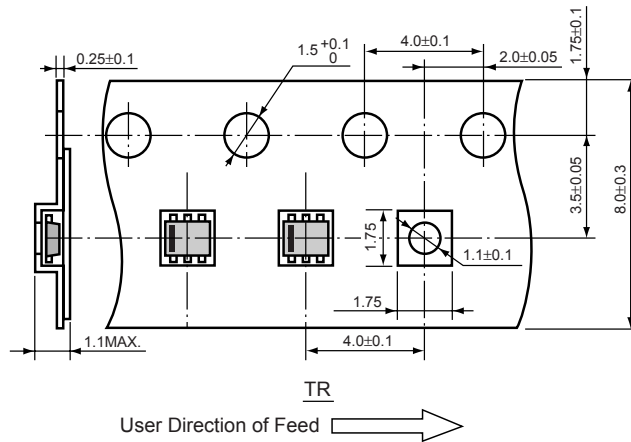

TAPING REEL DIMENSIONS

(1reel=4000pcs)

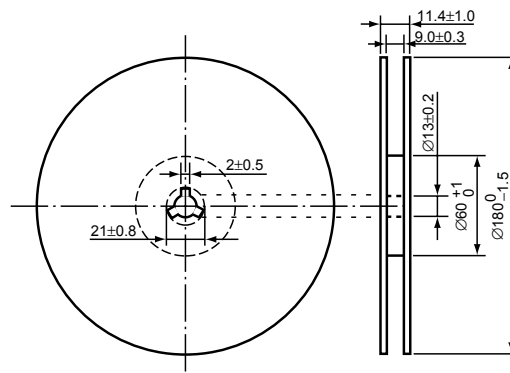

### Power Dissipation (SON1612-6)

This specification is at mounted on board.

Power Dissipation ( $P_D$ ) depends on conditions of mounting on board. This specification is based on the measurement at the condition below:

Measurement Conditions

	Standard Land Pattern
Environment	Mounting on Board (Wind velocity=0m/s)
Board Material	Glass cloth epoxy plactic (Double sided)
Board Dimensions	40mm × 40mm × 1.6mm
Copper Ratio	Top side : Approx. 50%, Back side : Approx.50%
Through-hole	φ0.5mm × 24pcs

Measurement Result

( $T_{opt}=25^{\circ}C, T_{jmax}=125^{\circ}C$ )

	Standard Land Pattern
Power Dissipation	500mW
Thermal Resistance	$\theta_{ja}=(125-25^{\circ}C)/0.5W=200^{\circ}C/W$

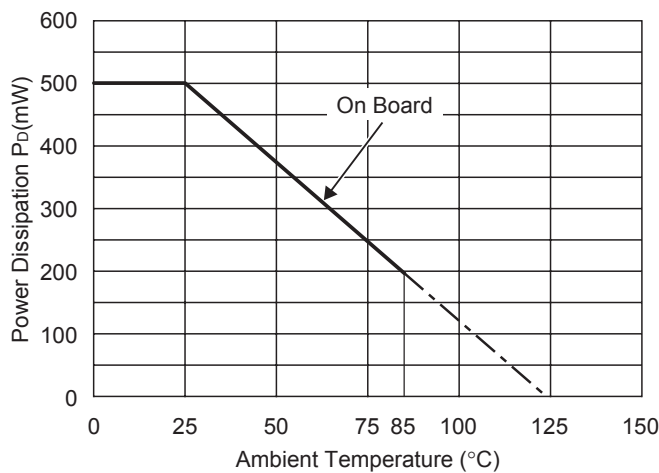

Power Dissipation

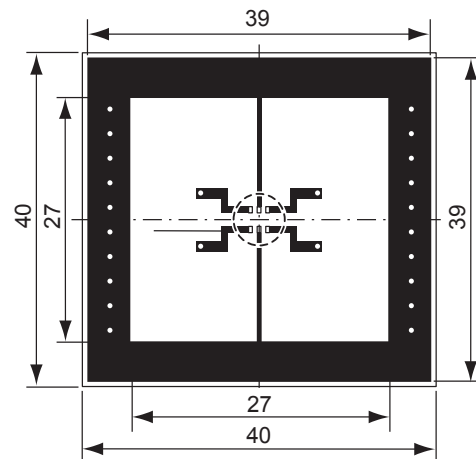

Measurement Board Pattern

○ IC Mount Area Unit : mm

### RECOMMENDED LAND PATTERN

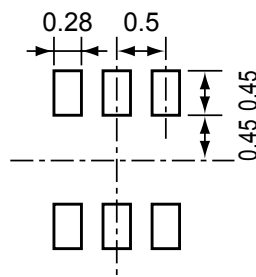

(Unit: mm)

RQ5RW SERIES MARK SPECIFICATION

● SC-82AB

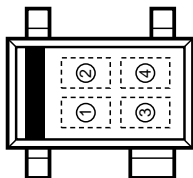

①, ② : Product Code (refer to Part Number vs. Product Code)

③, ④ : Lot Number

● Part Number vs. Product Code

Part Number	Product Code	
	①	②
RQ5RW20AA	2	A
RQ5RW21AA	2	B
RQ5RW22AA	2	C
RQ5RW23AA	2	D
RQ5RW24AA	2	E
RQ5RW25AA	2	F
RQ5RW26AA	2	G
RQ5RW27AA	2	H
RQ5RW28AA	2	J
RQ5RW29AA	2	K
RQ5RW30AA	3	A
RQ5RW31AA	3	B
RQ5RW32AA	3	C
RQ5RW33AA	3	D
RQ5RW34AA	3	E
RQ5RW35AA	3	F
RQ5RW36AA	3	G
RQ5RW37AA	3	H
RQ5RW38AA	3	J
RQ5RW39AA	3	K
RQ5RW40AA	4	A
RQ5RW41AA	4	B
RQ5RW42AA	4	C
RQ5RW43AA	4	D
RQ5RW44AA	4	E
RQ5RW45AA	4	F
RQ5RW46AA	4	G
RQ5RW47AA	4	H
RQ5RW48AA	4	J
RQ5RW49AA	4	K
RQ5RW50AA	5	A
RQ5RW51AA	5	B
RQ5RW52AA	5	C
RQ5RW53AA	5	D

Part Number	Product Code	
	①	②
RQ5RW54AA	5	E
RQ5RW55AA	5	F
RQ5RW56AA	5	G
RQ5RW57AA	5	H
RQ5RW58AA	5	J
RQ5RW59AA	5	K
RQ5RW60AA	6	A
RQ5RW19AA	6	B
RQ5RW18AA	6	C
RQ5RW17AA	6	D
RQ5RW16AA	6	E
RQ5RW15AA	6	F
RQ5RW20BA	7	A
RQ5RW21BA	7	B
RQ5RW22BA	7	C
RQ5RW23BA	7	D
RQ5RW24BA	7	E
RQ5RW25BA	7	F
RQ5RW26BA	7	G
RQ5RW27BA	7	H
RQ5RW28BA	7	J
RQ5RW29BA	7	K
RQ5RW30BA	8	A
RQ5RW31BA	8	B
RQ5RW32BA	8	C
RQ5RW33BA	8	D
RQ5RW34BA	8	E
RQ5RW35BA	8	F
RQ5RW36BA	8	G
RQ5RW37BA	8	H
RQ5RW38BA	8	J
RQ5RW39BA	8	K
RQ5RW40BA	9	A
RQ5RW41BA	9	B

Part Number	Product Code	
	①	②
RQ5RW42BA	9	C
RQ5RW43BA	9	D
RQ5RW44BA	9	E
RQ5RW45BA	9	F
RQ5RW46BA	9	G
RQ5RW47BA	9	H
RQ5RW48BA	9	J
RQ5RW49BA	9	K
RQ5RW50BA	0	A
RQ5RW51BA	0	B
RQ5RW52BA	0	C
RQ5RW53BA	0	D
RQ5RW54BA	0	E
RQ5RW55BA	0	F
RQ5RW56BA	0	G
RQ5RW57BA	0	H
RQ5RW58BA	0	J
RQ5RW59BA	0	K
RQ5RW60BA	1	A
RQ5RW19BA	1	B
RQ5RW18BA	1	C
RQ5RW17BA	1	D
RQ5RW16BA	1	E
RQ5RW15BA	1	F
RQ5RW20CA	2	L
RQ5RW21CA	2	M
RQ5RW22CA	2	N
RQ5RW23CA	2	P
RQ5RW24CA	2	R
RQ5RW25CA	2	S
RQ5RW26CA	2	T
RQ5RW27CA	2	U
RQ5RW28CA	2	V
RQ5RW29CA	2	W

Part Number	Product Code	
	①	②
RQ5RW30CA	3	L
RQ5RW31CA	3	M
RQ5RW32CA	3	N
RQ5RW33CA	3	P
RQ5RW34CA	3	R
RQ5RW35CA	3	S
RQ5RW36CA	3	T
RQ5RW37CA	3	U
RQ5RW38CA	3	V
RQ5RW39CA	3	W
RQ5RW40CA	4	L
RQ5RW41CA	4	M
RQ5RW42CA	4	N
RQ5RW43CA	4	P
RQ5RW44CA	4	R
RQ5RW45CA	4	S
RQ5RW46CA	4	T
RQ5RW47CA	4	U
RQ5RW48CA	4	V
RQ5RW49CA	4	W
RQ5RW50CA	5	L
RQ5RW51CA	5	M
RQ5RW52CA	5	N
RQ5RW53CA	5	P
RQ5RW54CA	5	R
RQ5RW55CA	5	S
RQ5RW56CA	5	T
RQ5RW57CA	5	U
RQ5RW58CA	5	V
RQ5RW59CA	5	W
RQ5RW60CA	6	L
RQ5RW19CA	6	M
RQ5RW18CA	6	N
RQ5RW17CA	6	P
RQ5RW16CA	6	S

## RD5RW SERIES MARK SPECIFICATION

● SON1612-6

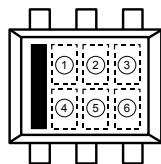

①~④ : Product Code (refer to Part Number vs. Product Code)

⑤, ⑥ : Lot Number

● Part Number vs. Product Code

Part Number	Product Code			
	①	②	③	④
RD5RW15AA	E	1	5	A
RD5RW16AA	E	1	6	A
RD5RW17AA	E	1	7	A
RD5RW18AA	E	1	8	A
RD5RW19AA	E	1	9	A
RD5RW20AA	E	2	0	A
RD5RW21AA	E	2	1	A
RD5RW22AA	E	2	2	A
RD5RW23AA	E	2	3	A
RD5RW24AA	E	2	4	A
RD5RW25AA	E	2	5	A
RD5RW26AA	E	2	6	A
RD5RW27AA	E	2	7	A
RD5RW28AA	E	2	8	A
RD5RW29AA	E	2	9	A
RD5RW30AA	E	3	0	A
RD5RW31AA	E	3	1	A
RD5RW32AA	E	3	2	A
RD5RW33AA	E	3	3	A
RD5RW34AA	E	3	4	A
RD5RW35AA	E	3	5	A
RD5RW36AA	E	3	6	A
RD5RW37AA	E	3	7	A
RD5RW38AA	E	3	8	A
RD5RW39AA	E	3	9	A
RD5RW40AA	E	4	0	A
RD5RW41AA	E	4	1	A
RD5RW42AA	E	4	2	A
RD5RW43AA	E	4	3	A
RD5RW44AA	E	4	4	A
RD5RW45AA	E	4	5	A
RD5RW46AA	E	4	6	A
RD5RW47AA	E	4	7	A
RD5RW48AA	E	4	8	A
RD5RW49AA	E	4	9	A
RD5RW50AA	E	5	0	A

Part Number	Product Code			
	①	②	③	④
RD5RW51AA	E	5	1	A
RD5RW52AA	E	5	2	A
RD5RW53AA	E	5	3	A
RD5RW54AA	E	5	4	A
RD5RW55AA	E	5	5	A
RD5RW56AA	E	5	6	A
RD5RW57AA	E	5	7	A
RD5RW58AA	E	5	8	A
RD5RW59AA	E	5	9	A
RD5RW60AA	E	6	0	A
RD5RW15BA	E	1	5	B
RD5RW16BA	E	1	6	B
RD5RW17BA	E	1	7	B
RD5RW18BA	E	1	8	B
RD5RW19BA	E	1	9	B
RD5RW20BA	E	2	0	B
RD5RW21BA	E	2	1	B
RD5RW22BA	E	2	2	B
RD5RW23BA	E	2	3	B
RD5RW24BA	E	2	4	B
RD5RW25BA	E	2	5	B
RD5RW26BA	E	2	6	B
RD5RW27BA	E	2	7	B
RD5RW28BA	E	2	8	B
RD5RW29BA	E	2	9	B
RD5RW30BA	E	3	0	B
RD5RW31BA	E	3	1	B
RD5RW32BA	E	3	2	B
RD5RW33BA	E	3	3	B
RD5RW34BA	E	3	4	B
RD5RW35BA	E	3	5	B
RD5RW36BA	E	3	6	B
RD5RW37BA	E	3	7	B
RD5RW38BA	E	3	8	B
RD5RW39BA	E	3	9	B
RD5RW40BA	E	4	0	B

Part Number	Product Code			
	①	②	③	④
RD5RW41BA	E	4	1	B
RD5RW42BA	E	4	2	B
RD5RW43BA	E	4	3	B
RD5RW44BA	E	4	4	B
RD5RW45BA	E	4	5	B
RD5RW46BA	E	4	6	B
RD5RW47BA	E	4	7	B
RD5RW48BA	E	4	8	B
RD5RW49BA	E	4	9	B
RD5RW50BA	E	5	0	B
RD5RW51BA	E	5	1	B
RD5RW52BA	E	5	2	B
RD5RW53BA	E	5	3	B
RD5RW54BA	E	5	4	B
RD5RW55BA	E	5	5	B
RD5RW56BA	E	5	6	B
RD5RW57BA	E	5	7	B
RD5RW58BA	E	5	8	B
RD5RW59BA	E	5	9	B
RD5RW60BA	E	6	0	B
RD5RW15CA	E	1	5	C
RD5RW16CA	E	1	6	C
RD5RW17CA	E	1	7	C
RD5RW18CA	E	1	8	C
RD5RW19CA	E	1	9	C
RD5RW20CA	E	2	0	C
RD5RW21CA	E	2	1	C
RD5RW22CA	E	2	2	C
RD5RW23CA	E	2	3	C
RD5RW24CA	E	2	4	C
RD5RW25CA	E	2	5	C
RD5RW26CA	E	2	6	C
RD5RW27CA	E	2	7	C
RD5RW28CA	E	2	8	C
RD5RW29CA	E	2	9	C
RD5RW30CA	E	3	0	C

Part Number	Product Code			
	①	②	③	④
RD5RW31CA	E	3	1	C
RD5RW32CA	E	3	2	C
RD5RW33CA	E	3	3	C
RD5RW34CA	E	3	4	C
RD5RW35CA	E	3	5	C
RD5RW36CA	E	3	6	C
RD5RW37CA	E	3	7	C
RD5RW38CA	E	3	8	C
RD5RW39CA	E	3	9	C
RD5RW40CA	E	4	0	C
RD5RW41CA	E	4	1	C
RD5RW42CA	E	4	2	C
RD5RW43CA	E	4	3	C
RD5RW44CA	E	4	4	C
RD5RW45CA	E	4	5	C
RD5RW46CA	E	4	6	C
RD5RW47CA	E	4	7	C
RD5RW48CA	E	4	8	C
RD5RW49CA	E	4	9	C
RD5RW50CA	E	5	0	C
RD5RW51CA	E	5	1	C
RD5RW52CA	E	5	2	C
RD5RW53CA	E	5	3	C
RD5RW54CA	E	5	4	C
RD5RW55CA	E	5	5	C
RD5RW56CA	E	5	6	C
RD5RW57CA	E	5	7	C
RD5RW58CA	E	5	8	C
RD5RW59CA	E	5	9	C
RD5RW60CA	E	6	0	C