

# FAN7000D

## Low Power Amplifier

### Features

- Low Quiescent Current
- High Power Supply Ripple Rejection
- Low Voltage Operation
- A few of External Part Required
- Built in Power Save Switch & Mute Switch

### Typical Applications

- Portable Compact Disk Player (DISCMAN)
- Portable Mini Disk Player (MD)
- Disc-Man
- MP3 Player
- CD-ROM
- Other Potable Compact Disk Media  
Fan Motor Drive

### Description

The FAN7000D is a monolithic integrated circuit and suitable dual amplifier for low power.

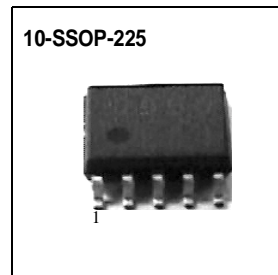

### Ordering Information

Device	Package	Operating Temp.
FAN7000D	10-SSOP-225	-20°C ~ +75°C
FAN7000DTF	10-SSOP-225	-20°C ~ +75°C

## Pin Assignments

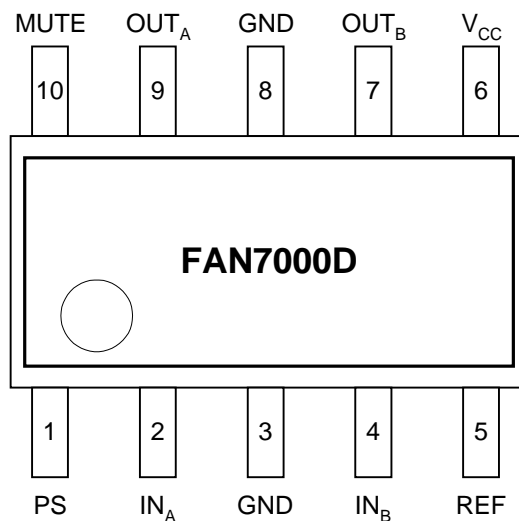

## Pin Definitions

Pin Number	Pin Name	Pin Function Description
1	PS	Power Save Switch
2	INA	Signal Input A
3	GND	Signal Ground
4	INB	Signal Input B
5	REF	Reference Voltage
6	VCC	Supply Voltage
7	OUT <sub>B</sub>	Signal Output B
8	GND	Power Ground
9	OUT <sub>A</sub>	Signal Output A
10	MUTE	Mute On Switch

## Internal Block Diagram

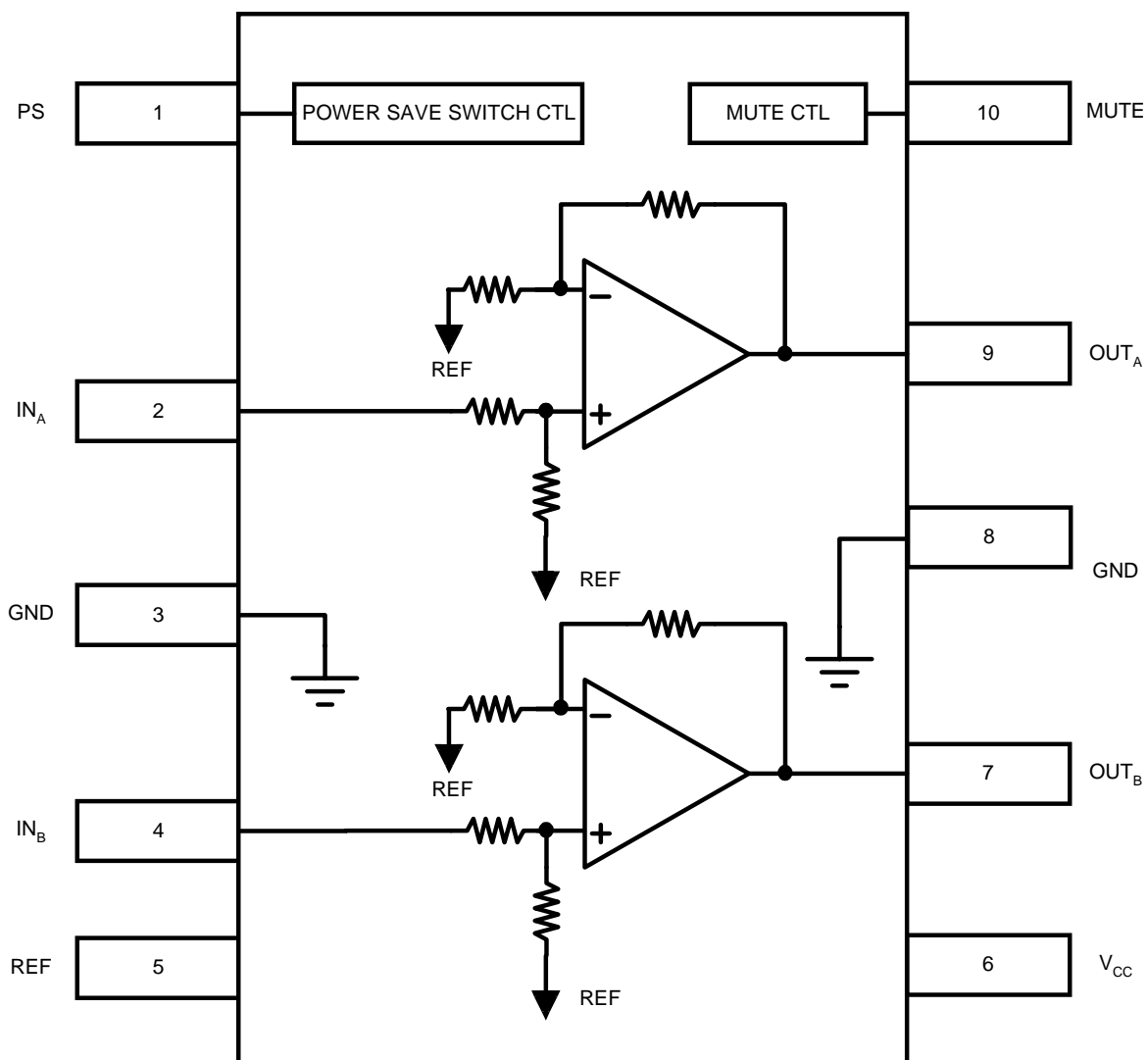

## Absolute Maximum Ratings (Ta = 25°C)

Parameter	Symbol	Value	Unit	Remark
Maximum Supply Voltage	V <sub>CC</sub>	4.5	V	Maximum Supply Voltage
Power Dissipation	P <sub>D</sub>	300	mW	Power Dissipation
Operating Temperature	T <sub>OPR</sub>	-20 ~ +75	°C	Operating Temperature
Storage Temperature	T <sub>STG</sub>	-55 ~ +125	°C	Storage Temperature
Thermal Resistance	T <sub>ja</sub>	150	°C/W	-

## Power Dissipation Curve

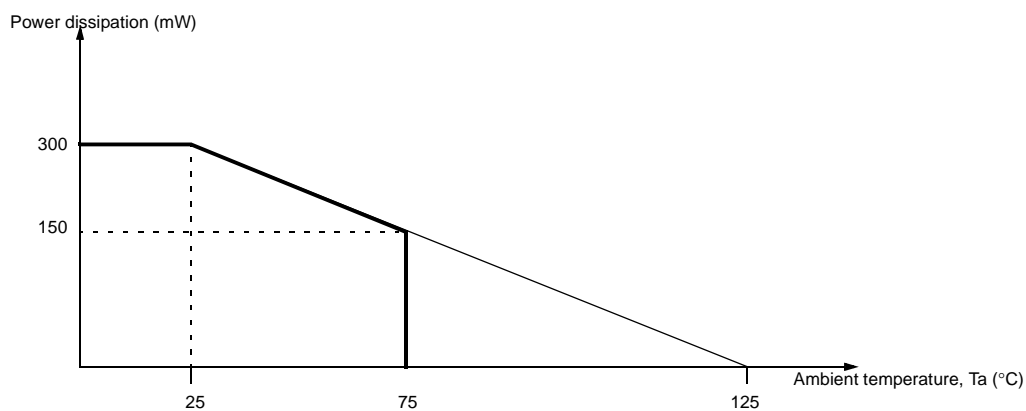

## Recommended Operating Conditions (Ta = 25°C)

Parameter	Symbol	Min.	Typ.	Max.	Unit
Operating Supply Voltage	V <sub>CC</sub>	1.8	3.0	4.0	V
Recommended Load	R <sub>L</sub>	16	-	32	Ω

**Electrical Characteristics** ( $R_L = 16\Omega$ ,  $R_g = 600\Omega$ ,  $T_a = 25^\circ\text{C}$ )

Parameter	Symbol	Conditions	Min.	Typ.	Max.	Unit
Quiescent Current 1	ICC1	$V_{CC} = 2.4\text{V}$	-	5.5	10.0	mA
Quiescent Current 2	ICC2	$V_{CC} = 4.5\text{V}$ , Mute = GND	-	1.0	2.0	mA
Quiescent Current 3	ICC3	$V_{CC} = 4.5\text{V}$ , PS = GND	-	-	1.0	$\mu\text{A}$
Close Loop Voltage Gain 1	GVC1	$V_{CC} = 2.4\text{V}$ , $f = 1\text{kHz}$ , $V_O = -10\text{dBm}$	30	32	34	dB
Close Loop Voltage Gain 2	GVC1	$V_{CC} = 1.8\text{V}$ , $f = 1\text{kHz}$ , $V_O = -20\text{dBm}$	29	32	34	dB
Channel Balance 1	$\Delta G_{V1}$	$V_{CC} = 2.4\text{V}$ , $f = 1\text{kHz}$ , $V_O = -10\text{dBm}$	-	-	1.0	dB
Channel Balance 2	$\Delta G_{V2}$	$V_{CC} = 1.8\text{V}$ , $f = 1\text{kHz}$ , $V_O = -20\text{dBm}$	-	-	1.0	dB
Total Harmonic Distortion	THD	$V_{CC} = 2.0\text{V}$ , $f = 1\text{kHz}$ , $P_O = 1\text{mW}$	-	0.5	1.5	%
Ripple Rejection Ratio	RR	$V_{CC} = 1.8\text{V}$ , $f = 100\text{Hz}$ , $R_g = 1\text{k}\Omega$ , $V_R = -20\text{dBm}$ , BPF = 100Hz	43	60	-	dB
Crosstalk	CT	$V_{CC} = 2.4\text{V}$ , $f = 100\text{Hz}$ , $R_g = 1\text{k}\Omega$ , $V_O = -10\text{dB}$	43	50	-	dB
Output Noise Voltage	VNOISE	$V_{CC} = 4.5\text{V}$ , $R_g = 1\text{k}\Omega$ , BPF = 20Hz ~ 20kHz	-	60	100	$\mu\text{Vrms}$
Output Power	POUT	$V_{CC} = 3.0\text{V}$ , $f = 1\text{kHz}$ , THD = 10%	20	40	-	mW
PS Attenuation Ratio	ATTPS	$V_{CC} = 1.8\text{V}$ , $f = 100\text{Hz}$ , PS = GND, $V_{IN} = -10\text{dB}$	-	-	-80	dB
MUTE Attenuation Ratio	ATTMU	$V_{CC} = 1.8\text{V}$ , $f = 100\text{Hz}$ , MUTE = GND, $V_{IN} = -10\text{dB}$	-	-	-80	dB
PS ON Input Current	IPSON	$V_{CC} = 1.5\text{V}$ , $V_{REF} \geq 0.85\text{V}$	-	0.2	1.0	$\mu\text{A}$
MUTE OFF Input Current	IMOFF	$V_{CC} = 1.5\text{V}$ , $V_{REF} \geq 0.85\text{V}$	-	0.2	1.0	$\mu\text{A}$
PS ON High Level	VHPS	$V_{CC} = 1.5\text{V}$ , $V_{REF} \geq 0.85\text{V}$	0.5	0.65	-	V
MUTE OFF High Level	VHMU	$V_{CC} = 1.5\text{V}$ , $V_{REF} \geq 0.85\text{V}$	0.5	0.65	-	V

## Application Information

### 1. PS Block

This block diagram describes the power save switch circuits.

The drive block is controlled by PS pin, which can be derived from micro controller.

It controls bias of the internal circuits of FAN7000D, so that it makes FAN7000D operate when input voltage level reaches high level.

### 2. Mute Block

The block diagram describes the mute on switch circuits.

The drive block is controlled by MUTE pin, which can be derived from micro controller.

When the pin of mute turns on, it makes reference voltage of internal circuits approximately 0V, so that it keeps the device of FAN7000D off.

### 3. AMP Block

This block diagram describes the AMP block with resistances, which control gain of FAN7000D.

The gain of FAN7000D is  $\frac{V_{OUT}}{V_{IN}} \cong 40 \cong 32[\text{dB}]$

Output voltage of FAN7000D can be 40 times as much as input voltage, so it eliminates the number of external circuits and offers headphone input.

### 4. Popping Noise Reduction

If PS pin (Pin1 , Power save switch) connect the micro controller, the micro controller must follow the same sequence 1 in order to reduce popping noise on mute mode.

PS on → Mute on → PS off → Mute operation → PS on → Mute off → Normal operation (Sequence 1) If PS connect VCC, the micro controller follow the sequence 2.

Mute on → Mute Operation → Mute off → Normal operation (Sequence 2)

## Test Circuits

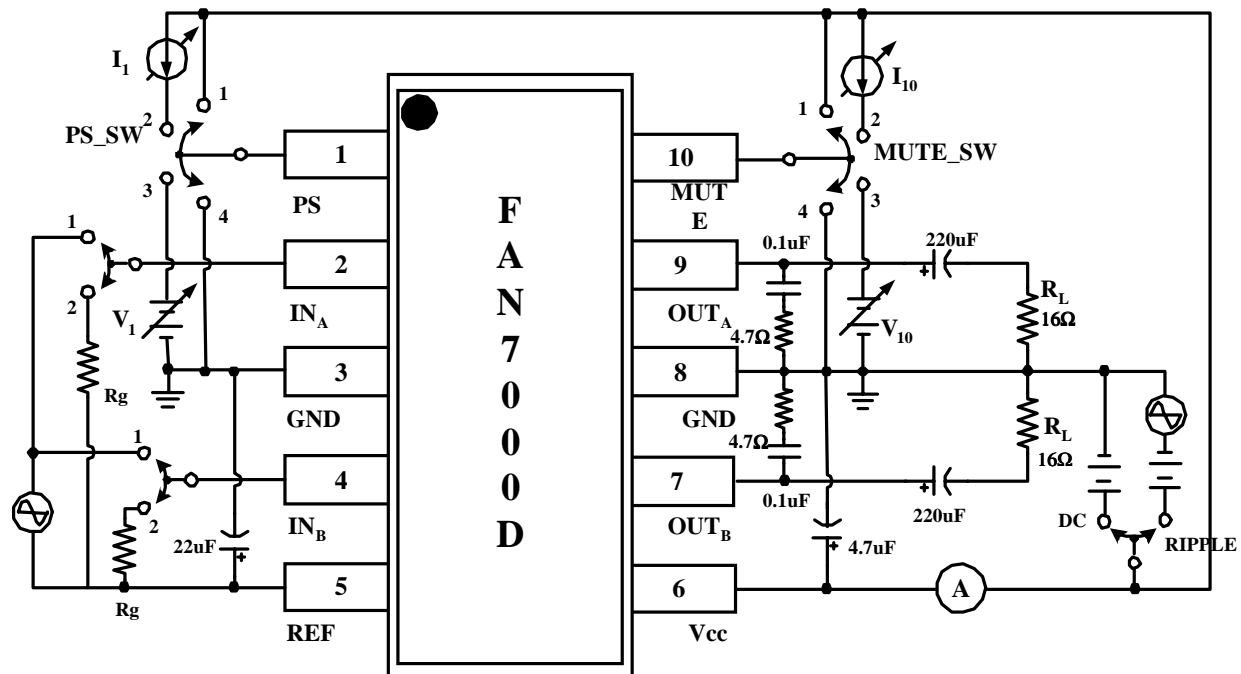

## Typical Application Circuits

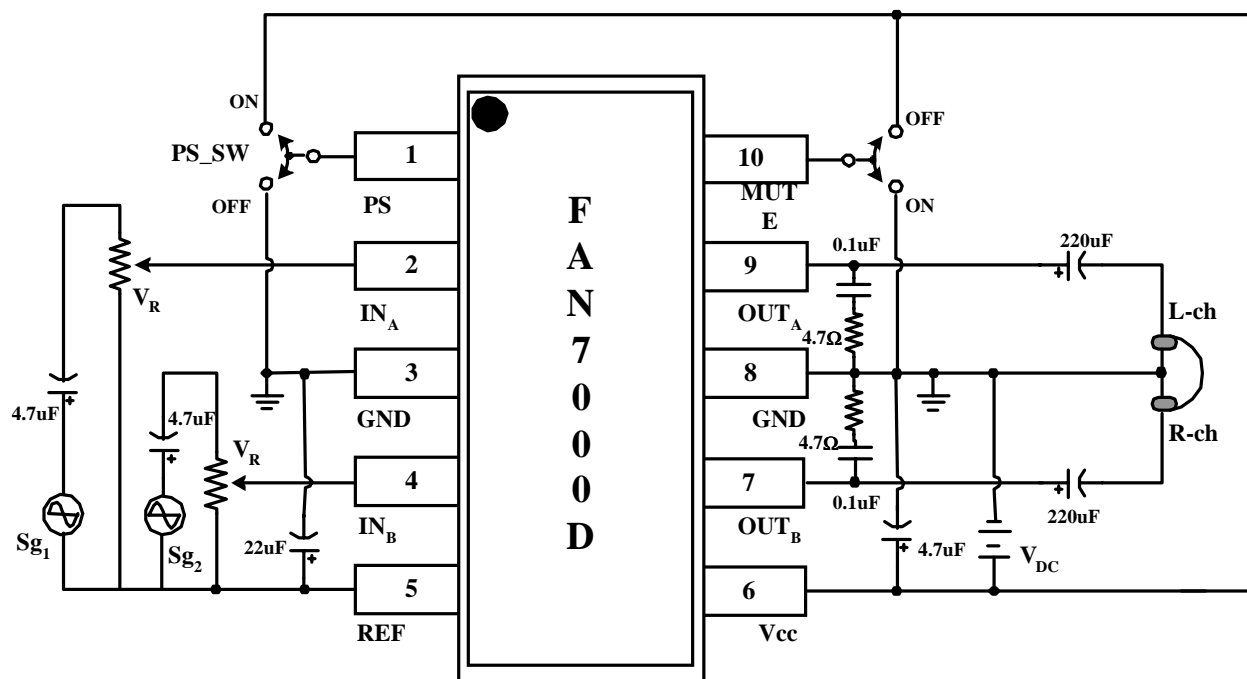





**DISCLAIMER**

FAIRCHILD SEMICONDUCTOR RESERVES THE RIGHT TO MAKE CHANGES WITHOUT FURTHER NOTICE TO ANY PRODUCTS HEREIN TO IMPROVE RELIABILITY, FUNCTION OR DESIGN. FAIRCHILD DOES NOT ASSUME ANY LIABILITY ARISING OUT OF THE APPLICATION OR USE OF ANY PRODUCT OR CIRCUIT DESCRIBED HEREIN; NEITHER DOES IT CONVEY ANY LICENSE UNDER ITS PATENT RIGHTS, NOR THE RIGHTS OF OTHERS.

**LIFE SUPPORT POLICY**

FAIRCHILD'S PRODUCTS ARE NOT AUTHORIZED FOR USE AS CRITICAL COMPONENTS IN LIFE SUPPORT DEVICES OR SYSTEMS WITHOUT THE EXPRESS WRITTEN APPROVAL OF THE PRESIDENT OF FAIRCHILD SEMICONDUCTOR CORPORATION. As used herein:

1. Life support devices or systems are devices or systems which, (a) are intended for surgical implant into the body, or (b) support or sustain life, and (c) whose failure to perform when properly used in accordance with instructions for use provided in the labeling, can be reasonably expected to result in a significant injury of the user.
2. A critical component in any component of a life support device or system whose failure to perform can be reasonably expected to cause the failure of the life support device or system, or to affect its safety or effectiveness.