

LM7372

High Speed, High Output Current, Dual Operational Amplifier

General Description

The LM7372 is a high speed dual voltage feedback amplifier that has the slewing characteristic of current feedback amplifiers; yet it can be used in all traditional voltage feedback amplifier configurations.

The LM7372 is stable for gains as low as +2 or -1. It provides a very high slew rate at 3000V/ μ s and a wide gain bandwidth product of 120MHz, while consuming only 6.5mA/per amplifier of supply current. It is ideal for video and high speed signal processing applications such as xDSL and pulse amplifiers. With 150mA output current, the LM7372 can be used for video distribution, as a transformer driver or as a laser diode driver.

Operation on ± 15 V power supplies allows for large signal swings and provides greater dynamic range and signal-to-noise ratio. The LM7372 offers high SFDR and low THD, ideal for ADC/DAC systems. In addition, the LM7372 is specified for ± 5 V operation for portable applications.

The LM7372 is built on National's Advance VIP™ III (Vertically integrated PNP) complementary bipolar process.

Features

- -80dBc highest harmonic distortion @1MHz, 2V_{PP}
- Very high slew rate: 3000V/ μ s
- Wide gain bandwidth product: 120MHz
- -3dB frequency @ A_v = +2: 200MHz
- Low supply current: 13mA (both amplifiers)
- High open loop gain: 85dB
- High output current: 150mA
- Differential gain and phase: 0.01%, 0.02°

Applications

- HDSL and ADSL Drivers
- Multimedia broadcast systems
- Professional video cameras
- CATV/Fiber optics signal processing
- Pulse amplifiers and peak detectors
- HDTV amplifiers

Typical Application

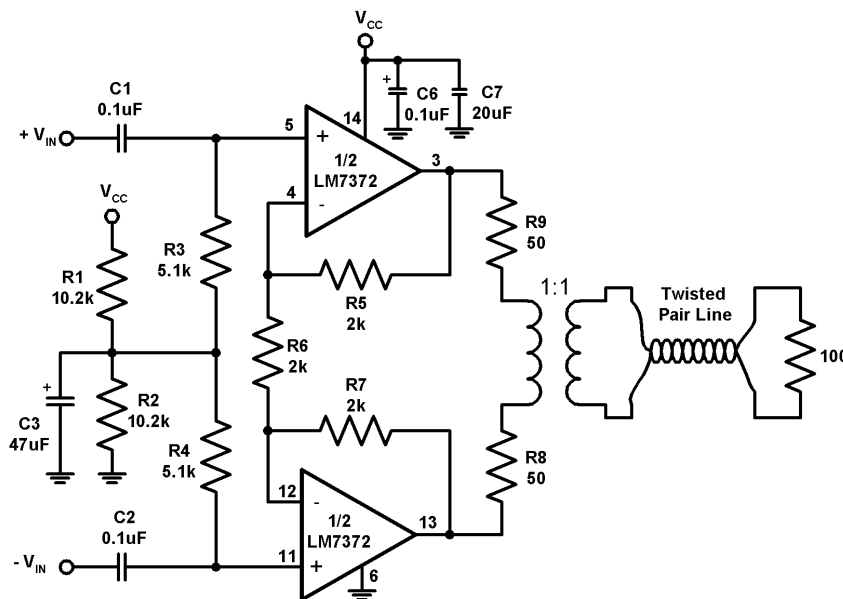

20004903

FIGURE 1. Single Supply Application (SOIC-16)

Connection Diagrams

16-Pin SOIC

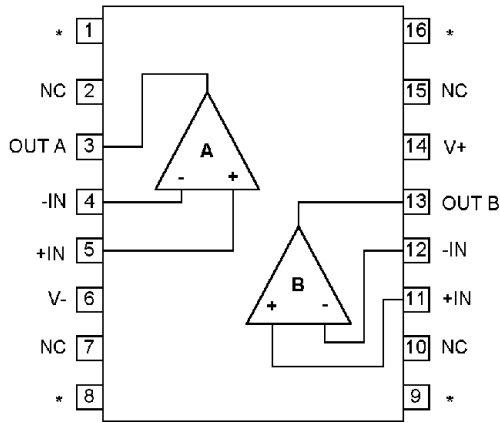

20004902

Top View

8-Contact LLP

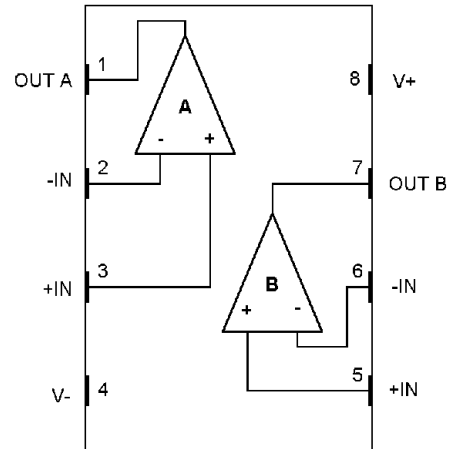

20004901

Top View

* Heatsink Pins. See note 4

8-Pin PSOP

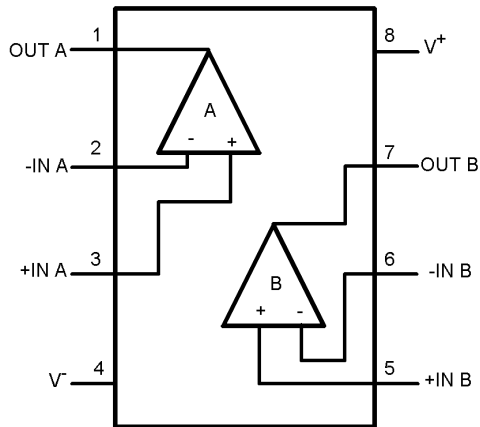

20004929

Top View

For PSOP SOIC-8 the exposed pad should be tied either to V^- or left electrically floating. (die attach material is conductive and is internally tied to V^-)

Ordering Information

Symbol	Temperature Range	Package Marking	Transport Media	NSC Drawing
	-40°C to +85°C			
16-Pin SOIC	LM7372IMA	LM7372IMA	Rails	M16A
	LM7372IMAX	LM7372IMA	2.5k Units Tape and Reel	
8-Pin LLP	LM7372ILD	L7372	1k Units Tape and Reel	LDC08A
	LM7372ILD _X	L7372	4.5k Units Tape and Reel	
8-Pin PSOP	LM7372MR	LM7372MR	Rails	MRA08A
	LM7372MR _X	LM7372MR	2.5k Units Tape and Reel	

Absolute Maximum Ratings (Notes 1,

3)

If Military/Aerospace specified devices are required, please contact the National Semiconductor Sales Office/Distributors for availability and specifications.

ESD Tolerance	
Human Body Model	1.5kV (Note 2)
Machine Model	200V (Note 2)
Supply Voltage ($V^+ - V^-$)	36V
Differential Input Voltage ($V_S = \pm 15V$)	$\pm 10V$
Output Short Circuit to Ground (Note 3)	Continuous
Storage Temp. Range	$-65^\circ C$ to $150^\circ C$
Soldering Information	
Infrared or Convection Reflow (20 sec.)	$235^\circ C$
Wave Soldering Lead Temperature (10 sec.)	$260^\circ C$

Input Voltage	V^- to V^+
Maximum Junction Temperature (Note 4)	$150^\circ C$

Operating Ratings (Note 1)

Supply Voltage	$9V \leq V_S \leq 36V$
Junction Temperature Range (T_J)	$-40^\circ C \leq T_J \leq 85^\circ C$
LM7372	
Thermal Resistance (θ_{JA})	
16-Pin SOIC See (Note 4)	$106^\circ C/W$
	$70^\circ C/W$
LLP-8 Package (See Application Section)	$40^\circ C/W$
8-Pin PSOP (See Application Section)	$59^\circ C/W$

$\pm 15V$ DC Electrical Characteristics

Unless otherwise specified, all limits guaranteed for $T_J = 25^\circ C$, $V_{CM} = 0V$ and $R_L = 1k\Omega$. **Boldface** apply at the temperature extremes.

Symbol	Parameter	Conditions	Min (Note 6)	Typ (Note 5)	Max (Note 6)	Units
V_{OS}	Input Offset Voltage			2.0	8.0 10.0	mV
TC V_{OS}	Input Offset Voltage Average Drift			12		$\mu V/^\circ C$
I_B	Input Bias Current			2.7	10 12	μA
I_{OS}	Input Offset Current			0.1	4.0 6.0	μA
R_{IN}	Input Resistance	Common Mode		40		$M\Omega$
		Differential Mode		3.3		$M\Omega$
R_O	Open Loop Output Resistance			15		Ω
CMRR	Common Mode Rejection Ratio	$V_{CM} = \pm 10V$	75 70	93		dB
PSRR	Power Supply Rejection Ratio	$V_S = \pm 15V$ to $\pm 5V$	75 70	90		dB
V_{CM}	Input Common-Mode Voltage Range	CMRR > 60dB		± 13		V
A_V	Large Signal Voltage Gain (Note 7)	$R_L = 1k\Omega$	75 70	85		dB
		$R_L = 100\Omega$	70 66	81		dB
V_O	Output Swing	$R_L = 1k\Omega$	13 12.7	13.4		V
			-13 -12.7	-13.3		V
		$I_{OUT} = -150mA$	11.8 11.4	12.4		V
		$I_{OUT} = 150mA$	-11.2 -10.8	-11.9		V
I_{SC}	Output Short Circuit Current	Sourcing		260		mA
		Sinking		250		mA

±15V DC Electrical Characteristics (Continued)

Unless otherwise specified, all limits guaranteed for $T_J = 25^\circ\text{C}$, $V_{CM} = 0\text{V}$ and $R_L = 1\text{k}\Omega$. **Boldface** apply at the temperature extremes.

Symbol	Parameter	Conditions	Min (Note 6)	Typ (Note 5)	Max (Note 6)	Units
I_S	Supply Current (both Amps)			13	17 19	mA

±15V AC Electrical Characteristics

Unless otherwise specified, all limits guaranteed for $T_J = 25^\circ\text{C}$, $V_{CM} = 0\text{V}$ and $R_L = 1\text{k}\Omega$. **Boldface** apply at the temperature extremes.

Symbol	Parameter	Conditions	Min (Note 6)	Typ (Note 5)	Max (Note 6)	Units
SR	Slew Rate (Note 8)	$A_V = +2$, $V_{IN} = 13V_{P-P}$		3000		V/ μs
		$A_V = +2$, $V_{IN} = 10V_{P-P}$		2000		
	Unity Bandwidth Product			120		MHz
	-3dB Frequency	$A_V = +2$		220		MHz
ϕ_m	Phase Margin	$A_{VOL} = 6\text{dB}$		70		deg
t_S	Settling Time (0.1%)	$A_V = -1$, $A_O = \pm 5\text{V}$, $R_L = 500\Omega$		50		ns
t_P	Propagation Delay	$A_V = -2$, $V_{IN} = \pm 5\text{V}$, $R_L = 500\Omega$		6.0		ns
A_D	Differential Gain (Note 9)			0.01		%
ϕ_D	Differential Phase (Note 9)			0.02		deg
hd2	Second Harmonic Distortion $F_{IN} = 1\text{MHz}$, $A_V = +2$	$V_{OUT} = 2V_{P-P}$, $R_L = 100\Omega$		-80		dBc
		$V_{OUT} = 16.8V_{P-P}$, $R_L = 100\Omega$		-73		
hd3	Third Harmonic Distortion $F_{IN} = 1\text{MHz}$, $A_V = +2$	$V_{OUT} = 2V_{P-P}$, $R_L = 100\Omega$		-91		dBc
		$V_{OUT} = 16.8V_{P-P}$, $R_L = 100\Omega$		-67		
IMD	Intermodulation Distortion	$F_{in 1} = 75\text{kHz}$, $F_{in 2} = 85\text{kHz}$, $V_{OUT} = 16.8V_{P-P}$, $R_L = 100\Omega$		-87		dBc
e_n	Input-Referred Voltage Noise	$f = 10\text{kHz}$		14		$\text{nV}/\sqrt{\text{Hz}}$
i_n	Input-Referred Current Noise	$f = 10\text{kHz}$		1.5		$\text{pA}/\sqrt{\text{Hz}}$

±5V DC Electrical Characteristics

Unless otherwise specified, all limits guaranteed for $T_J = 25^\circ\text{C}$, $V_{CM} = 0\text{V}$ and $R_L = 1\text{k}\Omega$. **Boldface** apply at the temperature extremes.

Symbol	Parameter	Conditions	Min (Note 6)	Typ (Note 5)	Max (Note 6)	Units
V_{OS}	Input Offset Voltage			2.2	8.0 10.0	mV
TC V_{OS}	Input Offset Voltage Average Drift			12		$\mu\text{V}/^\circ\text{C}$
I_B	Input Bias Current			3.3	10 12	μA
I_{OS}	Input Offset Current			0.1	4 6	μA
R_{IN}	Input Resistance	Common Mode		40		$\text{M}\Omega$
		Differential Mode		3.3		$\text{M}\Omega$
R_O	Open Loop Output Resistance			15		Ω
CMRR	Common Mode Rejection Ratio	$V_{CM} = \pm 2.5\text{V}$	70 65	90		dB

±5V DC Electrical Characteristics (Continued)

Unless otherwise specified, all limits guaranteed for $T_J = 25^\circ\text{C}$, $V_{CM} = 0\text{V}$ and $R_L = 1\text{k}\Omega$. **Boldface** apply at the temperature extremes.

Symbol	Parameter	Conditions	Min (Note 6)	Typ (Note 5)	Max (Note 6)	Units
PSRR	Power Supply Rejection Ratio	$V_S = \pm 15\text{V}$ to $\pm 5\text{V}$	75 70	90		dB
V_{CM}	Input Common-Mode Voltage Range	CMRR > 60dB		± 3		V
A_V	Large Signal Voltage Gain (Note 7)	$R_L = 1\text{k}\Omega$	70 65	78		dB
		$R_L = 100\Omega$	64 60	72		dB
V_O	Output Swing	$R_L = 1\text{k}\Omega$	3.2 3.0	3.4		V
			-3.2 -3.0	-3.4		V
		$I_{OUT} = -80\text{mA}$	2.5 2.2	2.8		V
		$I_{OUT} = 80\text{mA}$	-2.5 -2.2	-2.7		V
I_{SC}	Output Short Circuit Current	Sourcing		150		mA
		Sinking		150		mA
I_S	Supply Current (both Amps)			12.4	16 18	mA

±5V AC Electrical Characteristics

Unless otherwise specified, all limits guaranteed for $T_J = 25^\circ\text{C}$, $V_{CM} = 0\text{V}$ and $R_L = 1\text{k}\Omega$. **Boldface** apply at the temperature extremes.

Symbol	Parameter	Conditions	Min (Note 6)	Typ (Note 5)	Max (Note 6)	Units
SR	Slew Rate (Note 8)	$A_V = +2$, $V_{IN} = 3V_{P-P}$		700		V/ μs
	Unity Bandwidth Product			100		MHz
	-3dB Frequency	$A_V = +2$		125		MHz
ϕ_m	Phase Margin			70		deg
t_S	Settling Time (0.1%)	$A_V = -1$, $V_O = \pm 1\text{V}$, $R_L = 500\Omega$		70		ns
t_P	Propagation Delay	$A_V = +2$, $V_{IN} = \pm 1\text{V}$, $R_L = 500\Omega$		7		ns
A_D	Differential Gain (Note 9)			0.02		%
ϕ_D	Differential Phase (Note 9)			0.03		deg
hd2	Second Harmonic Distortion $F_{IN} = 1\text{MHz}$, $A_V = +2$	$V_{OUT} = 2V_{P-P}$, $R_L = 100\Omega$		-84		dBc
hd3	Third Harmonic Distortion $F_{IN} = 1\text{MHz}$, $A_V = +2$	$V_{OUT} = 2V_{P-P}$, $R_L = 100\Omega$		-94		dBc
e_n	Input-Referred Voltage Noise	$f = 10\text{kHz}$		14		nV/ $\sqrt{\text{Hz}}$
i_n	Input-Referred Current Noise	$f = 10\text{kHz}$		1.8		pA/ $\sqrt{\text{Hz}}$

Note 1: Absolute Maximum Ratings indicate limits beyond which damage to the device may occur. Operating Ratings indicate conditions for which the device is intended to be functional, but specific performance is not guaranteed. For guaranteed specifications and the test conditions, see the Electrical Characteristics.

Note 2: For testing purposes, ESD was applied using human body model, 1.5k Ω in series with 100pF. Machine model, 0 Ω in series with 200pF.

Note 3: Applies to both single-supply and split-supply operation. Continuous short circuit operation at elevated ambient temperature can result in exceeding the maximum allowed junction temperature of 150°C.

±5V AC Electrical Characteristics (Continued)

Note 4: The maximum power dissipation is a function of $T_{(JMAX)}$, θ_{JA} , and T_A . The maximum allowable power dissipation at any ambient temperature is $P_D = (T_{(JMAX)} - T_A)/\theta_{JA}$. All numbers apply for packages soldered directly into a PC board. The value for θ_{JA} is 106°C/W for the SOIC 16 package. With a total area of 4sq. in. of 1oz CU connected to pins 1,6,8,9 & 16, θ_{JA} for the SOIC 16 is decreased to 70°C/W .

Note 5: Typical values represent the most likely parametric norm.

Note 6: All limits are guaranteed by testing or statistical analysis.

Note 7: Large signal voltage gain is the total output swing divided by the input signal required to produce that swing. For $V_S = \pm 15\text{V}$, $V_{OUT} = \pm 10\text{V}$. For $V_S = \pm 5\text{V}$, $V_{OUT} = \pm 2\text{V}$.

Note 8: Slew Rate is the average of the rising and falling slew rates.

Note 9: Differential gain and phase are measured with $A_V = +2$, $V_{IN} = 1\text{V}_{PP}$ at 3.58MHz and output is 150Ω terminated.

Typical Performance Characteristics

Harmonic Distortion vs. Frequency

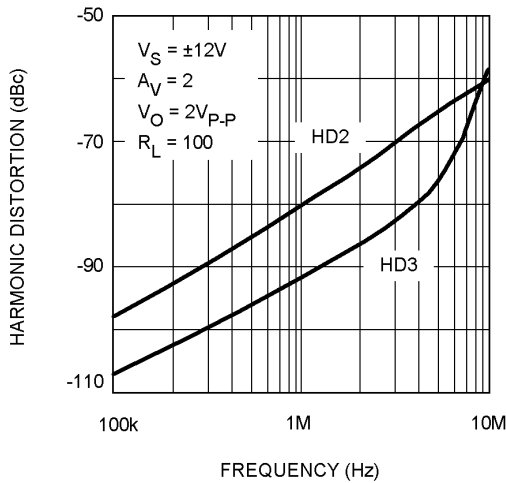

Harmonic Distortion vs. Frequency

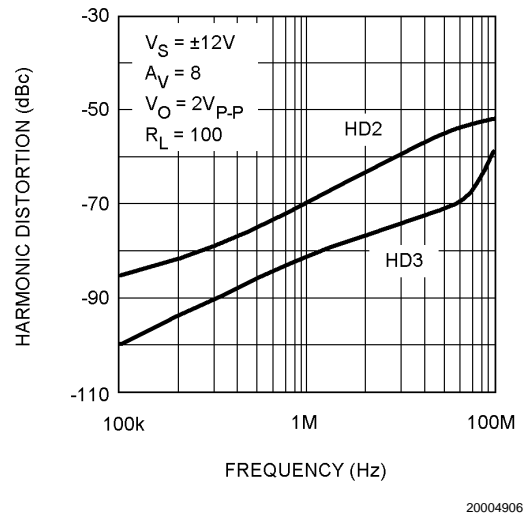

Harmonic Distortion vs. Frequency

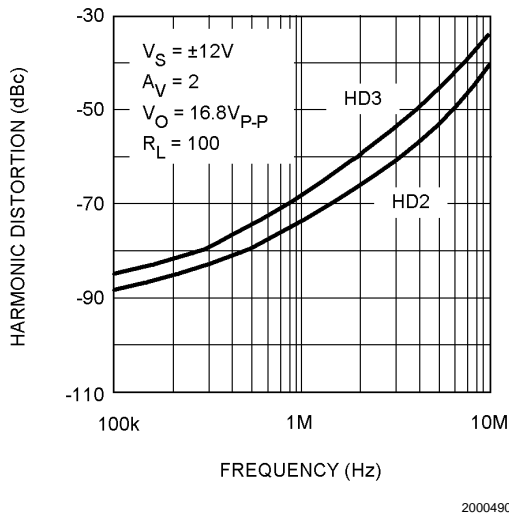

Harmonic Distortion vs. Frequency

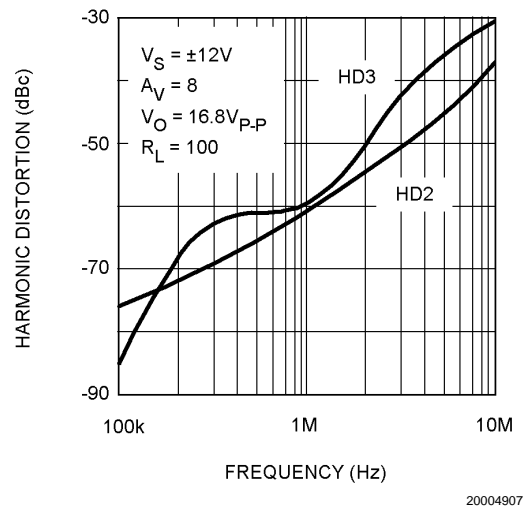

Typical Performance Characteristics (Continued)

Harmonic Distortion vs. Output Level

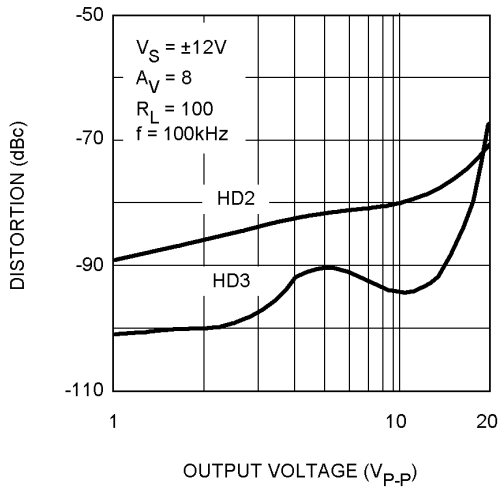

20004908

Harmonic Distortion vs. Output Level



20004909

Harmonic Distortion vs. Output Level

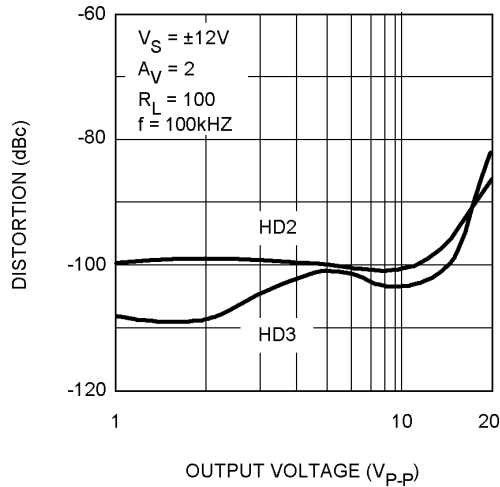

20004910

Harmonic Distortion vs. Output Level

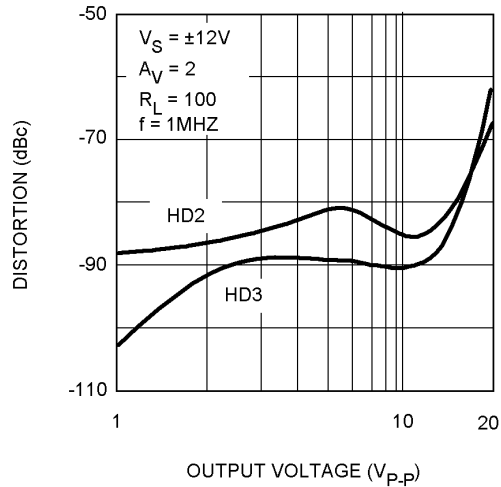

20004911

Harmonic Distortion vs. Load Resistance

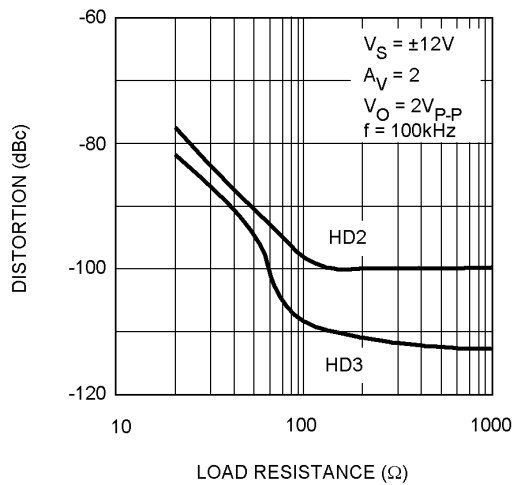

20004912

Harmonic Distortion vs. Load Resistance

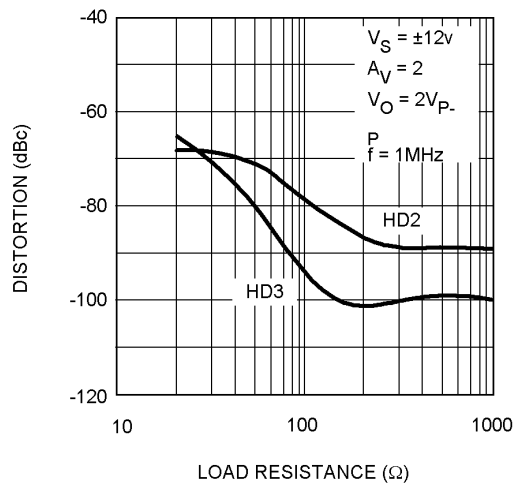

20004913

Typical Performance Characteristics (Continued)

Harmonic Distortion vs. Load Resistance

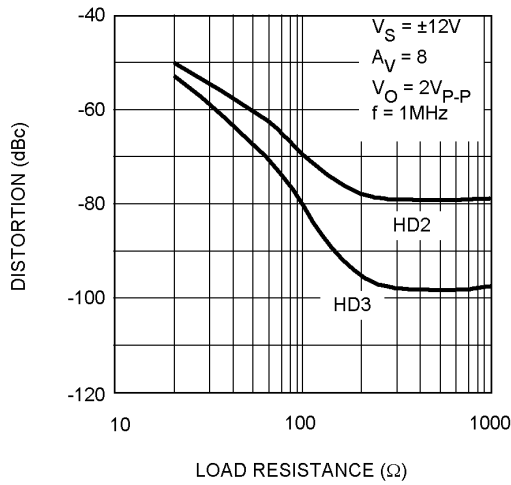

20004914

Harmonic Distortion vs. Load Resistance

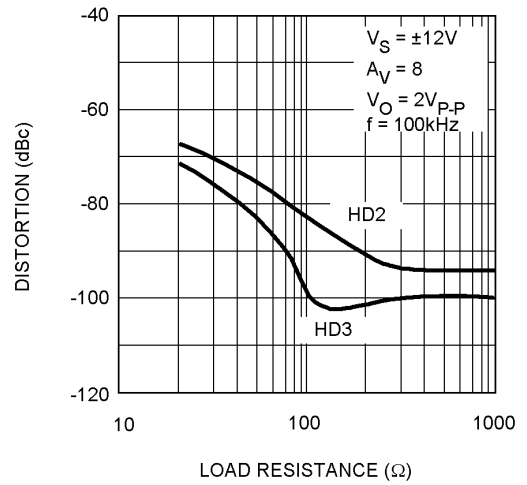

20004915

Frequency Response

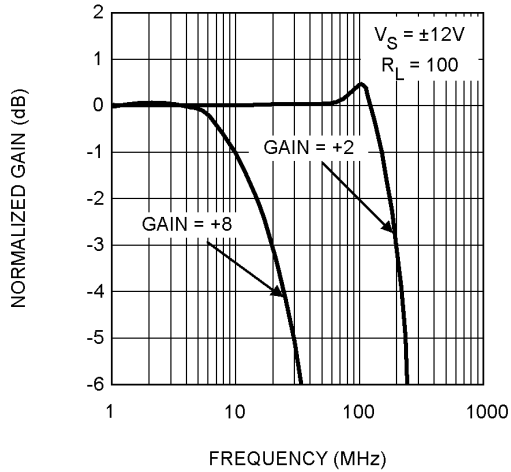

20004916

Frequency Response

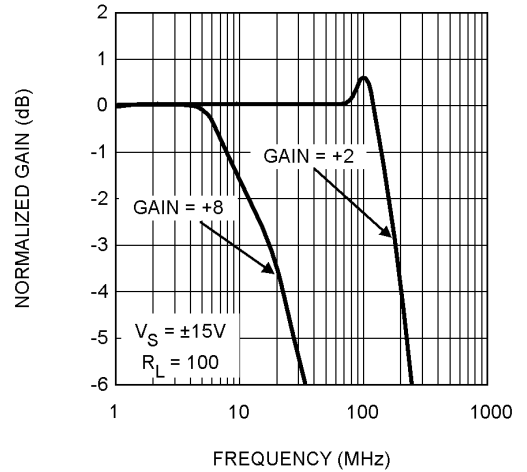

20004917

Frequency Response

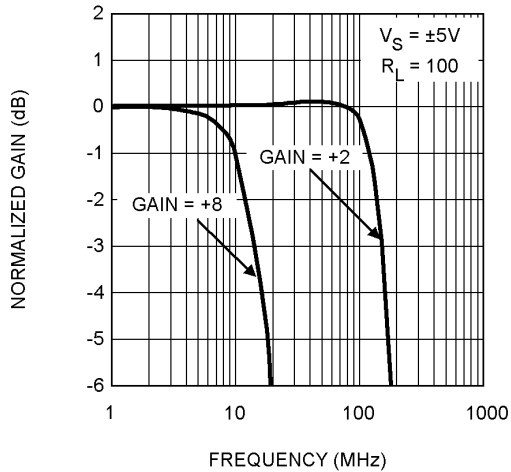

20004918

Small Signal Pulse Response

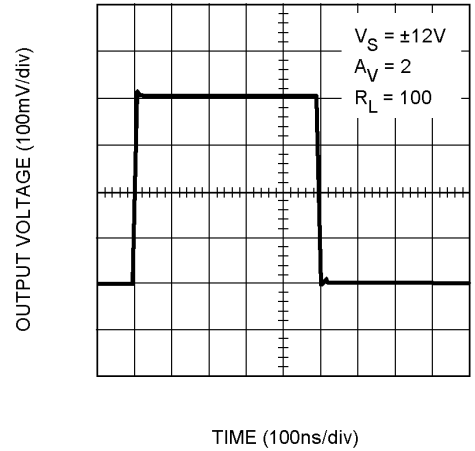

20004920

Typical Performance Characteristics (Continued)

Large Signal Pulse Response

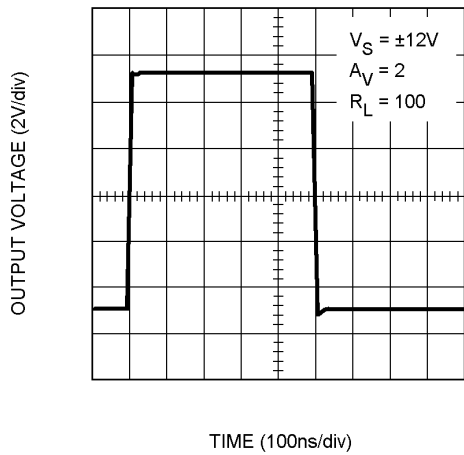

20004921

Thermal Performance of 8ld-LLP

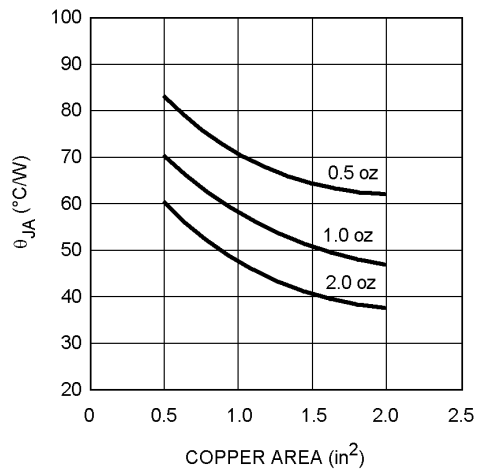

20004922

Harmonic Distortion vs. Frequency

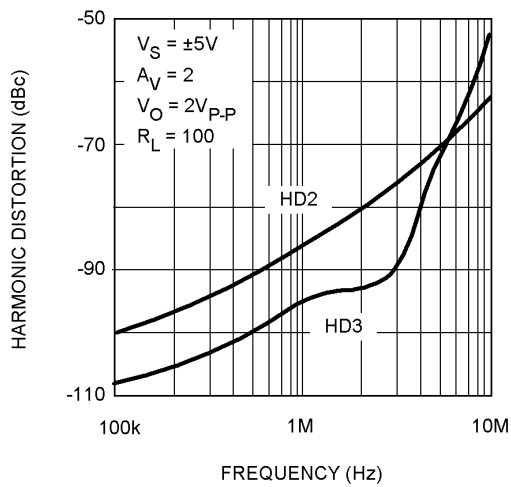

20004927

Input Bias Current (μA) vs. Temperature

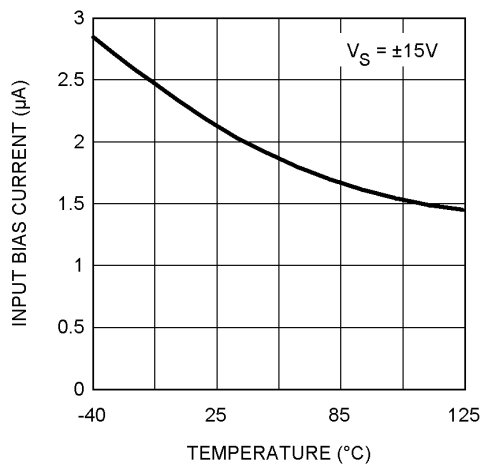

20004923

Output Voltage vs. Output Current

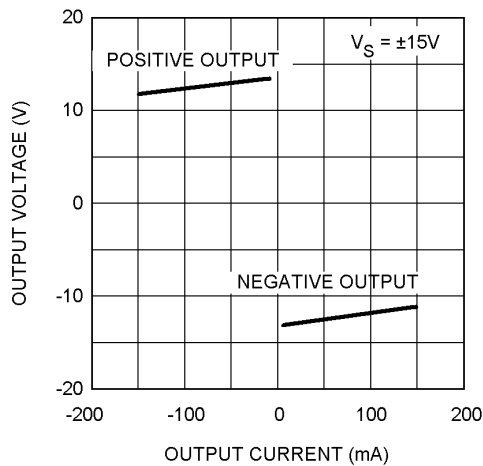

20004924

Simplified Schematic Diagram

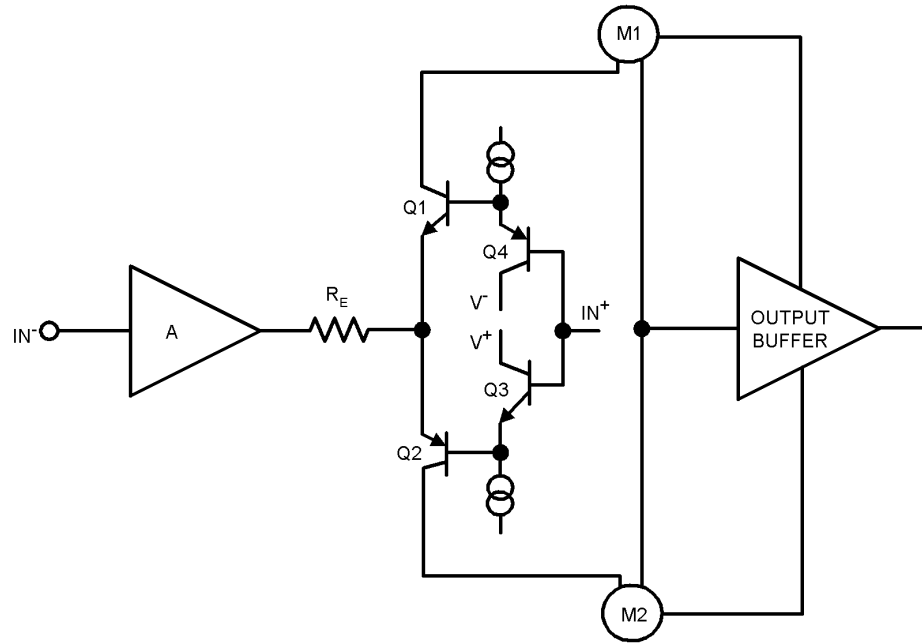

20004928

Application Notes

The LM7372 is a high speed dual operational amplifier with a very high slew rate and very low distortion, yet like many other op amps, it is used in conventional voltage feedback amplifier applications. Also, again like many op amps, it has a class AB output stage in order to be able to deliver high currents to low impedance loads, yet draw very little quiescent supply current. For most op-amps in typical applications, this topology means that internal power dissipation is rarely an issue, even with the trend to smaller surface mount packages. However, the LM7372 has been designed for applications where significant levels of power dissipation will be encountered, and an effective means of removing the internal heat generated by this power dissipation is needed to maintain the semiconductor junction temperature at acceptable levels, particularly in environments with elevated ambient temperatures.

Several factors contribute to power dissipation and consequently higher semiconductor junction temperatures, and these factors need to be well understood if the LM7372 is to perform to the desired specifications in a given application. Since different applications will have different dissipation levels and different compromises can be made between the ways these factors will contribute to the total junction temperature, this section will examine the typical application shown on the front page of this data sheet as an example, and offer suggestions for solutions where excessive junction temperatures are encountered.

There are two major contributors to the internal power dissipation; the product of the supply voltage and the LM7372 quiescent current when no signal is being delivered to the external load, and the additional power dissipated while delivering power to the external load. The first of these components is easy to calculate simply by inspection of the data sheet. The LM7372 quiescent supply current is given as 6.5mA per amplifier, so with a 24Volt supply the power dissipation is

$$\begin{aligned} PQ &= V_S \times 2I_q \quad (V_S = V_{CC} + V_{EE}) \\ &= 24 \times (6.5 \times 10^{-3}) \\ &= 312\text{mW} \end{aligned}$$

This is already a high level of internal power dissipation, and in a small surface mount package with a thermal resistance ($\theta_{JA} = 140^\circ\text{C}/\text{Watt}$ (a not unreasonable value for an SO-8 package) would result in a junction temperature $140^\circ\text{C}/\text{W} \times 0.312\text{W} = 43.7^\circ\text{C}$ above the ambient temperature. A similar calculation using the worst case maximum current limit at an 85°C ambient will yield a power dissipation of 456mW with a junction temperature of 149°C , perilously close to the maximum permitted junction temperature of 150°C !

The second contributor to high junction temperature is the additional power dissipated internally when power is being delivered to the external load. This cause of temperature rise can be less amenable to calculation, even when the actual operating conditions are known.

For a Class B output stage, one transistor of the output pair will conduct the load current as the output voltage swings positive, with the other transistor drawing no current, and hence dissipating no power. During the other half of the signal swing this situation is reversed, with the lower transistor sinking the load current and the upper transistor is cut off. The current in each transistor will be a half wave rectified version of the total load current. Ideally neither transistor will dissipate power when there is no signal swing, but will dissipate increasing power as the output current increases. However, as the signal voltage across the load increases with load current, the voltage across the output transistor (which is the difference voltage between the supply voltage and the instantaneous voltage across the load) will decrease and a point will be reached where the dissipation in the transistor will begin to decrease again. If the signal is driven into a square wave, ideally the transistor dissipation will fall all the way back to zero.

Application Notes (Continued)

For each amplifier then, with an effective load each of R_L and a sine wave source, integration over the half cycle with a supply voltage V_S and a load voltage V_L yields the average power dissipation

$$P_D = V_S V_L / \pi R_L - V_L^2 / 2R_L \dots \dots (1)$$

Where V_S is the supply voltage and V_L is the peak signal swing across the load R_L .

For the package, the power dissipation will be doubled since there are two amplifiers in the package, each contributing half the swing across the load.

The circuit in *Figure 1* is using the LM7372 as the upstream driver in an ADSL application with Discrete MultiTone modulation. With DMT the upstream signal is spread into 32 adjacent channels each 4kHz wide. For transmission over POTS, the regular telephone service, this upstream signal from the CPE (Customer Premise Equipment) occupies a frequency band from around 20kHz up to a maximum frequency of 135kHz. At first sight, these relatively low transmission frequencies certainly do not seem to require the use of very high speed amplifiers with GBW products in the range of hundreds of megahertz. However, the close spacing of multiple channels places stringent requirements on the linearity of the amplifier, since non-linearities in the presence of multiple tones will cause harmonic products to be generated that can easily interfere with the higher frequency downstream signals also present on the line. The need to deliver 3rd Harmonic distortion terms lower than -75dBc is the reason for the LM7372 quiescent current levels. Each amplifier is running over 3mA in the output stage alone in order to minimize crossover distortion.

xDSL signal levels are adjusted to provide a given power level on the line, and in the case of ADSL this is an average power of 13dBm. For a line with a characteristic impedance of 100Ω this is only 20mW. Because the transformer shown in *Figure 1* is part of a transceiver circuit, two back-termination resistors are connected in series with each amplifier output. Therefore the equivalent R_L for each amplifier is also 100Ω , and each amplifier is required to deliver 20mW to this load.

$$\text{Since } V_L^2 / 2R_L = 20\text{mW then } V_L = 2V(\text{peak}).$$

Using Equation (1) with this value for signal swing and a 24V supply, the internal power dissipation per amplifier is 132.8mW. Adding the quiescent power dissipation to the amplifier dissipation gives the total package internal power dissipation as

$$P_{D(\text{Total})} = 312\text{mW} + (2 \times 132.8\text{mW}) = 578\text{mW}$$

This result is actually quite pessimistic because it assumes that the dissipation as a result of load current is simply added to the dissipation as a result of quiescent current. This is not correct since the AB bias current in the output stage is diverted to load current as the signal swing amplitude increases from zero. In fact with load currents in excess of 3.3mA, all the bias current is flowing in the load, consequently reducing the quiescent component of power dissipation. Also, it assumes a sine wave signal waveform when the actual waveform is composed of many tones of different phases and amplitudes which may demonstrate lower average power dissipation levels.

The average current for a load power of 20mW is 14.1mA. Neglecting the AB bias current this appears as a full-wave rectified current waveform in the supply current with a peak value of 19.9mA. The peak to average ratio for a waveform of this shape is 1.57, so the total average load current is

12.7mA. Adding this to the quiescent current, and subtracting the power dissipated in the load gives the same package power dissipation level calculated above. Nevertheless, when the supply current peak swing is measured, it is found to be significantly lower because the AB bias current is contributing to the load current. The supply current has a peak swing of only 14mA (compared to 19.9mA) superimposed on the quiescent current, with a total average value of only 21mA. Therefore the total package power dissipation in this application is

$$\begin{aligned} P_{D(\text{Total})} &= (V_S \times \text{Iavg}) - \text{Power in Load} \\ &= (24 \times 21)\text{mW} - 40\text{mW} \\ &= 464\text{mW} \end{aligned}$$

This level of power dissipation would not take the junction temperature in the SO-8 package over the absolute maximum rating at elevated ambient temperatures (barely), but there is no margin to allow for component tolerances or signal variances.

To develop 20mW in a 100Ω requires each amplifier to deliver a peak voltage of only 2V, or $4V_{(p-p)}$. This level of signal swing does not require a high supply voltage but the application uses a 24V supply. This is because the modulation technique uses a large number of tones to transmit the data. While the average power level is held to 20mW, at any time the phase and amplitude of individual tones will be such as to generate a combined signal with a higher peak value than 2V. For DMT this crest factor is taken to be around 5.33 so each amplifier has to be able to handle a peak voltage swing of

$$V_{L\text{peak}} = 1.4 \times 5.33 = 7.5V \text{ or } 15V_{(p-p)}$$

If other factors, such as transformer loss or even higher peak to average ratios are allowed for, this means the amplifiers must each swing between 16 to $18V_{(p-p)}$.

The required signal swing can be reduced by using a step-up transformer to drive the line. For example a 1:2 ratio will reduce the peak swing requirement by half, and this would allow the supply to be reduced by a corresponding amount. This is not recommended for the LM7372 in this particular application for two reasons. Although the quiescent power contribution to the overall dissipation is reduced by about 150mW, the internal power dissipation to drive the load remains the same, since the load for each amplifier is now 25Ω instead of 100Ω . Furthermore, this is a transceiver application where downstream signals are simultaneously appearing at the transformer secondary. The downstream signals appear differentially across the back termination resistors and are now stepped down by the transformer turns ratio with a consequent loss in receiver sensitivity compared to using a 1:1 transformer. Any trade-off to reduce the supply voltage by an increase in turns ratio should bear these factors in mind, as well as the increased signal current levels required with lower impedance loads.

At an elevated ambient temperature of 85°C and with an average power dissipation of 464mW, a package thermal resistance between 60°C/W and 80°C/W will be needed to keep the maximum junction temperature in the range 110°C to 120°C . The PSOP or LLP package would be the package of choice here with ample board copper area to aid in heat dissipation (see table 2).

For most standard surface mount packages, SO-8, SO-14, SO-16 etc, the only means of heat removal from the die is through the bond wires to external copper connecting to the leads. Usually it will be difficult to reduce the thermal resis-

Application Notes (Continued)

tance of these packages below 100°C/W by these methods and several manufacturers, including National, offer package modifications to enhance the thermal characteristics.

Improved removal of internal heat can be achieved by directly connecting bond wires to the lead frame inside the package. Since this lead frame supports the die attach paddle, heat is transferred directly from the substrate to the outside copper by these bond wires. For an 8 pin package, this enhancement is somewhat limited since only the V-bond wire can be used, because it is the only lead at the same voltage as the substrate and there is an electrical connection as well as a thermal connection.

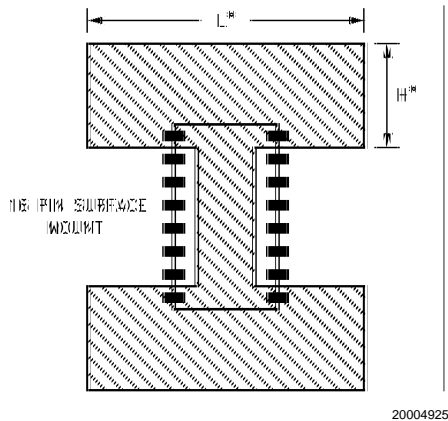

FIGURE 2. Copper Heatsink Patterns

The LM7372 is available in the SOIC-16 package. Since only 8 pins are needed for the two operational amplifiers, the remaining pins are used for heat sink purposes. Each of the end pins, 1,8,9 & 16 are internally bonded to the lead frame and form an effective means of transferring heat to external copper. This external copper can be either electrically isolated or be part of the topside ground plane in a single supply application.

Figure 2. shows a copper pattern which can be used to dissipate internal heat from the LM7372. Table 1 gives some values of θ_{JA} for different values of L and H with 1oz copper.

TABLE 1. Thermal Resistance with Area of Cu

Package	L (in)	H (in)	θ_{JA} (°C/W)
SOIC 16	1	0.5	83
SOIC 16	2	1	70
SOIC 16	3	1.5	67

From Table 1 it is apparent that two areas of 1oz copper at each end of the package, each 2 in² in area (for a total of 2600mm²) will be sufficient to hold the maximum junction temperature under 120°C with an 85°C ambient temperature.

An even better package for removing internally generated heat is a package with an exposed die attach paddle. The LM7372 is also available in the 8 lead LLP and PSOP packages. For these packages the entire lower surface of the paddle is not covered with plastic, which would otherwise act as a thermal barrier to heat transfer. Heat is transferred directly from the die through the paddle rather than through

the small diameter bonding wires. Values of θ_{JA} in °C/W for the LLP package with various areas and weights of copper are tabulated below.

TABLE 2. Thermal Resistance of LLP Package

Copper	Area	0.5 in ²	1.0 in ²	2.0 in ²
Top Layer Only	0.5 oz	115	105	102
	1.0 oz	91	79	72
	2.0 oz	74	60	52
Bottom Layer Only	0.5 oz	102	88	81
	1.0 oz	92	75	65
	2.0 oz	85	66	54
Top And Bottom	0.5 oz	83	70	63
	1.0 oz	71	57	47
	2.0 oz	63	48	37

Table 2 clearly demonstrates the superior thermal qualities of the exposed pad package. For example, using the topside copper only in the same way as shown for the SOIC package (Figure 2), with the L dimension held at 1 inch, the LLP requires half the area of 1 oz copper at each end of the package (1 in², for a total of 1300mm²), for a comparable thermal resistance of 72°C/Watt. This gives considerably more flexibility in the pcb layout aside from using less copper.

The shape of the heat sink shown in Figure 2 is necessary to allow external components to be connected to the package pins. If thermal vias are used beneath the LLP to the bottom side ground plane, then a square pattern heat sink can be used and there is no restriction on component placement on the top side of the board. Even better thermal characteristics are obtained with bottom layer heatsinking. A 2 inch square of 0.5oz copper gives the same thermal resistance (81°C/W) as a competitive thermally enhanced SO-8 package which needs two layers of 2 oz copper, each 4 in² (for a total of 5000 mm²). With heavier copper, thermal resistances as low as 54°C/W are possible with bottom side heatsinking only, substantially improving the long term reliability since the maximum junction temperature is held to less than 110°C, even with an ambient temperature of 85°C. If both top and bottom copper planes are used, the thermal resistance can be brought to under 40°C/W.

Power Supplies

The LM7372 is fabricated on a high voltage, high speed process. Using high supply voltages ensures adequate headroom to give low distortion with large signal swings. In Figure 1, a single 24V supply is used. To maximize the output dynamic range the non-inverting inputs are biased to half supply voltage by the resistive divider R1, R2. The input signals are AC coupled and the coupling capacitors (C1, C2) can be scaled with the bias resistors (R3, R4) to form a high pass filter if unwanted coupling from the POTS signal occurs.

Supply decoupling is important at both low and high frequencies. The 10µF Tantalum and 0.1µF Ceramic capacitors should be connected close to the supply Pin 14. Note that the V⁻ pin (pin 6), and the PCB area associated with the heatsink (Pins 1,8,9 & 16) are at the same potential. Any layout should avoid running input signal leads close to this ground plane, or unwanted coupling of high frequency supply currents may generate distortion products.

Although this application shows a single supply, conversion to a split supply is straightforward. The half supply resistive

Application Notes (Continued)

divider network is eliminated and the bias resistors at the non-inverting inputs are returned to ground, see *Figure 3* (the pin numbers in *Figure 3* are given for the LLP and PSOP packages, those in *Figure 1* are for the SOIC package). With a split supply, note that the ground plane and the heatsink copper must be separate and are at different potentials, with the heatsink (pin 4 of the LLP and PSOP, pins 6, 1, 8, 9 & 16 of the SOIC) now at a negative potential (V^-).

In either configuration, the area under the input pins should be kept clear of copper (Whether ground plane copper or heatsink copper) to avoid parasitic coupling to the inputs.

The LM7372 is stable with non inverting closed loop gains as low as +2. Typical of any voltage feedback operational amplifier, as the closed loop gain of the LM7372 is increased, there is a corresponding reduction in the closed loop signal bandwidth. For low distortion performance it is recommended to keep the closed loop bandwidth at least 10X the highest signal frequency. This is because there is less loop gain (the difference between the open loop gain and the closed loop gain) available at higher frequencies to reduce harmonic distortion terms.

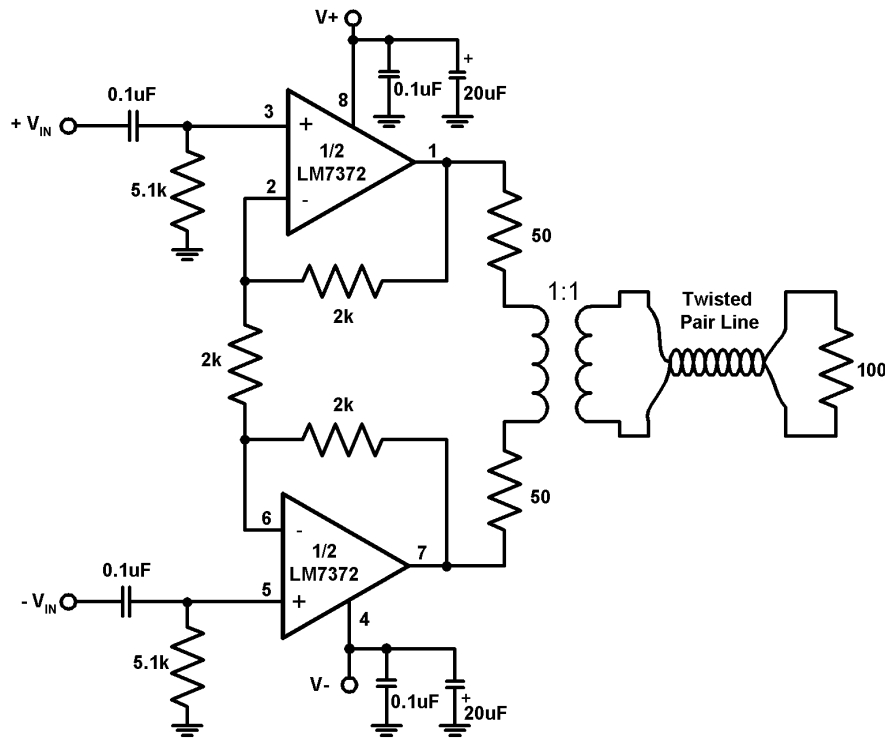

20004926

FIGURE 3. Split Supply Application (LLP)

Printed Circuit Board Layout and Evaluation Boards:

Generally, a good high-frequency layout will keep power supply and ground traces away from the inverting input and output pins. Parasitic capacitance on these nodes to ground will cause frequency response peaking and possible circuit oscillations (see Application Note OA-15 for more information). National Semiconductor suggests the following evaluation boards as a guide for high frequency layout and as an aid in device testing and characterization:

Device	Package	Evaluation Board PN
LM7372MA	16-Pin SOIC	None
LM7372ILD	8-Pin LLP	CLC730114
LM7372MR	8-Pin PSOP	CLC730121

These free evaluation boards are shipped automatically when a device sample request is placed with National Semiconductor.

The DAP (die attach paddle) on the LLP-8, and the PSOP should be tied to V^- . It should not be tied to ground. See respective Evaluation Board documentation.

Physical Dimensions inches (millimeters)
unless otherwise noted

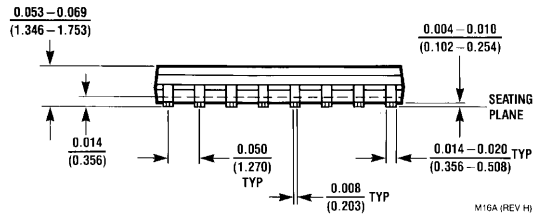
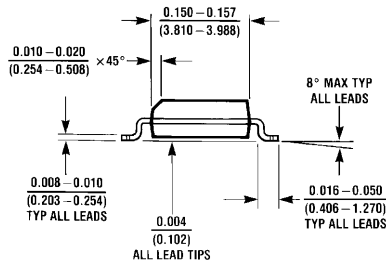
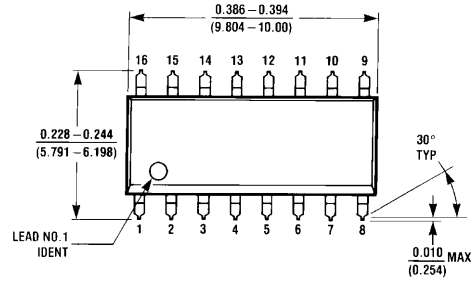

16-Pin SOIC
NS Package Number M16A

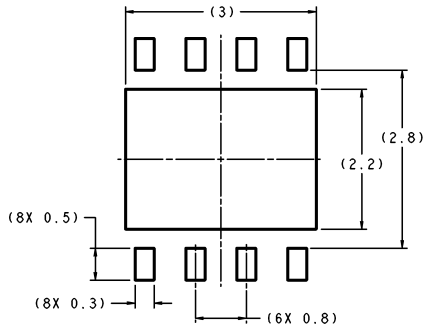

RECOMMENDED LAND PATTERN
1:1 RATION WITH PKG SOLDER PADS

DIMENSIONS ARE IN MILLIMETERS

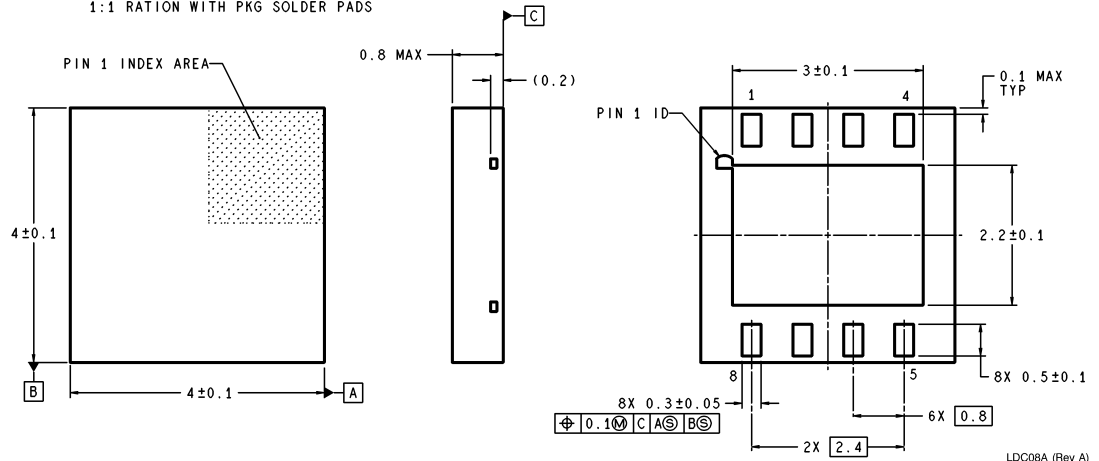

8-Pin LLP
NS Package Number LDC08A

Physical Dimensions inches (millimeters) unless otherwise noted (Continued)

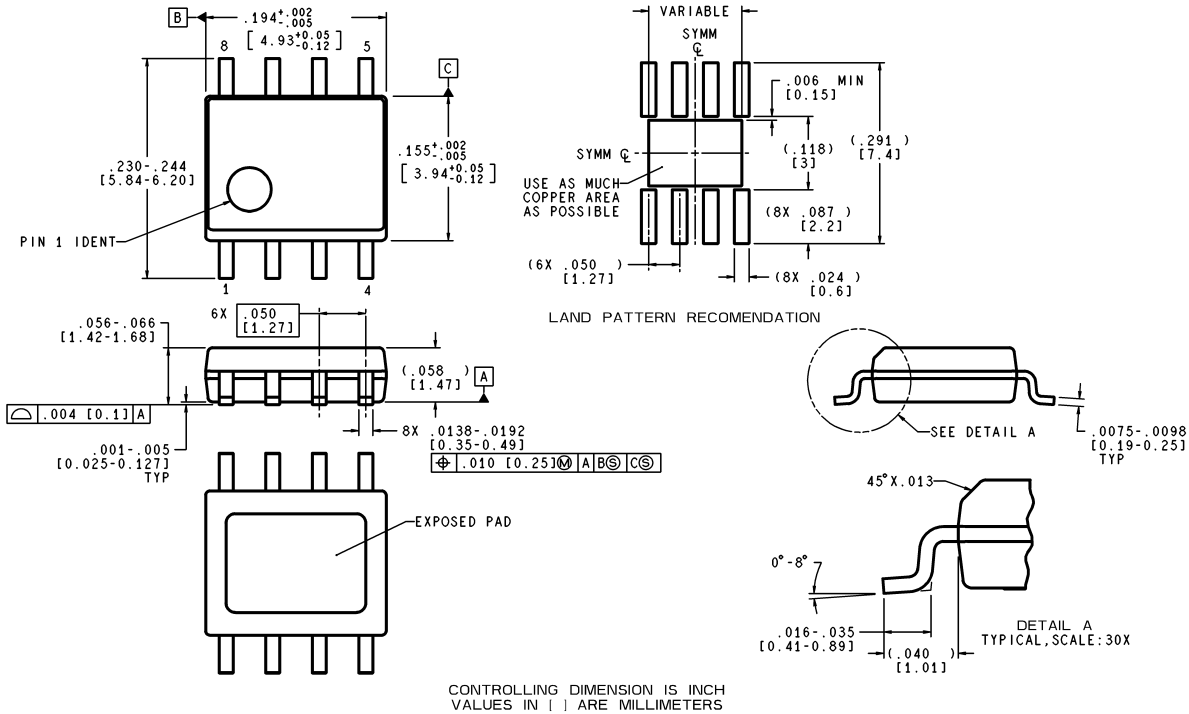

**8-Pin PSOP
NS Package Number MRA08A**

LIFE SUPPORT POLICY

NATIONAL'S PRODUCTS ARE NOT AUTHORIZED FOR USE AS CRITICAL COMPONENTS IN LIFE SUPPORT DEVICES OR SYSTEMS WITHOUT THE EXPRESS WRITTEN APPROVAL OF THE PRESIDENT AND GENERAL COUNSEL OF NATIONAL SEMICONDUCTOR CORPORATION. As used herein:

1. Life support devices or systems are devices or systems which, (a) are intended for surgical implant into the body, or (b) support or sustain life, and whose failure to perform when properly used in accordance with instructions for use provided in the labeling, can be reasonably expected to result in a significant injury to the user.
2. A critical component is any component of a life support device or system whose failure to perform can be reasonably expected to cause the failure of the life support device or system, or to affect its safety or effectiveness.

National Semiconductor Corporation
Americas
Email: support@nsc.com

National Semiconductor Europe
Fax: +49 (0) 180-530 85 86
Email: europe.support@nsc.com
Deutsch Tel: +49 (0) 69 9508 6208
English Tel: +44 (0) 870 24 0 2171
Français Tel: +33 (0) 1 41 91 8790

National Semiconductor Asia Pacific Customer Response Group
Tel: 65-2544466
Fax: 65-2504466
Email: ap.support@nsc.com

National Semiconductor Japan Ltd.
Tel: 81-3-5639-7560
Fax: 81-3-5639-7507

www.national.com