

DATA SHEET

TZA1015

Data amplifier and laser supply
circuit for CD and read-only optical
systems (HDALAS)

Product specification
Supersedes data of 1998 Sep 09
File under Integrated Circuits, IC01

1999 Aug 19

Data amplifier and laser supply circuit for CD and read-only optical systems (HDALAS)

TZA1015

FEATURES

- Six input buffer amplifiers with low-pass filtering and virtually no offset
- Universal photodiode IC interface using internal conversion resistors
- RF data amplifier with wide bandwidth designed for data rates up to a maximum of 30x
- Programmable RF gain for CD-A/V, CD-R, CD-R/W and CD-ROM applications
- Programmable RF bandwidth for optimal playability
- Radial error signal for fast track counting
- Programmable RF/Fast Track Count (FTC) gain for optimal dynamic range
- Fully automatic laser control including stabilization and on/off switch plus a separate supply for power efficiency
- Automatic monitor diode polarity selection
- Adjustable laser bandwidth and laser switch-on current slope using external capacitor
- Protection circuit to prevent laser damage due to supply voltage dip
- Optimized interconnection between data amplifier and Philips' digital signal processor family (CD7, ACE and MACE)
- Wide supply voltage range
- Wide temperature range
- Low power consumption.

GENERAL DESCRIPTION

The TZA1015 is a data amplifier and laser supply circuit for 3-beam pick-up detectors found in a wide range of CD and read-only optical systems.

The device contains 6 transimpedance amplifiers to amplify and filter the focus and radial photo diode voltage input signals. The preamplifier forms a versatile, programmable interface from voltage output CD mechanisms to the Philips' digital signal processor family.

The dynamic range of this preamplifier/processor combination can be optimized for the LF servo and RF data paths. The servo channel gain is set by the ADC range of the processor. The RF data channel can be programmed in the TZA1015 preamplifier.

The programmable RF bandwidth allows this device to be used in CD-A/V applications or CD-R, CD-R/W and CD-ROM applications with a data rate up to a maximum of 30x. The RF and LF gain can be adapted for CD-A/V, CD-R and CD-ROM discs or CD-R/W discs by means of a gain switch. In addition to this gain switch the RF gain is programmable to guarantee optimal playability. In order to enable minimal access time the TZA1015 generates a Fast Track Count signal which enables the decoder (ACE or MACE) to count the number of tracks during a track jump.

The device can accommodate astigmatic, single Foucault and double Foucault detectors and can be used with all laser and N- or P-sub monitor diodes. The Automatic Laser Power Control (ALPC) circuit will maintain control over the laser diode current. With an on-chip reference voltage generator, a constant and stabilized output power is ensured independent of ageing. A separate power supply connection allows the internal power dissipation to be reduced by connecting a low voltage supply.

ORDERING INFORMATION

TYPE NUMBER	PACKAGE		
	NAME	DESCRIPTION	VERSION
TZA1015T	SO28	plastic small outline package; 28 leads; body width 7.5 mm	SOT136-1

Data amplifier and laser supply circuit for CD and read-only optical systems (HDALAS)

TZA1015

QUICK REFERENCE DATA

SYMBOL	PARAMETER	CONDITIONS	MIN.	TYP.	MAX.	UNIT
Supply						
$V_{DD(RF,LF)}$	supply voltage		4.5	5.0	5.5	V
$V_{DD(L)}$	laser supply voltage		3	–	5.5	V
LF amplifiers						
I_{OS}	channel matching		–	–	1	%FS
$B_{(-3dB)}$	–3 dB bandwidth		65	90	115	kHz
RF amplifier						
$B_{(-3dB)}$	–3 dB bandwidth	programmable; GARF = open-circuit	–	10	–	MHz
			–	20	–	MHz
			–	50	–	MHz
$t_{d(f)(RF)}$	RF flatness delay		–	–	0.4	ns
Laser supply						
$I_{o(LASER)(min)}$	minimum laser output current	$V_{DD(L)} = 3\text{ V}$	–	–	100	mA
$V_{i(mon)}$	monitor input voltage		–	0.150	–	V
	N-type monitor		–	$V_{DD(RF,LF)} - 0.150$	–	V
	P-type monitor		–	$V_{DD(RF,LF)} - 0.150$	–	V
Temperature range						
T_{oper}	operating temperature		0	–	85	°C
T_{stg}	storage temperature		–65	–	+150	°C

Data amplifier and laser supply circuit for CD and read-only optical systems (HDALAS)

TZA1015

BLOCK DIAGRAM

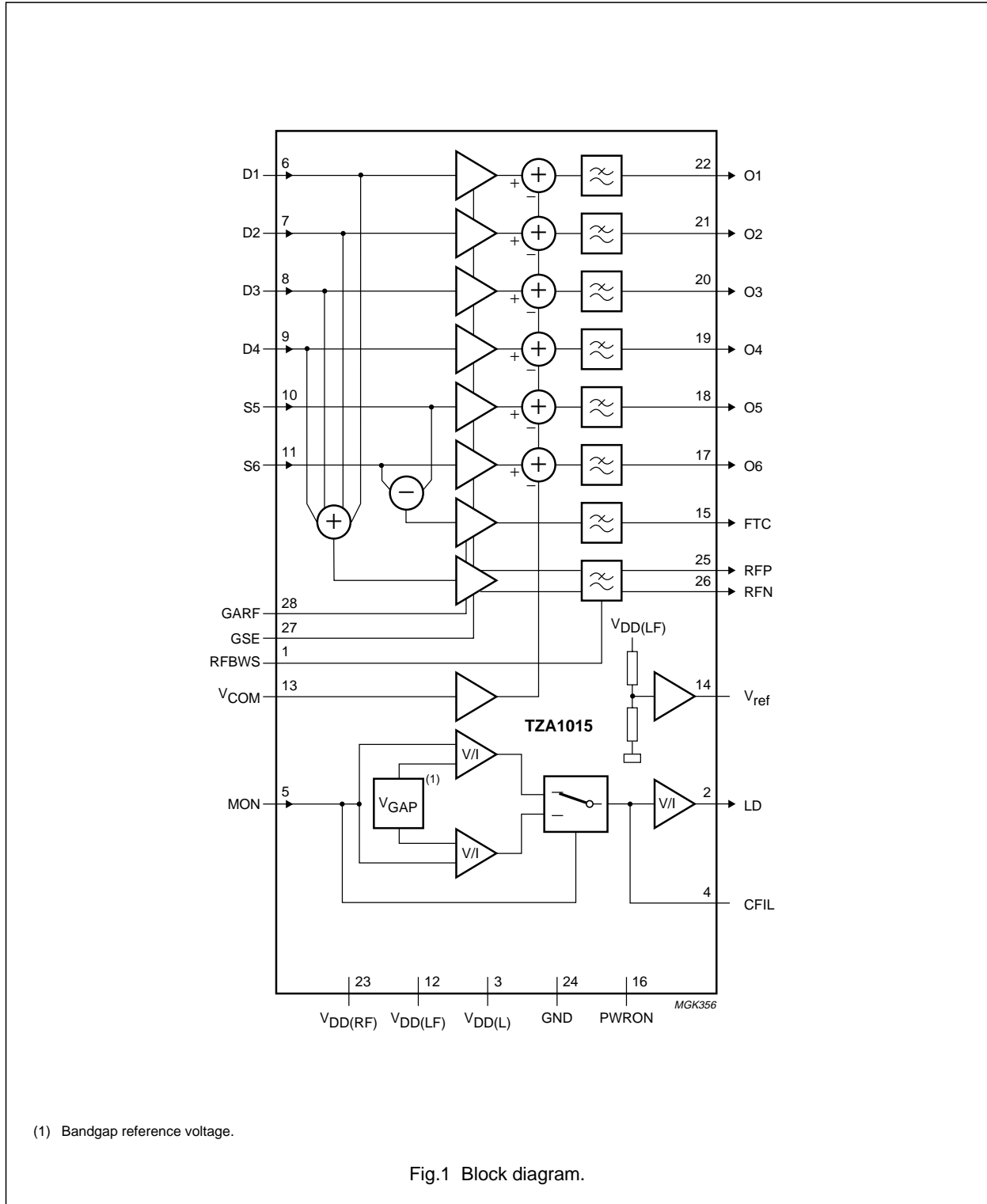

(1) Bandgap reference voltage.

Fig.1 Block diagram.

Data amplifier and laser supply circuit for CD and read-only optical systems (HDALAS)

TZA1015

PINNING

SYMBOL	PIN	DESCRIPTION
RFBWS	1	RF amplifier bandwidth select
LD	2	current output to the laser diode
$V_{DD(L)}$	3	laser supply voltage
CFIL	4	external filter capacitor
MON	5	laser monitor diode input
D1	6	input photo diode amplifier 1 (central)
D2	7	input photo diode amplifier 2 (central)
D3	8	input photo diode amplifier 3 (central)
D4	9	input photo diode amplifier 4 (central)
S5	10	input photo diode amplifier 5 (satellite)
S6	11	input photo diode amplifier 6 (satellite)
$V_{DD(LF)}$	12	LF diode and FTC amplifier supply voltage
V_{COM}	13	common mode DC reference input
V_{ref}	14	DC reference voltage for biasing of Opto Electronic IC (OEIC)
FTC	15	fast track count amplifier output
PWRON	16	power on/off switch (V_{ref} bias generator always active)
O6	17	output photo diode amplifier 6
O5	18	output photo diode amplifier 5
O4	19	output photo diode amplifier 4
O3	20	output photo diode amplifier 3
O2	21	output photo diode amplifier 2
O1	22	output photo diode amplifier 1
$V_{DD(RF)}$	23	RF amplifier supply voltage
GND	24	ground
RFP	25	positive output RF data amplifier
RFN	26	negative output RF data amplifier
GSE	27	gain select for CD, CD-R, CD-R/W; RF and FTC amplifiers
GARF	28	gain adjust for RF and FTC amplifiers

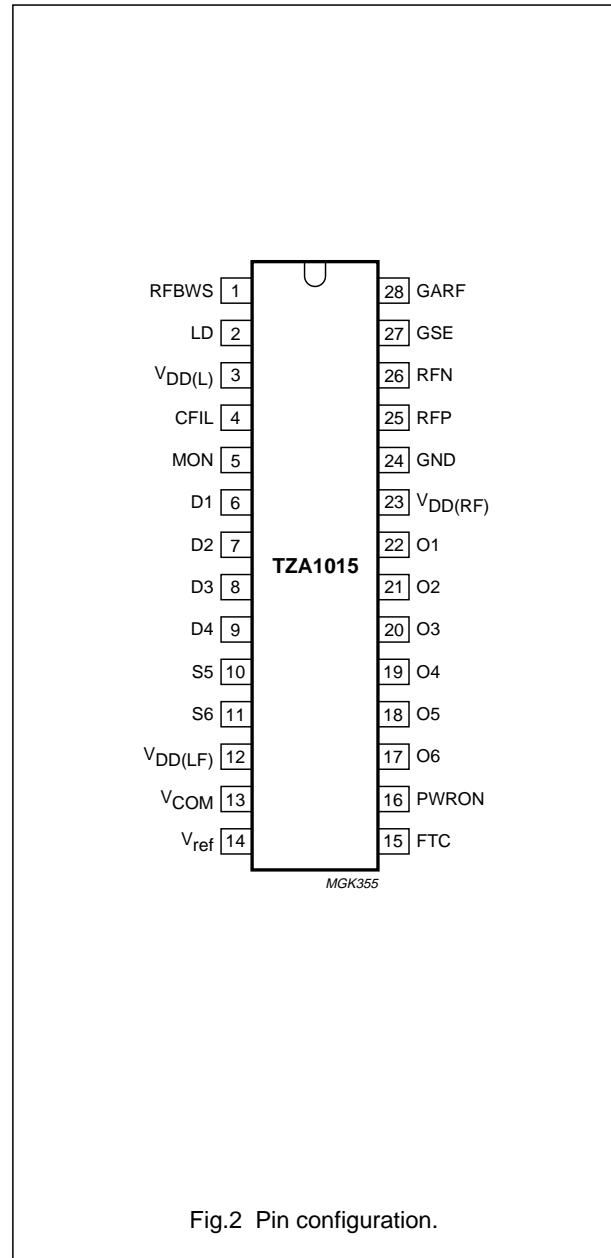

Data amplifier and laser supply circuit for CD and read-only optical systems (HDALAS)

TZA1015

LIMITING VALUES

In accordance with the Absolute Maximum Rating System (IEC 134).

SYMBOL	PARAMETER	CONDITIONS	MIN.	MAX.	UNIT
$V_{DD(RF,LF)}$	supply voltage		-0.5	+5.5	V
$V_{I(n)}$	input voltage for all pins		-0.5	$V_{DD(RF,LF)} + 0.5$	V
I_{source}	source current				
	pin FTC		-	4	mA
	pin RFP		-	2	mA
	pin RFN		-	2	mA
T_{amb}	operating ambient temperature		-40	+100	°C
P_{max}	maximum power dissipation	note 1	-	700	mW

Note

- Based on standard measurement for determining thermal resistance of the package. In accordance with MIL-STD 883C.

CHARACTERISTICS

$V_{DD(LF)} = V_{DD(RF)} = V_{DD(L)} = 5.0$ V; $T_{amb} = 25$ °C; PWRON = HIGH; GSE = LOW; GARF = open-circuit; RFBWS = HIGH; DC input voltages at pins V_{COM} , D1 to D4, S5 and S6 = $\frac{1}{2}V_{DD}$; output voltage at pins O1 to O6 = 0 V; $I_{DD(L)(d)} = 50$ mA; $C_{CFIL} = 1$ nF; unless otherwise specified. Diode input voltages all with respect to V_{COM} .

SYMBOL	PARAMETER	CONDITIONS	MIN.	TYP.	MAX.	UNIT
Supplies						
$V_{DD(RF,LF)}$	supply voltage		4.5	5.0	5.5	V
$V_{DD(L)}$	laser supply voltage		3	-	5.5	V
$I_{DD(LF)}$	LF supply current		-	13	-	mA
$I_{DD(RF)}$	RF supply current		-	20	-	mA
$I_{DD(L)(d)}$	laser diode supply current		-	50	100	mA
I_q	quiescent supply current	PWRON = LOW	-	-	6	mA
Input voltages						
$V_{I(D1-D4,S5,S6)}$	input signal voltage range (with respect to V_{COM})	all inputs; GSE = LOW	0	-	0.6	V
		all inputs; GSE = HIGH	0	-	0.15	V
$V_{I(CM)}$	common mode DC reference input voltage range		1.6	-	$V_{DD(RF,LF)} - 2.2$	V

Data amplifier and laser supply circuit for CD and read-only optical systems (HDALAS)

TZA1015

SYMBOL	PARAMETER	CONDITIONS	MIN.	TYP.	MAX.	UNIT
LF diode amplifiers						
Z_{CONV}	conversion impedance					
	central diodes, D1 to D4	GSE = LOW	40	47	54	k Ω
		GSE = HIGH	10.5	12.5	15.0	k Ω
	satellite diodes, S5 and S6	GSE = LOW	75	92	106	k Ω
		GSE = HIGH	20.5	24.5	28	k Ω
$I_{\text{o(LF)}}$	output current range	note 1				
	central diodes, O1 to O4		0	–	12	μA
	satellite diodes, O5 and O6		0	–	6	μA
$V_{\text{O(LF)}}$	DC output voltage range central and satellite diodes		–0.2	–	$V_{\text{DD(RF,LF)}} - 2.1$	V
Z_{i}	input impedance					
	central diodes		–	3.1	–	pF
	satellite diodes		–	3.1	–	pF
I_{OS}	channel pair matching	note 2				
	central diodes, O1 to O4		–1	–	+1	%FS
	satellite diodes, O5 and O6		–2	–	+2	%FS
$B_{(-3\text{dB})}$	–3 dB bandwidth					
	central diodes, D1 to D4		65	90	115	kHz
	satellite diodes, S5 and S6		65	90	115	kHz
RF amplifier						
$V_{\text{O(RFP)}}$	DC output level RFP	GSE = LOW or HIGH; $V_{\text{i(D1 to D4)}} = 0 \text{ V}$	0.25	0.5	0.7	V
$V_{\text{O(RFN)}}$	DC output level RFN	GSE = LOW or HIGH; $V_{\text{i(D1 to D4)}} = 0 \text{ V}$	2.6	3.1	3.4	V
$V_{\text{O(RF)(dif)}}$	differential RF output signal ($V_{\text{O(RFP)}} - V_{\text{O(RFN)}}$)	note 3	–	2	–	V
$V_{\text{O(RF)}}$	single-sided RF output signal	note 3	–	1	–	V
$Z_{\text{O(RF)}}$	RF output impedance		–	25	–	Ω

Data amplifier and laser supply circuit for CD and read-only optical systems (HDALAS)

TZA1015

SYMBOL	PARAMETER	CONDITIONS	MIN.	TYP.	MAX.	UNIT
G_{RF}	RF path gain	note 4 GSE = LOW GSE = HIGH	9 21	10.5 22.5	12 24	dB dB
$t_{d(f)(RF)}$	RF flatness delay	GSE = LOW or HIGH; note 5 f < 5 MHz; RFBWS = LOW f < 10 MHz; RFBWS = open-circuit f < 25 MHz; RFBWS = HIGH	– – –	– – –	2.0 1.0 0.4	ns ns ns
$B_{RF(-3dB)}$	–3 dB bandwidth (RF signal)	GSE = LOW or HIGH RFBWS = LOW RFBWS = open-circuit RFBWS = HIGH	– – –	10 20 50	– – –	MHz MHz MHz
$V_{n(in-band)(rms)}$	in-band noise (RMS value)	RFBWS = LOW RFBWS = open-circuit RFBWS = HIGH	– – –	1.0 1.4 2.1	– – –	mV mV mV
$V_{O(FTC)}$	fast track count DC output level	GSE = LOW or HIGH; note 6	1.3	1.5	1.7	V
G_{FTC}	fast track count gain	f = 100 kHz; note 7 GSE = LOW GSE = HIGH	16.5 26.5	18 28	19.5 29.5	dB dB
$B_{FTC(-3dB)}$	fast track count –3 dB bandwidth		220	300	380	kHz
Laser supply (APC)						
$I_{o(LASER)(min)}$	minimum laser output current		–	–	100	mA
$V_{i(mon)}$	monitor input voltage N-type P-type		–10% –	0.150 $V_{DD(RF,LF)} - 0.150$	+13.5% –	V V
$V_{o(LASER)}$	laser output voltage range	$I_{o(LASER)} = 100 \text{ mA}$	–	–	$V_{DD(L)} - 1.2$	V
$t_{sw(on)(LASER)}$	laser switch-on time		–	3	–	ms
$I_{i(mon)}$	monitor input current		–	–	100	nA

Data amplifier and laser supply circuit for CD
and read-only optical systems (HDALAS)

TZA1015

SYMBOL	PARAMETER	CONDITIONS	MIN.	TYP.	MAX.	UNIT
Control inputs						
$Z_{i(pd)}$	pull-down input impedance (pin GSE)		–	150	–	k Ω
$Z_{i(pu)}$	pull-up input impedance (pin PWRON)		–	150	–	k Ω
V_{IL}	LOW-level input voltage pins GSE and PWRON		–0.2	–	$\frac{V_{DD(RF,LF)}}{3.3}$	V
	pins GARF and RFBWS		–0.2	–	+0.5	V
V_{IH}	HIGH-level input voltage pins GSE and PWRON		$\frac{V_{DD(RF,LF)}}{1.4}$	–	$V_{DD(RF,LF)} + 0.2$	V
	pins GARF and RFBWS		$V_{DD(RF,LF)} - 0.5$	–	$V_{DD(RF,LF)} + 0.2$	V
I_{IL}	LOW-level input current (pins GARF and RFBWS)		–	–	–70	μ A
I_{IH}	HIGH-level input current (pins GARF and RFBWS)		–	–	80	μ A
V_{ref} voltage source						
V_O	DC output voltage		–10%	$\frac{V_{DD(RF,LF)}}{2}$	+10%	V
I_O	output current range					
	sink		1.5	–	–	mA
	source		–	–	–3	mA
Z_O	DC output impedance		–	–	30	Ω

Data amplifier and laser supply circuit for CD and read-only optical systems (HDALAS)

TZA1015

Notes

1. The output current can be increased but does not match the default input range of the servo system.
2. Matching defined in % of FS output per channel pairs (O1 – O2), (O3 – O4), (S5 – S6), at $\frac{1}{3}$ and $\frac{2}{3}$ of full output scale.
3. $V_{o(RFP)} = V_{o(RF)}$; $V_{o(RFN)} = -V_{o(RF)}$.

$$4. \text{ Gain is defined as: } G_{RF} = 20 \times \log \left[\frac{V_{o(RFP)}}{V_{i(LF)}} \right] = 20 \times \log \left[\frac{V_{o(RFN)}}{V_{i(LF)}} \right]$$

All inputs assumed to be equal: $V_{i(LF)} = \frac{\sum V_{i(D)}}{4}$, where $i = 1$ to 4 and D means diode.

5. See Figs 3, 4 and 5.
6. Voltage is based on 2 PN junctions and is temperature dependent.

$$7. \text{ Gain is defined as: } G_{FTC} = 20 \times \log \left[\frac{V_{o(FTC)}}{(V_{i(S5)} - V_{i(S6)})} \right]$$

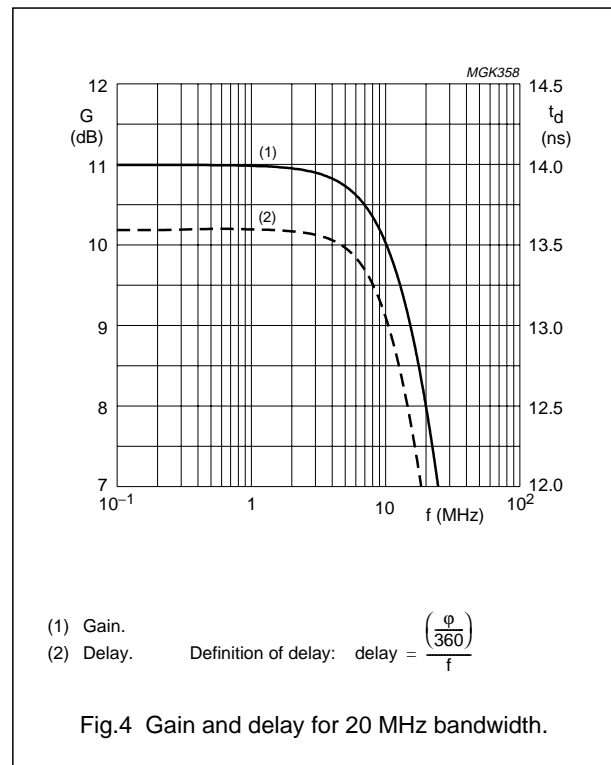
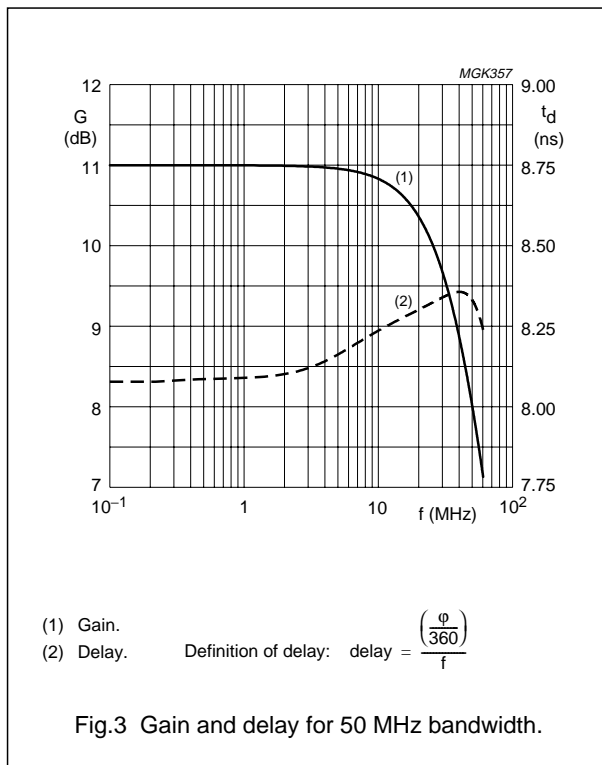

Data amplifier and laser supply circuit for CD and read-only optical systems (HDALAS)

TZA1015

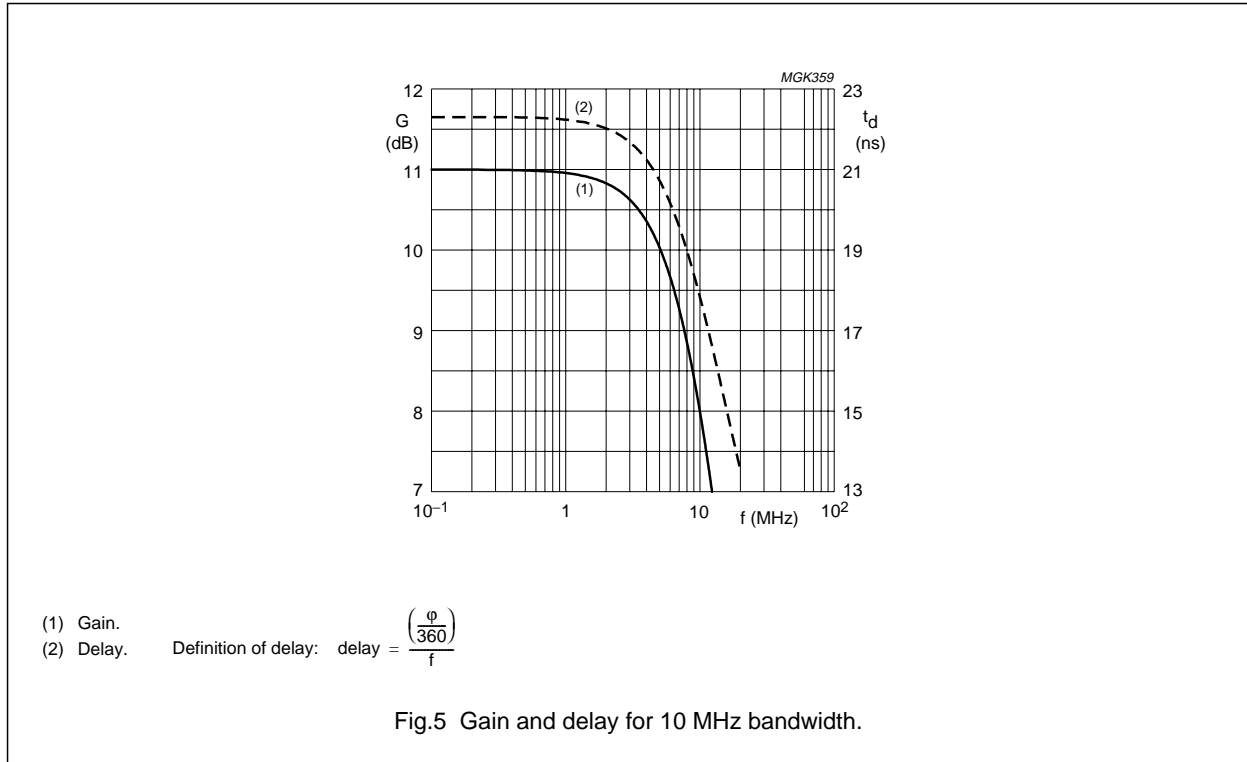

Table 1 Control inputs, conversion impedances and gain settings

PIN GSE	PIN GARF	NOMINAL LF V/I CONVERSION (CENTRAL DIODES)	NOMINAL LF V/I CONVERSION (SATELLITE DIODES)	NOMINAL RF GAIN (dB)	NOMINAL FTC GAIN (dB)
LOW	LOW	47 kΩ	92 kΩ	7	14
LOW	open-circuit	47 kΩ	92 kΩ	10.5	18
LOW	HIGH	47 kΩ	92 kΩ	15	22
HIGH	LOW	12.5 kΩ	24.5 kΩ	19	24
HIGH	open-circuit	12.5 kΩ	24.5 kΩ	22.5	28
HIGH	HIGH	12.5 kΩ	24.5 kΩ	27	32

Table 2 Control inputs and RF bandwidth

PIN RFBWS	RF AMPLIFIER BANDWIDTH
LOW	10 MHz
open-circuit	20 MHz
HIGH	50 MHz

Data amplifier and laser supply circuit for CD and read-only optical systems (HDALAS)

TZA1015

APPLICATION INFORMATION

The circuits shown in Figs 6 and 7 are applications for the TZA1015 (HDALAS) with the SAA7370A (CD7) or the SAA7348 (ACE).

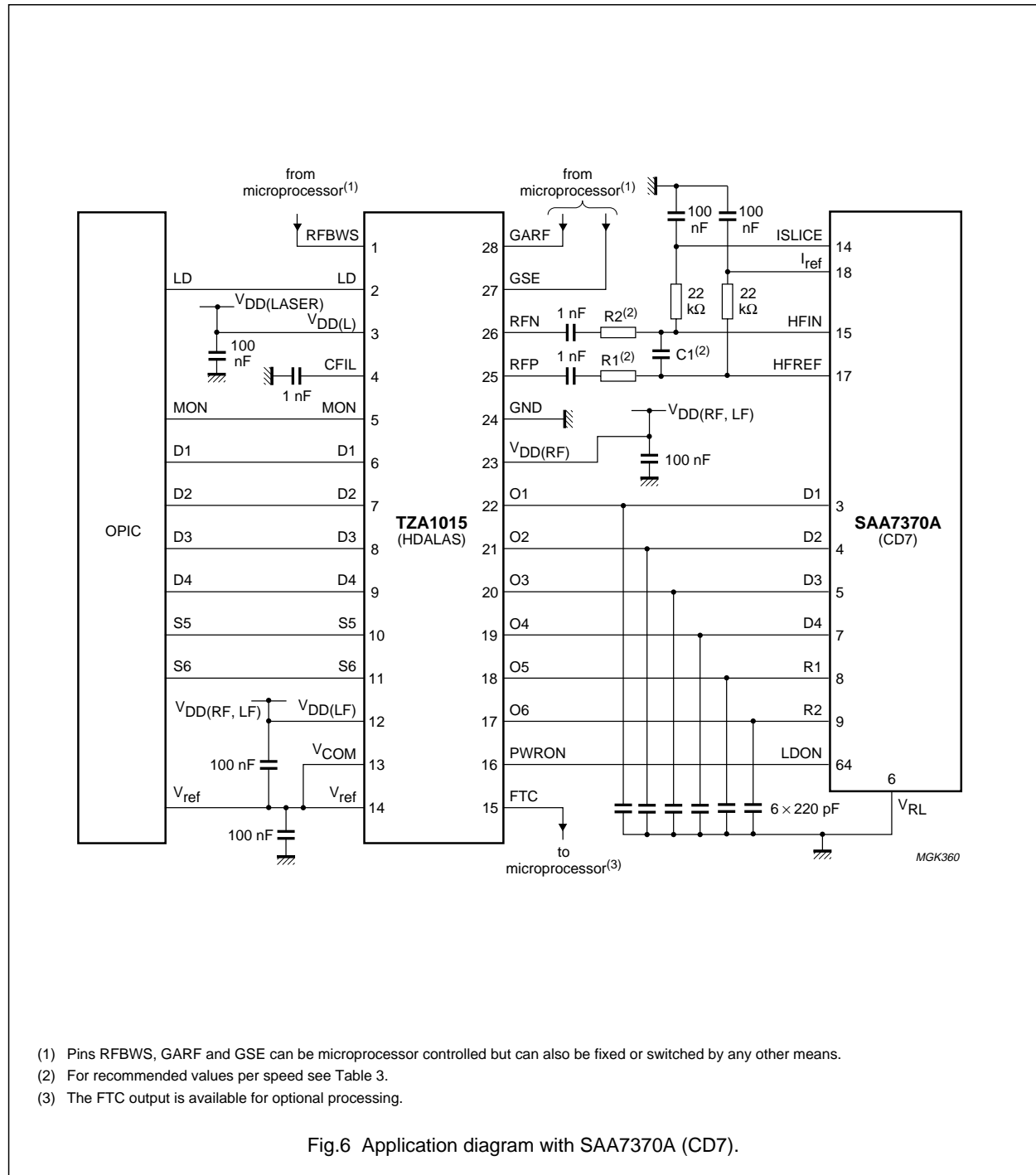

Data amplifier and laser supply circuit for CD and read-only optical systems (HDALAS)

TZA1015

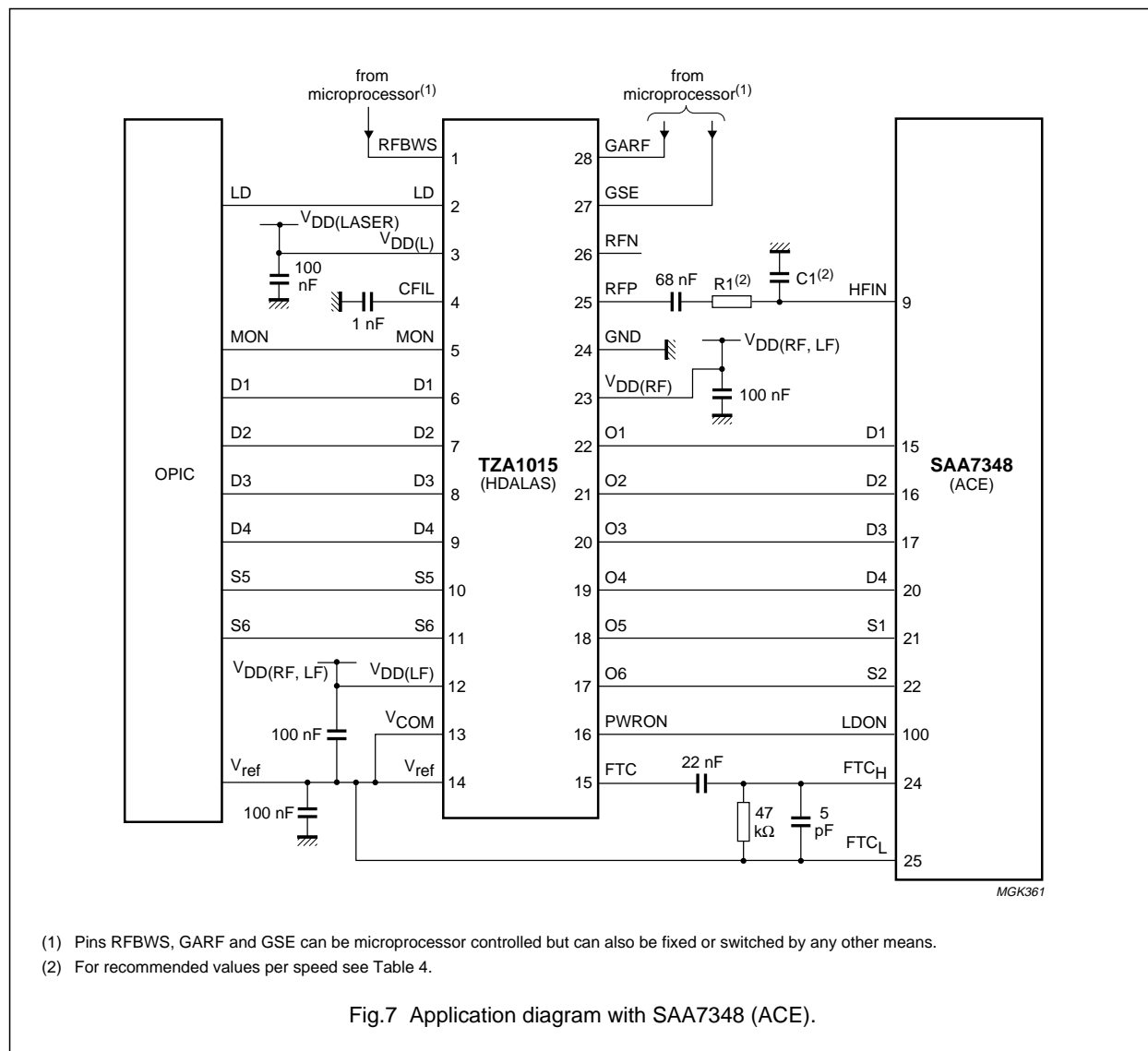

Table 3 Recommended values of components per speed for application diagram of Fig.6

N	C1	R1	R2
1x	47 pF	1 kΩ	1 kΩ
2x	47 pF	470 Ω	470 Ω
4x	22 pF	470 Ω	470 Ω
8x	10 pF	470 Ω	470 Ω
10x	8.2 pF	470 Ω	470 Ω

Table 4 Recommended values of components per speed for application diagram of Fig.7

N	C1	R1
1x	100 pF	1 kΩ
2x	47 pF	1 kΩ
4x	22 pF	1 kΩ
8x	22 pF	470 Ω
16x	10 pF	470 Ω
18x	6.8 pF	470 Ω

Data amplifier and laser supply circuit for CD and read-only optical systems (HDALAS)

TZA1015

PACKAGE OUTLINE

SO28: plastic small outline package; 28 leads; body width 7.5 mm

SOT136-1

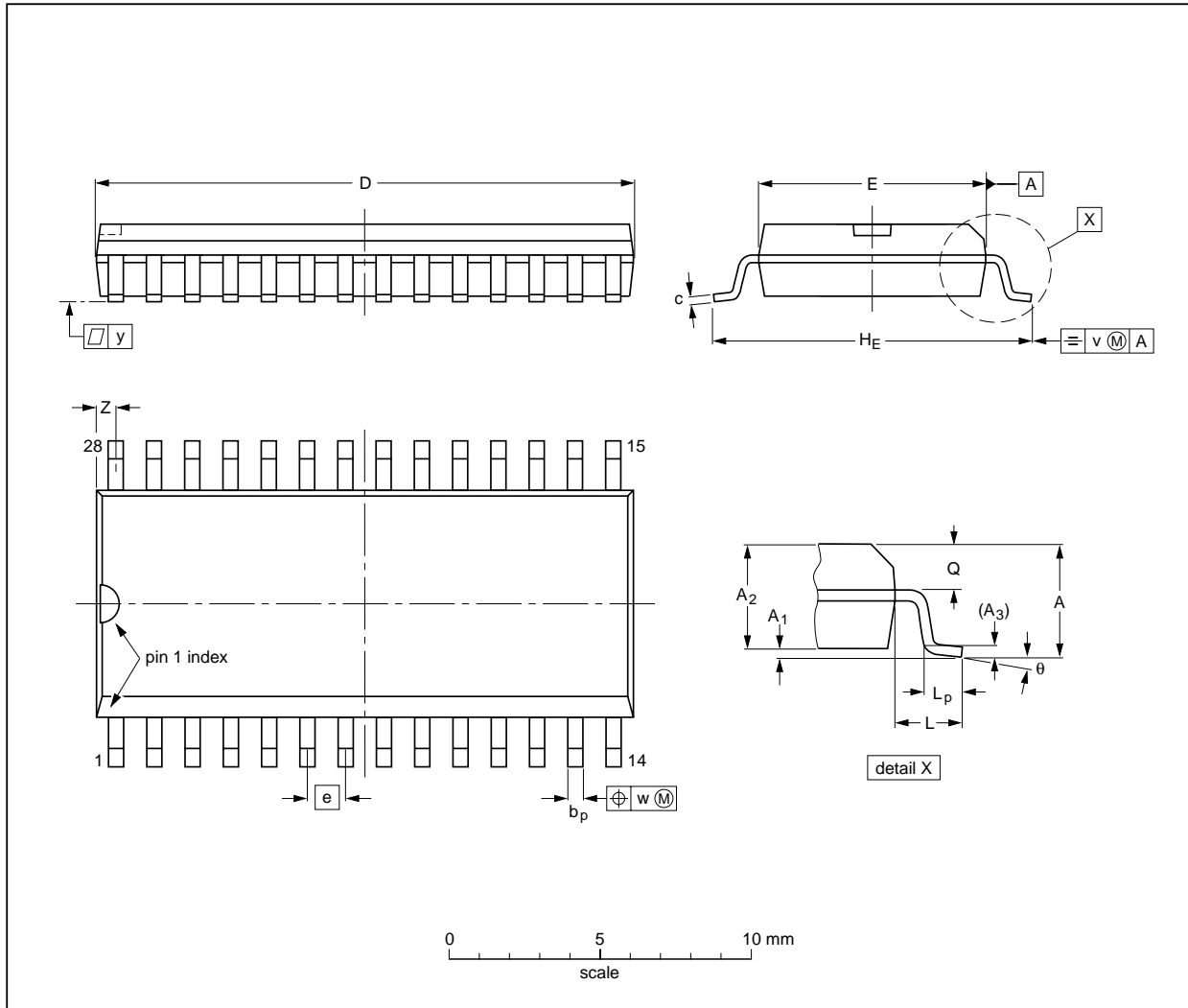

DIMENSIONS (inch dimensions are derived from the original mm dimensions)

UNIT	A max.	A ₁	A ₂	A ₃	b _p	c	D ⁽¹⁾	E ⁽¹⁾	e	H _E	L	L _p	Q	v	w	y	Z ⁽¹⁾	θ
mm	2.65	0.30 0.10	2.45 2.25	0.25	0.49 0.36	0.32 0.23	18.1 17.7	7.6 7.4	1.27	10.65 10.00	1.4	1.1 0.4	1.1 1.0	0.25	0.25	0.1	0.9 0.4	8° 0°
inches	0.10	0.012 0.004	0.096 0.089	0.01	0.019 0.014	0.013 0.009	0.71 0.69	0.30 0.29	0.050	0.419 0.394	0.055	0.043 0.016	0.043 0.039	0.01	0.01	0.004	0.035 0.016	

Note

1. Plastic or metal protrusions of 0.15 mm maximum per side are not included.

OUTLINE VERSION	REFERENCES				EUROPEAN PROJECTION	ISSUE DATE
	IEC	JEDEC	EIAJ			
SOT136-1	075E06	MS-013AE				95-01-24 97-05-22

Data amplifier and laser supply circuit for CD and read-only optical systems (HDALAS)

TZA1015

SOLDERING

Introduction

There is no soldering method that is ideal for all IC packages. Wave soldering is often preferred when through-hole and surface mounted components are mixed on one printed-circuit board. However, wave soldering is not always suitable for surface mounted ICs, or for printed-circuits with high population densities. In these situations reflow soldering is often used.

This text gives a very brief insight to a complex technology. A more in-depth account of soldering ICs can be found in our *"Data Handbook IC26; Integrated Circuit Packages"* (order code 9398 652 90011).

Reflow soldering

Reflow soldering techniques are suitable for all SO packages.

Reflow soldering requires solder paste (a suspension of fine solder particles, flux and binding agent) to be applied to the printed-circuit board by screen printing, stencilling or pressure-syringe dispensing before package placement.

Several techniques exist for reflowing; for example, thermal conduction by heated belt. Dwell times vary between 50 and 300 seconds depending on heating method. Typical reflow temperatures range from 215 to 250 °C.

Preheating is necessary to dry the paste and evaporate the binding agent. Preheating duration: 45 minutes at 45 °C.

Wave soldering

Wave soldering techniques can be used for all SO packages if the following conditions are observed:

- A double-wave (a turbulent wave with high upward pressure followed by a smooth laminar wave) soldering technique should be used.
- The longitudinal axis of the package footprint must be parallel to the solder flow.
- The package footprint must incorporate solder thieves at the downstream end.

During placement and before soldering, the package must be fixed with a droplet of adhesive. The adhesive can be applied by screen printing, pin transfer or syringe dispensing. The package can be soldered after the adhesive is cured.

Maximum permissible solder temperature is 260 °C, and maximum duration of package immersion in solder is 10 seconds, if cooled to less than 150 °C within 6 seconds. Typical dwell time is 4 seconds at 250 °C.

A mildly-activated flux will eliminate the need for removal of corrosive residues in most applications.

Repairing soldered joints

Fix the component by first soldering two diagonally-opposite end leads. Use only a low voltage soldering iron (less than 24 V) applied to the flat part of the lead. Contact time must be limited to 10 seconds at up to 300 °C. When using a dedicated tool, all other leads can be soldered in one operation within 2 to 5 seconds between 270 and 320 °C.

Data amplifier and laser supply circuit for CD and read-only optical systems (HDALAS)

TZA1015

DEFINITIONS

Data sheet status	
Objective specification	This data sheet contains target or goal specifications for product development.
Preliminary specification	This data sheet contains preliminary data; supplementary data may be published later.
Product specification	This data sheet contains final product specifications.
Limiting values	
Limiting values given are in accordance with the Absolute Maximum Rating System (IEC 134). Stress above one or more of the limiting values may cause permanent damage to the device. These are stress ratings only and operation of the device at these or at any other conditions above those given in the Characteristics sections of the specification is not implied. Exposure to limiting values for extended periods may affect device reliability.	
Application information	
Where application information is given, it is advisory and does not form part of the specification.	

LIFE SUPPORT APPLICATIONS

These products are not designed for use in life support appliances, devices, or systems where malfunction of these products can reasonably be expected to result in personal injury. Philips customers using or selling these products for use in such applications do so at their own risk and agree to fully indemnify Philips for any damages resulting from such improper use or sale.

Data amplifier and laser supply circuit for CD
and read-only optical systems (HDALAS)

TZA1015

NOTES

Data amplifier and laser supply circuit for CD
and read-only optical systems (HDALAS)

TZA1015

NOTES

Data amplifier and laser supply circuit for CD
and read-only optical systems (HDALAS)

TZA1015

NOTES

Philips Semiconductors – a worldwide company

Argentina: see South America

Australia: 3 Figtree Drive, HOMEBUSH, NSW 2140,
Tel. +61 2 9704 8141, Fax. +61 2 9704 8139

Austria: Computerstr. 6, A-1101 WIEN, P.O. Box 213,
Tel. +43 1 60 101 1248, Fax. +43 1 60 101 1210

Belarus: Hotel Minsk Business Center, Bld. 3, r. 1211, Volodarski Str. 6,
220050 MINSK, Tel. +375 172 20 0733, Fax. +375 172 20 0773

Belgium: see The Netherlands

Brazil: see South America

Bulgaria: Philips Bulgaria Ltd., Energoproject, 15th floor,
51 James Bourchier Blvd., 1407 SOFIA,
Tel. +359 2 68 9211, Fax. +359 2 68 9102

Canada: PHILIPS SEMICONDUCTORS/COMPONENTS,
Tel. +1 800 234 7381, Fax. +1 800 943 0087

China/Hong Kong: 501 Hong Kong Industrial Technology Centre,
72 Tat Chee Avenue, Kowloon Tong, HONG KONG,
Tel. +852 2319 7888, Fax. +852 2319 7700

Colombia: see South America

Czech Republic: see Austria

Denmark: Sydhavnsgade 23, 1780 COPENHAGEN V,
Tel. +45 33 29 3333, Fax. +45 33 29 3905

Finland: Sinikalliontie 3, FIN-02630 ESPOO,
Tel. +358 9 615 800, Fax. +358 9 6158 0920

France: 51 Rue Carnot, BP317, 92156 SURESNES Cedex,
Tel. +33 1 4099 6161, Fax. +33 1 4099 6427

Germany: Hammerbrookstraße 69, D-20097 HAMBURG,
Tel. +49 40 2353 60, Fax. +49 40 2353 6300

Hungary: see Austria

India: Philips INDIA Ltd, Band Box Building, 2nd floor,
254-D, Dr. Annie Besant Road, Worli, MUMBAI 400 025,
Tel. +91 22 493 8541, Fax. +91 22 493 0966

Indonesia: PT Philips Development Corporation, Semiconductors Division,
Gedung Philips, Jl. Buncit Raya Kav.99-100, JAKARTA 12510,
Tel. +62 21 794 0040 ext. 2501, Fax. +62 21 794 0080

Ireland: Newstead, Clonskeagh, DUBLIN 14,
Tel. +353 1 7640 000, Fax. +353 1 7640 200

Israel: RAPAC Electronics, 7 Kehilat Saloniki St, PO Box 18053,
TEL AVIV 61180, Tel. +972 3 645 0444, Fax. +972 3 649 1007

Italy: PHILIPS SEMICONDUCTORS, Via Casati, 23 - 20052 MONZA (MI),
Tel. +39 039 203 6838, Fax +39 039 203 6800

Japan: Philips Bldg 13-37, Kohnan 2-chome, Minato-ku,
TOKYO 108-8507, Tel. +81 3 3740 5130, Fax. +81 3 3740 5057

Korea: Philips House, 260-199 Itaewon-dong, Yongsan-ku, SEOUL,
Tel. +82 2 709 1412, Fax. +82 2 709 1415

Malaysia: No. 76 Jalan Universiti, 46200 PETALING JAYA, SELANGOR,
Tel. +60 3 750 5214, Fax. +60 3 757 4880

Mexico: 5900 Gateway East, Suite 200, EL PASO, TEXAS 79905,
Tel. +9-5 800 234 7381, Fax +9-5 800 943 0087

Middle East: see Italy

Netherlands: Postbus 90050, 5600 PB EINDHOVEN, Bldg. VB,
Tel. +31 40 27 82785, Fax. +31 40 27 88399

New Zealand: 2 Wagener Place, C.P.O. Box 1041, AUCKLAND,
Tel. +64 9 849 4160, Fax. +64 9 849 7811

Norway: Box 1, Manglerud 0612, OSLO,
Tel. +47 22 74 8000, Fax. +47 22 74 8341

Pakistan: see Singapore

Philippines: Philips Semiconductors Philippines Inc.,
106 Valero St. Salcedo Village, P.O. Box 2108 MCC, MAKATI,
Metro MANILA, Tel. +63 2 816 6380, Fax. +63 2 817 3474

Poland: Ul. Lukiska 10, PL 04-123 WARSZAWA,
Tel. +48 22 612 2831, Fax. +48 22 612 2327

Portugal: see Spain

Romania: see Italy

Russia: Philips Russia, Ul. Usatcheva 35A, 119048 MOSCOW,
Tel. +7 095 755 6918, Fax. +7 095 755 6919

Singapore: Lorong 1, Toa Payoh, SINGAPORE 319762,
Tel. +65 350 2538, Fax. +65 251 6500

Slovakia: see Austria

Slovenia: see Italy

South Africa: S.A. PHILIPS Pty Ltd., 195-215 Main Road Martindale,
2092 JOHANNESBURG, P.O. Box 58088 Newville 2114,
Tel. +27 11 471 5401, Fax. +27 11 471 5398

South America: Al. Vicente Pinzon, 173, 6th floor,
04547-130 SÃO PAULO, SP, Brazil,
Tel. +55 11 821 2333, Fax. +55 11 821 2382

Spain: Balmes 22, 08007 BARCELONA,
Tel. +34 93 301 6312, Fax. +34 93 301 4107

Sweden: Kottbygatan 7, Akalla, S-16485 STOCKHOLM,
Tel. +46 8 5985 2000, Fax. +46 8 5985 2745

Switzerland: Allmendstrasse 140, CH-8027 ZÜRICH,
Tel. +41 1 488 2741 Fax. +41 1 488 3263

Taiwan: Philips Semiconductors, 6F, No. 96, Chien Kuo N. Rd., Sec. 1,
TAIPEI, Taiwan Tel. +886 2 2134 2886, Fax. +886 2 2134 2874

Thailand: PHILIPS ELECTRONICS (THAILAND) Ltd.,
209/2 Sanpavuth-Bangna Road Prakanong, BANGKOK 10260,
Tel. +66 2 745 4090, Fax. +66 2 398 0793

Turkey: Yukari Dudullu, Org. San. Blg., 2.Cad. Nr. 28 81260 Umraniye,
ISTANBUL, Tel. +90 216 522 1500, Fax. +90 216 522 1813

Ukraine: PHILIPS UKRAINE, 4 Patrice Lumumba str., Building B, Floor 7,
252042 KIEV, Tel. +380 44 264 2776, Fax. +380 44 268 0461

United Kingdom: Philips Semiconductors Ltd., 276 Bath Road, Hayes,
MIDDLESEX UB3 5BX, Tel. +44 208 730 5000, Fax. +44 208 754 8421

United States: 811 East Arques Avenue, SUNNYVALE, CA 94088-3409,
Tel. +1 800 234 7381, Fax. +1 800 943 0087

Uruguay: see South America

Vietnam: see Singapore

Yugoslavia: PHILIPS, Trg N. Pasicca 5/v, 11000 BEOGRAD,
Tel. +381 11 62 5344, Fax.+381 11 63 5777

For all other countries apply to: Philips Semiconductors,
International Marketing & Sales Communications, Building BE-p, P.O. Box 218,
5600 MD EINDHOVEN, The Netherlands, Fax. +31 40 27 24825

Internet: <http://www.semiconductors.philips.com>

© Philips Electronics N.V. 1999

SCA67

All rights are reserved. Reproduction in whole or in part is prohibited without the prior written consent of the copyright owner.

The information presented in this document does not form part of any quotation or contract, is believed to be accurate and reliable and may be changed without notice. No liability will be accepted by the publisher for any consequence of its use. Publication thereof does not convey nor imply any license under patent- or other industrial or intellectual property rights.

Printed in The Netherlands

545002/03/pp20

Date of release: 1999 Aug 19

Document order number: 9397 750 06271

Let's make things better.

Philips
Semiconductors



PHILIPS