

LOW CAPACITANCE TVS ARRAY

APPLICATIONS

- ✓ T1/E1 Line Cards
- ✓ ISDN U-Interfaces & ISDN S/T Interfaces
- ✓ xDSL Interfaces
- ✓ Ethernet - 10/100/1000 Base T
- ✓ Set-Top Box

IEC COMPATIBILITY (EN61000-4)

- ✓ 61000-4-2 (ESD): Air - 15kV, Contact - 8kV
- ✓ 61000-4-4 (EFT): 40A - 5/50ns
- ✓ 61000-4-5 (Surge): 8/20 μ s - 94A, L4(Line-Gnd), 48A, L1(Power) & 48A, L4(Line-Line)

FEATURES

- ✓ 100A (2/10 μ s) per Bellcore GR1089(Intra-Building)
- ✓ ESD Protection > 40 kilovolts
- ✓ 1800 Watts Peak Pulse Power per Line (tp = 8/20 μ s)
- ✓ **LOW CAPACITANCE: 8pF Typical**
- ✓ Telecom/Diode Bridge
- ✓ RoHS Compliant on Lead Free Versions

MECHANICAL CHARACTERISTICS

- ✓ Molded JEDEC SO-8
- ✓ Available in Tin-Lead or Lead-Free Pure-Tin Plating(Annealed)
- ✓ Solder Reflow Temperature:
 - Tin-Lead - Sn/Pb, 85/15: 240-245°C
 - Pure-Tin - Sn, 100: 260-270°C
- ✓ Weight 70mg(Approximate)
- ✓ Flammability Rating UL 94V-0
- ✓ 12mm Tape and Reel Per EIA Standard 481
- ✓ Marking: Marking Code, Logo, Date Code & Pin One Defined By Dot on Top of Package



PIN CONFIGURATION

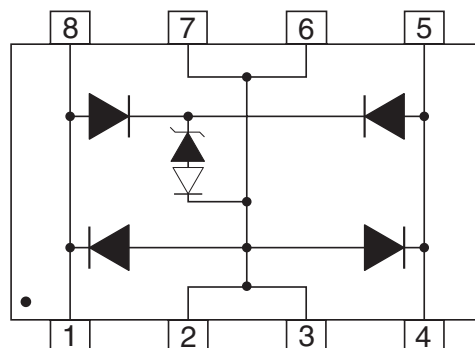

DEVICE CHARACTERISTICS

MAXIMUM RATINGS @ 25°C Unless Otherwise Specified			
PARAMETER	SYMBOL	VALUE	UNITS
Peak Pulse Power ($t_p = 8/20\mu s$) - See Figure 1	P_{PP}	1800	Watts
Operating Temperature	T_J	-55°C to 150°C	°C
Storage Temperature	T_{STG}	-55°C to 150°C	°C

ELECTRICAL CHARACTERISTICS PER LINE @ 25°C Unless Otherwise Specified							
PART NUMBER	DEVICE MARKING CODE	RATED STAND-OFF VOLTAGE	MINIMUM SNAP-BACK VOLTAGE	MAXIMUM CLAMPING VOLTAGE (Note 1 & 2) (See Fig. 2)	MAXIMUM LEAKAGE CURRENT	MAXIMUM CAPACITANCE (See Note 3)	MAXIMUM CAPACITANCE (See Note 4)
		V_{WM} VOLTS	@ 50mA $V_{(BR)}$ VOLTS	@ 8/20 μs $V_C @ I_{PP}$	@ V_{WM} I_D μA	@ 0V, 1 MHz C pF	@ 0V, 1 MHz C pF
PLC03-3.3	PBC	3.0	2.8	18.0V @ 100.0A	2.0	25	12

<p>MAXIMUM CLAMPING VOLTAGE Line-Ground 8/20μs @ $I_p = 50A$ V_C VOLTS</p>
11

Note 1: For an 8/20 μs waveform, apply positive pulse to pin 1 or 8 to pin 2 or 3(ground).

Note 2: Measured between pin 1 or 8 to pin 2 or 3.

Note 3: Measured between I/O pins and ground (pin 1 to 2).

Note 4: Measured between I/O pins (pins 1 to 4).

GRAPHS

**FIGURE 1
PEAK PULSE POWER VS PULSE TIME**

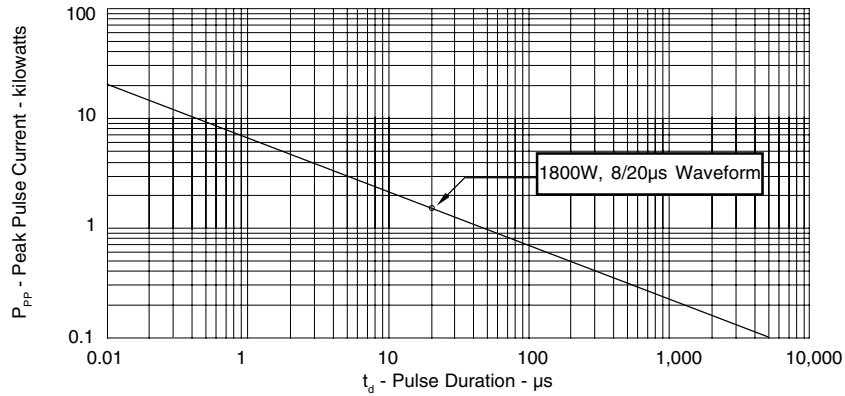

**FIGURE 2
PULSE WAVE FORM**

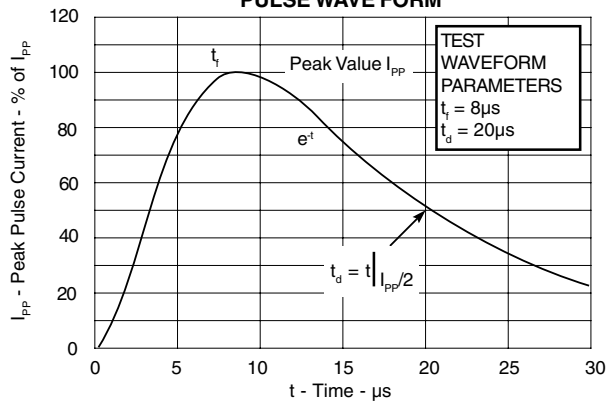

**FIGURE 3
POWER DERATING CURVE**

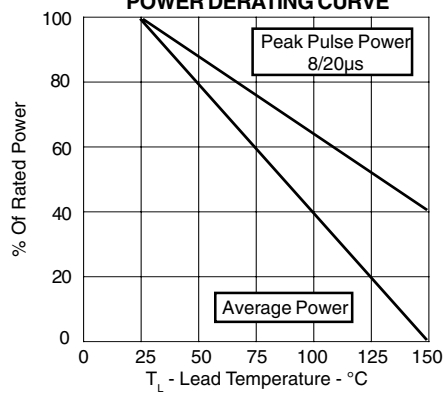

PACKAGE OUTLINE & DIMENSIONS

PACKAGE OUTLINE

$\oplus 0.010'' (0.25 \text{ MM}) \text{ (M) B (M)}$
 4 PL

$\oplus 0.010'' (0.25 \text{ MM}) \text{ (M) T B (S) A (S)}$
 8 PL

SO-8

PACKAGE DIMENSIONS

DIM	MILLIMETERS		INCHES	
	MIN	MAX	MIN	MAX
A	4.80	5.00	0.189	0.196
B	3.80	4.00	0.150	0.157
C	1.35	1.75	0.054	0.068
D	0.35	0.49	0.014	0.019
F	0.40	1.250	0.016	0.049
G	1.27 BSC	1.27 BSC	0.05 BSC	0.05 BSC
J	0.18	0.25	0.007	0.009
K	0.10	0.25	0.004	0.008
P	5.80	6.20	0.229	0.244
R	0.25	0.50	0.010	0.019

NOTES

- T - = Seating Plane and Datum Surface.
- Dimensions "A" and "B" are Datum.
- Dimensions "A" and "B" do not include mold protrusion.
- Maximum mold protrusion is 0.015" (0.380 mm) per side.
- Dimensioning and tolerances per ANSI Y14.5M, 1982.
- Dimensions are exclusive of mold flash and metal burrs.

TAPING & REEL/BULK ORDERING NOMENCLATURE

- Surface mount product is taped and reeled in accordance with EIA-481.
- Suffix-T7 = 7 Inch Reel - 1,000 pieces per 12mm tape, i.e., *PLC03-3.3-T7*.
- Suffix-T13 = 13 Inch Reel - 2,500 pieces per 12mm tape, i.e., *PLC03-3.3-T13*.
- Suffix-LF = Lead-Free, Pure Tin Plating, i.e., *PLC03-3.3-LF-T13*.
- No Suffix = Product Shipped in Tubes of 98 pcs per Tube.

Outline & Dimensions: Rev 1 - 11/01, 06009

MOUNTING PAD

$0.050 \pm 0.005''$
 $0.030 \pm 0.005''$
 $0.160 \pm 0.005''$
 $0.245'' \text{ MIN}$
 $0.045 \pm 0.005''$

COPYRIGHT © ProTek Devices 2005

SPECIFICATIONS: ProTek reserves the right to change the electrical and or mechanical characteristics described herein without notice (except JEDEC).

DESIGN CHANGES: ProTek reserves the right to discontinue product lines without notice, and that the final judgement concerning selection and specifications is the buyer's and that in furnishing engineering and technical assistance, ProTek assumes no responsibility with respect to the selection or specifications of such products.

ProTek Devices
 2929 South Fair Lane, Tempe, AZ 85282
 Tel: 602-431-8101 Fax: 602-431-2288
 E-Mail: sales@protekdevices.com
 Web Site: www.protekdevices.com