

**PLEASE CHECK WWW.MOLEX.COM FOR LATEST PART INFORMATION**

**Part Number:** [0873690800](#)  
**Status:** **Active**  
**Description:** 2.00mm (.079") Pitch Crimp Housing, Single Row, 8 Circuits

**Documents:**

[3D Model](#) [RoHS Certificate of Compliance \(PDF\)](#)  
[Drawing \(PDF\)](#)

**Agency Certification**

CSA LR19980  
 UL E29179

**General**

Product Family Crimp Housings  
 Series [87369](#)  
 Product Name N/A

**Physical**

Circuits (maximum) 8  
 Color - Resin Natural  
 Flammability 94V-0  
 Gender Female  
 Glow-Wire Compliant No  
 Lock to Mating Part Yes  
 Material - Resin Nylon  
 Number of Rows 1  
 Packaging Type Bag  
 Panel Mount No  
 Pitch - Mating Interface (in) 0.079 In  
 Pitch - Mating Interface (mm) 2.00 mm  
 Stackable No  
 Temperature Range - Operating -25°C to +85°C

**Material Info**

**Reference - Drawing Numbers**

Product Specification RPS-87369-001  
 Sales Drawing SD-87369-\*\*0\*

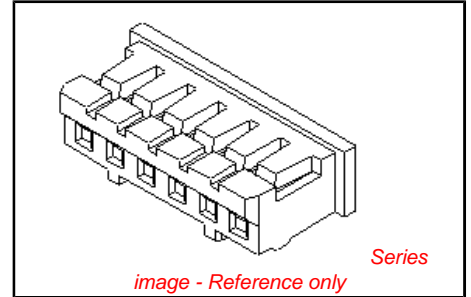

**EU RoHS**

**ELV and RoHS Compliant**  
**REACH SVHC Contains SVHC: No**  
**Halogen-Free Status**  
**Not Halogen-Free**

**China RoHS**



**Need more information on product environmental compliance?**

Email [productcompliance@molex.com](mailto:productcompliance@molex.com)  
 For a multiple part number RoHS Certificate of Compliance, [click here](#)

Please visit the [Contact Us](#) section for any non-product compliance questions.

**Search Parts in this Series**

[87369Series](#)

**Mates With**

[89400](#) Vertical Header, [89401](#) Right Angle Header

**Use With**

[50212](#) Crimp Terminals. [104440](#) 2.00mm (.079") Pitch Crimp Terminals

**PLEASE CHECK WWW.MOLEX.COM FOR LATEST PART INFORMATION**

DWG. NO. SD 87369-\*\*-00  
 CAD FILE S87369.DGN

8 7 6 5 4 3 2 1

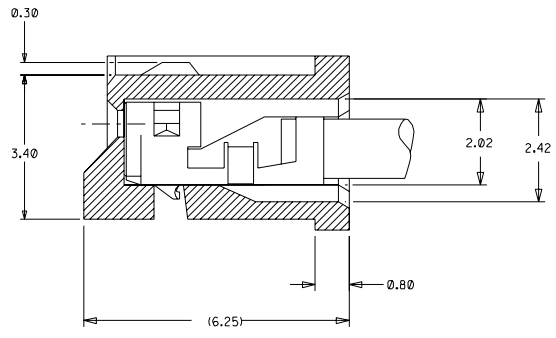
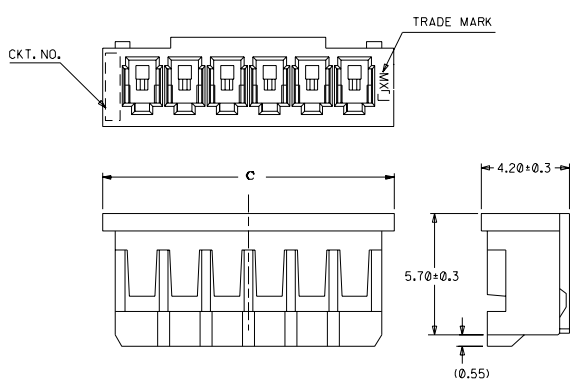

**TERMINAL ASSEMBLY DRAWING**  
(10:1)

**PART NO. LEGEND**

87369 - \*\* 0 .  
 CKT SIZE      COLOR OPTION  
 0 - NATURAL  
 1 - BLACK  
 2 - RED  
 3 - YELLOW  
 4 - BLUE  
 5 - GREEN

**NOTES**

1. APPLICABLE TERMINAL :50212-8\*00
2. MATERIAL : NYLON 66, UL94V-0 NATURAL
3. MATES WITH 89400-\*\*-10/\*\*20 & 89401-\*\*-10

33.74	32.54	30	87369-160*	16
31.74	30.54	28	87369-150*	15
29.74	28.54	26	87369-140*	14
27.74	26.54	24	87369-130*	13
25.74	24.54	22	87369-120*	12
23.74	22.54	20	87369-110*	11
21.74	20.54	18	87369-100*	10
19.74	18.54	16	87369-090*	9
17.74	16.54	14	87369-080*	8
15.74	14.54	12	87369-070*	7
13.74	12.54	10	87369-060*	6
11.74	10.54	8	87369-050*	5
9.74	8.54	6	87369-040*	4
7.74	6.54	4	87369-030*	3
5.74	4.54	2	87369-020*	2

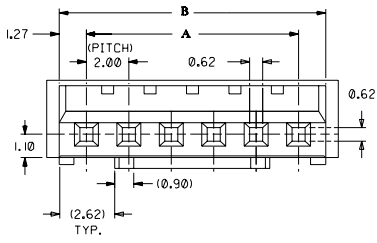

**IN CASE OF  
2 CIRCUIT HSG.**

**IN CASE OF  
3 CIRCUIT HSG.**

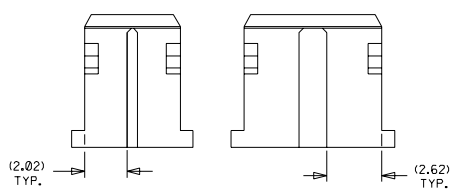

**UNITS : MM**

MATERIAL : SEE NOTES		MOLEX SINGAPORE PTE LTD SHEET 1 OF 1																									
FINISH : ---		GENERAL TOLERANCES : ± 0.20/0.08 REV B5																									
DRAWN BY CLEE 920305 CHK'D BY JOEY 920326		TITLE : 2.0 MM PITCH WIRE TO BOARD CONN. RECEPTACLE																									
APPR'D BY ROY 920326 SCALE 5:1																											
<table border="1"> <tr> <th>LTR</th> <th>REVISION RECORD</th> <th>ECN</th> <th>DR</th> <th>CHK</th> <th>DATE</th> </tr> <tr> <td>B5</td> <td>REVISE PART NO. LEGEND &amp; NOTE 3 PER ECN 1999-0061</td> <td>-</td> <td>SAX</td> <td></td> <td>980814</td> </tr> <tr> <td>B4</td> <td>REL 87369-**-05 (GREEN) AS PER PDR# 98-06-0330 (AS PER ECN# S1998-0617)</td> <td>-</td> <td>SEE TOH</td> <td></td> <td>980623</td> </tr> <tr> <td>B3</td> <td>ADD COLOR OPTION REPLACE SD-87369-**-0*</td> <td>S60565</td> <td>SAX</td> <td>GMR</td> <td>960618</td> </tr> </table>				LTR	REVISION RECORD	ECN	DR	CHK	DATE	B5	REVISE PART NO. LEGEND & NOTE 3 PER ECN 1999-0061	-	SAX		980814	B4	REL 87369-**-05 (GREEN) AS PER PDR# 98-06-0330 (AS PER ECN# S1998-0617)	-	SEE TOH		980623	B3	ADD COLOR OPTION REPLACE SD-87369-**-0*	S60565	SAX	GMR	960618
LTR	REVISION RECORD	ECN	DR	CHK	DATE																						
B5	REVISE PART NO. LEGEND & NOTE 3 PER ECN 1999-0061	-	SAX		980814																						
B4	REL 87369-**-05 (GREEN) AS PER PDR# 98-06-0330 (AS PER ECN# S1998-0617)	-	SEE TOH		980623																						
B3	ADD COLOR OPTION REPLACE SD-87369-**-0*	S60565	SAX	GMR	960618																						
<table border="1"> <tr> <th>REV</th> <th>DESCRIPTION</th> <th>DATE</th> </tr> <tr> <td>1</td> <td>REVISED</td> <td>980814</td> </tr> </table>				REV	DESCRIPTION	DATE	1	REVISED	980814																		
REV	DESCRIPTION	DATE																									
1	REVISED	980814																									
<p><b>REVISE ONLY ON CAD SYSTEM</b></p>																											

THIS DRAWING CONTAINS INFORMATION THAT IS PROPRIETARY TO MOLEX (S) PTE LTD AND SHOULD NOT BE USED WITHOUT WRITTEN PERMISSION

DO NOT SCALE DRAWING