

ST-1MLAR2. ST-1MLBR2

The ST-1MLAR2 and 1MLBR2 is a high sensitivity NPN silicon phototransistor mounted in a TO-18 Type header with black epoxy encapsulation. With daylight filter the phototransistor is sensitive only to infrared rays.

Features

- Wide angular response
- Relatively low-cost against metal can package
- Low profile package
- With daylight filter

Applications

- Remote control sensors
- Card readers
- Optical switches

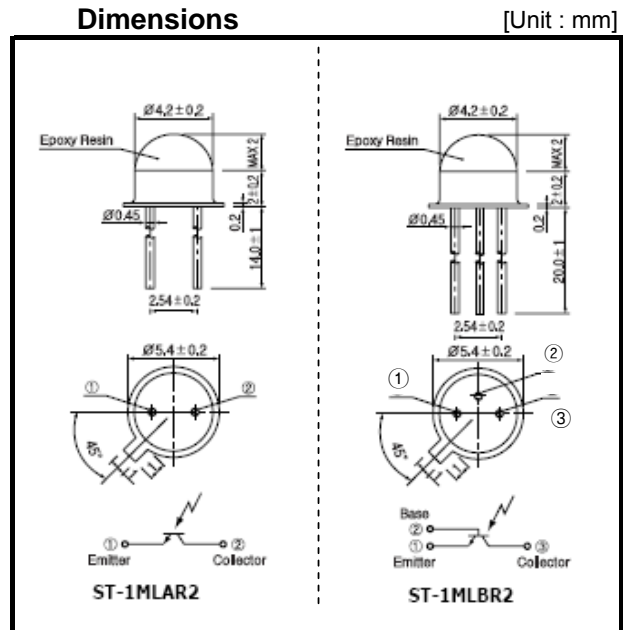

Absolute Maximum Ratings

[T_A = 25°C]

Parameter	Symbol	Rating	Unit
C-E Voltage	V _{CEO}	40	V
E-C Voltage	V _{ECO}	4	V
Collector current	I _C	30	mA
Collector power dissipation	P _C	100	mW
Operating temp	T _{opr.}	-25~+90	°C
Storage temp	T _{stg.}	-30~+100	°C
Soldering temp ^{*1}	T _{sol}	260	°C

*1. For MAX.5 seconds at the position of 2mm from the package

Electro-Optical Characteristics

[T_A = 25°C]

Parameter	Symbol	Conditions	Min.	Typ.	Max.	Unit.
Collector dark current	I _{CEO}	V _{CEO} =10V	-	1	200	nA
Light current	I _L	V _{CE} =10V, 200lx ^{*2}	0.5	1.2	5.0	mA
C-E saturation voltage	V _{CE(sat)}	I _C =2mA, 2,000lx ^{*2}	-	0.2	0.4	V
Switching speeds	Rise time	V _{CC} =10V, I _C =5mA R _L =100Ω	-	8	-	μsec
	Fall time		-	10	-	μsec
Spectral sensitivity	λ		720 ~ 1,050			nm
Peak wavelength	λ _p		-	940	-	nm
Half Angle	Δθ		-	±70	-	degrees

*2. Color temp = 2856K standard tungsten lamp

ST-1MLAR2. ST-1MLBR2

