

## 2-line IPAD™, EMI filter and ESD protection

### Features

- EMI symmetrical (I/O) low-pass filter
- High efficiency in EMI filtering
- Very low PCB space consuming:  
1.07 mm x 1.47 mm
- Very thin package: 0.65 mm
- High efficiency in ESD suppression
- High reliability offered by monolithic integration
- High reducing of parasitic elements through integration and wafer level packaging

### Complies with the following standards:

- IEC 61000-4-2 level 4, on output pins:
  - 15 kV (air discharge)
  - 8 kV (contact discharge)
- IEC 61000-4-2 Level 1, on input pins:
  - 2 kV (air discharge)
  - 2 kV (contact discharge)
- MIL STD 883E - Method 3015-6 Class 3

### Applications

Where EMI filtering in ESD sensitive equipment is required:

- Mobile phones and communication systems
- Computers, printers and MCU Boards

### Description

The EMIF02-SPK01 is a highly integrated device designed to suppress EMI/RFI noise in all systems subjected to electromagnetic interferences. The EMIF02 Flip-Chip packaging means the package size is equal to the die size.

This filter includes an ESD protection circuitry which prevents damage to the application when subjected to ESD surges up to 15 kV.

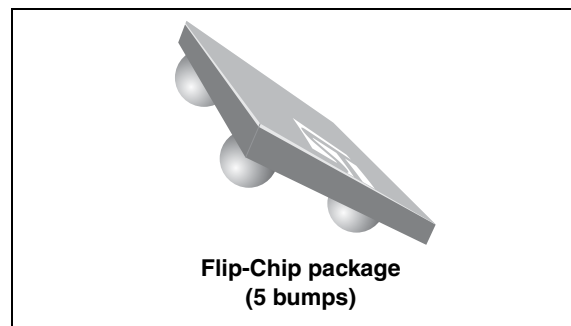

**Figure 1. Pin configuration (bump side)**

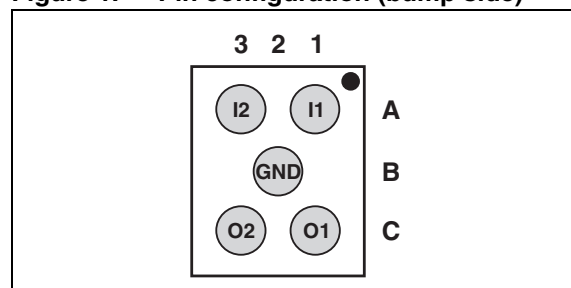

**Figure 2. Basic cell configuration**

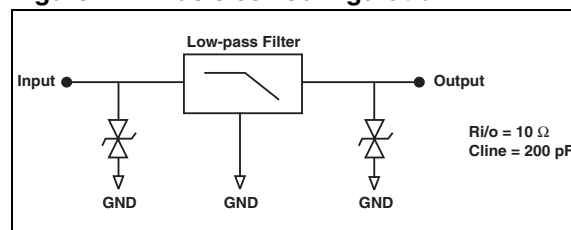

**TM:** IPAD is a trademark of STMicroelectronics.

# 1 Electrical characteristics

**Table 1. Absolute maximum ratings ( $T_{amb} = 25\text{ }^{\circ}\text{C}$ )**

Symbol	Parameter	Value	Unit
$T_j$	Maximum junction temperature	125	$^{\circ}\text{C}$
$T_{op}$	Operating temperature range	-40 to +85	$^{\circ}\text{C}$
$T_{stg}$	Storage temperature range	-55 to +150	$^{\circ}\text{C}$

**Figure 3. Electrical characteristics (definitions)**

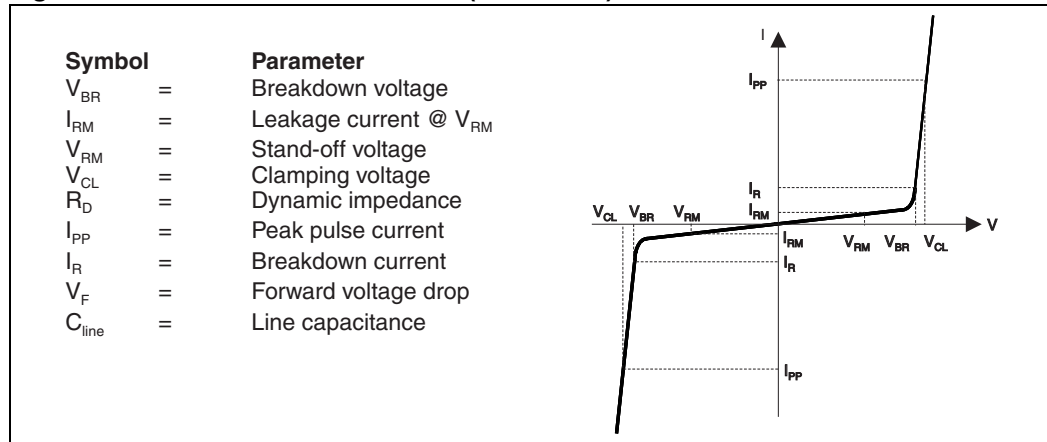

**Table 2. Electrical characteristics ( $T_{amb} = 25\text{ }^{\circ}\text{C}$ )**

Symbol	Test condition	Min.	Typ.	Max.	Unit
$V_{BR}$	$I_R = 1\text{ mA}$	6	8		V
$I_{RM}$	$V_{RM} = 3\text{ V per line}$			500	nA
$R_{I/O}$	Tolerance $\pm 20\%$		10		$\Omega$
$C_{line}$	$V_R = 0\text{ V}$		200		pF

Figure 4. S21 (dB) attenuation measurements Figure 5. Analog crosstalk measurements and Aplac simulation

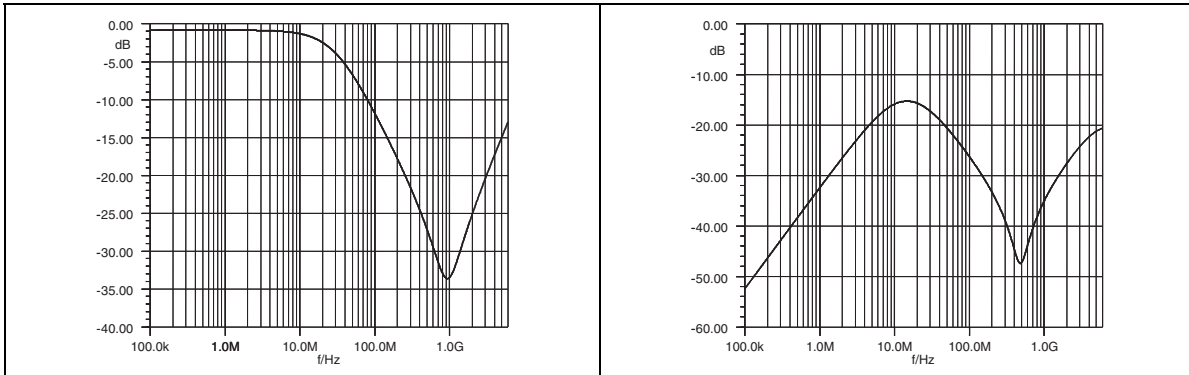

Figure 6. ESD response to IEC 61000-4-2 (+15kV air discharge) on one input  $V_{(in)}$  and one output  $V_{(out)}$  Figure 7. ESD response to IEC 61000-4-2 (-15kV air discharge) on one input  $V_{(in)}$  and one output  $V_{(out)}$

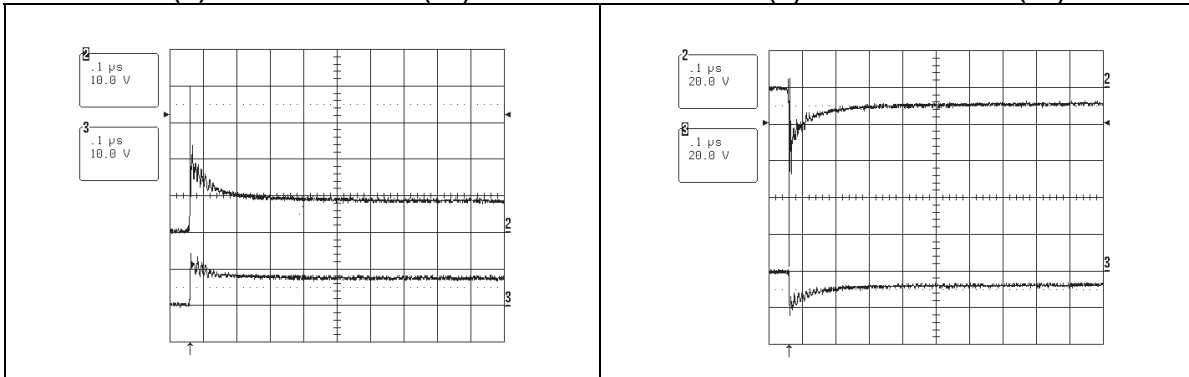

Figure 8. Line capacitance versus applied voltage

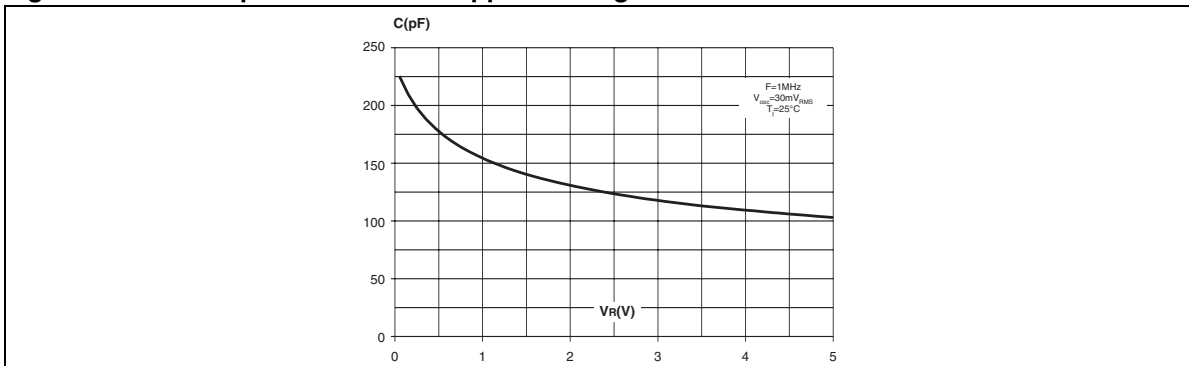

Figure 9. Aplac mode

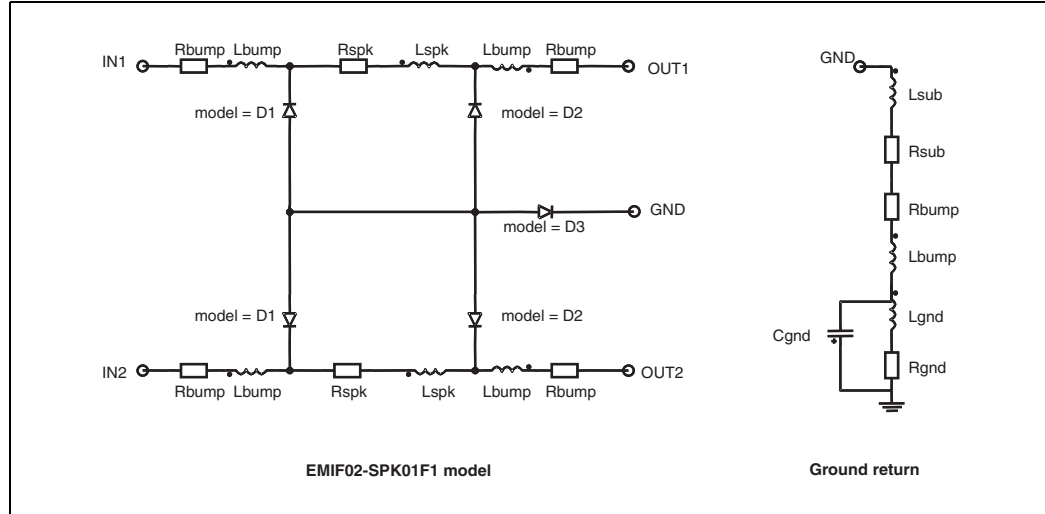
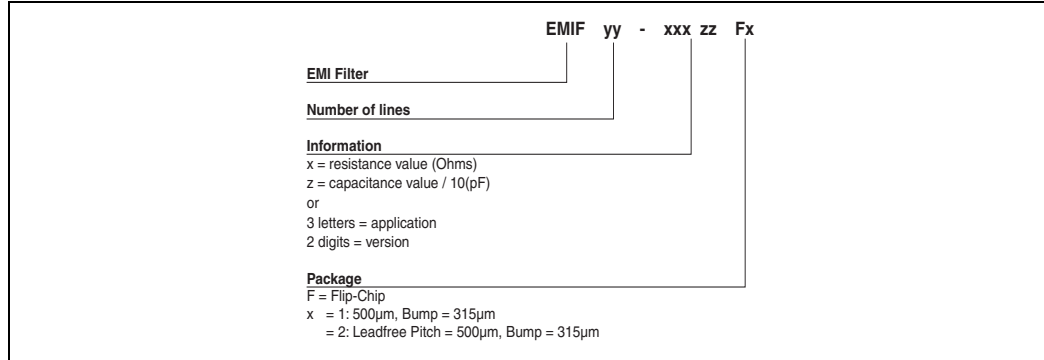

Figure 10. Aplac parameters

Model D1	Model D3	Model D2	aplacvar Ls 1nH
CJO=Cdiode1	CJO=Cdiode3	CJO=Cdiode2	aplacvar Rs 150m
BV=7	BV=7	BV=7	aplacvar Rspk 10
IBV=1u	IBV=1u	IBV=1u	aplacvar Lspk 10p
IKF=1000	IKF=1000	IKF=1000	aplacvar Cdiode1 234pF
IS=10f	IS=10f	IS=10f	aplacvar Cdiode2 3.5ppF
ISR=100p	ISR=100p	ISR=100p	aplacvar Cdiode3 1nF
N=1	N=1	N=1	aplacvar Lbump 50pH
M=0.3333	M=0.3333	M=0.3333	aplacvar Rbump 10m
RS=0.7	RS=0.12	RS=0.3	aplacvar Rsub 0.5m
VJ=0.6	VJ=0.6	VJ=0.6	aplacvar Lsub 10pH
TT=50n	TT=50n	TT=50n	aplacvar Rgnd 1m
			aplacvar Lgnd 50pH
			aplacvar Cgnd 0.15pF

## 2 Ordering information

Figure 11. Ordering information scheme



## 3 Packaging information

In order to meet environmental requirements, ST offers these devices in different grades of ECOPACK® packages, depending on their level of environmental compliance. ECOPACK® specifications, grade definitions and product status are available at: [www.st.com](http://www.st.com). ECOPACK® is an ST trademark.

Figure 12. Flip-Chip dimensions

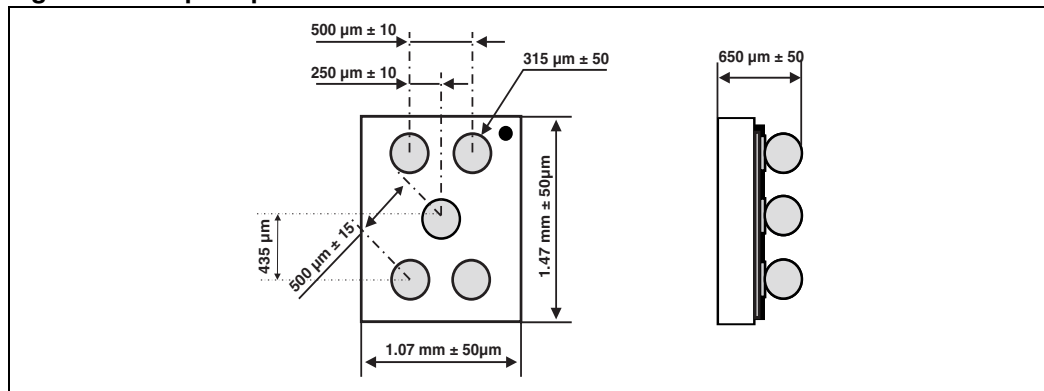

Figure 13. Footprint

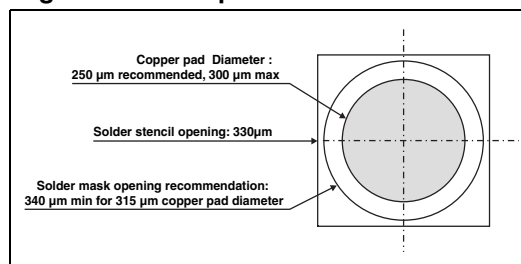

Figure 14. Marking

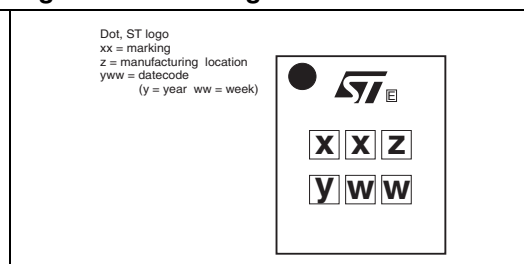
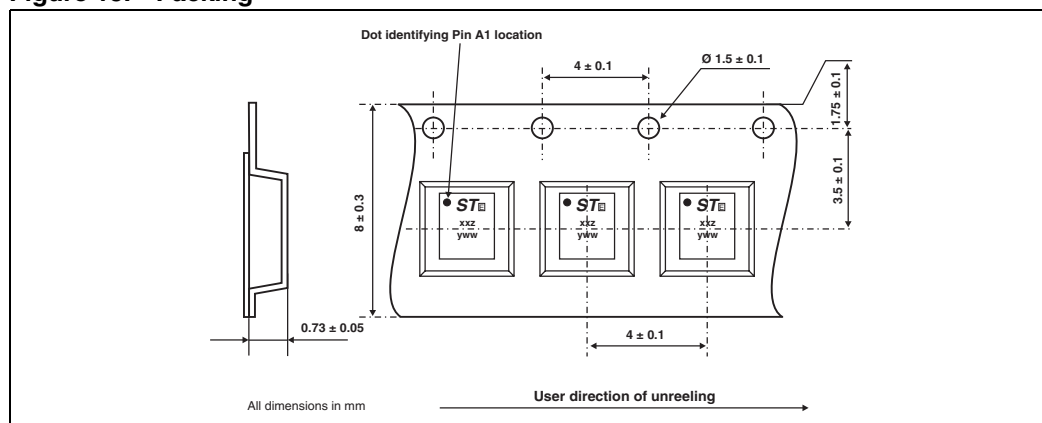

Figure 15. Packing



## 4 Ordering information

Table 3. Ordering information

Order code	Marking	Package	Weight	Base qty	Delivery mode
EMIF02-SPK01F2	FX	Flip Chip	2.1 mg	5000	Tape and reel (7")

Note: More packing information is available in the applications note:  
 AN1235: "Flip-Chip: package description and recommendations for use"  
 AN 1751: "EMI filters: Recommendations and measurements"

## 5 Revision history

Table 4. Document revision history

Date	Revision	Changes
14-Oct-2006	1	Initial release.
08-Sep-2011	2	Updated <a href="#">Figure 12</a> and <a href="#">Figure 13</a> .

**Please Read Carefully:**

Information in this document is provided solely in connection with ST products. STMicroelectronics NV and its subsidiaries ("ST") reserve the right to make changes, corrections, modifications or improvements, to this document, and the products and services described herein at any time, without notice.

All ST products are sold pursuant to ST's terms and conditions of sale.

Purchasers are solely responsible for the choice, selection and use of the ST products and services described herein, and ST assumes no liability whatsoever relating to the choice, selection or use of the ST products and services described herein.

No license, express or implied, by estoppel or otherwise, to any intellectual property rights is granted under this document. If any part of this document refers to any third party products or services it shall not be deemed a license grant by ST for the use of such third party products or services, or any intellectual property contained therein or considered as a warranty covering the use in any manner whatsoever of such third party products or services or any intellectual property contained therein.

**UNLESS OTHERWISE SET FORTH IN ST'S TERMS AND CONDITIONS OF SALE ST DISCLAIMS ANY EXPRESS OR IMPLIED WARRANTY WITH RESPECT TO THE USE AND/OR SALE OF ST PRODUCTS INCLUDING WITHOUT LIMITATION IMPLIED WARRANTIES OF MERCHANTABILITY, FITNESS FOR A PARTICULAR PURPOSE (AND THEIR EQUIVALENTS UNDER THE LAWS OF ANY JURISDICTION), OR INFRINGEMENT OF ANY PATENT, COPYRIGHT OR OTHER INTELLECTUAL PROPERTY RIGHT.**

**UNLESS EXPRESSLY APPROVED IN WRITING BY TWO AUTHORIZED ST REPRESENTATIVES, ST PRODUCTS ARE NOT RECOMMENDED, AUTHORIZED OR WARRANTED FOR USE IN MILITARY, AIR CRAFT, SPACE, LIFE SAVING, OR LIFE SUSTAINING APPLICATIONS, NOR IN PRODUCTS OR SYSTEMS WHERE FAILURE OR MALFUNCTION MAY RESULT IN PERSONAL INJURY, DEATH, OR SEVERE PROPERTY OR ENVIRONMENTAL DAMAGE. ST PRODUCTS WHICH ARE NOT SPECIFIED AS "AUTOMOTIVE GRADE" MAY ONLY BE USED IN AUTOMOTIVE APPLICATIONS AT USER'S OWN RISK.**

Resale of ST products with provisions different from the statements and/or technical features set forth in this document shall immediately void any warranty granted by ST for the ST product or service described herein and shall not create or extend in any manner whatsoever, any liability of ST.

ST and the ST logo are trademarks or registered trademarks of ST in various countries.

Information in this document supersedes and replaces all information previously supplied.

The ST logo is a registered trademark of STMicroelectronics. All other names are the property of their respective owners.

© 2011 STMicroelectronics - All rights reserved

STMicroelectronics group of companies

Australia - Belgium - Brazil - Canada - China - Czech Republic - Finland - France - Germany - Hong Kong - India - Israel - Italy - Japan - Malaysia - Malta - Morocco - Philippines - Singapore - Spain - Sweden - Switzerland - United Kingdom - United States of America

[www.st.com](http://www.st.com)