



WBFBP-08A Plastic-Encapsulate Transistors

FMQT4292 TRANSISTOR

DESCRIPTION

PNP and NPN Epitaxial Silicon Transistor

FEATURES

- Complementary Pair
- Tow A42-Type NPN, Tow A92-Type PNP
- Epitaxial Planar Die Construction

APPLICATION

IDEAL FOR LOW POWER AMPLIFICATION AND SWITCHING

For portable equipment:(i.e. Mobile phone,MP3, MD,CD-ROM, DVD-ROM, Note book PC, etc.)

WBFBP-08A

(4×4×0.5)
unit: mm

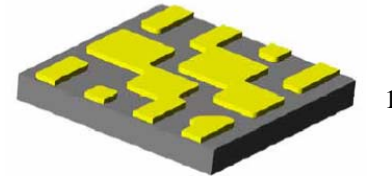

MARKING: 4292

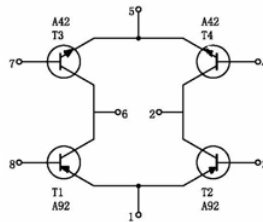
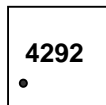

A42 MAXIMUM RATINGS* $T_A=25^{\circ}\text{C}$ unless otherwise noted

Symbol	Parameter	Value	Units
V_{CBO}	Collector-Base Voltage	310	V
V_{CEO}	Collector-Emitter Voltage	305	V
V_{EBO}	Emitter-Base Voltage	5	V
I_C	Collector Current -Continuous	500	mA
T_J, T_{stg}	Junction and Storage Temperature	-55-150	$^{\circ}\text{C}$
$R_{\theta JA}$	Thermal Resistance, junction to Ambient	200	$^{\circ}\text{C}/\text{mW}$
$R_{\theta JC}$	Thermal Resistance, unction to Case	83.3	$^{\circ}\text{C}/\text{mW}$

A92 MAXIMUM RATINGS* $T_A=25^{\circ}\text{C}$ unless otherwise noted

Symbol	Parameter	Value	Units
V_{CBO}	Collector-Base Voltage	-300	V
V_{CEO}	Collector-Emitter Voltage	-300	V
V_{EBO}	Emitter-Base Voltage	-5	V
I_C	Collector Current -Continuous	-500	mA
T_J, T_{stg}	Junction and Storage Temperature	-55-150	$^{\circ}\text{C}$
$R_{\theta JA}$	Thermal Resistance, junction to Ambient	200	$^{\circ}\text{C}/\text{mW}$
$R_{\theta JC}$	Thermal Resistance, unction to Case	83.3	$^{\circ}\text{C}/\text{mW}$

A42 ELECTRICAL CHARACTERISTICS (Tamb=25°C unless otherwise specified)

Parameter	Symbol	Test conditions	MIN	MAX	UNIT
Collector-base breakdown voltage	$V_{(BR)CBO}$	$I_C = 100\mu A, I_E = 0$	310		V
Collector-emitter breakdown voltage	$V_{(BR)CEO}$	$I_C = 1\text{ mA}, I_B = 0$	305		V
Emitter-base breakdown voltage	$V_{(BR)EBO}$	$I_E = 100\mu A, I_C = 0$	5		V
Collector cut-off current	I_{CBO}	$V_{CB} = 200V, I_E = 0$		0.25	μA
Emitter cut-off current	I_{EBO}	$V_{EB} = 5V, I_C = 0$		0.1	μA
DC current gain	$H_{FE(1)}$	$V_{CE} = 10V, I_C = 1mA$	60		
	$H_{FE(2)}$	$V_{CE} = 10V, I_C = 10mA$	100	200	
	$H_{FE(3)}$	$V_{CE} = 10V, I_C = 30mA$	60		
Collector-emitter saturation voltage	$V_{CE(sat)}$	$I_C = 20\text{ mA}, I_B = 2mA$		0.2	V
Base-emitter saturation voltage	$V_{BE(sat)}$	$I_C = 20\text{ mA}, I_B = 2mA$		0.9	V
Transition frequency	f_T	$V_{CE} = 20V, I_C = 10mA$ $f = 30MHz$	50		MHz

A92 ELECTRICAL CHARACTERISTICS (Tamb=25°C unless otherwise specified)

Parameter	Symbol	Test conditions	MIN	MAX	UNIT
Collector-base breakdown voltage	$V_{(BR)CBO}$	$I_C = -100\mu A, I_E = 0$	-300		V
Collector-emitter breakdown voltage	$V_{(BR)CEO}$	$I_C = -1mA, I_B = 0$	-300		V
Emitter-base breakdown voltage	$V_{(BR)EBO}$	$I_E = -100\mu A, I_C = 0$	-5		V
Collector cut-off current	I_{CBO}	$V_{CB} = -200V, I_E = 0$		-0.25	μA
Emitter cut-off current	I_{EBO}	$V_{EB} = -5V, I_C = 0$		-0.1	μA
DC current gain	$H_{FE(1)}$	$V_{CE} = -10V, I_C = -1mA$	60		
	$H_{FE(2)}$	$V_{CE} = -10V, I_C = -10mA$	100	200	
	$H_{FE(3)}$	$V_{CE} = -10V, I_C = -30mA$	60		
Collector-emitter saturation voltage	$V_{CE(sat)}$	$I_C = -20\text{ mA}, I_B = -2mA$		-0.2	V
Base-emitter saturation voltage	$V_{BE(sat)}$	$I_C = -20\text{ mA}, I_B = -2mA$		-0.9	V
Transition frequency	f_T	$V_{CE} = -20V, I_C = -10mA$ $f = 30MHz$	50		MHz

Typical Characteristics

A42

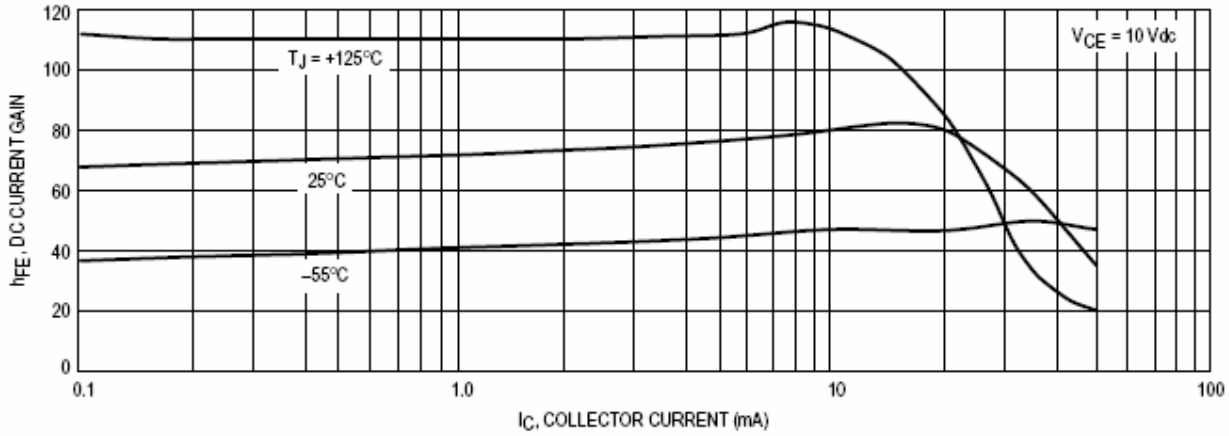

Figure 1. DC Current Gain

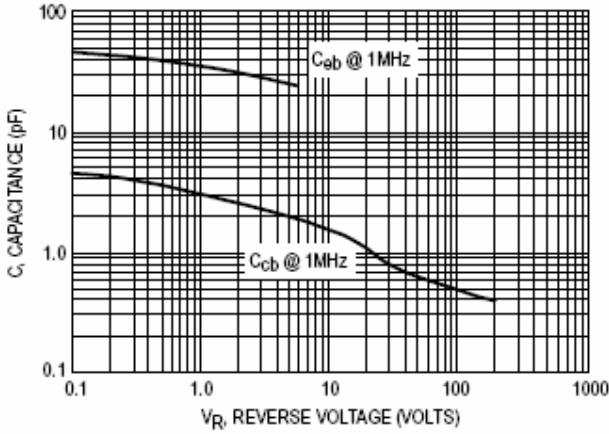

Figure 2. Capacitance

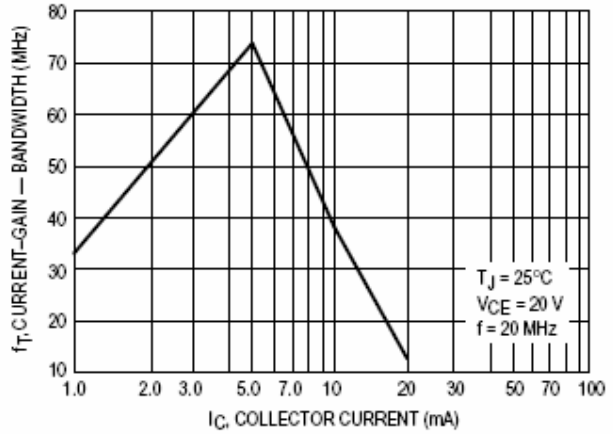

Figure 3. Current-Gain - Bandwidth

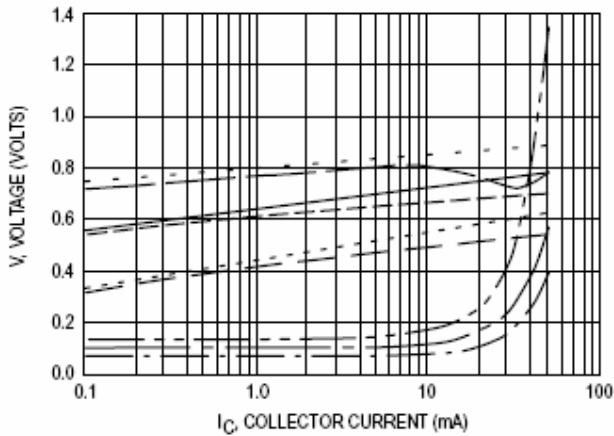

Figure 4. "ON" Voltages

- $V_{CE(sat)}$ @ 25°C , $I_C/I_B = 10$
- $V_{CE(sat)}$ @ 125°C , $I_C/I_B = 10$
- $V_{CE(sat)}$ @ -55°C , $I_C/I_B = 10$
- $V_{BE(sat)}$ @ 25°C , $I_C/I_B = 10$
- $V_{BE(sat)}$ @ 125°C , $I_C/I_B = 10$
- $V_{BE(sat)}$ @ -55°C , $I_C/I_B = 10$
- $V_{BE(on)}$ @ 25°C , $V_{CE} = 10\text{ V}$
- $V_{BE(on)}$ @ 125°C , $V_{CE} = 10\text{ V}$
- $V_{BE(on)}$ @ -55°C , $V_{CE} = 10\text{ V}$

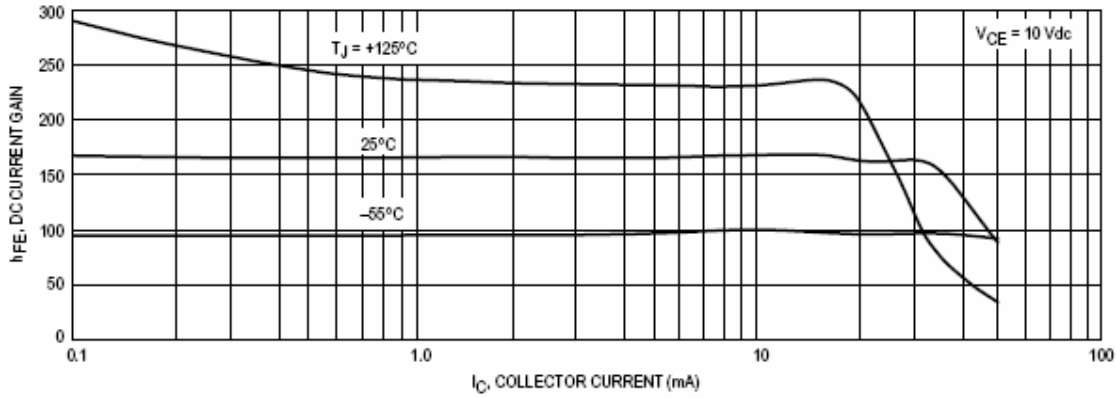

Figure 1. DC Current Gain

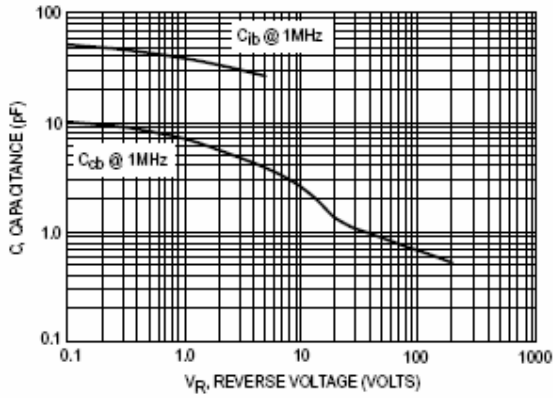

Figure 2. Capacitance

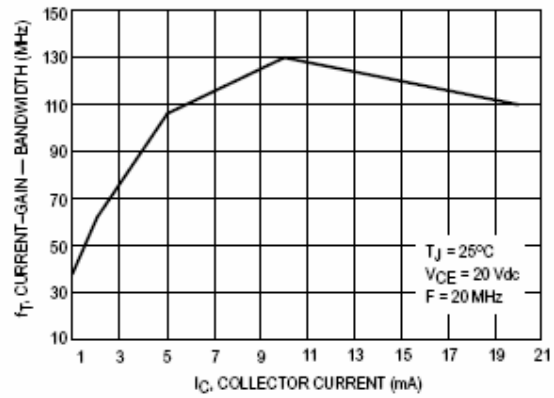

Figure 3. Current-Gain — Bandwidth

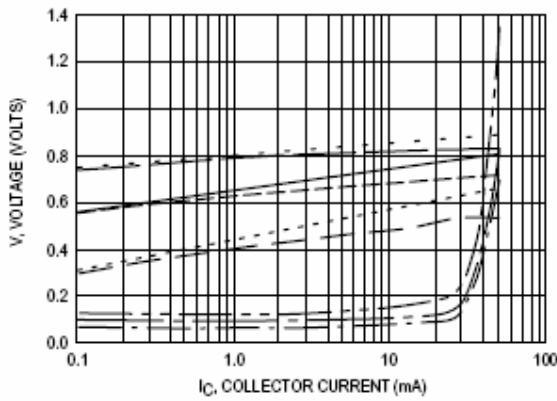
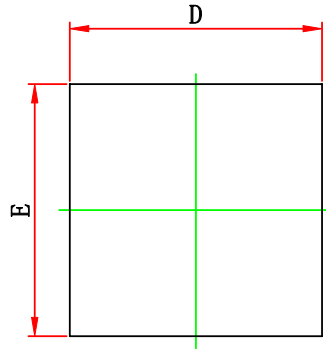

Figure 4. "ON" Voltages

- $V_{CE(sat)}$ @ 25°C , $I_C/I_B = 10$
- $V_{CE(sat)}$ @ 125°C , $I_C/I_B = 10$
- $V_{CE(sat)}$ @ -55°C , $I_C/I_B = 10$
- $V_{BE(sat)}$ @ 25°C , $I_C/I_B = 10$
- $V_{BE(sat)}$ @ 125°C , $I_C/I_B = 10$
- $V_{BE(sat)}$ @ -55°C , $I_C/I_B = 10$
- $V_{BE(on)}$ @ 25°C , $V_{CE} = 10 \text{ V}$
- $V_{BE(on)}$ @ 125°C , $V_{CE} = 10 \text{ V}$
- $V_{BE(on)}$ @ -55°C , $V_{CE} = 10 \text{ V}$



WBFBP-08A(4×4×0.5) PACKAGE OUTLINE DIMENSIONS



TOP VIEW

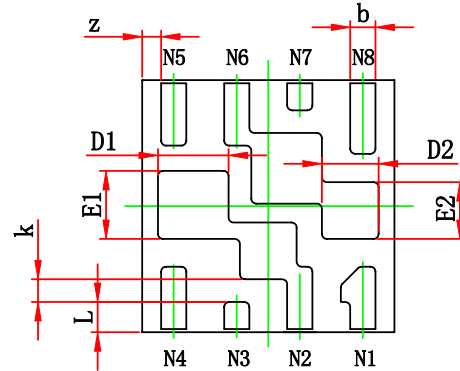

BOTTOM VIEW

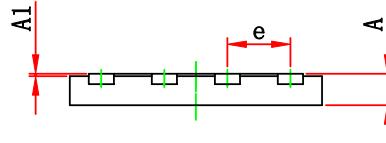

SIDE VIEW

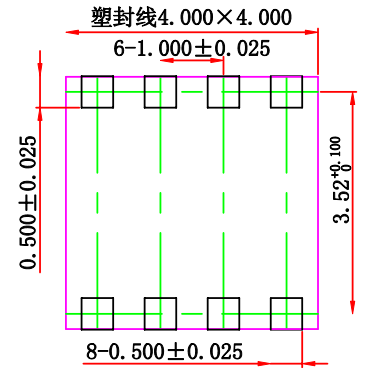

LAND PATTERN RECOMMENDATION
推荐焊盘图

Symbol	Dimensions In Millimeters		Dimensions In Inches	
	Min.	Max.	Min.	Max.
A	0.450	0.550	0.018	0.022
A1	0.000	0.100	0.000	0.004
b	0.350	0.450	0.014	0.018
D	3.900	4.100	0.154	0.161
E	3.900	4.100	0.154	0.161
D1	1.120 REF.		0.044 REF.	
E1	1.120 REF.		0.044 REF.	
D2	0.900 REF.		0.035 REF.	
E2	0.900 REF.		0.035 REF.	
e	1.000 TYP.		0.040 TYP.	
L	0.450 REF.		0.018 REF.	
k	0.300 REF.		0.012 REF.	
z	0.300 REF.		0.012 REF.	