

Product Description

Stanford Microdevices' SNA-276 is a GaAs monolithic broadband amplifier (MMIC) housed in a low-cost surface mountable stripline package. This amplifier provides 16dB of gain when biased at 50mA and 4V.

External DC decoupling capacitors determine low frequency response. The use of an external resistor allows for bias flexibility and stability.

These unconditionally stable amplifiers are designed for use as general purpose 50 ohm gain blocks. Also available in chip form (SNA-200), its small size (0.33mm x 0.33mm) and gold metallization, make it an ideal choice for use in hybrid circuits.

The SNA-276 is available in tape and reel at 1000, 3000 and 5000 devices per reel.

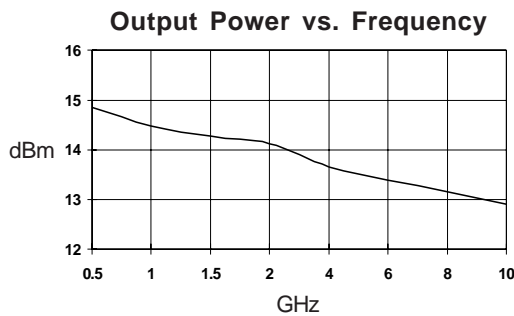

Electrical Specifications at Ta = 25° C

Symbol	Parameters: Test Conditions: Id = 50 mA, Z ₀ = 50 Ohms		Units	Min.	Typ.	Max.
G _P	Small Signal Power Gain	f = 0.1-2.0 GHz f = 2.0-4.0 GHz f = 4.0-6.5 GHz	dB dB dB	15.0 14.0 13.0	16.0 15.0 14.0	
G _F	Gain Flatness	f = 0.1-4.0 GHz	dB		+/-1.0	
BW _{3dB}	3dB Bandwidth		GHz		6.5	
P _{1dB}	Output Power at 1dB Compression	f = 2.0 GHz	dBm		14.0	
NF	Noise Figure	f = 2.0 GHz	dB		5.5	6.0
VSWR	Input/Output	f = 0.1-6.5 GHz	-		1.5:1	
IP ₃	Third Order Intercept Point	f = 2.0 GHz	dBm		27.0	
T _D	Group Delay	f = 2.0 GHz	psec		100	
ISOL	Reverse Isolation	f = 0.1-6.5 GHz	dB		20	
V _D	Device Voltage		V	3.5	4.0	4.5
dG/dT	Device Gain Temperature Coefficient		dB/degC		-0.0018	
dV/dT	Device Voltage Temperature Coefficient		mV/degC		-4.0	

The information provided herein is believed to be reliable at press time. Stanford Microdevices assumes no responsibility for inaccuracies or omissions. Stanford Microdevices assumes no responsibility for the use of this information, and all such information shall be entirely at the user's own risk. Prices and specifications are subject to change without notice. No patent rights or licenses to any of the circuits described herein are implied or granted to any third party. Stanford Microdevices does not authorize or warrant any Stanford Microdevices product for use in life-support devices and/or systems.

Copyright 1999 Stanford Microdevices, Inc. All worldwide rights reserved.

522 Almanor Ave., Sunnyvale, CA 94086

Phone: (800) SMI-MMIC

<http://www.stanfordmicro.com>

SNA-276

DC-6.5 GHz, Cascadable GaAs MMIC Amplifier



Product Features

- Cascadable 50 Ohm Gain Block
- 16dB Gain, +14dBm P1dB
- 1.5:1 Input and Output VSWR
- Operates From Single Supply
- Low Cost Stripline Mount Ceramic Package
- Hermetically Sealed

Applications

- Narrow and Broadband Linear Amplifiers
- Commercial and Industrial Applications

SNA-276 DC-6.5 GHz Cascadable MMIC Amplifier

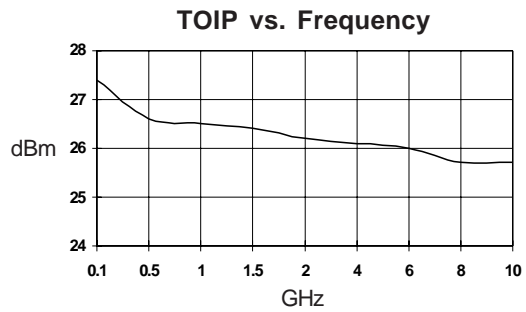
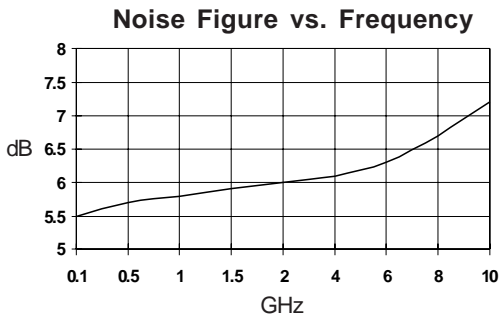
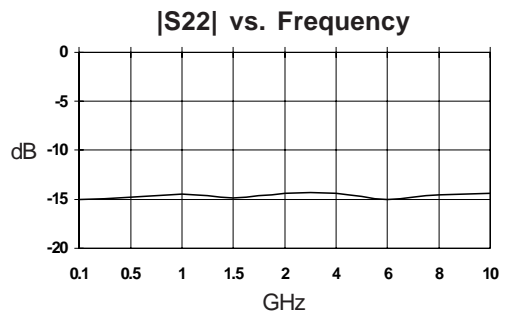
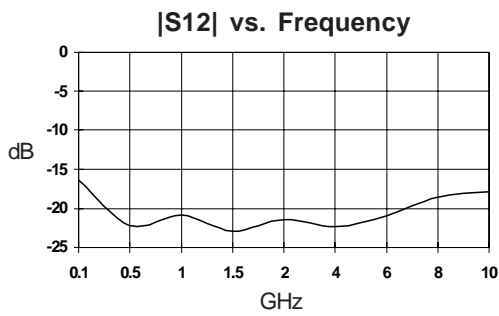
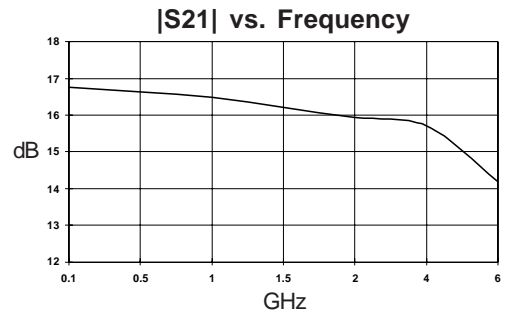
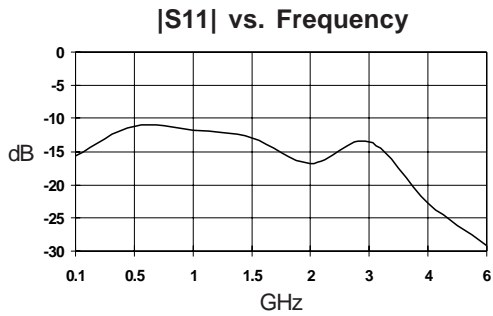

Typical S-Parameters $V_{ds} = 4.0V$, $I_{ds} = 50mA$

Freq GHz	S11	S11 Ang	S21	S21 Ang	S12	S12 Ang	S22	S22 Ang
.100	0.114	157	6.885	166	0.082	-7	0.083	145
.250	0.145	135	6.785	142	0.098	-14	0.095	126
.500	0.152	114	6.659	139	0.106	-28	0.117	115
1.00	0.171	57	6.467	101	0.106	-53	0.141	62
1.50	0.182	1	6.259	60	0.106	-83	0.166	5
2.00	0.170	-50	6.103	22	0.108	-109	0.173	-46
4.00	0.087	38	5.130	-132	0.114	132	0.146	73
6.00	0.130	-76	4.107	81	0.111	12	0.260	-108
8.00	0.208	-132	3.688	-72	0.108	-119	0.103	-22
10.00	0.391	-149	2.962	118	0.081	99	0.346	177

(S-Parameters include the effects of two 1.0 mil diameter bond wires, each 20 mils long, connected to the gate and drain pads on the die)

SNA-276 DC-6.5 GHz Cascadable MMIC Amplifier

Absolute Maximum Ratings

Parameter	Absolute Maximum
Device Current	70mA
Power Dissipation	320mW
RF Input Power	100mW
Junction Temperature	+200C
Operating Temperature	-45C to +85C
Storage Temperature	-65C to +150C

Notes:

1. Operation of this device above any one of these parameters may cause permanent damage.

MTTF vs. Temperature @ Id = 50mA

Lead Temperature	Junction Temperature	MTTF (hrs)
+45C	+155C	1000000
+80C	+190C	100000
+110C	+220C	10000

Thermal Resistance (Lead-Junction): 556° C/W

Part Number Ordering Information

Part Number	Devices Per Reel	Reel Size
SNA-276-TR1	1000	7"
SNA-276-TR2	3000	13"
SNA-276-TR3	5000	13"

Recommended Bias Resistor Values						
Supply Voltage(Vs)	5V	7.5V	9V	12V	15V	20V
Rbias (Ohms)	20	70	100	160	220	320

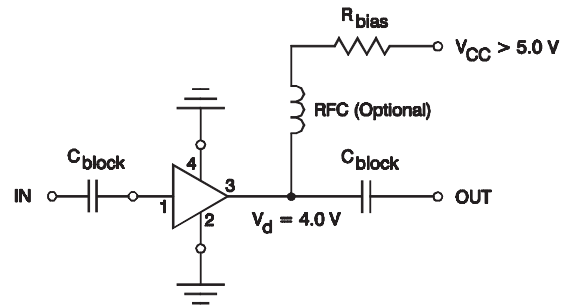

Typical Biasing Configuration

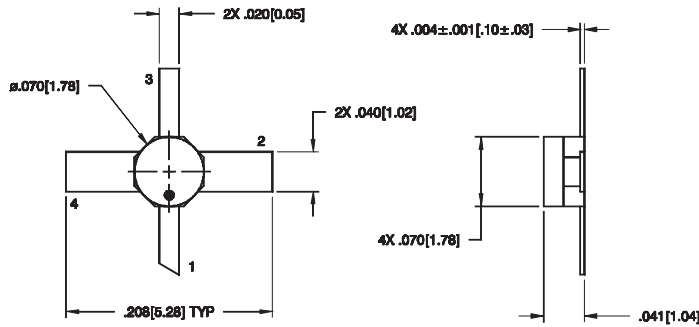

Pin Designation	
1	RF in
2	GND
3	RF out and Bias
4	GND

Typical Performance at 25° C

