

### Chip Resistor Array

- Type: **EXB1:0201x2**  
**EXB2:0402x2, 0402x4, 0402x8**  
**EXB3:0603x2, 0603x4**  
**EXBV:0603x2, 0603x4**  
**EXBS:0805x4**

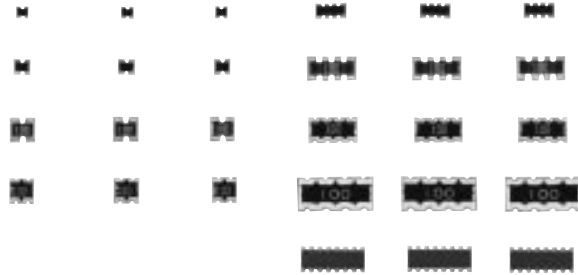

#### ■ Features

- High density
  - 2 resistors in 0.8 mm × 0.6 mm size (14V, Convex Terminal)
  - 2 resistors in 1.0 mm × 1.0 mm size (24V, Convex Terminal)
  - 2 resistors in 1.6 mm × 1.6 mm size (34V, Convex Terminal)
  - 2 resistors in 1.6 mm × 1.6 mm size (V4V, Concave Terminal)
  - 4 resistors in 2.0 mm × 1.0 mm size (28V, Convex Terminal)
  - 4 resistors in 3.2 mm × 1.6 mm size (38V, Convex Terminal)
  - 4 resistors in 3.2 mm × 1.6 mm size (V8V, Concave Terminal)
  - 4 resistors in 5.08 mm × 2.2 mm size (S8V, Concave Terminal)
  - 8 resistors in 3.8 mm × 1.6 mm size (2HV, Convex Terminal)
- Improvement of placement efficiency  
 Placement efficiency of Chip Resistor Array is two or four or eight times of the flat type chip resistor
- Approved under the ISO 9001 system

#### ■ Explanation of Part Numbers

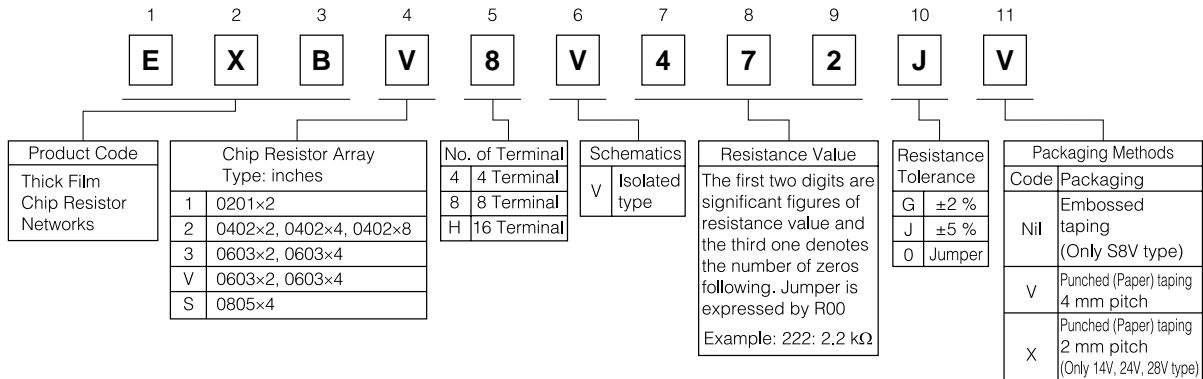

#### ■ Construction (Example : EXBV8V)

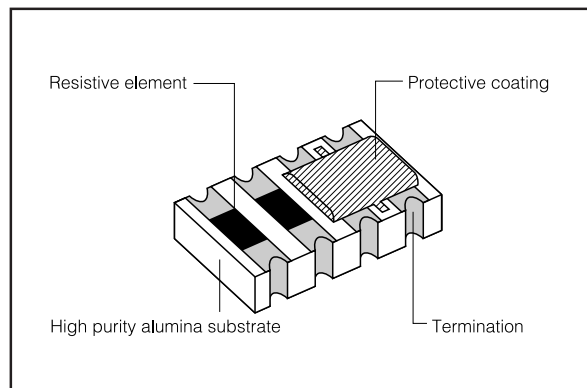

#### ■ Schematics

- Isolated type

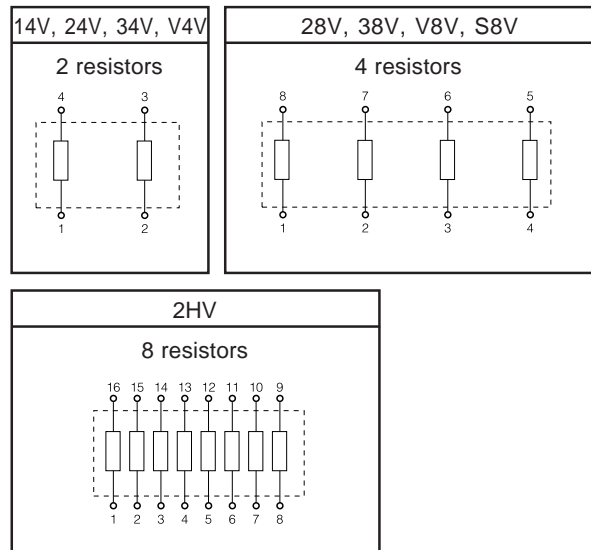

Design, Specifications are subject to change without notice. Ask factory for technical specifications before purchase and/or use. Whenever a doubt about safety arises from this product, please inform us immediately for technical consultation without fail.

■ Dimensions in mm (not to scale)

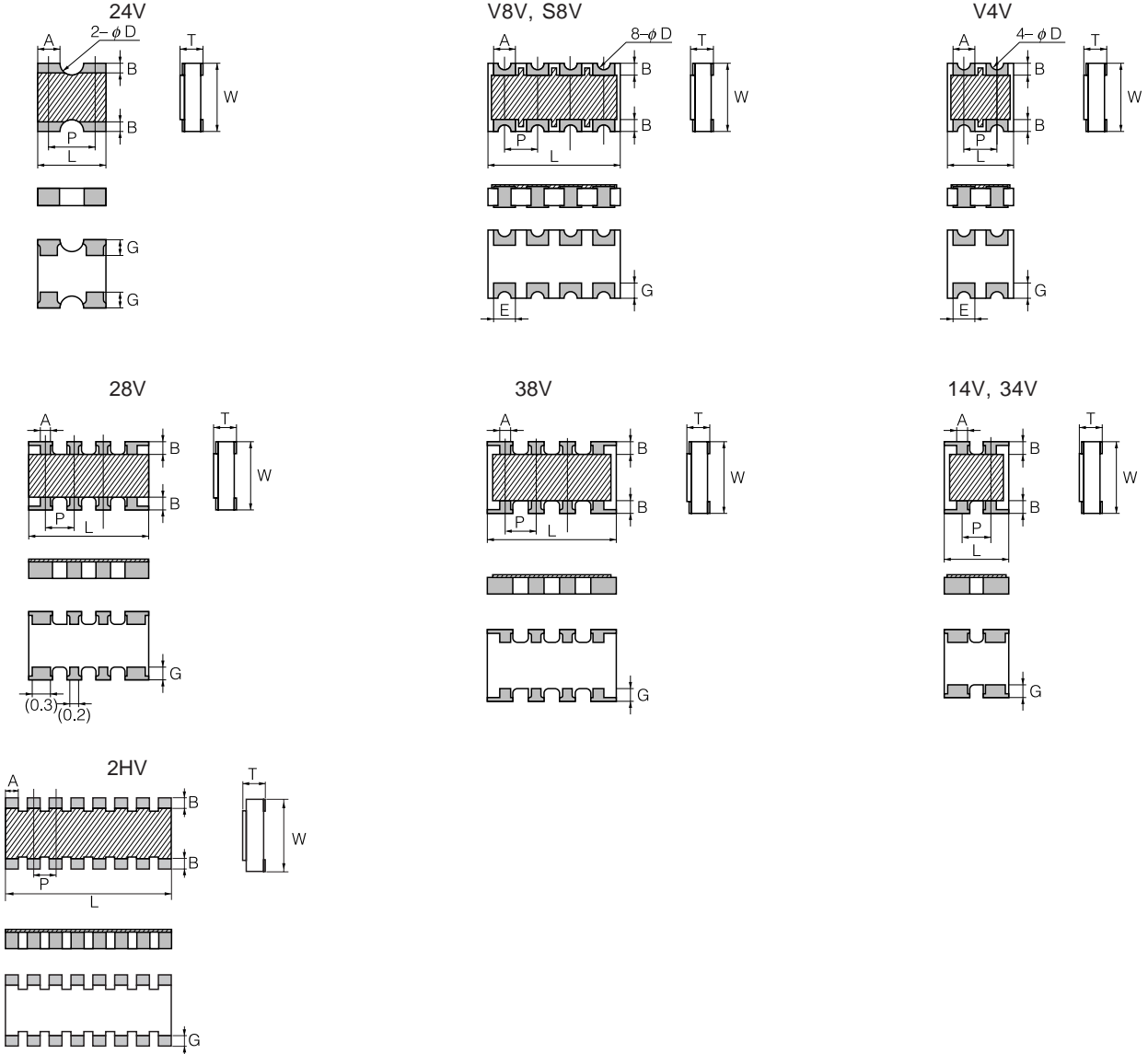

Type (inches)	Dimensions (mm)								
	L	W	T	A	B	φD	P	E	G
<b>NEW</b> EXB14V (0201×2)	0.80±0.10	0.60±0.10	0.35±0.10	0.35±0.10	(0.15±0.10)	—	0.50±0.10	—	0.15±0.10
EXB24V (0402×2)	1.00±0.05	1.00±0.05	0.35±0.05	0.33±0.05	0.15±0.10	0.34±0.05	0.65±0.10	—	0.25±0.05
EXB28V (0402×4)	2.00±0.10	1.00±0.10	0.35±0.10	0.20±0.10	0.20±0.10	—	0.50±0.10	—	0.25±0.10
EXBV4V (0603×2)	1.60 <sup>+0.20</sup> <sub>-0.10</sub>	1.60 <sup>+0.20</sup> <sub>-0.10</sub>	0.60±0.10	0.60±0.10	0.30±0.15	(0.3)	0.80±0.10	0.45±0.10	0.40±0.15
EXB34V (0603×2)	1.60±0.20	1.60±0.15	0.50±0.10	0.45±0.15	(0.30±0.20)	—	0.80±0.15	—	0.30±0.20
EXBV8V (0603×4)	3.20 <sup>+0.30</sup> <sub>-0.20</sub>	1.60 <sup>+0.20</sup> <sub>-0.10</sub>	0.60±0.10	0.60±0.10	0.30±0.15	(0.3)	0.80±0.10	0.45±0.10	0.45±0.15
EXB38V (0603×4)	3.20±0.20	1.60±0.15	0.50±0.10	0.45±0.15	(0.30±0.20)	—	0.80±0.15	—	0.35±0.20
EXBS8V (0805×4)	5.08 <sup>+0.20</sup> <sub>-0.10</sub>	2.20 <sup>+0.20</sup> <sub>-0.10</sub>	0.70±0.20	0.80±0.15	0.50±0.15	(0.5)	1.27±0.20	0.70±0.20	0.55±0.15
<b>NEW</b> EXB2HV (0402×8)	3.80±0.10	1.60±0.10	0.45±0.10	0.30±0.10	(0.30±0.10)	—	0.50±0.10	—	0.30±0.10

( ) Reference

Design, Specifications are subject to change without notice. Ask factory for technical specifications before purchase and/or use. Whenever a doubt about safety arises from this product, please inform us immediately for technical consultation without fail.

### ■ Ratings

Item	Specifications
Resistance Range	10 Ω to 1 MΩ: E24 series
Resistance Tolerance	14V, 2HV, 24V, 28V, 38V, 34V: J: ±5 %
	V4V, V8V, S8V: G: ±2 %, J: ±5 %
Number of Terminal	14V, 24V, V4V, 34V: 4 terminal
	28V, 38V, V8V, S8V: 8 terminal
	2HV: 16 terminal
Number of Resistors	14V, 24V, V4V, 34V: 2 resistors
	28V, 38V, V8V, S8V: 4 resistors
	2HV: 8 resistors
Power Rating at 70 °C	14V, 28V: 0.031 W/element
	24V, V4V, 34V, V8V, 38V: 0.063 W/element
	S8V: 0.1 W/element
	2HV: 0.063 W/element (0.25 W/package)

Item	Specifications
Limiting Element Voltage <sup>(1)</sup> (Max. Rated Continuous Working Voltage)	14V: 12.5 V
	2HV: 25 V
	24V, 28V, 38V, 34V, V4V, V8V: 50 V
	S8V: 100 V
Max. Over-load Voltage <sup>(2)</sup>	14V: 25 V
	2HV: 50 V
	24V, 28V, 38V, 34V, V4V, V8V: 100 V
	S8V: 200 V
T.C.R.	±200 × 10 <sup>-6</sup> /°C (ppm/°C)
Category Temperature Range (Operating Temperature Range)	-55 °C to 125 °C
Jumper Array	(A) R000: 14V, 2HV, 24V, 28V, 38V, 34V, V4V, V8V: 1 A
	Rated Current: S8V: 2 A
	(A) R000: 14V, 2HV, 24V, 28V, 38V, 34V, V4V, V8V: 2 A
	Max. Overload Current: S8V: 4 A

(1) Rated Continuous Working Voltage (RCWV) shall be determined from  $RCWV = \sqrt{\text{Power Rating} \times \text{Resistance Value}}$ , or Limiting Element Voltage (max. RCWV) listed above, whichever less.

(2) Overload (Short-time Overload) Test Voltage (SOTV) shall be determined from  $SOTV = 2.5 \times \text{Power Rating}$  or max. Overload (Voltage) listed above whichever less.

### Power Derating Curve

For resistors operated in ambient temperature above 70 °C, power rating shall be derated in accordance with the right figure.

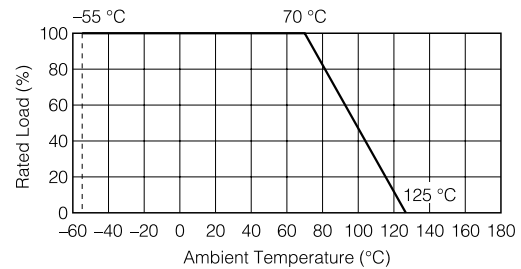

### ■ Packaging Methods

#### ● Standard Quantity

Type (inches)	Thickness (mm)	Weight/1000 pcs. (g)	Punched (Paper) Taping	Embossed Taping
EXB14V (0201×2)	0.35	14V: 0.5	10000 pcs./reel	—
EXB24V, 28V (0402×2, 0402×4)	0.35	24V: 1.2    28V: 2	10000 pcs./reel	—
EXBV4V, V8V (0603×2, 0603×4)	0.6	V4V: 5    V8V: 10	5000 pcs./reel	—
EXB34V, 38V (0603×2, 0603×4)	0.5	34V: 3.5    38V: 7	5000 pcs./reel	—
EXBS8V (0805×4)	0.7	S8V: 30	—	2500 pcs./reel
EXB2HV (0402×8)	0.45	2HV: 9	5000 pcs./reel	—

Design, Specifications are subject to change without notice. Ask factory for technical specifications before purchase and/or use. Whenever a doubt about safety arises from this product, please inform us immediately for technical consultation without fail.

### ● Punched (Paper) Taping Reel

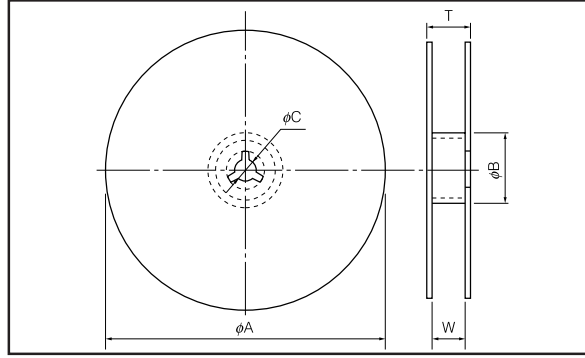

Dimensions (mm)	Type	$\phi A$	$\phi B$	$\phi C$
	14V, 2HV 24V, 28V V4V, 34V V8V, 38V		180.0 <sup>0</sup> <sub>-3.0</sub>	60 min.

Dimensions (mm)	Type	W	T
	14V, 2HV 24V, 28V V4V, 34V V8V, 38V		9.0 <sup>+1.0</sup>

### ● Embossed Taping Reel

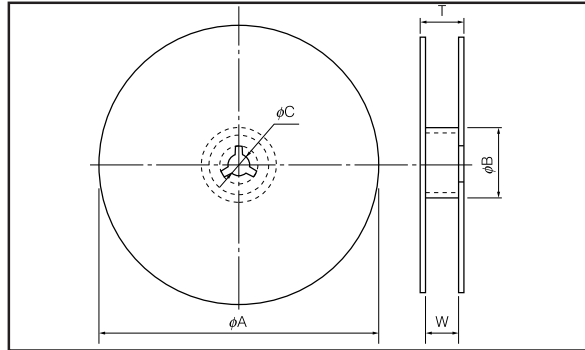

Dimensions (mm)	Type	$\phi A$	$\phi B$	$\phi C$
	S8V		180.0 <sup>0</sup> <sub>-3.0</sub>	60 min.

Dimensions (mm)	Type	W	T
	S8V		13.0 <sup>+1.0</sup>

### ■ Land pattern design

Recommendable land pattern design for Network chip is as shown below figure.

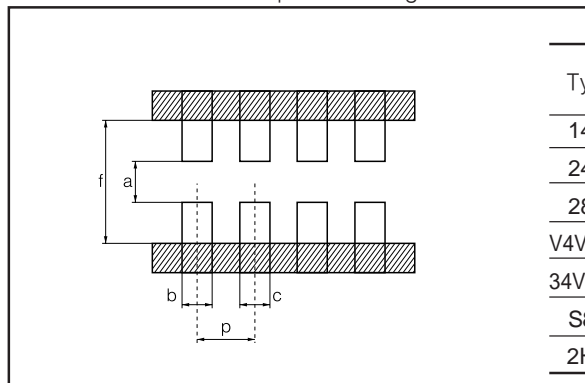

Type	(Not to scale)				
	Dimensions				
	Unit (mm)				
	a	b	c	p	f
14V	0.3	0.3	0.3	0.50	0.9
24V	0.5	0.35 to 0.40	0.35 to 0.40	0.65	1.4 to 1.5
28V	0.4	0.525	0.25	0.50	1.4
V4V, V8V	0.7 to 0.9	0.4 to 0.45	0.4 to 0.45	0.80	2 to 2.4
34V, 38V	0.7 to 0.9	0.4 to 0.5	0.4 to 0.5	0.80	2.2 to 2.6
S8V	1 to 1.2	0.5 to 0.75	0.5 to 0.75	1.27	3.2 to 3.8
2HV	1	0.425	0.25	0.50	2

Design, Specifications are subject to change without notice. Ask factory for technical specifications before purchase and/or use. Whenever a doubt about safety arises from this product, please inform us immediately for technical consultation without fail.

### ● Punched (Paper) Taping

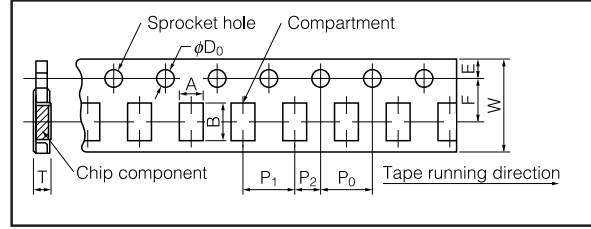

Dimensions (mm)	Type	A	B	W	F	E
	14V	0.70 <sup>+0.05</sup>	0.90 <sup>+0.05</sup>	8.00 <sup>+0.20</sup>	3.50 <sup>+0.05</sup>	1.75 <sup>+0.10</sup>
	24V	1.20 <sup>+0.05</sup>	1.20 <sup>+0.05</sup>			
	28V	1.20 <sup>+0.05</sup>	2.20 <sup>+0.10</sup>			
	V4V	1.95 <sup>+0.15</sup>	1.95 <sup>+0.20</sup>			
	34V	2.00 <sup>+0.15</sup>	3.60 <sup>+0.20</sup>			
	V8V	2.00 <sup>+0.15</sup>	3.60 <sup>+0.20</sup>			
38V	1.90 <sup>+0.15</sup>	4.10 <sup>+0.15</sup>				

Dimensions (mm)	Type	P <sub>1</sub>	P <sub>2</sub>	P <sub>0</sub>	$\phi D_0$	T
	14V	2.00 <sup>+0.10</sup>	2.00 <sup>+0.05</sup>	4.00 <sup>+0.10</sup>	1.50 <sup>+0.10</sup>	0.45 <sup>+0.05</sup>
	24V					0.84 <sup>+0.05</sup>
	28V					0.64 <sup>+0.05</sup>
	V4V	4.00 <sup>+0.10</sup>	2.00 <sup>+0.05</sup>	4.00 <sup>+0.10</sup>	1.50 <sup>+0.10</sup>	0.84 <sup>+0.05</sup>
	34V					0.64 <sup>+0.05</sup>
	V8V					0.84 <sup>+0.05</sup>
	38V					0.64 <sup>+0.05</sup>
2HV					0.64 <sup>+0.05</sup>	

### ● Embossed Taping

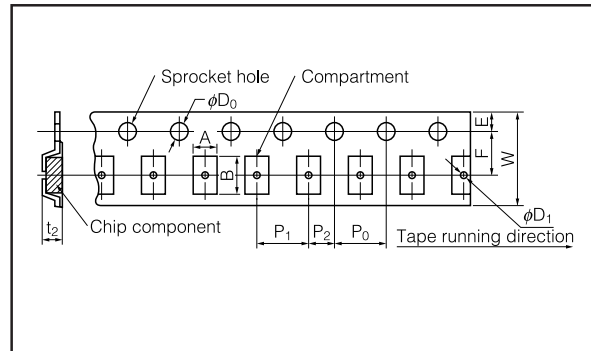

Dimensions (mm)	Type	A	B	W	F	E	P <sub>0</sub>
	S8V	2.80 <sup>+0.20</sup>	5.70 <sup>+0.20</sup>	12.00 <sup>+0.30</sup>	5.50 <sup>+0.05</sup>	1.75 <sup>+0.10</sup>	4.00 <sup>+0.10</sup>

Dimensions (mm)	Type	P <sub>1</sub>	P <sub>2</sub>	$\phi D_0$	t <sub>2</sub>	$\phi D_1$
	S8V	4.00 <sup>+0.10</sup>	2.00 <sup>+0.05</sup>	1.50 <sup>+0.10</sup>	1.6 max.	1.50 <sup>+0.10</sup>

### ⚠ Cautions for Safety

#### 1. Component Placement

- ① Take measure against mechanical stress during and after mounting so as not to damage the termination and protective coating.
- ② Misplacement of components on the land pattern may cause solder bridge problem.

#### 2. Soldering

Precaution and recommendations are described below.

##### (a) Soldering iron

Keep the followings:

- ① Soldering iron tip shall not touch the protective coating of the part.
- ② Solder as quick as possible (within 3 seconds) when the temperature of the soldering iron tip is over 280 °C.

##### (b) Reflow soldering

Recommendable reflow soldering is shown right.

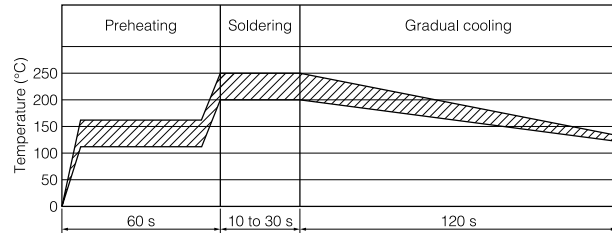

#### 3. Cleaning

Recommendable cleaning method is shown below.

Solvents	Cleaning condition	
	Dipping	Ultrasonic wave washing
Isopropyl Alcohol	5 minutes maximum	1 minute maximum [ Power: 20 W/L Frequency: 10 kHz to 100 kHz ]

4. If transient load (heavy load in a short time) like pulse is expected to be applied, carry out evaluation and confirmation test with the resistors actually mounted on your own board.  
When the load of more than rated power is applied under the load condition at steady state, it may impair performance and/or reliability of resistor. Never exceed the rated power.
5. Chlorine type or other high-activity flux is not recommended as the residue may affect performance or reliability of resistors.
6. When soldering with soldering iron, never touch the body of the chip resistor with a tip of the soldering iron. When using a soldering iron with a tip at high temperature, solder for a time as short as possible (three seconds or less up to 350 °C).
7. Avoid physical shock to the resistor and nipping of the resistor with hard tool (a pair of pliers or tweezers) as it may damage protective film or the body of resistor and may affect resistor's performance.
8. Do not use the product in dewy atmospheres.