

ELECTRONICS

MINITEK™ ACTIVE LATCH HOUSING FOR WIRE-TO-BOARD CONNECTIONS

INTRODUCTION

Minitек™ is FCI's brand for board to board and cable / wire to board connectors in 2.00 mm (0.079") pitch. It is a fully modular system enabling all types of connections between PCBs, wires and flat cables. Its 2mm spacing allows up to 38% space saving compared to traditional modular systems.

FCI is the leading supplier of this type of modular system and continues to grow and expand it. We are now adding a new active latch housing for wire-to-board applications.

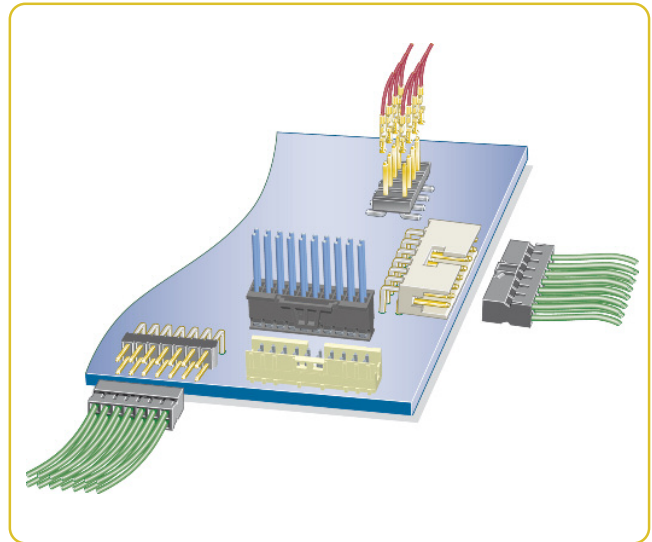

DESCRIPTION

The latch ensures a secure mechanical connection in applications with high extraction forces or vibration. Unlike other systems on the market, the active latch housing mates with the standard headers from the Minitek system. This ensures full modularity and interchangeability throughout the system.

The active latch housing is made with high temperature black plastic material which is able to withstand temperature up to 125°. It is available in 15 versions from 2 x 3 to 2 x 25 positions.

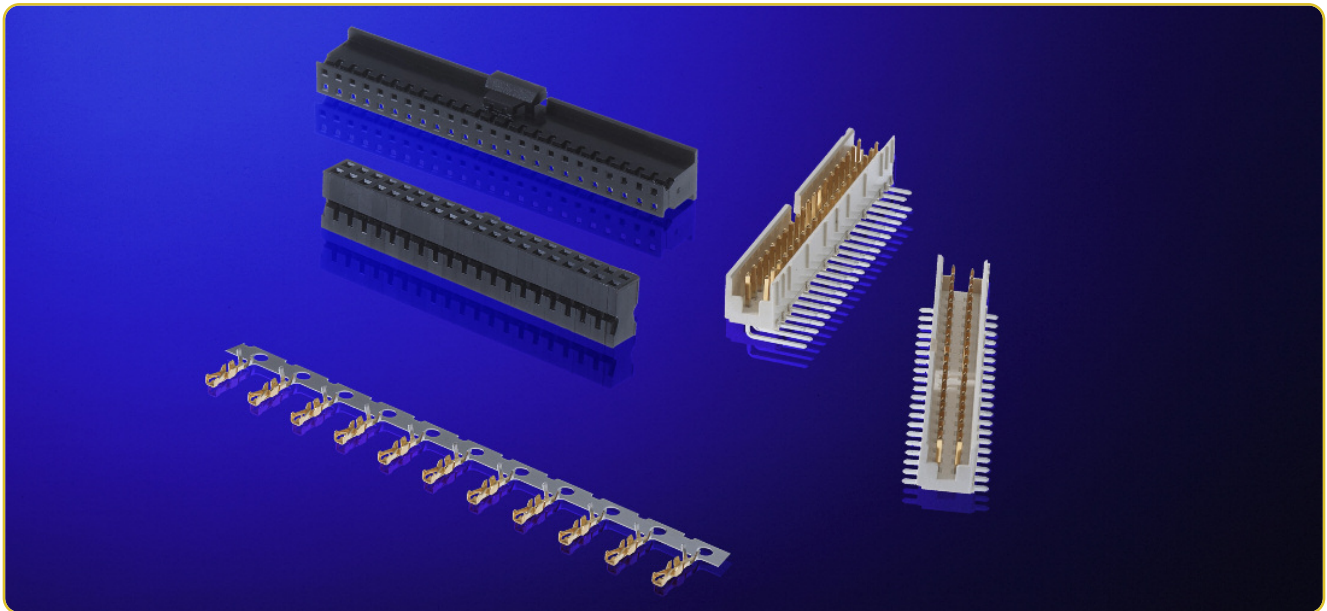

APPLICATION

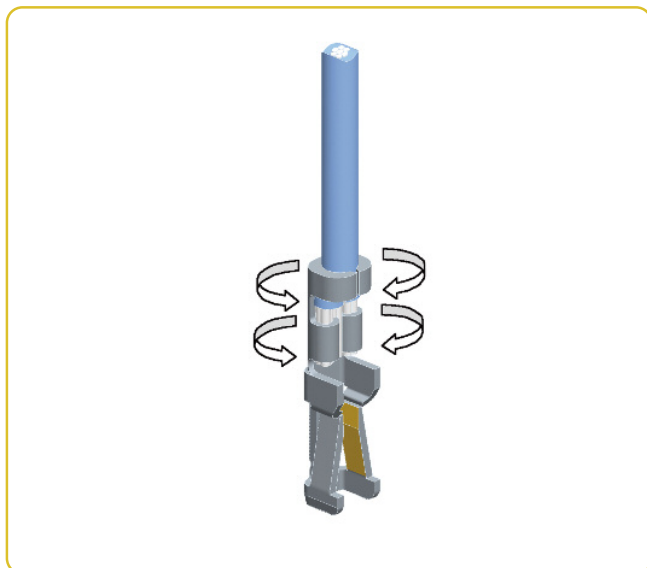

Crimp the terminal onto the wire.

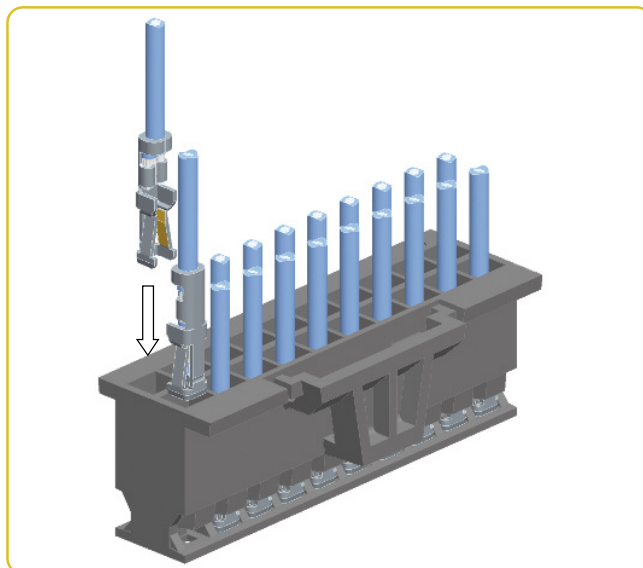

Insert the terminals into the active latch housing.

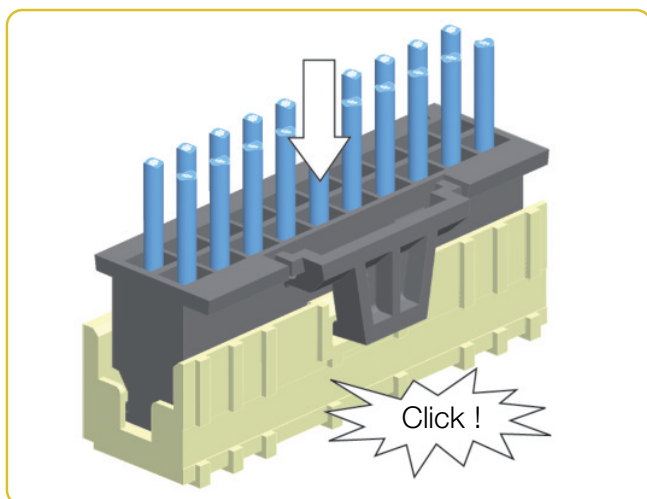

Mate the active latch housing with the headers. it locks with a click.

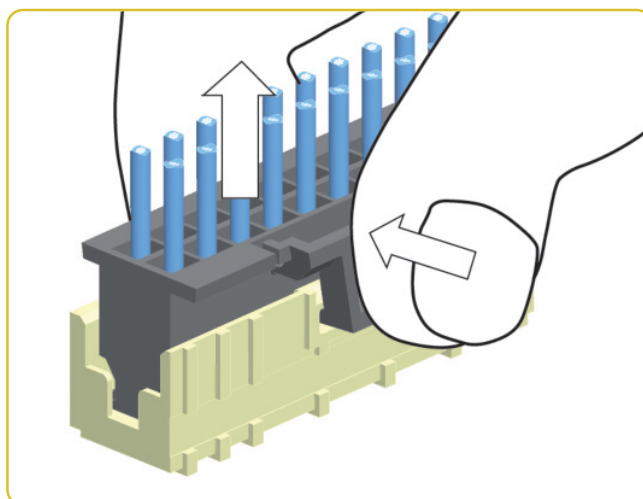

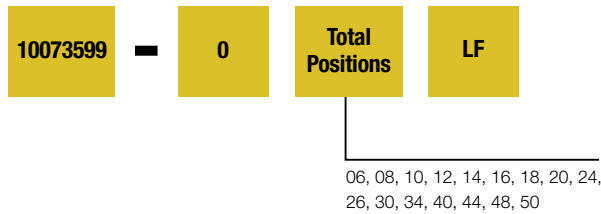

Unmating can be effected by pressing the latch and removing the housing from the header.

PART NUMBER



TECHNICAL DATA

MATERIALS	Housing: Polyamide Colour: black Flammability rating: UL 94 V-O
ELECTRICAL PERFORMANCE	Insulation resistance: 1000 MΩ min Dielectric withstanding voltage: 500 V
MECHANICAL PERFORMANCE	Latching retention force 15 N min. (for 2x3 & 2x4) Latching retention force 25N min. (for 2x5 & 2x25)
OPERATING TEMPERATURE RANGE	-55°C to +125°C
RoHS INFORMATION	This product is RoHS compliant according to the European Union Directive 2002/95/IEC
REFERENCE INFORMATION	 File no. E66906  File no. LR46923 Product drawing: by 8-digit base part number Product specification: GS-12-415

Mating Data:

■ Minitek™ Shrouded Headers 98414-98424-10075025

Terminals:

■ Minitek™ Crimp To Wire Contacts 77138



BASICS+ SERVICE PROGRAM

Minitek is a part of the *Basics+* product range. The *Basics+* program is built around 2.54 mm and 2 mm pitch connectors for board-to-board, wire-to-board and cable-to-board applications.

Basics+ makes the entire product design-in-process very simple, with easy-to-use product selection, technical hot-line, fast sample service, and core range products.

Included are established, proven brands such as BergStik, Dubox, Quickie, Minitek and BergCon PV.