64M-BIT [4M x 16/8M x 8] CMOS EQUAL SECTOR FLASH MEMORY

FEATURES

GENERAL FEATURES

- 8M Bytes/4M Words switchable
- 128 Equal Sectors with 64K Bytes (32K words) each
 - Any combination of sectors can be erased with erase suspend/resume function
- Single Power Supply Operation
 - 2.7 to 3.6 volt for read, erase, and program operations
- Latch-up protected to 100mA from -1.0V to 1.5 x V_{cc}
- Low V_{cc} write inhibit is equal to or less than VLKO
- Compatible with JEDEC standard
 - Pinout and software compatible to single power supply Flash

PERFORMANCE

- High Performance
 - Access time: 90ns
 - Program time: 11 us/word
 - Erase time: 0.7s/sector, 45s/chip (typical)
- Low Power Consumption
 - Low active read current: 9mA (typical) at 5MHz
 - Low standby current: 5uA (typical)
- 100,000 erase/program cycles (typical)
- 10 years data retention

SOFTWARE FEATURES

- Support Common Flash Interface (CFI)
 - Flash device parameters stored on the device and provide the host system to access
- Erase Suspend/ Erase Resume
 - Suspends sector erase operation to read data from or program data to another sector which is not being erased
- Status Reply
 - Data# polling & Toggle bits provide detection of program and erase operation completion or not

HARDWARE FEATURES

- Ready/Busy (RY/BY#) Output
 - Provides a hardware method of detecting program and erase operation completion
- Hardware Reset (RESET#) Input
 - Provides a hardware method to reset the internal state machine to read mode
- ACC input pin
 - Provides accelerated program capability
- WP#/ACC input
 - Write protect (WP#) function allows protection highest or lowest sector, regardless of sector protection settings

SECURITY

- Sector Protection/Chip Unprotect
 - Provides sector protect function to prevent program or erase operation in the protected sector
 - Provides chip unprotect function to allow code changes
 - Provides temporary sector unprotect function for code changes in previously protected sector
- Sector Permanent Lock
 - A unique lock bit feature allows the content to be permanently locked

(Please contact Macronix sales for specific information regarding this permanent lock feature)

- Secured Silicon Sector
 - Provides a 128-word area for code or data that can be permanently protected
 - Once this sector is protected, it is prohibited to program or erase within the sector again

PACKAGE

- 64-ball BGA
- **All Pb-free devices are RoHS Compliant**

GENERAL DESCRIPTION

MX29LA641D H/L is a 64Mbit flash memory that can be organized as 8Mbytes of 8 bits each or as 4Mbytes of 16 bits each. These devices operate over a voltage range of 2.7V to 3.6V typically using a 3V power supply input. The memory array is divided into 128 equal 64 Kilo byte blocks.

The MX29LA641D H/L is offered in a 64-ball BGA(LFBGA) JEDEC standard package. The package is offered in leaded, as well as lead-free version that is compliant to the RoHS specifications. The software algorithm used for this device also adheres to the JEDEC standard for single power supply devices. These flash parts can be programmed in system or on commercially available EPROM/Flash programmers.

Separate OE# and CEx (Output Enable and Chip Enable) signals are provided to simplify system design. When used with high speed processors, the 90ns read access time of this flash memory permits operation with minimal time lost due to system timing delays.

The automatic write algorithm provided on Macronix flash memories perform an automatic erase prior to write. The user only needs to provide a write command to the command register. The on-chip state machine automatically controls the program and erase functions including all necessary internal timings. Since erase and write operations take much longer time than read operations, erase/write can be interrupted to perform read operations in other sectors of the device. For this, Erase Suspend operation along with Erase Resume operation are provided. Data# polling or Toggle bits are used to indicate the end of the erase/write operation.

The device is manufactured at the Macronix fabrication facility using the time tested and proven MXIC advanced technology. This proprietary non-epi process provides a very high degree of latch-up protection for stresses up to 100 milliamperes on address and data pins from -1V to 1.5xVCC.

With low power consumption and enhanced hardware and software features, this flash memory retains data reliably for at least ten years. Erase and programming functions have been tested to meet a typical specification of 100,000 cycles of operation.

PIN CONFIGURATION

Please contact Macronix sales for specific information regarding 64-ball BGA (10x13mm) package pin configuration.

PIN DESCRIPTION

SYMBOL	PIN NAME
A0~A21/A-1	Address Input/LSB addr (Byte Mode)
Q0~Q15	16 Data Inputs/Outputs
CE0~CE2	Chip Enable Input (CEx)
WE#	Write Enable Input
OE#	Output Enable Input
RESET#	Hardware Reset Pin, Active Low
WP#/ACC	Hardware Write Protect Input/ Hardware Acceleration Pin
RY/BY#	Read/Busy Output
BYTE#	Select 8 bit or 16 bit mode
VCC	+3.0V single power supply
V I/O	Output Power Supply (2.7V~3.6V), which is tied to VCC
GND	Device Ground
NC	Pin Not Connected Internally

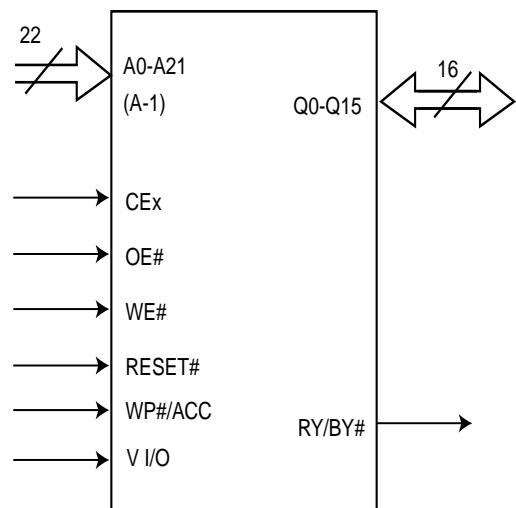
LOGIC SYMBOL

Chip Enable Truth Table

DEVICE	CE0	CE1	CE2
Enabled	VIL	VIL	VIL
Disabled	VIL	VIH	VIL
Enabled	VIL	VIL	VIH
Enabled	VIL	VIH	VIH
Disabled	VIH	VIL	VIL
Disabled	VIH	VIH	VIL
Enabled	VIH	VIL	VIH
Disabled	VIH	VIH	VIH

Note: For Single-chip applications, CE2 and CE1 can be strapped to GND.

BLOCK DIAGRAM

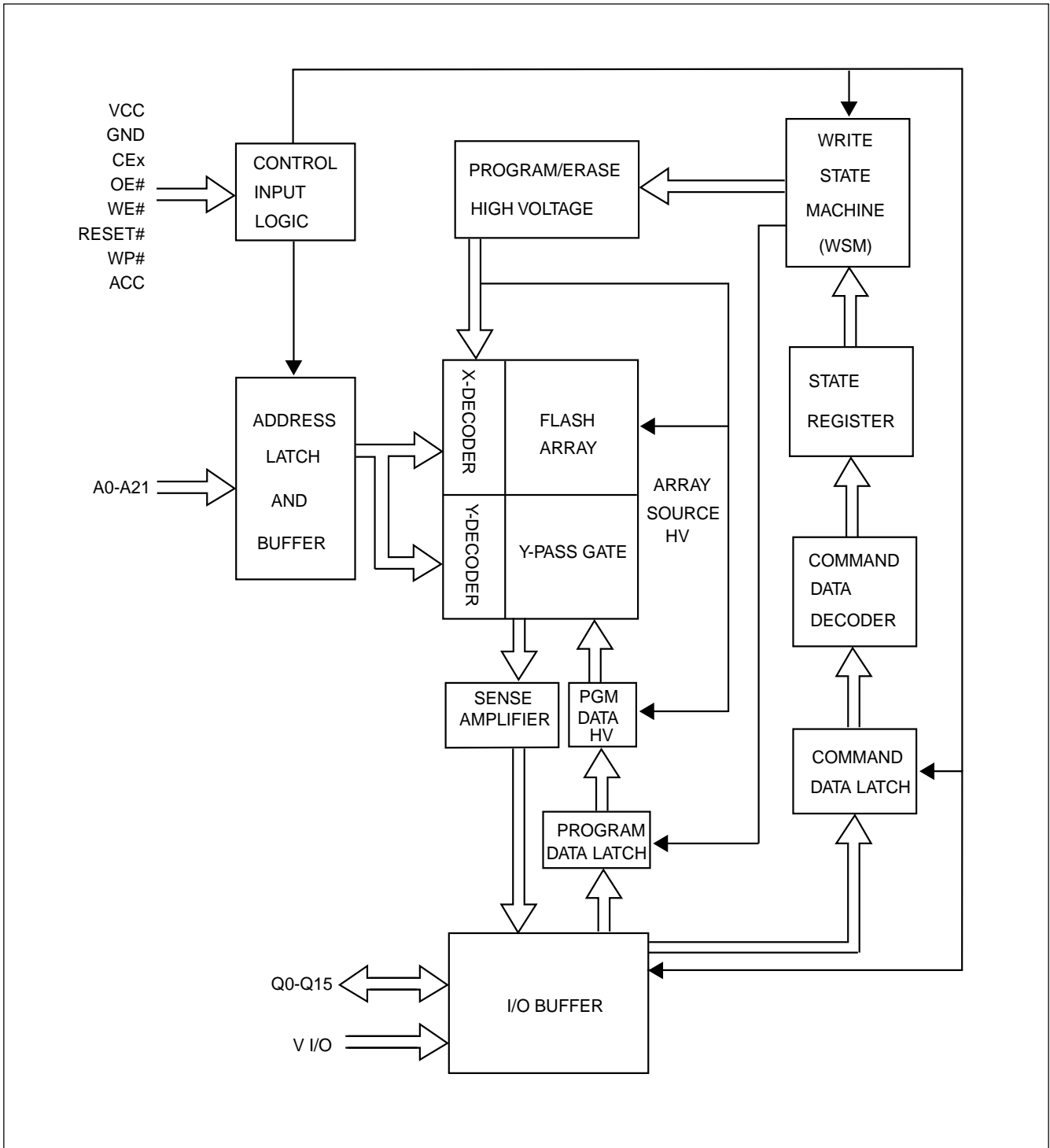

Table 1. BLOCK STRUCTURE

MX29LA641D SECTOR ARCHITECTURE

Sector Size		Sector	Sector Address A21-A15	(x8)	(x16)
Kbytes	Kwords			Address Range	Address Range
64	32	SA0	0000000	000000h-00FFFFh	000000h-007FFFh
64	32	SA1	0000001	010000h-01FFFFh	008000h-00FFFFh
64	32	SA2	0000010	020000h-02FFFFh	010000h-017FFFh
64	32	SA3	0000011	030000h-03FFFFh	018000h-01FFFFh
64	32	SA4	0000100	040000h-04FFFFh	020000h-027FFFh
64	32	SA5	0000101	050000h-05FFFFh	028000h-02FFFFh
64	32	SA6	0000110	060000h-06FFFFh	030000h-037FFFh
64	32	SA7	0000111	070000h-07FFFFh	038000h-03FFFFh
64	32	SA8	0001000	080000h-08FFFFh	040000h-047FFFh
64	32	SA9	0001001	090000h-09FFFFh	048000h-04FFFFh
64	32	SA10	0001010	0A0000h-0AFFFFh	050000h-057FFFh
64	32	SA11	0001011	0B0000h-0BFFFFh	058000h-05FFFFh
64	32	SA12	0001100	0C0000h-0CFFFFh	060000h-067FFFh
64	32	SA13	0001101	0D0000h-0DFFFFh	068000h-06FFFFh
64	32	SA14	0001110	0E0000h-0EFFFFh	070000h-077FFFh
64	32	SA15	0001111	0F0000h-0FFFFFh	078000h-07FFFFh
64	32	SA16	0010000	100000h-10FFFFh	080000h-087FFFh
64	32	SA17	0010001	110000h-11FFFFh	088000h-08FFFFh
64	32	SA18	0010010	120000h-12FFFFh	090000h-097FFFh
64	32	SA19	0010011	130000h-13FFFFh	098000h-09FFFFh
64	32	SA20	0010100	140000h-14FFFFh	0A0000h-0A7FFFh
64	32	SA21	0010101	150000h-15FFFFh	0A8000h-0AFFFFh
64	32	SA22	0010110	160000h-16FFFFh	0B0000h-0B7FFFh
64	32	SA23	0010111	170000h-17FFFFh	0B8000h-0BFFFFh
64	32	SA24	0011000	180000h-18FFFFh	0C0000h-0C7FFFh
64	32	SA25	0011001	190000h-19FFFFh	0C8000h-0CFFFFh
64	32	SA26	0011010	1A0000h-1AFFFFh	0D0000h-0D7FFFh
64	32	SA27	0011011	1B0000h-1BFFFFh	0D8000h-0DFFFFh
64	32	SA28	0011100	1C0000h-1CFFFFh	0E0000h-0E7FFFh
64	32	SA29	0011101	1D0000h-1DFFFFh	0E8000h-0EFFFFh
64	32	SA30	0011110	1E0000h-1EFFFFh	0F0000h-0F7FFFh
64	32	SA31	0011111	1F0000h-1FFFFFh	0F8000h-0FFFFFh
64	32	SA32	0100000	200000h-20FFFFh	100000h-107FFFh
64	32	SA33	0100001	210000h-21FFFFh	108000h-10FFFFh
64	32	SA34	0100010	220000h-22FFFFh	110000h-117FFFh
64	32	SA35	0100011	230000h-23FFFFh	118000h-11FFFFh
64	32	SA36	0100100	240000h-24FFFFh	120000h-127FFFh
64	32	SA37	0100101	250000h-25FFFFh	128000h-12FFFFh

Sector Size		Sector	Sector Address A21-A15	(x8)	(x16)
Kbytes	Kwords			Address Range	Address Range
64	32	SA38	0100110	260000h-26FFFFh	130000h-137FFFh
64	32	SA39	0100111	270000h-27FFFFh	138000h-13FFFFh
64	32	SA40	0101000	280000h-28FFFFh	140000h-147FFFh
64	32	SA41	0101001	290000h-29FFFFh	148000h-14FFFFh
64	32	SA42	0101010	2A0000h-2AFFFFh	150000h-157FFFh
64	32	SA43	0101011	2B0000h-2BFFFFh	158000h-15FFFFh
64	32	SA44	0101100	2C0000h-2CFFFFh	160000h-167FFFh
64	32	SA45	0101101	2D0000h-2DFFFFh	168000h-16FFFFh
64	32	SA46	0101110	2E0000h-2EFFFFh	170000h-177FFFh
64	32	SA47	0101111	2F0000h-2FFFFFh	178000h-17FFFFh
64	32	SA48	0110000	300000h-30FFFFh	180000h-187FFFh
64	32	SA49	0110001	310000h-31FFFFh	188000h-18FFFFh
64	32	SA50	0110010	320000h-32FFFFh	190000h-197FFFh
64	32	SA51	0110011	330000h-33FFFFh	198000h-19FFFFh
64	32	SA52	0110100	340000h-34FFFFh	1A0000h-1A7FFFh
64	32	SA53	0110101	350000h-35FFFFh	1A8000h-1AFFFFh
64	32	SA54	0110110	360000h-36FFFFh	1B0000h-1B7FFFh
64	32	SA55	0110111	370000h-37FFFFh	1B8000h-1BFFFFh
64	32	SA56	0111000	380000h-38FFFFh	1C0000h-1C7FFFh
64	32	SA57	0111001	390000h-39FFFFh	1C8000h-1CFFFFh
64	32	SA58	0111010	3A0000h-3AFFFFh	1D0000h-1D7FFFh
64	32	SA59	0111011	3B0000h-3BFFFFh	1D8000h-1DFFFFh
64	32	SA60	0111100	3C0000h-3CFFFFh	1E0000h-1E7FFFh
64	32	SA61	0111101	3D0000h-3DFFFFh	1E8000h-1EFFFFh
64	32	SA62	0111110	3E0000h-3EFFFFh	1F0000h-1F7FFFh
64	32	SA63	0111111	3F0000h-3FFFFFh	1F8000h-1FFFFFh
64	32	SA64	1000000	400000h-40FFFFh	200000h-207FFFh
64	32	SA65	1000001	410000h-41FFFFh	208000h-20FFFFh
64	32	SA66	1000010	420000h-42FFFFh	210000h-217FFFh
64	32	SA67	1000011	430000h-43FFFFh	218000h-21FFFFh
64	32	SA68	1000100	440000h-44FFFFh	220000h-227FFFh
64	32	SA69	1000101	450000h-45FFFFh	228000h-22FFFFh
64	32	SA70	1000110	460000h-46FFFFh	230000h-237FFFh
64	32	SA71	1000111	470000h-47FFFFh	238000h-23FFFFh
64	32	SA72	1001000	480000h-48FFFFh	240000h-247FFFh
64	32	SA73	1001001	490000h-49FFFFh	248000h-24FFFFh
64	32	SA74	1001010	4A0000h-4AFFFFh	250000h-257FFFh
64	32	SA75	1001011	4B0000h-4BFFFFh	258000h-25FFFFh
64	32	SA76	1001100	4C0000h-4CFFFFh	260000h-267FFFh
64	32	SA77	1001101	4D0000h-4DFFFFh	268000h-26FFFFh



Sector Size		Sector	Sector Address A21-A15	(x8)	(x16)
Kbytes	Kwords			Address Range	Address Range
64	32	SA78	1001110	4E0000h-4EFFFFh	270000h-277FFFh
64	32	SA79	1001111	4F0000h-4FFFFFFh	278000h-27FFFFh
64	32	SA80	1010000	500000h-50FFFFh	280000h-287FFFh
64	32	SA81	1010001	510000h-51FFFFh	288000h-28FFFFh
64	32	SA82	1010010	520000h-52FFFFh	290000h-297FFFh
64	32	SA83	1010011	530000h-53FFFFh	298000h-29FFFFh
64	32	SA84	1010100	540000h-54FFFFh	2A0000h-2A7FFFh
64	32	SA85	1010101	550000h-55FFFFh	2A8000h-2AFFFFh
64	32	SA86	1010110	560000h-56FFFFh	2B0000h-2B7FFFh
64	32	SA87	1010111	570000h-57FFFFh	2B8000h-2BFFFFh
64	32	SA88	1011000	580000h-58FFFFh	2C0000h-2C7FFFh
64	32	SA89	1011001	590000h-59FFFFh	2C8000h-2CFFFFh
64	32	SA90	1011010	5A0000h-5AFFFFh	2D0000h-2D7FFFh
64	32	SA91	1011011	5B0000h-5BFFFFh	2D8000h-2DFFFFh
64	32	SA92	1011100	5C0000h-5CFFFFh	2E0000h-2E7FFFh
64	32	SA93	1011101	5D0000h-5DFFFFh	2E8000h-2EFFFFh
64	32	SA94	1011110	5E0000h-5EFFFFh	2F0000h-2F7FFFh
64	32	SA95	1011111	5F0000h-5FFFFFFh	2F8000h-2FFFFFFh
64	32	SA96	1100000	600000h-60FFFFh	300000h-307FFFh
64	32	SA97	1100001	610000h-61FFFFh	308000h-30FFFFh
64	32	SA98	1100010	620000h-62FFFFh	310000h-317FFFh
64	32	SA99	1100011	630000h-63FFFFh	318000h-31FFFFh
64	32	SA100	1100100	640000h-64FFFFh	320000h-327FFFh
64	32	SA101	1100101	650000h-65FFFFh	328000h-32FFFFh
64	32	SA102	1100110	660000h-66FFFFh	330000h-337FFFh
64	32	SA103	1100111	670000h-67FFFFh	338000h-33FFFFh
64	32	SA104	1101000	680000h-68FFFFh	340000h-347FFFh
64	32	SA105	1101001	690000h-69FFFFh	348000h-34FFFFh
64	32	SA106	1101010	6A0000h-6AFFFFh	350000h-357FFFh
64	32	SA107	1101011	6B0000h-6BFFFFh	358000h-35FFFFh
64	32	SA108	1101100	6C0000h-6CFFFFh	360000h-367FFFh
64	32	SA109	1101101	6D0000h-6DFFFFh	368000h-36FFFFh
64	32	SA110	1101110	6E0000h-6EFFFFh	370000h-377FFFh
64	32	SA111	1101111	6F0000h-6FFFFFFh	378000h-37FFFFh
64	32	SA112	1110000	700000h-70FFFFh	380000h-387FFFh
64	32	SA113	1110001	710000h-71FFFFh	388000h-38FFFFh
64	32	SA114	1110010	720000h-72FFFFh	390000h-397FFFh
64	32	SA115	1110011	730000h-73FFFFh	398000h-39FFFFh
64	32	SA116	1110100	740000h-74FFFFh	3A0000h-3A7FFFh
64	32	SA117	1110101	750000h-75FFFFh	3A8000h-3AFFFFh



Sector Size		Sector	Sector Address A21-A15	(x8)	(x16)
Kbytes	Kwords			Address Range	Address Range
64	32	SA118	1110110	760000h-76FFFFh	3B0000h-3B7FFFh
64	32	SA119	1110111	770000h-77FFFFh	3B8000h-3BFFFFh
64	32	SA120	1111000	780000h-78FFFFh	3C0000h-3C7FFFh
64	32	SA121	1111001	790000h-79FFFFh	3C8000h-3CFFFFh
64	32	SA122	1111010	7A0000h-7AFFFFh	3D0000h-3D7FFFh
64	32	SA123	1111011	7B0000h-7BFFFFh	3D8000h-3DFFFFh
64	32	SA124	1111100	7C0000h-7CFFFFh	3E0000h-3E7FFFh
64	32	SA125	1111101	7D0000h-7DFFFFh	3E8000h-3EFFFFh
64	32	SA126	1111110	7E0000h-7EFFFFh	3F0000h-3F7FFFh
64	32	SA127	1111111	7F0000h-7FFFFFFh	3F8000h-3FFFFFFh

BUS OPERATION

Table 2-1. BUS OPERATION

Mode Select	RESET#	CE _x	WE#	OE#	Address	Q8~Q15		Data (I/O)	WP#/
						Word	Byte	Q0~Q7	ACC
Device Reset	L	X	X	X	X	HighZ	HighZ	HighZ	L/H
Standby Mode	V _{cc} ±0.3V	disable	X	X	X	HighZ	HighZ	HighZ	H
Output Disable	H	enable	H	H	X	HighZ	HighZ	HighZ	L/H
Read Mode	H	enable	H	L	AIN	DOUT	Q8~Q15 =HighZ	DOUT	L/H
Write (Program/Erase)	H	enable	L	H	AIN	Note 3	Q8~Q15 =HighZ	Note 3	Note 2
Accelerate Program	H	enable	L	H	AIN	Note 3	Q8~Q15 =HighZ	Note 3	V _{hv}
Temporary Sector Unprotect	V _{hv}	X	X	X	AIN	Note 3	HighZ	Note 3	Note 2
Sector Protect (Note 2)	V _{hv}	enable	L	H	Sector Address, A6=L, A1=H, A0=L	X	X	Note 3	H
Chip Unprotect (Note 2)	V _{hv}	enable	L	H	Sector Address, A6=H, A1=H, A0=L	X	X	Note 3	H

Legend:

L=Logic LOW=V_{il}, H=Logic High=V_{ih}, V_{hv}=10.0±0.5V, X=Don't Care, AIN=Address IN, DIN=Data IN, DOUT=Data OUT

Notes:

1. Through programming equipment, the sector protect and chip unprotect functions can also be implemented.
2. If WP#=L, all sectors are protected. If WP# remove to H, all sectors recover previous protected or unprotect status, determined by "sector protect" or "chip unprotect" function.
3. By following the requests of command sequence, sector protection, or data polling algorithm, Q0~Q15 would be Data Input or Data Output.
4. In Word mode, A21~A0 are address pins. In Byte mode A21~A-1 are address pins. In both modes, A21~A15 are sector address.

Table 2-2. BUS OPERATION

Description	Control Input			A21 to A15	A14 to A10	A9	A8 to A7	A6	A5 to A4	A3 to A2	A1	A0	Q8 to Q15	Q7 to Q0	
	CEx	OE#	WE#												
Sector Lock Status Verification	enable	L	H	SA	X	Vhv	X	L	X	L	H	L	X	Note 1	
Read Indicator Bit(Q7) For Security Sector	enable	L	H	X	X	Vhv	X	L	X	L	H	H	X	Note 2	
Read Manufacturer ID	enable	L	H	X	X	Vhv	X	L	X	L	L	L	00	C2h	
Read Device ID---															
1st cycle	enable	L	H	X	X	Vhv	X	L	X	L	L	H	22	7Eh	
2nd cycle										H	H	L	22	13h	
3rd cycle										641DH	H	H	H	22	01h
										641DL	H	H	H	22	00h

Legend: L=Logic Low=VIL, H=Logic High=VIH, SA=Sector Address, X=Don't care.

Notes:

- Sector unprotected code: 00h, sector protected code:01h.
- Factory locked code: For 29LA641DL: 88h.
For 29LA641DH: 98h.
Factory unlocked code: For 29LA641DL: 08h.
For 29LA641DH: 18h.

WRITE COMMANDS/COMMAND SEQUENCES

To write a command to the device, system must drive WE# and CEx to Vil, and OE# to Vih. In a command cycle, all address are latched at the later falling edge of CEx and WE#, and all data are latched at the earlier rising edge of CE# and WE#.

Figure 1 illustrates the AC timing waveform of a write command, and Table 3 defines all the valid command sets of the device. System is not allowed to write invalid commands not defined in this datasheet. Writing an invalid command will bring the device to an undefined state.

REQUIREMENTS FOR READING ARRAY DATA

Read array action is to read the data stored in the array. While the memory device is in powered up or has been reset, it will automatically enter the status of read array. If the microprocessor wants to read the data stored in the array, it has to drive CEx (device enable control pin) and OE# (Output control pin) as Vil, and input the address of the data to be read into address pin at the same time. After a period of read cycle (Tce or Taa), the data being read out will be displayed on output pin for microprocessor to access. If CEx or OE# is Vih, the output will be in tri-state, and there will be no data displayed on output pin at all.

After the memory device completes embedded operation (automatic Erase or Program), it will automatically return to the status of read array, and the device can read the data in any address in the array. In the process of erasing, if the device receives the Erase suspend command, erase operation will be stopped temporarily after a period of time no more than Tready and the device will return to the status of read array. At this time, the device can read the data stored in any address except the sector being erased in the array. In the status of erase suspend, if user wants to read the data in the sectors being erased, the device will output status data onto the output. Similarly, if program command is issued after erase suspend, after program operation is completed, system can still read array data in any address except the sectors to be erased.

The device needs to issue reset command to enable read array operation again in order to arbitrarily read the data in the array in the following two situations:

1. In program or erase operation, the programming or erasing failure causes Q5 to go high.
2. The device is in auto select mode or CFI mode.

In the two situations above, if reset command is not issued, the device is not in read array mode and system must issue reset command before reading array data.

ACCELERATED PROGRAM OPERATION

The accelerated program can improve programming performance compared with word/byte program. By applying Vhv on WP#/ACC pin, the device will enter accelerated program and draw current no more than IACC from WP#/ACC pin. Removing the Vhv from WP#/ACC pin will put the device back to normal operation (not accelerated).

RESET# OPERATION

Driving RESET# pin low for a period more than T_{rp} will reset the device back to read mode. If the device is in program or erase operation, the reset operation will take at most a period of T_{ready} for the device to return to read array mode. Before the device returns to read array mode, the RY/BY# pin remains low (busy status).

When RESET# pin is held at $GND \pm 0.3V$, the device consumes standby current (I_{sb}). However, device draws larger current if RESET# pin is held at V_{il} but not within $GND \pm 0.3V$.

It is recommended that the system to tie its reset signal to RESET# pin of flash memory, so that the flash memory will be reset during system reset and allows system to read the boot-up firmware from flash memory.

SECTOR PROTECT OPERATION

When a sector is protected, program or erase operation will be disabled on these sectors. MX29LA641D H/L provides two methods for sector protection.

Once the sector is protected, the sector remains protected until next chip unprotect, or is temporarily unprotected by asserting RESET# pin at V_{hv} . Refer to temporary sector unprotect operation for further details.

The first method is by applying V_{hv} on RESET# pin. Refer to Figure 14 for timing diagram and Figure 15 for the algorithm for this method.

The other method is asserting V_{hv} on A9 and OE# pins, with A6 and CEx at V_{il} . The protection operation begins at the falling edge of WE# and terminates at the rising edge. Contact Macronix for details.

CHIP UNPROTECT OPERATION

MX29LA641D H/L provides two methods for chip unprotect. The chip unprotect operation unprotects all sectors within the device. It is recommended to protect all sectors before activating chip unprotect mode. All sectors groups are unprotected when shipped from the factory.

The first method is by applying V_{hv} on RESET# pin. Refer to Figure 14 for timing diagram and Figure 15 for algorithm of the operation.

The other method is asserting V_{hv} on A9 and OE# pins, with A6 at V_{ih} and CE# at V_{il} (see Table 2). The unprotect operation begins at the falling edge of WE# and terminates at the rising edge. Contact Macronix for details.

TEMPORARY SECTOR UNPROTECT OPERATION

System can apply RESET# pin at V_{hv} to place the device in temporary unprotect mode. In this mode, previously protected sectors can be programmed or erased just as it is unprotected. The device returns to normal operation once V_{hv} is removed from RESET# pin and previously protected sectors are again protected.

WRITE PROTECT (WP#)

This Write Protect function provides a hardware protection method to protect all sectors without using Vhv.

By driving the WP#/ACC pin Low, the device disable program and erase function in all sectors. If the WP#/ACC is held high (Vih to Vcc), these sectors revert to their previous protected/unprotected status.

AUTOMATIC SELECT OPERATION

When the device is in Read array mode, erase-suspended read array mode or CFI mode, user can issue read silicon ID command to enter read silicon ID mode. After entering read silicon ID mode, user can query several silicon IDs continuously and does not need to issue read silicon ID mode again. In read silicon ID mode, issuing reset command will reset device back to read array mode or erase-suspended read array mode.

MX29LA641D H/L provides hardware method to access the silicon ID read operation. Which method requires Vhv on A9 pin, Vil on CEx, OE# and A6 pins. Which apply A1=Vil, A0=Vil, the device will output MXIC's manufacture code of C2h. Which apply A1=Vil, A0=Vih, the device will output device code of 227Eh. Table 2 shows the sequence for reading MX29LA641D H/L device codes.

VERIFY SECTOR PROTECT STATUS OPERATION

MX29LA641D H/L provides hardware sector protection against Program and Erase operation for protected sectors. The sector protect status can be read through Sector Protect Verify command. This method requires Vhv on A9 pin, Vih on WE# and A1 pins, Vil on CEx, OE#, A6 and A0 pins, and sector address on A15 to A21 pins. If the read out data is 01H, the designated sector is protected. Oppositely, if the read out data is 00H, the designated sector is not protected.

SECURITY SECTOR FLASH MEMORY REGION

The Security Sector region is an extra OTP memory space of 128 words in length. The security sectors can be locked upon shipping from factory, or it can be locked by customer after shipping. Customer can issue Security Sector Factory Protect Verify and/or Security Sector Protect Verify to query the lock status of the device.

In factory-locked device, security sector region is protected when shipped from factory and the security silicon sector indicator bit is set to "1". In customer lockable device, security sector region is unprotected when shipped from factory and the security silicon indicator bit is set to "0".

Factory Locked: Security Sector Programmed and Protected at the Factory

In a factory locked device, the security silicon region is permanently locked after shipping from factory. The device will have a 16-byte (8-word) ESN in the security region at address : 000000h - 000007h.

The secured silicon sector address space in this device is allocated as follows.

Secured Silicon Sector Address Range	Standard Factory Locked	Express Flash Factory Locked	Customer Lockable
000000h-000007h	ESN	ESN or Determined by Customer	Determined by Customer
000008h-00007Fh	Unavailable	Determined by Customer	

Customer Lockable: Security Sector NOT Programmed or Protected at the Factory

When the security feature is not required, the security region can act as an extra memory space.

Security silicon sector can also be protected by two methods. Note that once the security silicon sector is protected, there is no way to unprotect the security silicon sector and the content of it can no longer be altered.

The first method is to write a three-cycle command of Enter Security Region, and then follow the sector protect algorithm as illustrated in Figure 15, except that RESET# pin may at either Vih or Vhv.

The other method is to write a three-cycle command of Enter Security Region, and then follow the alternate method of sector protect with A9, OE# at Vhv.

After the security silicon is locked and verified, system must write Exit Security Sector Region, go through a power cycle, or issue a hardware reset to return the device to read normal array mode.

DATA PROTECTION

To avoid accidental erasure or programming of the device, the device is automatically reset to read array mode during power up. Besides, only after successful completion of the specified command sets will the device begin its erase or program operation.

Other features to protect the data from accidental alternation are described as followed.

LOW VCC WRITE INHIBIT

The device refuses to accept any write command when Vcc is less than VLKO. This prevents data from spuriously altered. The device automatically resets itself when Vcc is lower than VLKO and write cycles are ignored until Vcc is greater than VLKO. System must provide proper signals on control pins after Vcc is larger than VLKO to avoid unintentional program or erase operation

WRITE PULSE "GLITCH" PROTECTION

CEx, WE#, OE# pulses shorter than 5ns are treated as glitches and will not be regarded as an effective write cycle.

LOGICAL INHIBIT

A valid write cycle requires both CEx and WE# at Vil with OE# at Vih. Write cycle is ignored when either CEx at Vih, WE# a Vih, or OE# at Vil.

POWER-UP SEQUENCE

Upon power up, MX29LA641D H/L is placed in read array mode. Furthermore, program or erase operation will begin only after successful completion of specified command sequences.



MACRONIX
INTERNATIONAL Co., LTD.

MX29LA641D H/L

POWER-UP WRITE INHIBIT

When WE#, CEx is held at Vil and OE# is held at Vih during power up, the device ignores the first command on the rising edge of WE#.

POWER SUPPLY DECOUPLING

A 0.1uF capacitor should be connected between the Vcc and GND to reduce the noise effect.

SOFTWARE COMMAND DEFINITIONS

Table 3 indicates all valid command sequences. Please note that if you give wrong address and data, or write them by wrong command sequence, the device will be reset into read mode.

While WE# or CEx goes low, the falling edge of which happens later will latch all address. While WE# or CEx goes high, and the rising edge of which happens first will latch all data.

TABLE 3. MX29LA641D H/L COMMAND DEFINITIONS

Command	Hex	Read Mode	Reset Mode	Automatic Select							
				Manufacturer ID		Device ID (* Notes)		Security Sector Factory Protect Verify		Sector Protect Verify	
				Word	Byte	Word	Byte	Word	Byte	Word	Byte
1st Bus Cyc	Addr	Addr	XXX	555	AAA	555	AAA	555	AAA	555	AAA
	Data	Data	F0	AA	AA	AA	AA	AA	AA	AA	AA
2nd Bus Cyc	Addr			2AA	555	2AA	555	2AA	555	2AA	555
	Data			55	55	55	55	55	55	55	55
3rd Bus Cyc	Addr			555	AAA	555	AAA	555	AAA	555	AAA
	Data			90	90	90	90	90	90	90	90
4th Bus Cyc	Addr			X00	X00	X01	X02	X03	X06	(Sector) X02	(Sector) X04
	Data			C2H	C2H	ID1	ID1	98/18 (H) 88/08 (L)	98/18 (H) 88/08 (L)	00/01	00/01
5th Bus Cyc	Addr					X0E	X1C				
	Data					ID2	ID2				
6th Bus Cyc	Addr					X0F	X1E				
	Data					ID3	ID3				

Command	Hex	Enter Security Sector Region Enable		Exit Security Sector		Program		Chip Erase		Sector Erase		CFI Read		Erase Suspend	Erase Resume
		Word	Byte	Word	Byte	Word	Byte	Word	Byte	Word	Byte	Word	Byte	Byte/Word	Byte/Word
1st Bus Cyc	Addr	555	AAA	555	AAA	555	AAA	555	AAA	555	AAA	55	AA	XXX	XXX
	Data	AA	AA	AA	AA	AA	AA	AA	AA	AA	AA	98	98	B0	30
2nd Bus Cyc	Addr	2AA	555	2AA	555	2AA	555	2AA	555	2AA	555				
	Data	55	55	55	55	55	55	55	55	55	55				
3rd Bus Cyc	Addr	555	AAA	555	AAA	555	AAA	555	AAA	555	AAA				
	Data	88	88	90	90	A0	A0	80	80	80	80				
4th Bus Cyc	Addr			XXX	XXX	Addr	Addr	555	AAA	555	AAA				
	Data			00	00	Data	Data	AA	AA	AA	AA				
5th Bus Cyc	Addr							2AA	555	2AA	555				
	Data							55	55	55	55				
6th Bus Cyc	Addr							555	AAA	Sector	Sector				
	Data							10	10	30	30				

Notes:

Device ID	ID1		ID2		ID3	
	Word	Byte	Word	Byte	Word	Byte
MX29LA641DH	227E	7E	2213	13	2201	01
MX29LA641DL	227E	7E	2213	13	2200	00

RESET

In the following situations, executing reset command will reset device back to read array mode:

- Among erase command sequence (before the full command set is completed)
- Sector erase time-out period
- Erase fail (while Q5 is high)
- Among program command sequence (before the full command set is completed, erase-suspended program included)
- Program fail (while Q5 is high, and erase-suspended program fail is included)
- Read silicon ID mode
- Sector protect verify
- CFI mode

While device is at the status of program fail or erase fail (Q5 is high), user must issue reset command to reset device back to read array mode. While the device is in read silicon ID mode, sector protect verify or CFI mode, user must issue reset command to reset device back to read array mode.

When the device is in the progress of programming (not program fail) or erasing (not erase fail), device will ignore reset command.

AUTOMATIC SELECT COMMAND SEQUENCE

Automatic Select mode is used to access the manufacturer ID, device ID and to verify whether or not secured silicon is locked and whether or not a sector is protected. The automatic select mode has four command cycles. The first two are unlock cycles, and followed by a specific command. The fourth cycle is a normal read cycle, and user can read at any address any number of times without entering another command sequence. The reset command is necessary to exit the Automatic Select mode and back to read array. The following table shows the identification code with corresponding address.

Identifier Code	Word/Byte Mode	Address	Data (Hex)	Representation
Manufacturer ID	Word	X00	C2	
	Byte	X00	C2	
Device ID, cycle 1	Word	X01	227E	
	Byte	X02	7E	
Device ID, cycle 2	Word	X0E	2213	
	Byte	X1C	13	
Device ID, cycle 3	Word	X0F	2201/2200	29LA641D H/L
	Byte	X1E	01/00	
Secured Silicon	Word	X03	98/18 (H) 88/08 (L)	Factory locked/unlocked
	Byte	X06	98/18 (H) 88/08 (L)	Factory locked/unlocked
Sector Protect Verify	Word	(Sector address) X 02	00/01	Unprotected/protected
	Byte	(Sector address) X 04	00/01	Unprotected/protected

There is an alternative method to that shown in Table 2, which is intended for EPROM programmers and requires V_{hh} on address bit A9.

AUTOMATIC PROGRAMMING

The MX29LA641D H/L can provide the user program function by the form of Byte-Mode or Word-Mode. As long as the users enter the right cycle defined in the Table.3 (including 2 unlock cycles and A0H), any data user inputs will automatically be programmed into the array.

Once the program function is executed, the internal write state controller will automatically execute the algorithms and timings necessary for program and verification, which includes generating suitable program pulse, verifying whether the threshold voltage of the programmed cell is high enough and repeating the program pulse if any of the cells does not pass verification. Meanwhile, the internal control will prohibit the programming to cells that pass verification while the other cells fail in verification in order to avoid over-programming. With the internal write state controller, the device requires the user to write the program command and data only.

Programming will only change the bit status from "1" to "0". That is to say, it is impossible to convert the bit status from "0" to "1" by programming. Meanwhile, the internal write verification only detects the errors of the "1" that is not successfully programmed to "0".

Any command written to the device during programming will be ignored except hardware reset, which will terminate the program operation after a period of time no more than Tready. When the embedded program algorithm is complete or the program operation is terminated by hardware reset, the device will return to the reading array data mode.

The typical chip program time at room temperature of the MX29LA641D H/L is less than 45 seconds.

When the embedded program operation is on going, user can confirm if the embedded operation is finished or not by the following methods:

Status	Q7	Q6	Q5	RY/BY#*2
In progress*1	Q7#	Toggling	0	0
Finished	Q7	Stop toggling	0	1
Exceed time limit	Q7#	Toggling	1	0

*1: The status "in progress" means both program mode and erase-suspended program mode.

*2: RY/BY# is an open drain output pin and should be weakly connected to VDD through a pull-up resistor.

*3: When an attempt is made to program a protected sector, Q7 will output its complement data or Q6 continues to toggle for about 1us or less and the device returns to read array state without programming the data in the protected sector.

CHIP ERASE

Chip Erase is to erase all the data with "1" and "0" as all "1". It needs 6 cycles to write the action in, and the first two cycles are "unlock" cycles, the third one is a configuration cycle, the fourth and fifth are also "unlock" cycles, and the sixth cycle is the chip erase operation.

During chip erasing, all the commands will not be accepted except hardware reset or the working voltage is too low that chip erase will be interrupted. After Chip Erase, the chip will return to the state of Read Array.

When the embedded chip erase operation is on going, user can confirm if the embedded operation is finished or not by the following methods:

Status	Q7	Q6	Q5	Q2	RY/BY#
In progress	0	Toggling	0	Toggling	0
Finished	1	Stop toggling	0	1	1
Exceed time limit	0	Toggling	1	Toggling	0

SECTOR ERASE

Sector Erase is to erase all the data in a sector with "1" and "0" as all "1". It requires six command cycles to issue. The first two cycles are "unlock cycles", the third one is a configuration cycle, the fourth and fifth are also "unlock cycles" and the sixth cycle is the sector erase command. After the sector erase command sequence is issued, there is a time-out period of 50us counted internally. During the time-out period, additional sector address and sector erase command can be written multiply. Once user enters another sector erase command, the time-out period of 50us is recounted. If user enters any command other than sector erase or erase suspend during time-out period, the erase command would be aborted and the device is reset to read array condition. The number of sectors could be from one sector to all sectors. After time-out period passing by, additional erase command is not accepted and erase embedded operation begins.

During sector erasing, all commands will not be accepted except hardware reset and erase suspend and user can check the status as chip erase.

When the embedded erase operation is on going, user can confirm if the embedded operation is finished or not by the following methods:

Status	Q7	Q6	Q5	Q3	Q2	RY/BY#*2
Time-out period	0	Toggling	0	0	Toggling	0
In progress	0	Toggling	0	1	Toggling	0
Finished	1	Stop toggling	0	1	1	1
Exceed time limit	0	Toggling	1	1	Toggling	0

*1: The status Q3 is the time-out period indicator. When Q3=0, the device is in time-out period and is acceptable to another sector address to be erased. When Q3=1, the device is in erase operation and only erase suspend is valid.

*2: RY/BY# is open drain output pin and should be weakly connected to VDD through a pull-up resistor.

*3: When an attempt is made to erase a protected sector, Q7 will output its complement data or Q6 continues to toggle for 100us or less and the device returned to read array status without erasing the data in the protected sector.

SECTOR ERASE SUSPEND

During sector erasure, sector erase suspend is the only valid command. If user issue erase suspend command in the time-out period of sector erasure, device time-out period will be over immediately and the device will go back to erase-suspended read array mode. If user issue erase suspend command during the sector erase is being operated, device will suspend the ongoing erase operation, and after the Tready1 ($\leq 20\mu s$) suspend finishes and the device will enter erase-suspended read array mode. User can judge if the device has finished erase suspend through Q6, Q7, and RY/BY#.

After device has entered erase-suspended read array mode, user can read other sectors not at erase suspend by the speed of Taa; while reading the sector in erase-suspend mode, device will output its status. User can use Q6 and Q2 to judge the sector is erasing or the erase is suspended.

Status	Q7	Q6	Q5	Q3	Q2	RY/BY#
Erase suspend read in erase suspended sector	1	No toggle	0	N/A	Toggle	1
Erase suspend read in non-erase suspended sector	Data	Data	Data	Data	Data	1
Erase suspend program in non-erase suspended sector	Q7#	Toggle	0	N/A	N/A	0

When the device has suspended erasing, user can execute the command sets except sector erase and chip erase, such as read silicon ID, sector protect verify, program, CFI query and erase resume.

SECTOR ERASE RESUME

Sector erase resume command is valid only when the device is in erase suspend state. After erase resume, user can issue another erase suspend command, but there should be a 4ms interval between erase resume and the next erase suspend. If user issue infinite suspend-resume loop, or suspend-resume exceeds 1024 times, the time for erasing will increase.

QUERY COMMAND AND COMMON FLASH INTERFACE (CFI) MODE

MX29LA641D H/L features CFI mode. Host system can retrieve the operating characteristics, structure and vendor-specified information such as identifying information, memory size, byte/word configuration, operating voltages and timing information of this device by CFI mode. The device enters the CFI Query mode when the system writes the CFI Query command "98H" to address "55H" any time the device is ready to read array data. The system can read CFI information at the addresses given in Table 4. A reset command is required to exit CFI mode and go back to ready array mode or erase suspend mode. The system can write the CFI Query command only when the device is in read mode, erase suspend, standby mode or automatic select mode.

Table 4-1. CFI mode: Identification Data Values
(All values in these tables are in hexadecimal)

Description	Address (h)	Address (h)	Data (h)
	(Word Mode)	(Byte Mode)	
Query-unique ASCII string "QRY"	10	20	0051
	11	22	0052
	12	24	0059
Primary vendor command set and control interface ID code	13	26	0002
	14	28	0000
Address for primary algorithm extended query table	15	2A	0040
	16	2C	0000
Alternate vendor command set and control interface ID code	17	2E	0000
	18	30	0000
Address for alternate algorithm extended query table	19	32	0000
	1A	34	0000

Table 4-2. CFI Mode: System Interface Data Values

Description	Address (h)	Address (h)	Data (h)
	(Word Mode)	(Byte Mode)	
Vcc supply minimum program/erase voltage	1B	36	0027
Vcc supply maximum program/erase voltage	1C	38	0036
VPP supply minimum program/erase voltage	1D	3A	0000
VPP supply maximum program/erase voltage	1E	3C	0000
Typical timeout per single word/byte write, 2 ⁿ us	1F	3E	0004
Typical timeout for maximum-size buffer write, 2 ⁿ us	20	40	0000
Typical timeout per individual block erase, 2 ⁿ ms	21	42	000A
Typical timeout for full chip erase, 2 ⁿ ms	22	44	0000
Maximum timeout for word/byte write, 2 ⁿ times typical	23	46	0005
Maximum timeout for buffer write, 2 ⁿ times typical	24	48	0000
Maximum timeout per individual block erase, 2 ⁿ times typical	25	4A	0004
Maximum timeout for chip erase, 2 ⁿ times typical	26	4C	0000

Table 4-3. CFI Mode: Device Geometry Data Values

Description	Address (h)	Address (h)	Data (h)
	(Word Mode)	(Byte Mode)	
Device size = 2 ⁿ in number of bytes	27	4E	0017
Flash device interface description (02=asynchronous x8/x16)	28	50	0002
	29	52	0000
Maximum number of bytes in buffer write = 2 ⁿ (not support)	2A	54	0000
	2B	56	0000
Number of erase regions within device	2C	58	0001
Index for Erase Bank Area 1	2D	5A	007F
[2E,2D] = # of same-size sectors in region 1-1	2E	5C	0000
[30, 2F] = sector size in multiples of 256-bytes	2F	5E	0000
	30	60	0001
Index for Erase Bank Area 2	31	62	0000
	32	64	0000
	33	66	0000
	34	68	0000
Index for Erase Bank Area 3	35	6A	0000
	36	6C	0000
	37	6E	0000
	38	70	0000
Index for Erase Bank Area 4	39	72	0000
	3A	74	0000
	3B	76	0000
	3C	78	0000

Table 4-4. CFI Mode: Primary Vendor-Specific Extended Query Data Values

Description	Address (h)	Address (h)	Data (h)
	(Word Mode)	(Byte Mode)	
Query - Primary extended table, unique ASCII string, PRI	40	80	0050
	41	82	0052
	42	84	0049
Major version number, ASCII	43	86	0031
Minor version number, ASCII	44	88	0033
Unlock recognizes address (0= recognize, 1= don't recognize)	45	8A	0000
Erase suspend (2= to both read and program)	46	8C	0002
Sector protect (N= # of sectors/group)	47	8E	0004
Temporary sector unprotect (1=supported)	48	90	0001
Sector protect/Chip unprotect scheme	49	92	0004
Simultaneous R/W operation (0=not supported)	4A	94	0000
Burst mode (0=not supported)	4B	96	0000
Page mode (0=not supported)	4C	98	0000
Minimum acceleration supply (0= not supported), [D7:D4] for volt, [D3:D0] for 100mV	4D	9A	0095
Maximum acceleration supply (0= not supported), [D7:D4] for volt, [D3:D0] for 100mV	4E	9C	00A5
Low/High boot block indicator	4F	9E	0004/
04h=Low boot device,			0005
05h=High boot device			

ABSOLUTE MAXIMUM STRESS RATINGS

Surrounding Temperature with Bias	-65°C to +125°C
Storage Temperature	-65°C to +150°C
Voltage Range	
Vcc	-0.5 V to +4.0 V
RESET#, A9, ACC and OE#	-0.5 V to +10.5 V
The other pins.	-0.5 V to Vcc +0.5 V
Output Short Circuit Current (less than one second)200 mA

Note:

- 1. Minimum voltage may undershoot to -2V during transition and for less than 20ns during transitions.
- 2. Maximum voltage may overshoot to Vcc+2V during transition and for less than 20ns during transitions.

OPERATING TEMPERATURE AND VOLTAGE

Commercial (C) Grade

Surrounding Temperature (T_A)..... 0° C to +70° C

Industrial (I) Grade

Surrounding Temperature (T_A)..... -40° C to +85° C

Vcc Supply Voltages

Vcc range..... +2.7 V to 3.6 V

DC CHARACTERISTICS

Symbol	Description	Min	Typ	Max	Remark
Iilk	Input Leak			± 1.0uA	
Iilk9	A9 Leak			35uA	A9=10V
Iolk	Output Leak			± 1.0uA	
Icr1	Read Current(5MHz)		9mA	16mA	CE#=Vil, OE#=Vih
Icr2	Read Current(1MHz)		2mA	4mA	CE#=Vil, OE#=Vih
Icw	Write Current		26mA	30mA	CE#=Vil, OE#=Vih, WE#=Vil
I _{sb}	Standby Current		5uA	15uA	V _{cc} =V _{cc max} , other pin disable
I _{sr}	Reset Current		5uA	15uA	V _{cc} =V _{ccmax} , Reset# enable, other pin disable
I _{sb} s	Sleep Mode Current		5uA	15uA	
Icp1	Accelerated Pgm Current, WP#/Acc pin(Word/Byte)		5mA	10mA	CE#=Vil, OE#=Vih,
Icp2	Accelerated Pgm Current, Vcc pin,(Word/Byte)		15mA	30mA	CE#=Vil, OE#=Vih,
Vil	Input Low Voltage	-0.5V		0.8V	
Vih	Input High Voltage	0.7xV _{cc}		V _{cc} +0.3V	
V _{hv}	Very High Voltage for hardware Protect/Unprotect/Auto Select/ Temporary Unprotect/ Accelerated Program	9.5V		10.5V	
V _{ol}	Output Low Voltage			0.45V	I _{ol} =4.0mA
V _{oh1}	Output High Voltage	0.85xV _{cc}			I _{oh1} =-2mA
V _{oh2}	Output High Voltage	V _{cc} -0.4V			I _{oh2} =-100uA
Vlko	Low Vcc Lock-out Voltage	2.3V		2.5V	

SWITCHING TEST CIRCUITS

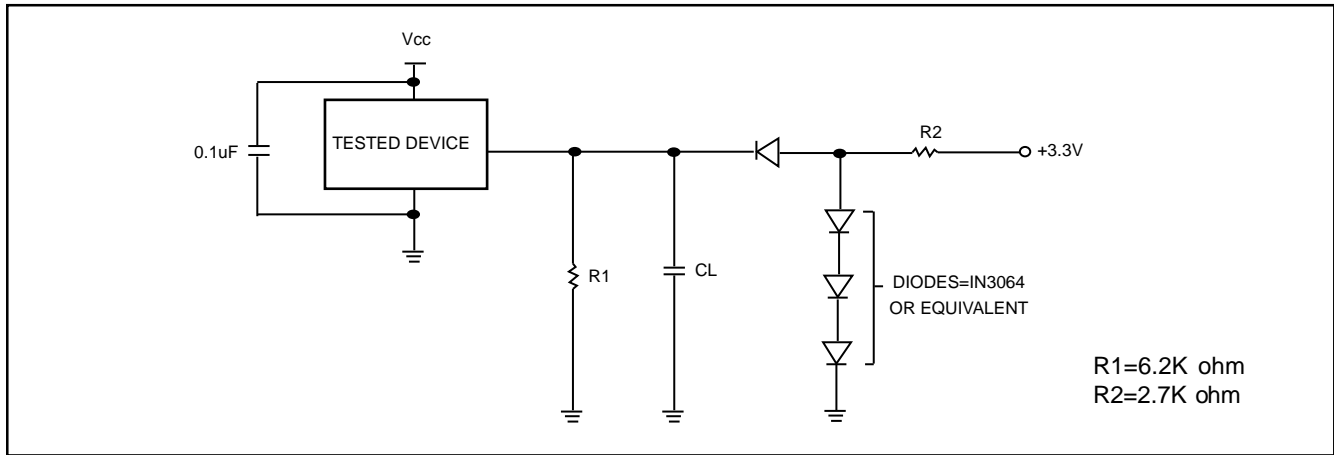

Test Condition
Output Load : 1 TTL gate
Output Load Capacitance, CL : 30pF
Rise/Fall Times : 5ns
In/Out reference levels : 1.5V
Input Pulse level : 0.0 ~ 3.0V

SWITCHING TEST WAVEFORMS

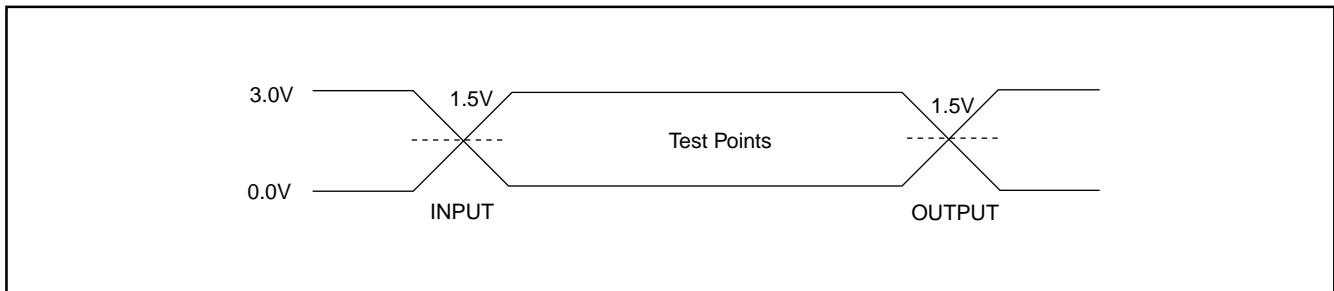

AC CHARACTERISTICS

Symbol	Description	Min	Typ	Max	Unit
Taa	Valid data output after address			90	ns
Tce	Valid data output after CEx low			90	ns
Toe	Valid data output after OE# low			30	ns
Tdf	Data output floating after OE# high			30	ns
Toh	Output hold time from the earliest rising edge of address, CEx, OE#	0			ns
Trc	Read period time	90			ns
Twc	Write period time	90			ns
Tcwc	Command write period time	90			ns
Tas	Address setup time	0			ns
Tah	Address hold time	45			ns
Tds	Data setup time	45			ns
Tdh	Data hold time	0			ns
Tvcs	Vcc setup time	100			us
Tcs	Chip enable Setup time	0			ns
Tch	Chip enable hold time	0			ns
Toes	Output enable setup time	0			ns
Toeh	Output enable hold time	Read	0		ns
Toeh		Toggle & Data# Polling	10		ns
Tws	WE# setup time	0			ns
Twh	WE# hold time	0			ns
Tcep	CEx pulse width	45			ns
Tceph	CEx pulse width high	30			ns
Twp	WE# pulse width	35			ns
Twph	WE# pulse width high	30			ns
Tbusy	Program/Erase active time by RY/BY#			90	ns
Tghwl	Read recover time before write	0			ns
Tghel	Read recover time before write	0			ns
Twhwh1	Program operation		11		us
Twhwh1	Acc Program operation(Word/Byte)		7		us
Twhwh2	Sector Erase Operation		0.7		sec
Tbal	Sector Add hold time			50	us

Figure 1. COMMAND WRITE OPERATION

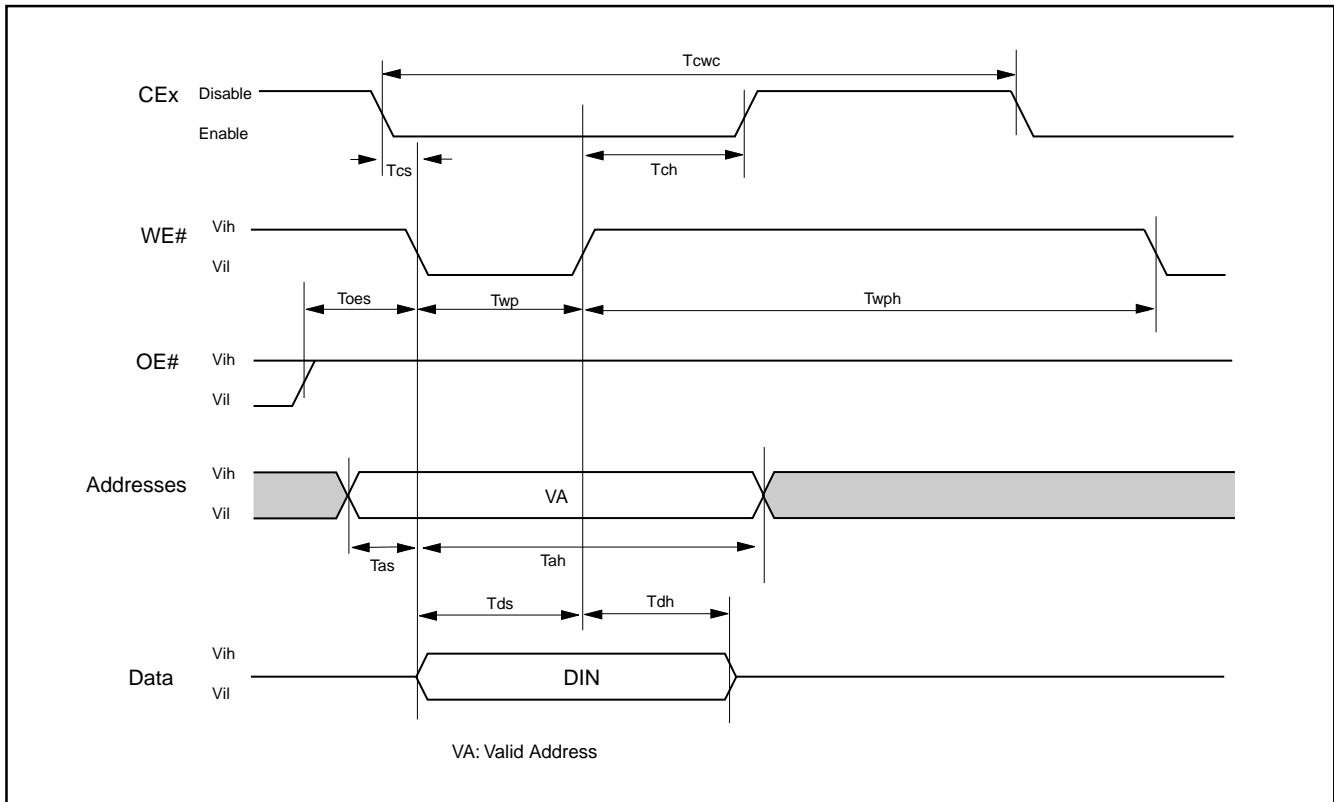

READ/RESET OPERATION

Figure 2. READ TIMING WAVEFORMS

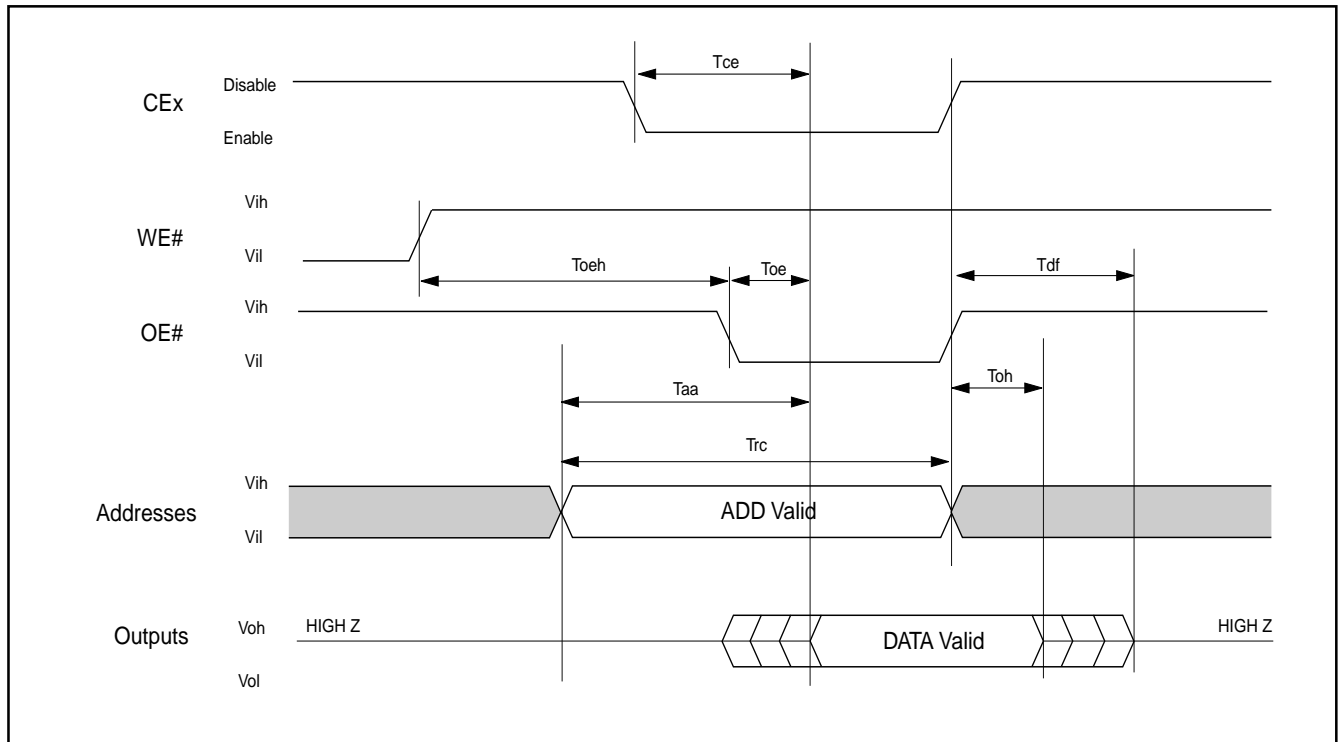

AC CHARACTERISTICS

Item	Description	Setup	Speed	Unit
Trp1	RESET# Pulse Width (During Automatic Algorithms)	MIN	10	us
Trp2	RESET# Pulse Width (NOT During Automatic Algorithms)	MIN	500	ns
Trh	RESET# High Time Before Read	MIN	50	ns
Trb1	RY/BY# Recovery Time (to CE#, OE# go low)	MIN	0	ns
Trb2	RY/BY# Recovery Time (to WE# go low)	MIN	50	ns
Tready1	RESET# PIN Low (During Automatic Algorithms) to Read or Write	MAX	20	us
Tready2	RESET# PIN Low (NOT During Automatic Algorithms) to Read or Write	MAX	500	ns

Figure 3. RESET# TIMING WAVEFORM

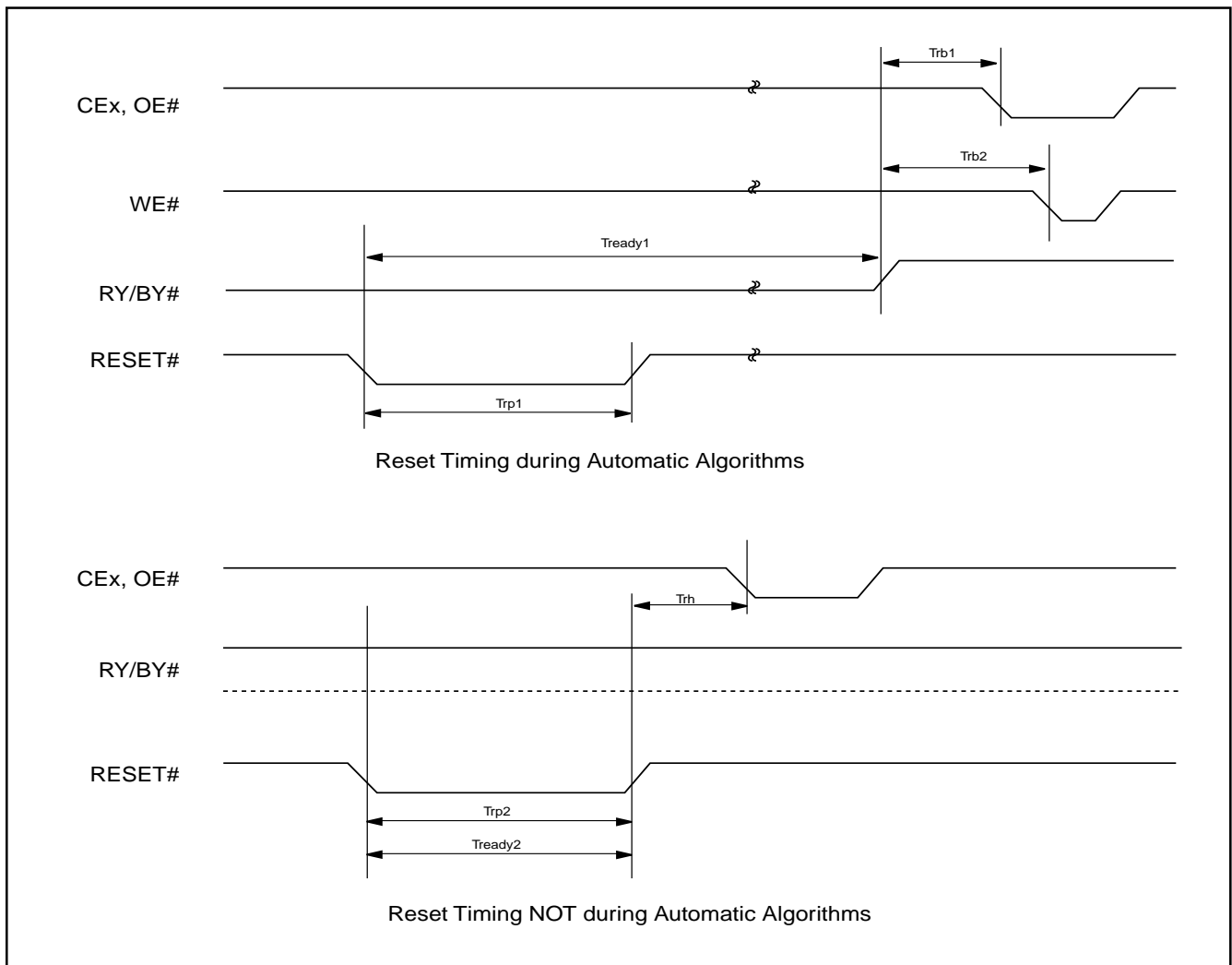

ERASE/PROGRAM OPERATION

Figure 4. AUTOMATIC CHIP ERASE TIMING WAVEFORM

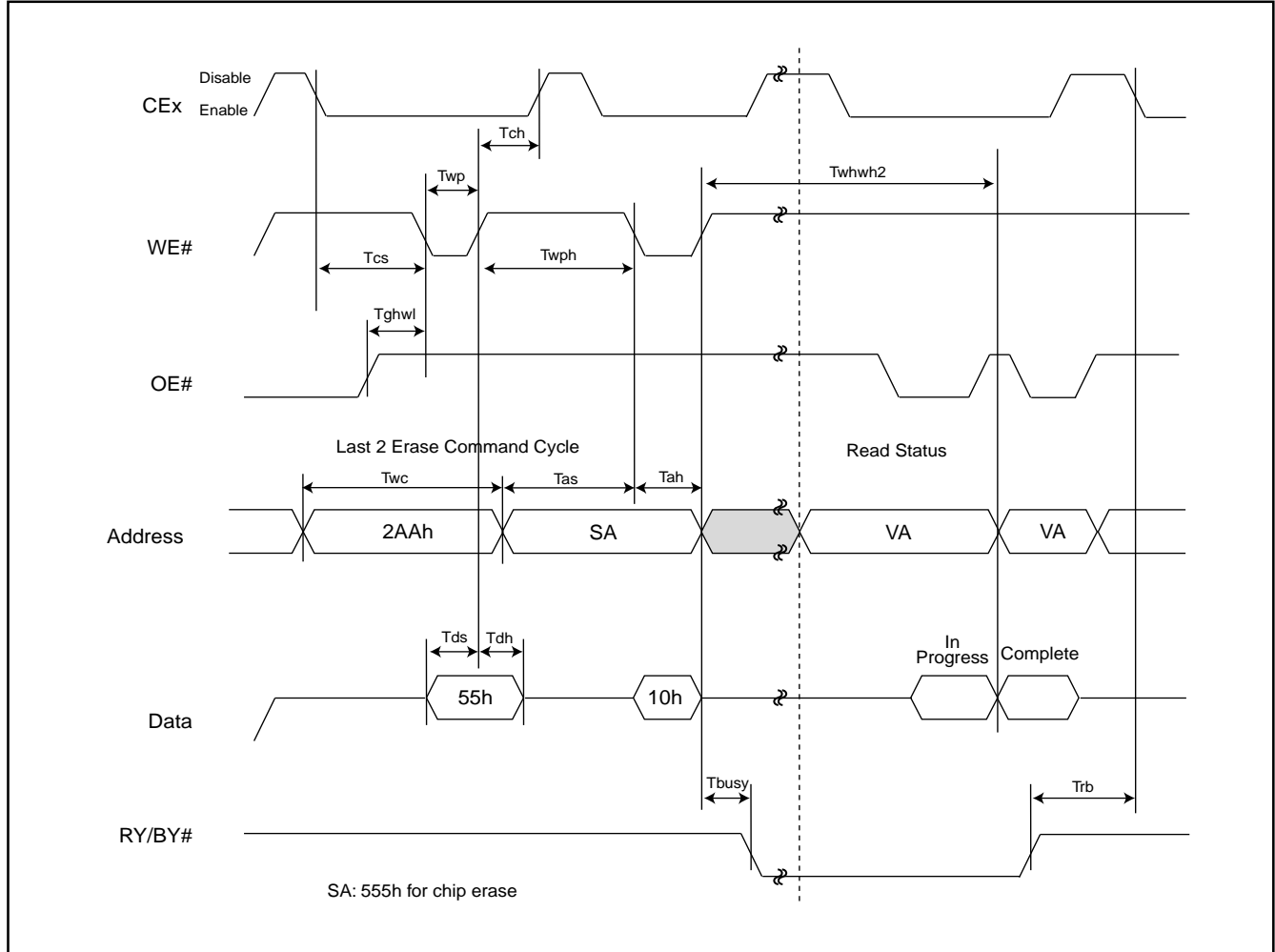

Figure 5. AUTOMATIC CHIP ERASE ALGORITHM FLOWCHART

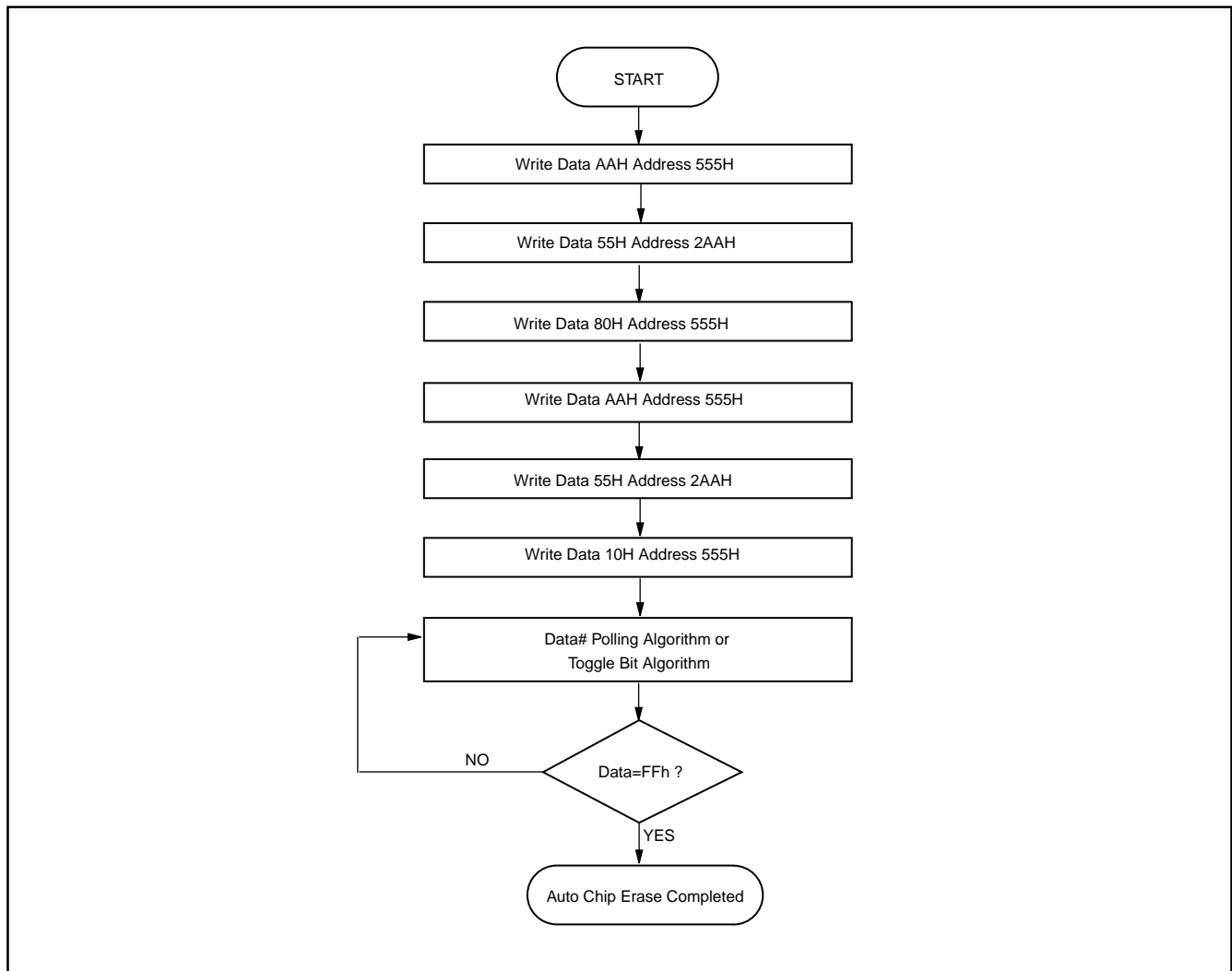

Figure 6. AUTOMATIC SECTOR ERASE TIMING WAVEFORM

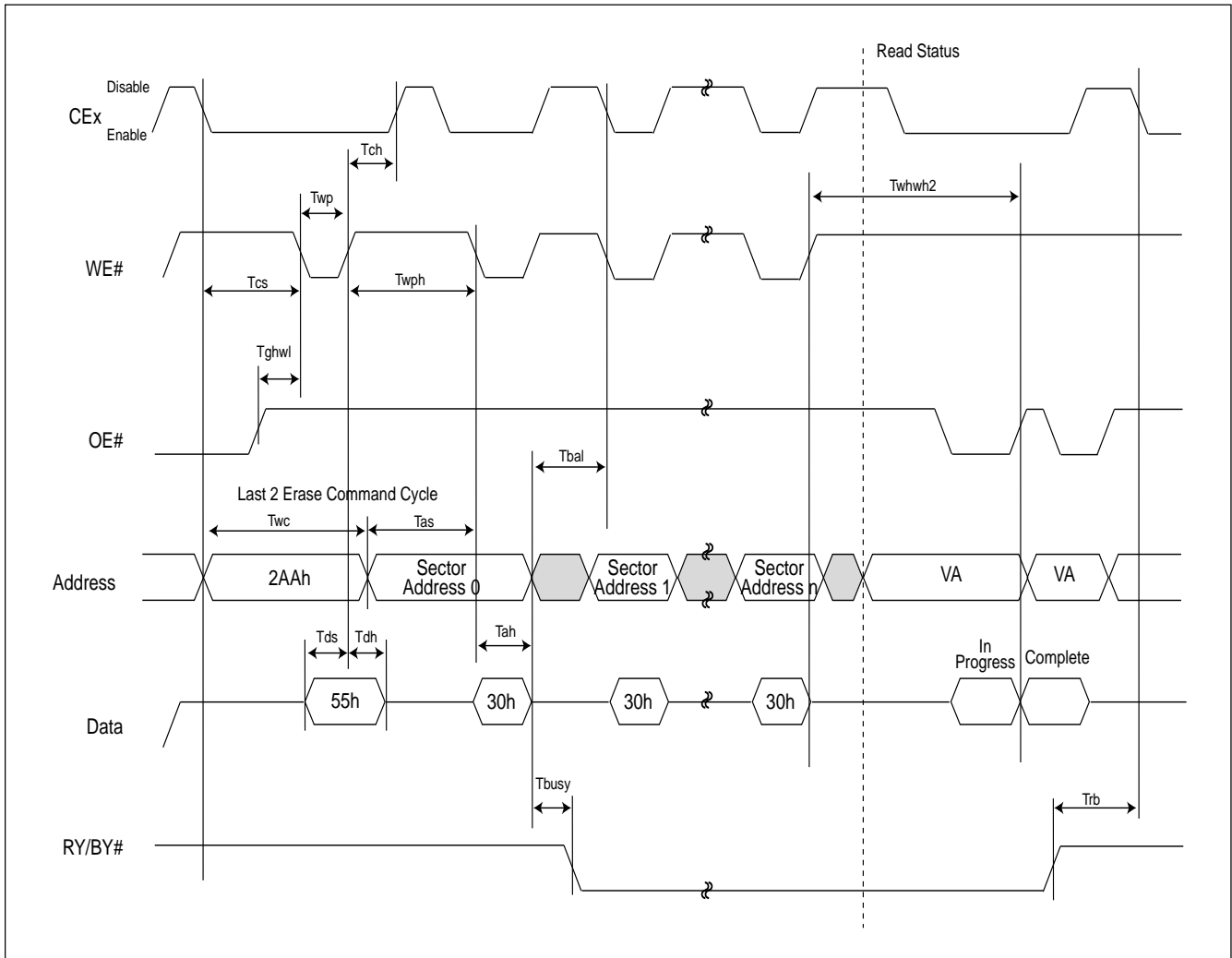

Figure 7. AUTOMATIC SECTOR ERASE ALGORITHM FLOWCHART

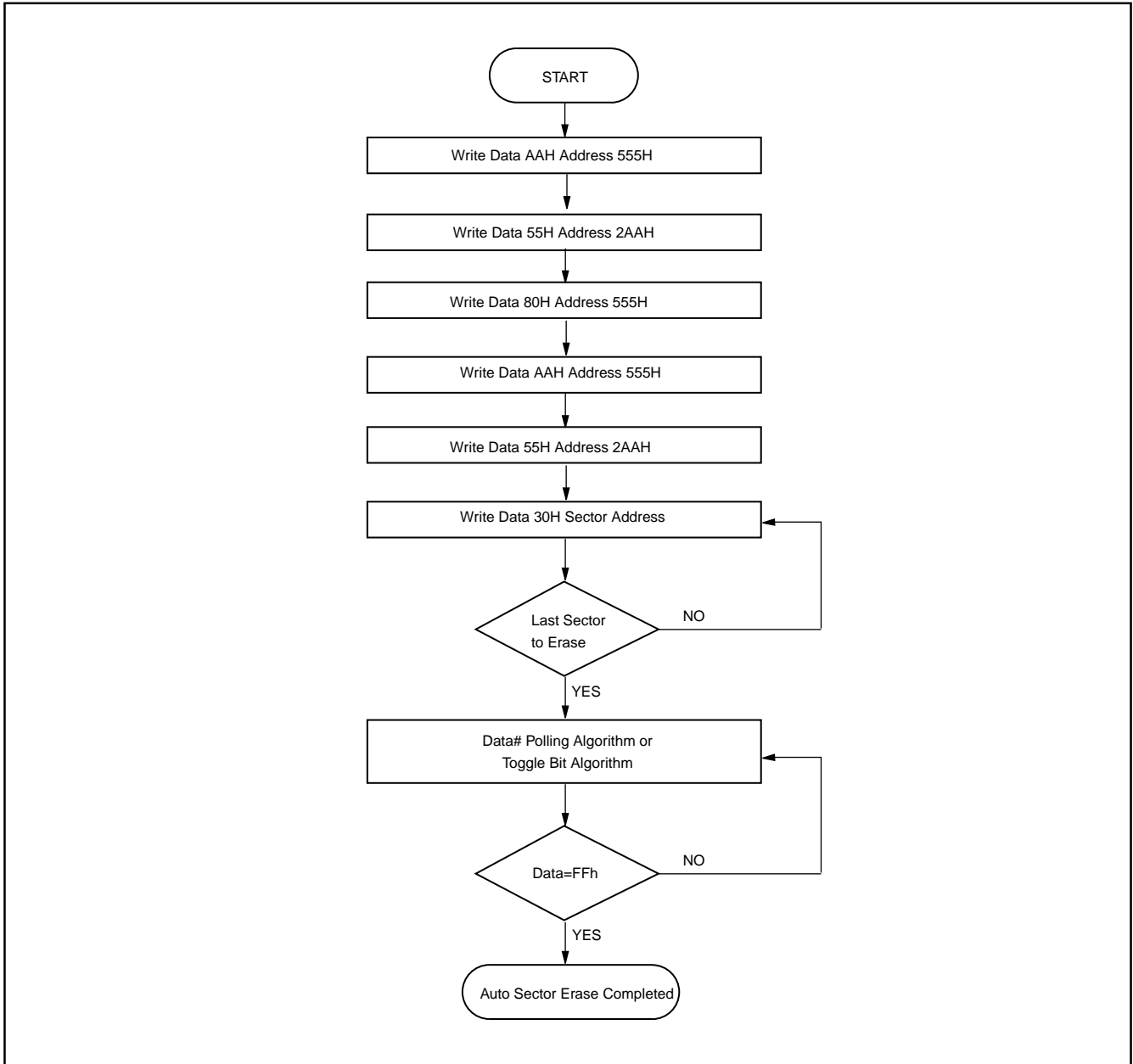

Figure 8. ERASE SUSPEND/RESUME FLOWCHART

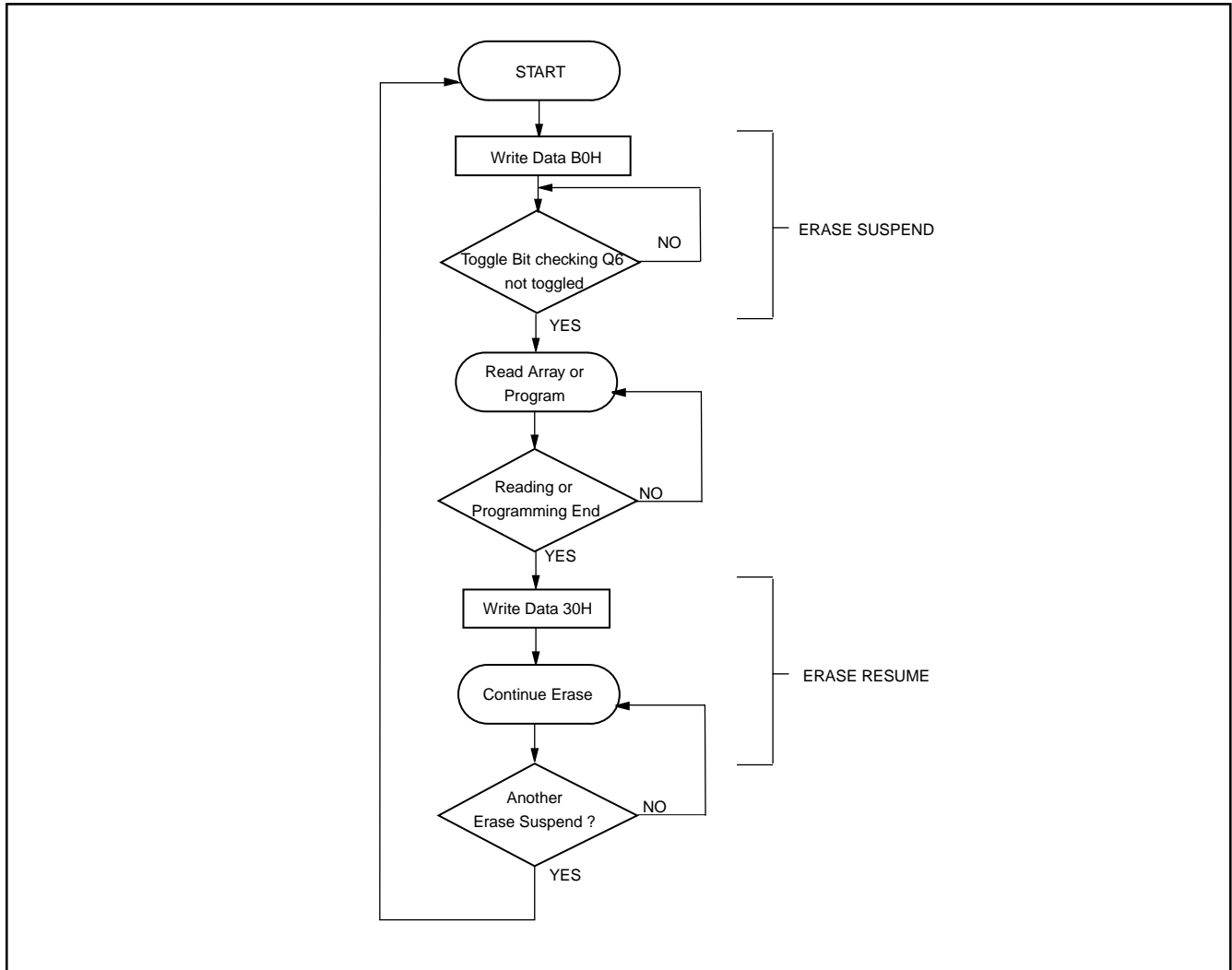

Figure 9. SECURED SILICON SECTOR PROTECTED ALGORITHMS FLOWCHART

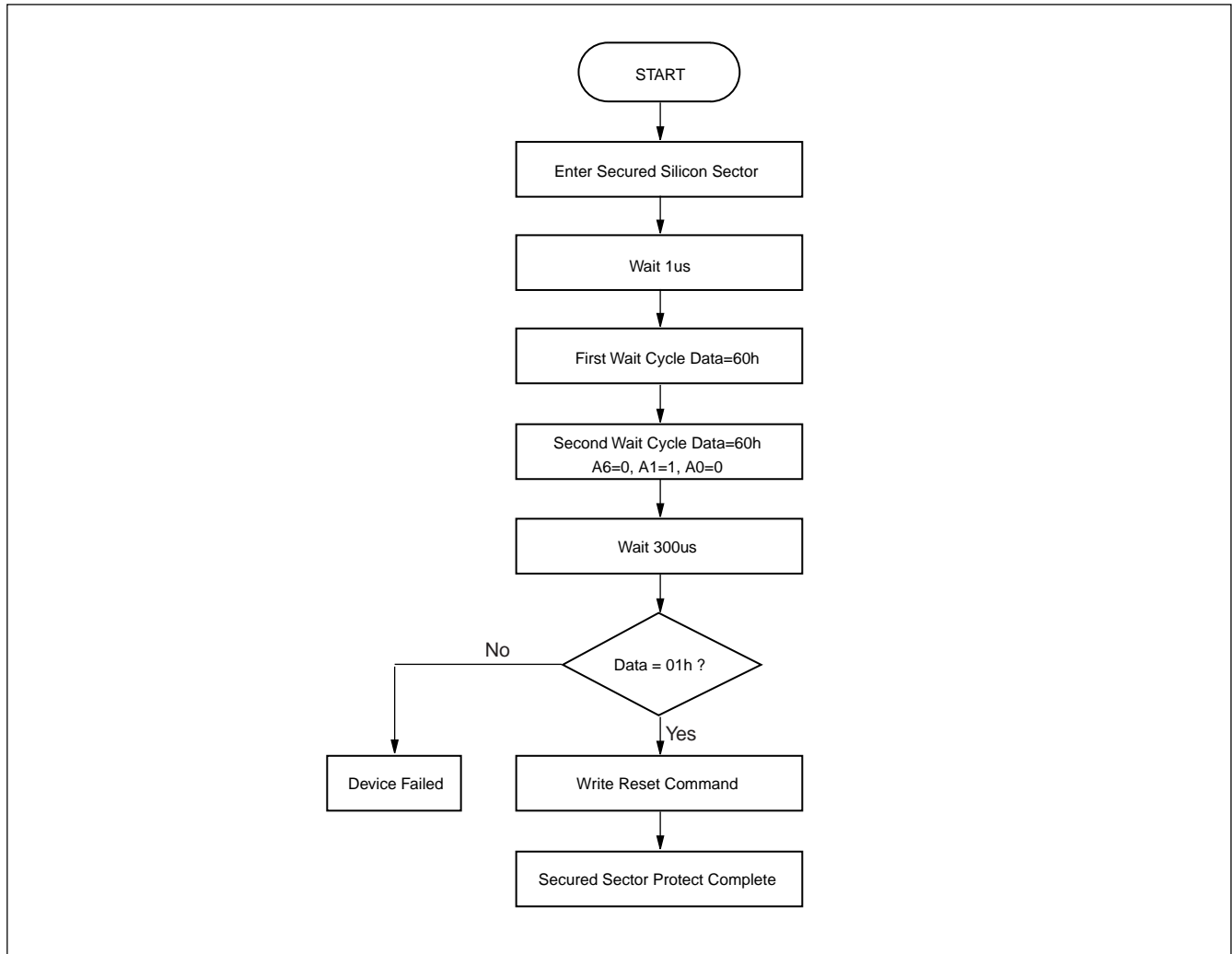

Figure 10. AUTOMATIC PROGRAM TIMING WAVEFORMS

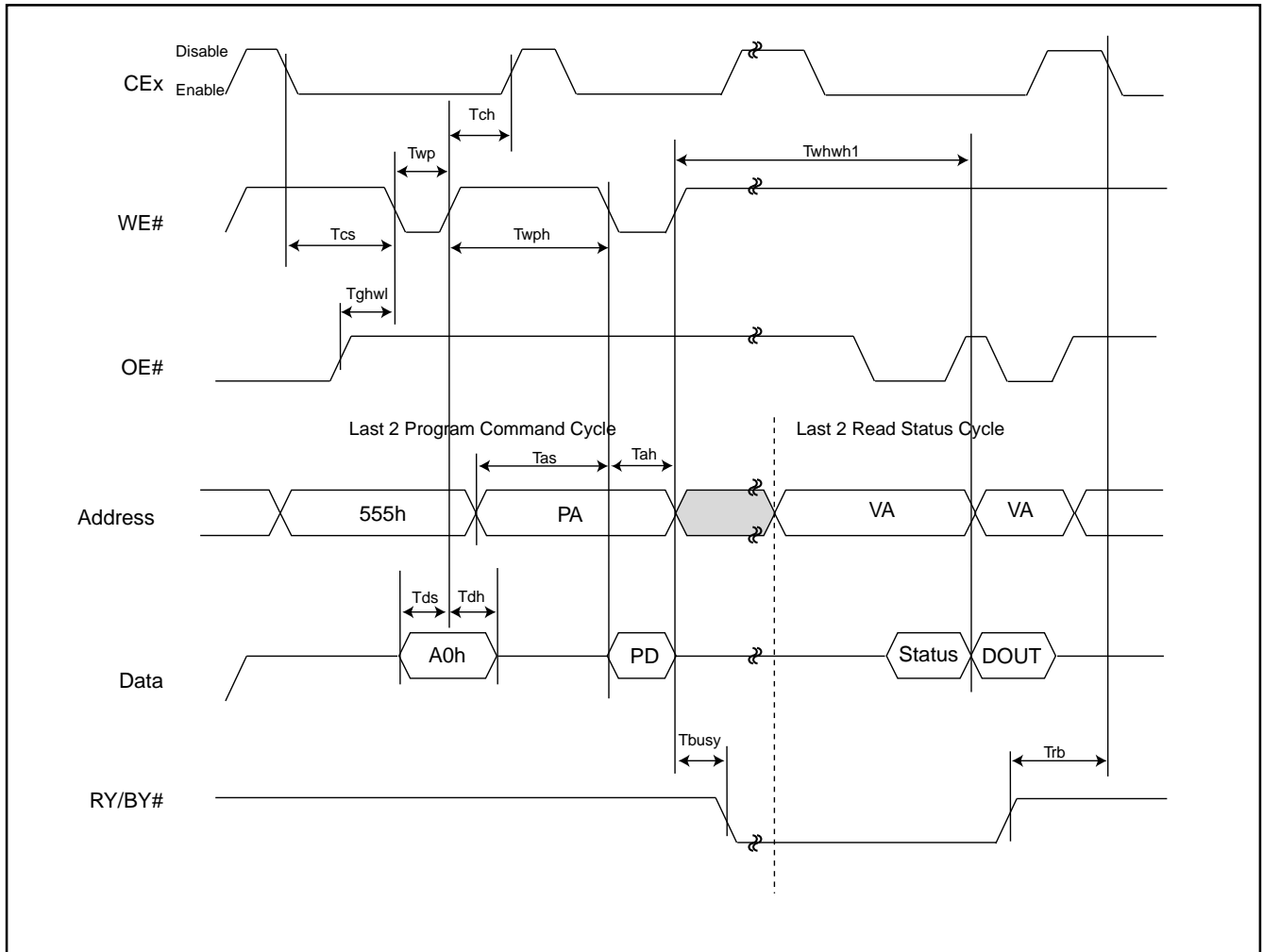

Figure 11. Accelerated Program Timing Diagram

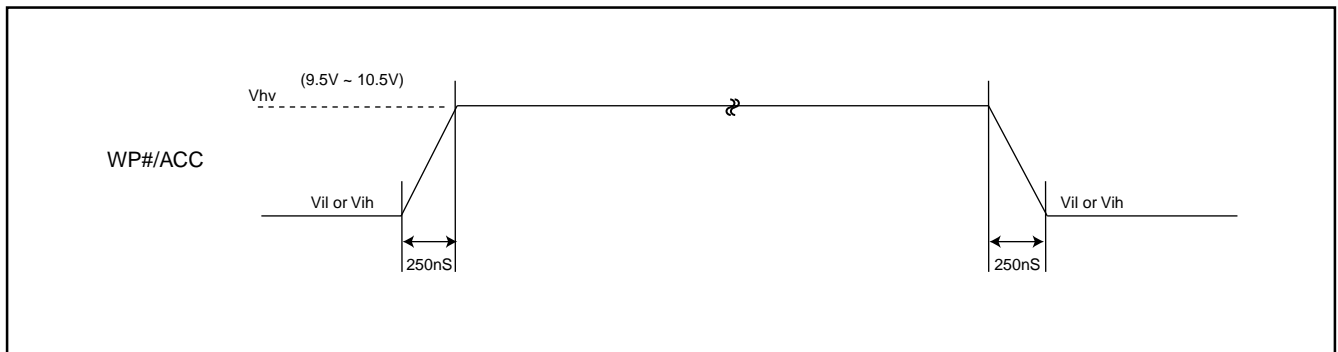

Figure 12. AUTOMATIC PROGRAMMING ALGORITHM FLOWCHART

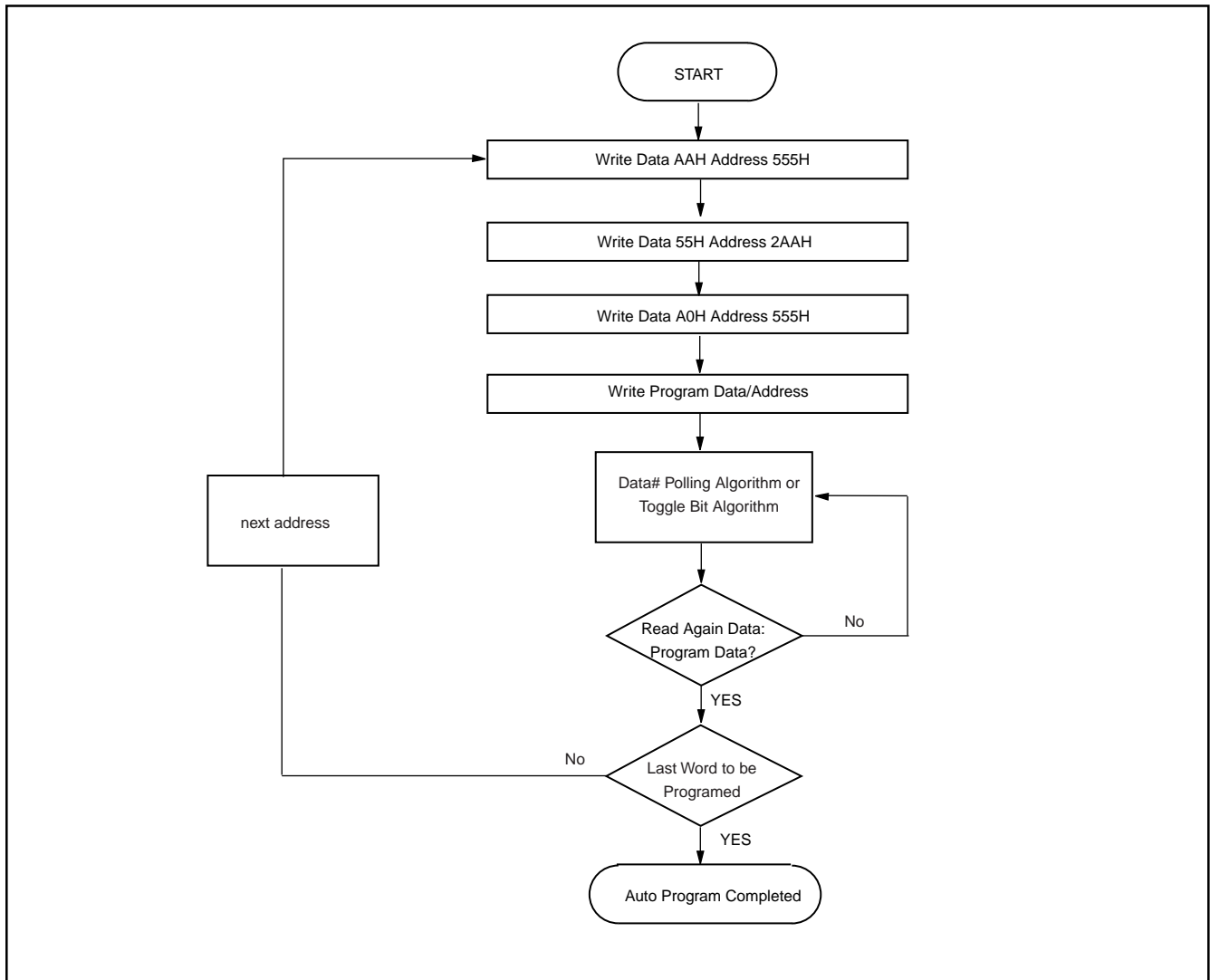
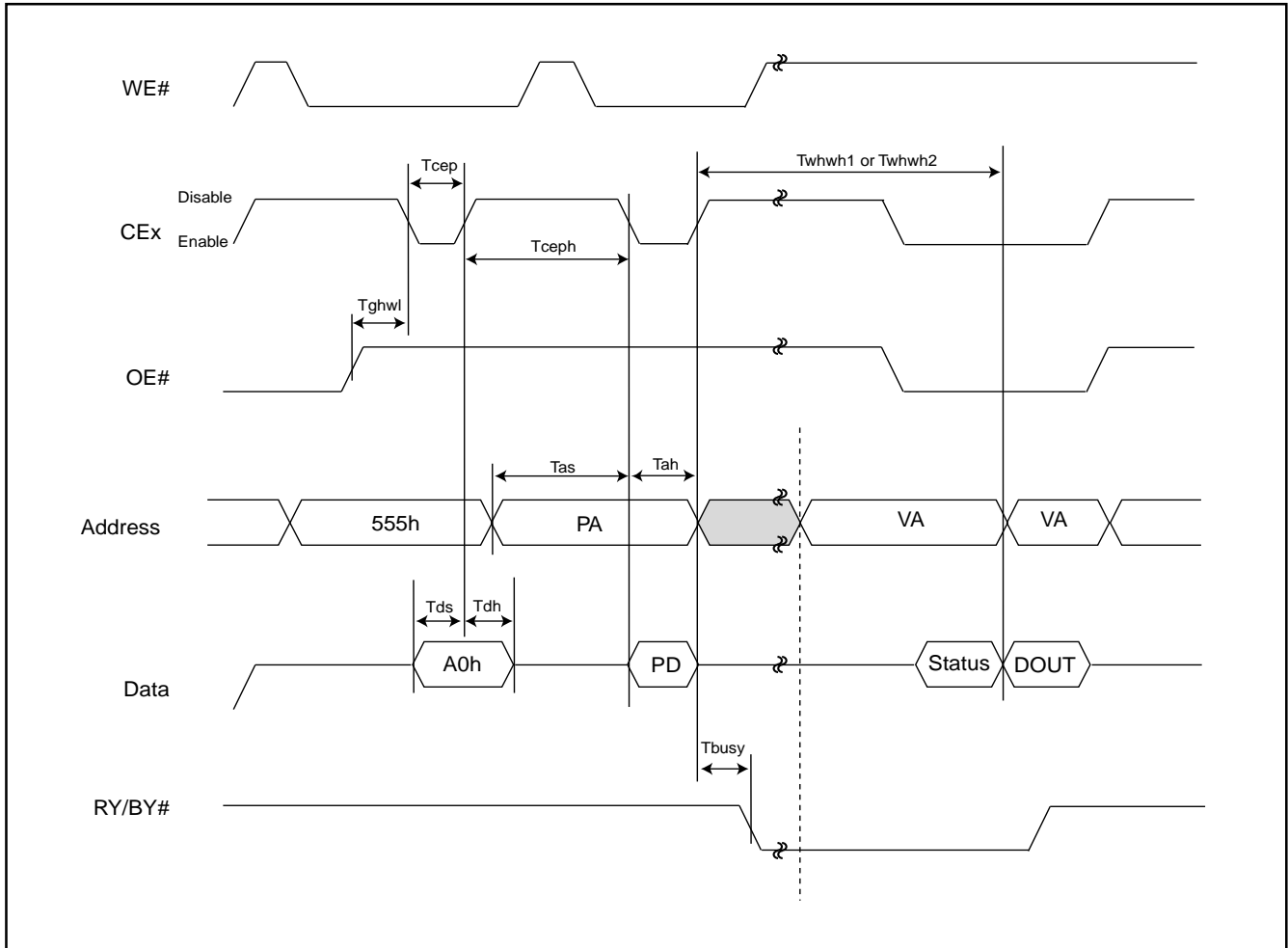

Figure 13. CEx CONTROLLED WRITE TIMING WAVEFORM



SECTOR PROTECT/CHIP UNPROTECT

Figure 14. SECTOR PROTECT/CHIP UNPROTECT WAVEFORM (RESET# Control)

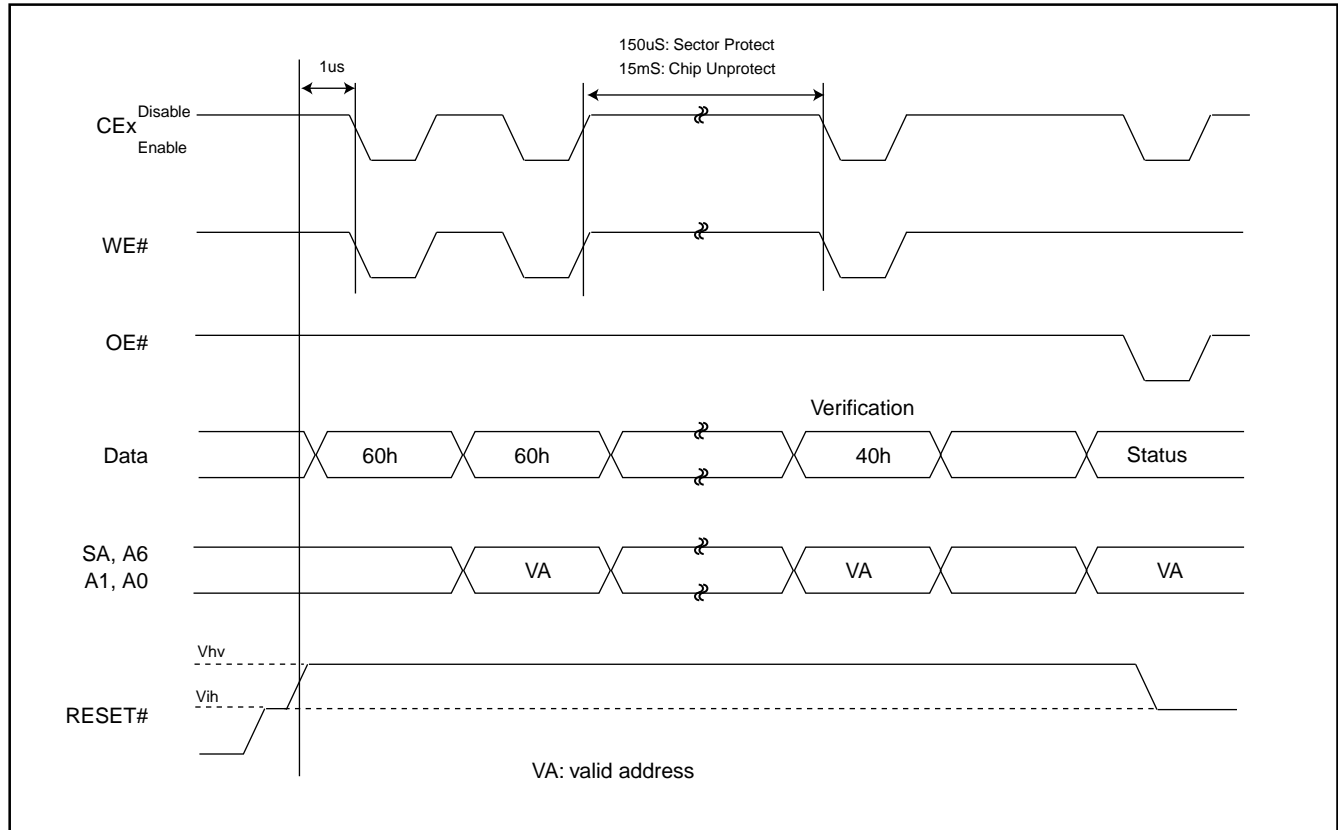

Figure 15-1. IN-SYSTEM SECTOR PROTECT WITH RESET# = Vhv

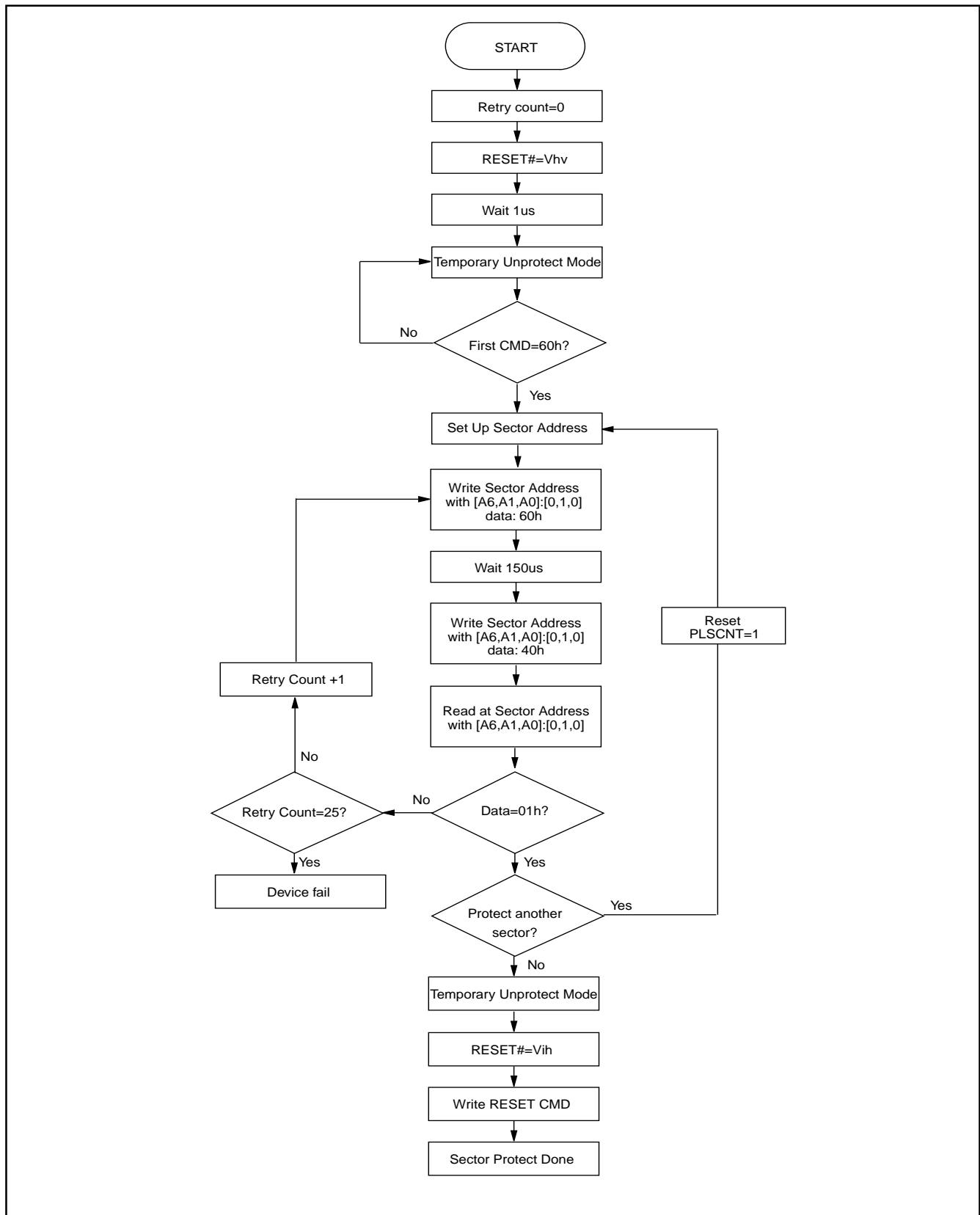
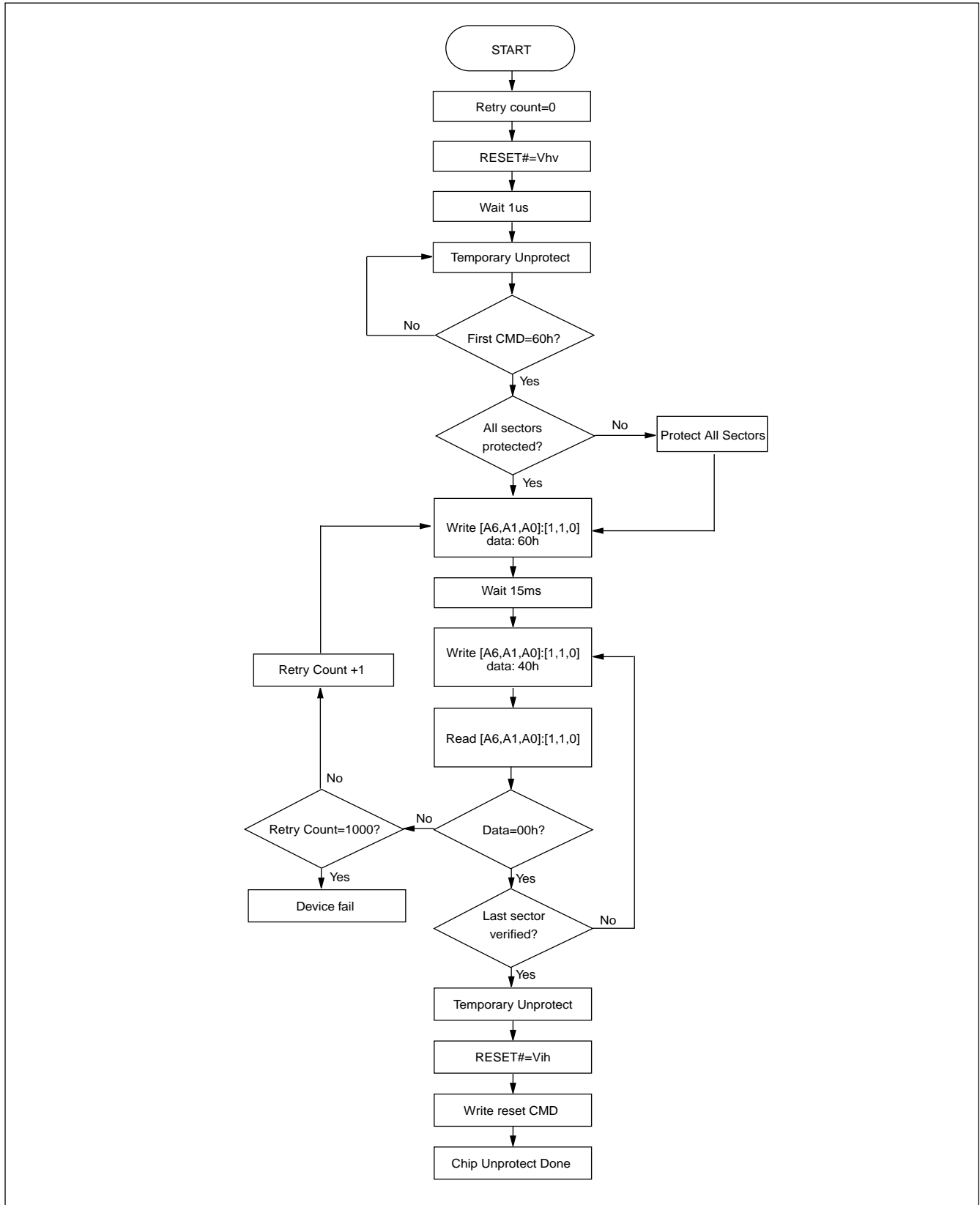

Figure 15-2. CHIP UNPROTECT ALGORITHMS WITH RESET# = Vhv



AC CHARACTERISTICS

Parameter	Description	Test Setup	All Speed Options	Unit
Tvlt	Voltage transition time	Min.	4	us
Twpp1	Write pulse width for sector protect	Min.	100	ns
Twpp2	Write pulse width for chip unprotect	Min.	100	ns
Toesp	OE# setup time to WE# active	Min.	4	us

Figure 16. SECTOR PROTECT TIMING WAVEFORM (A9, OE# Control)

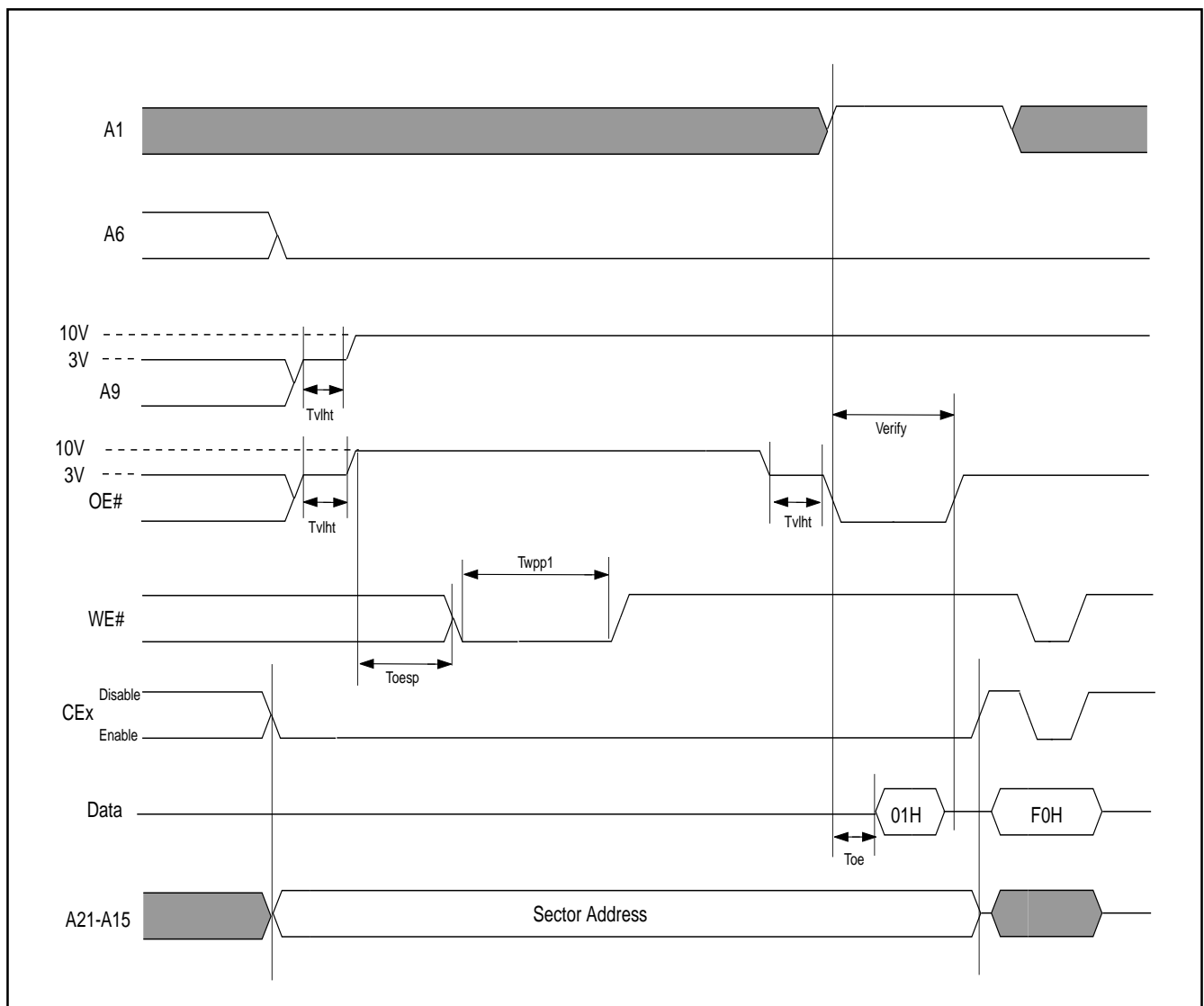

Figure 17. SECTOR PROTECTION ALGORITHM (A9, OE# Control)

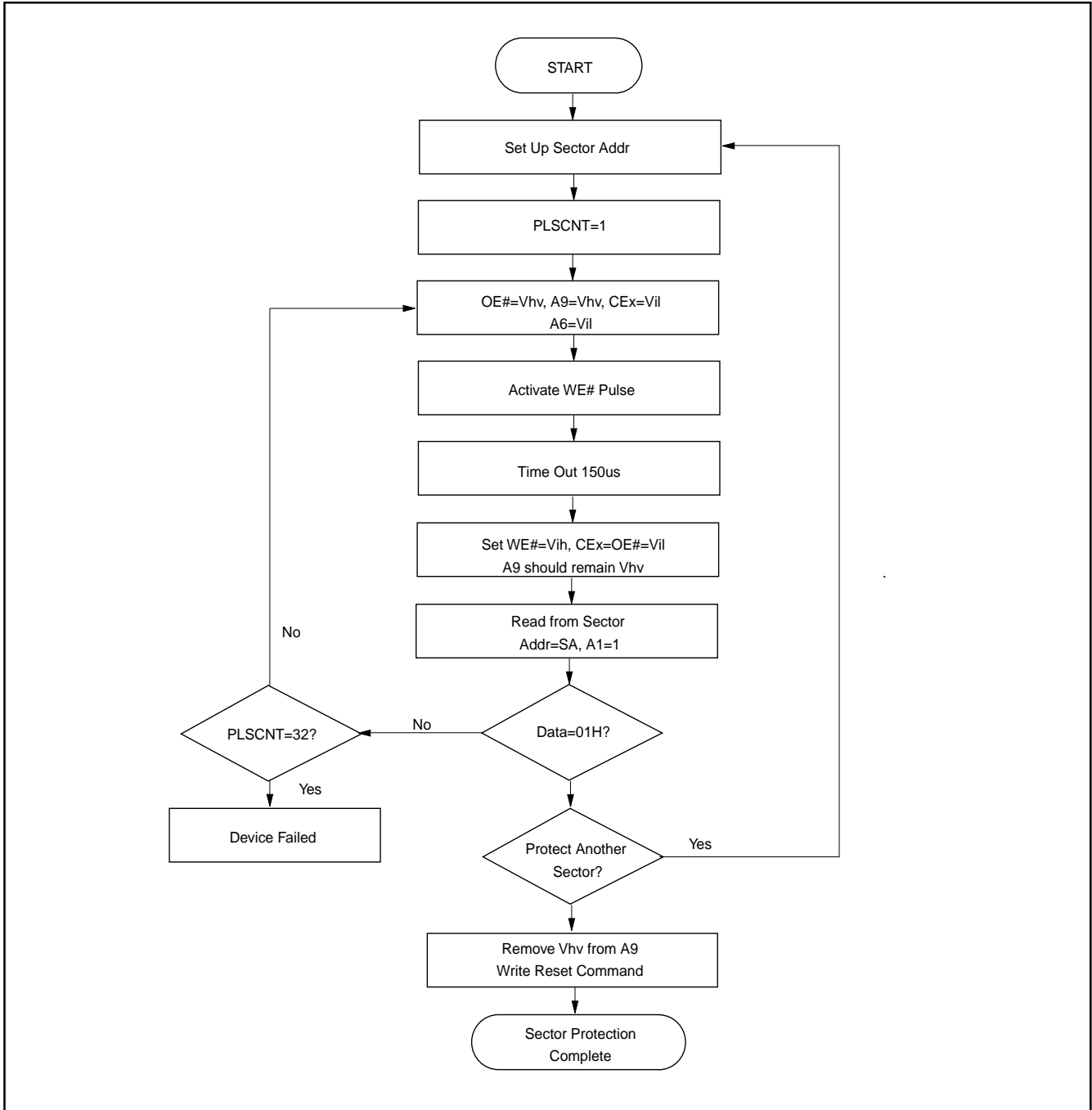

Figure 18. CHIP UNPROTECT TIMING WAVEFORM (A9, OE# Control)

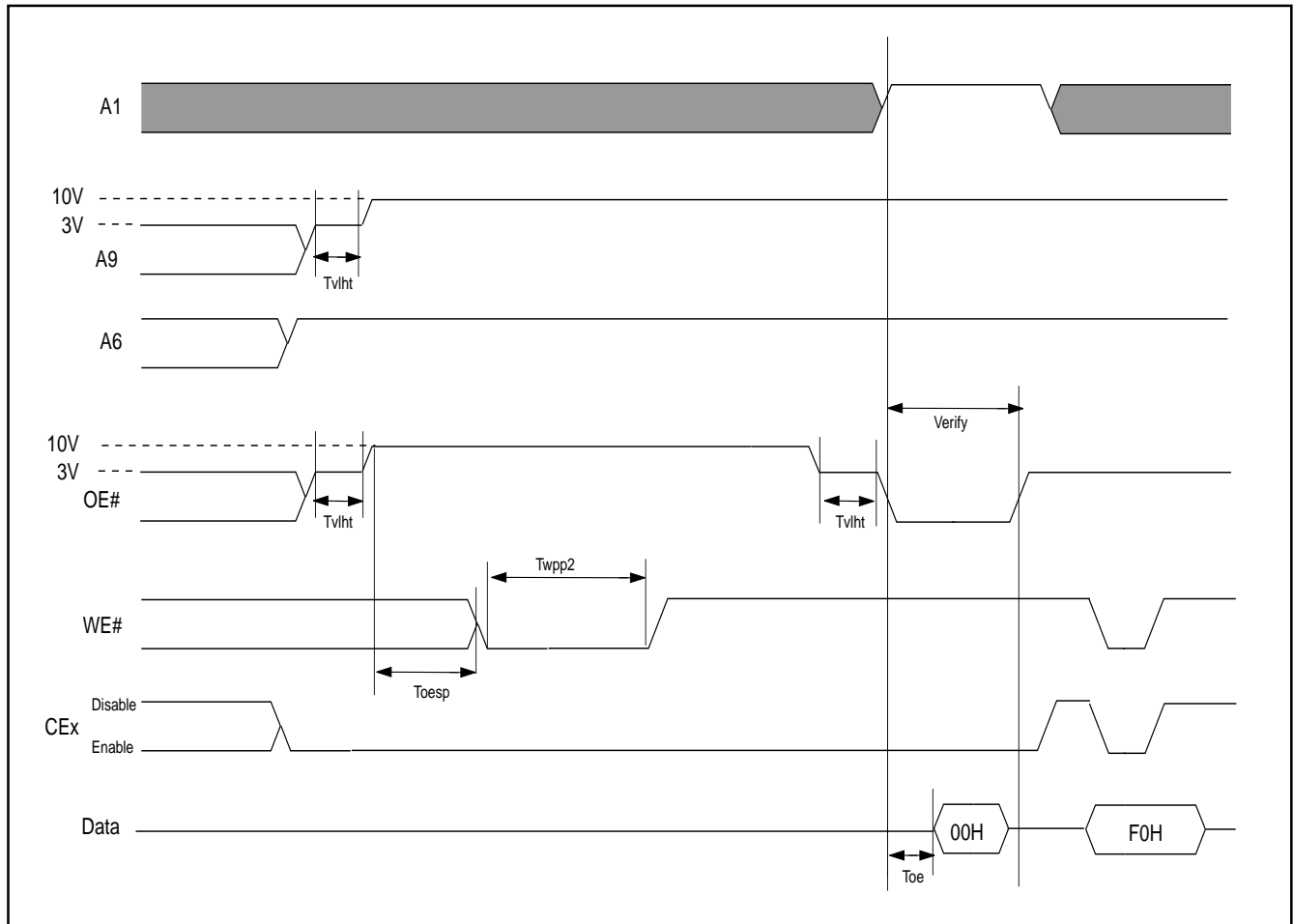
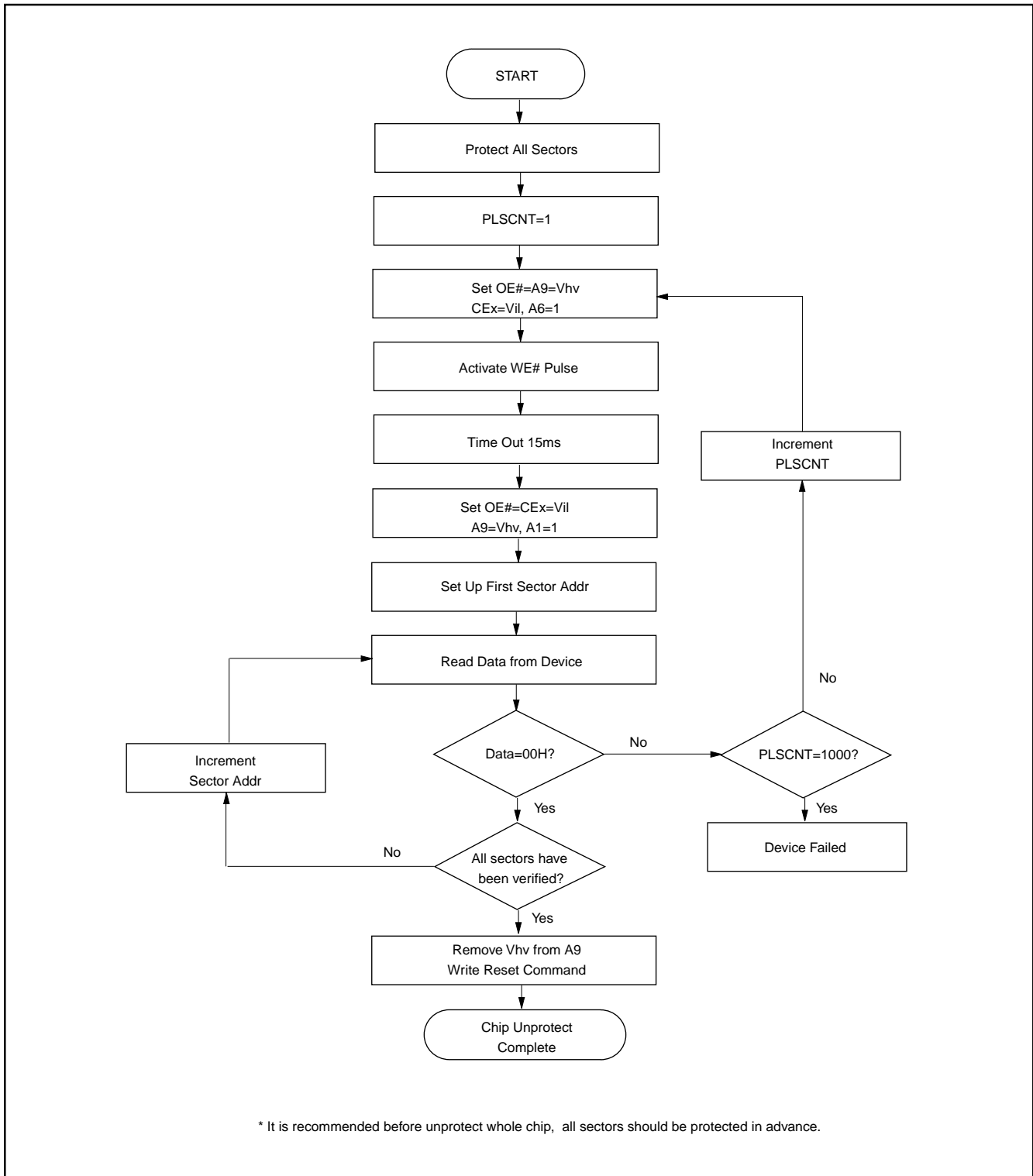

Figure 19. CHIP UNPROTECT FLOWCHART (A9, OE# Control)



AC CHARACTERISTICS

Parameter	Alt	Description	Condition	Speed	Unit
Trpvhh	Tvidr	RESET# Rise Time to Vhv and Vhv Fall Time to RESET#	MIN	500	ns
Tvhhwl	Trsp	RESET# Vhv to WE# Low	MIN	4	us

Figure 20. TEMPORARY SECTOR UNPROTECT WAVEFORMS

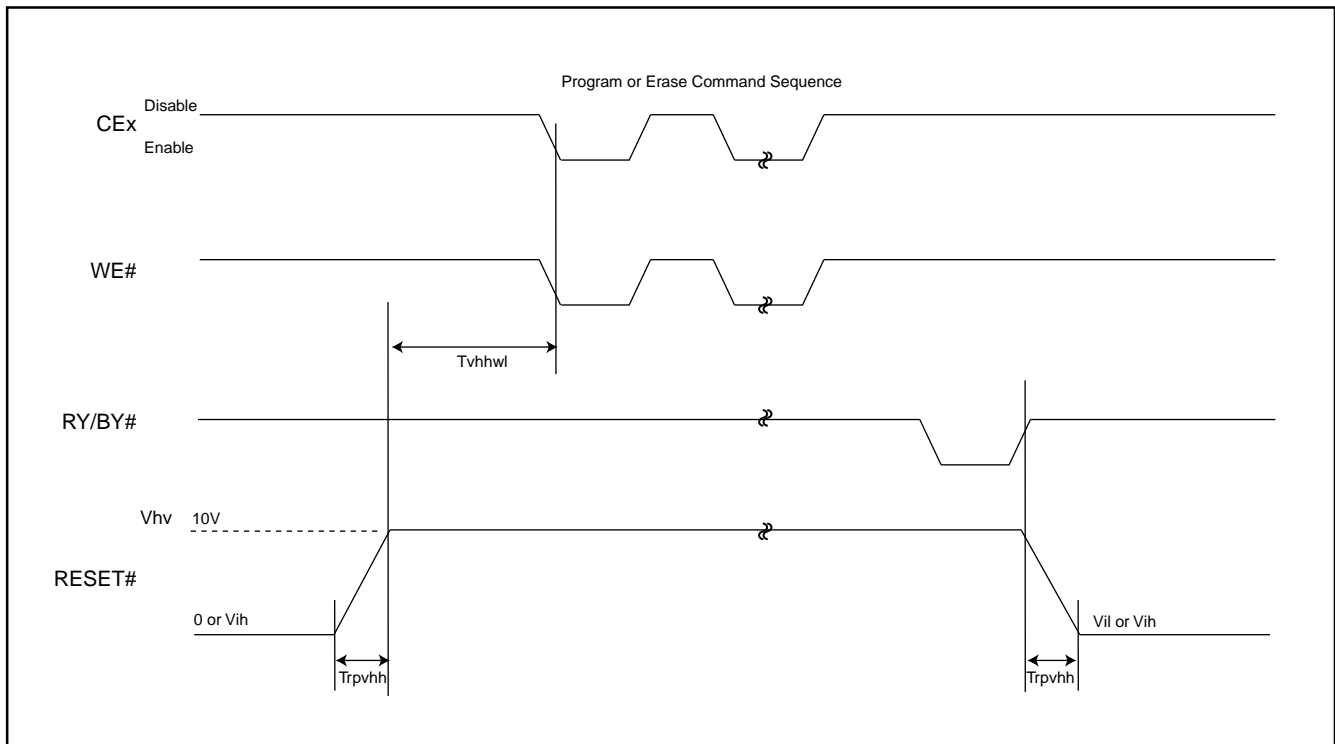
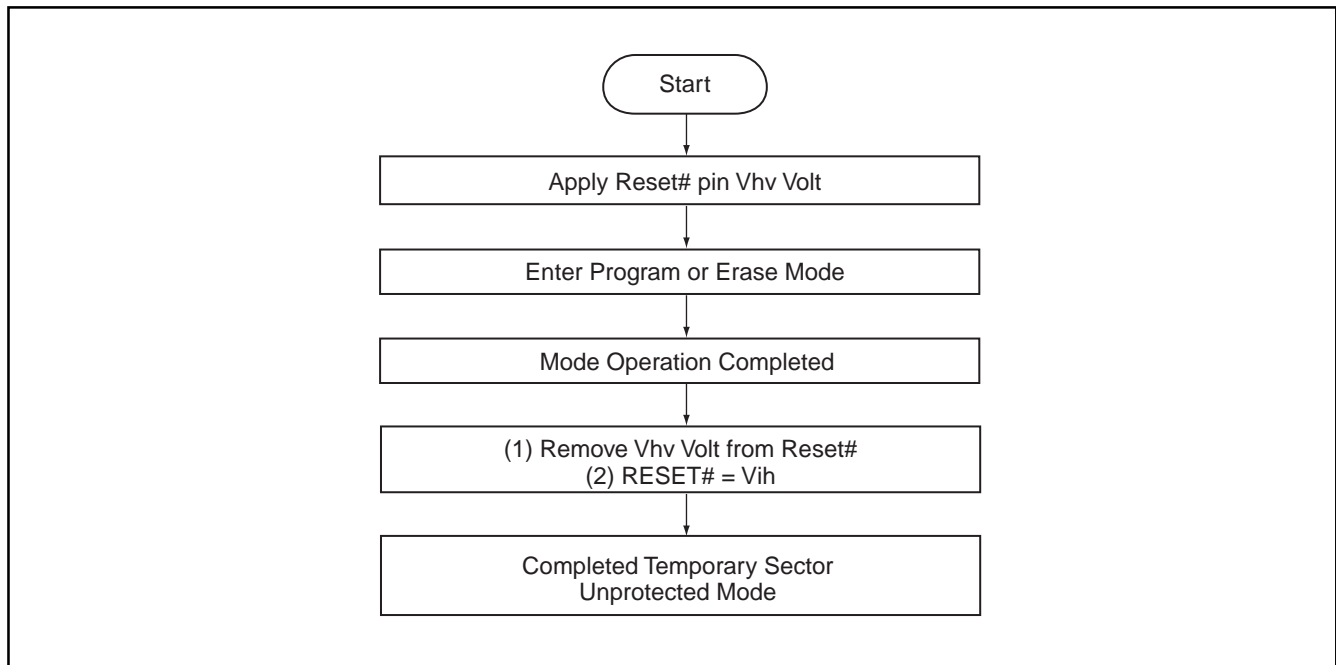
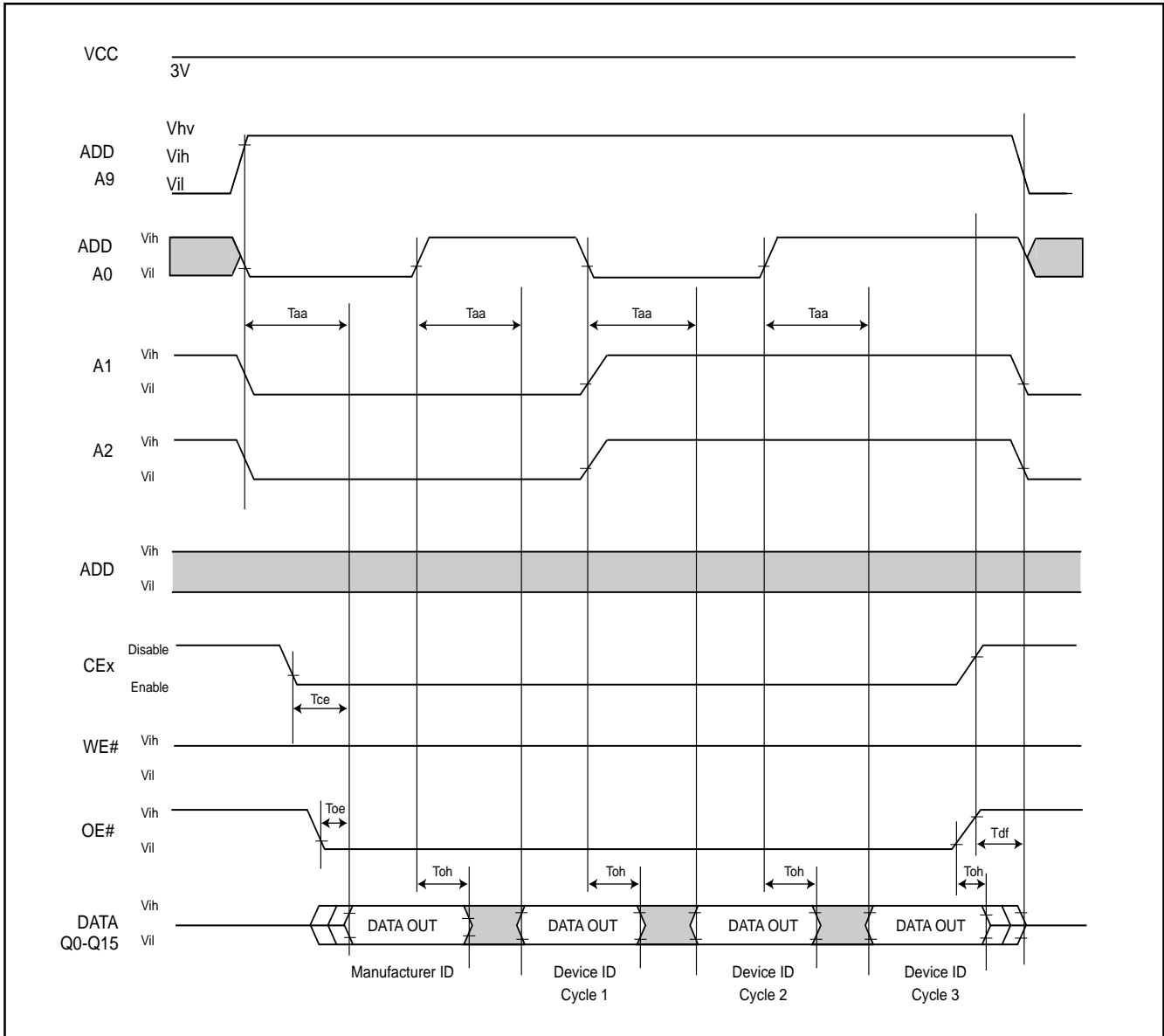

Figure 21. TEMPORARY SECTOR UNPROTECT FLOWCHART**Notes:**

1. Temporary unprotect all protected sectors Vhv=9.5~10.5V.
2. After leaving temporary unprotect mode, the previously protected sectors are again protected.

Figure 22. SILICON ID READTIMING WAVEFORM



WRITE OPERATION STATUS

Figure 23. DATA# POLLING TIMING WAVEFORMS (DURING AUTOMATIC ALGORITHMS)

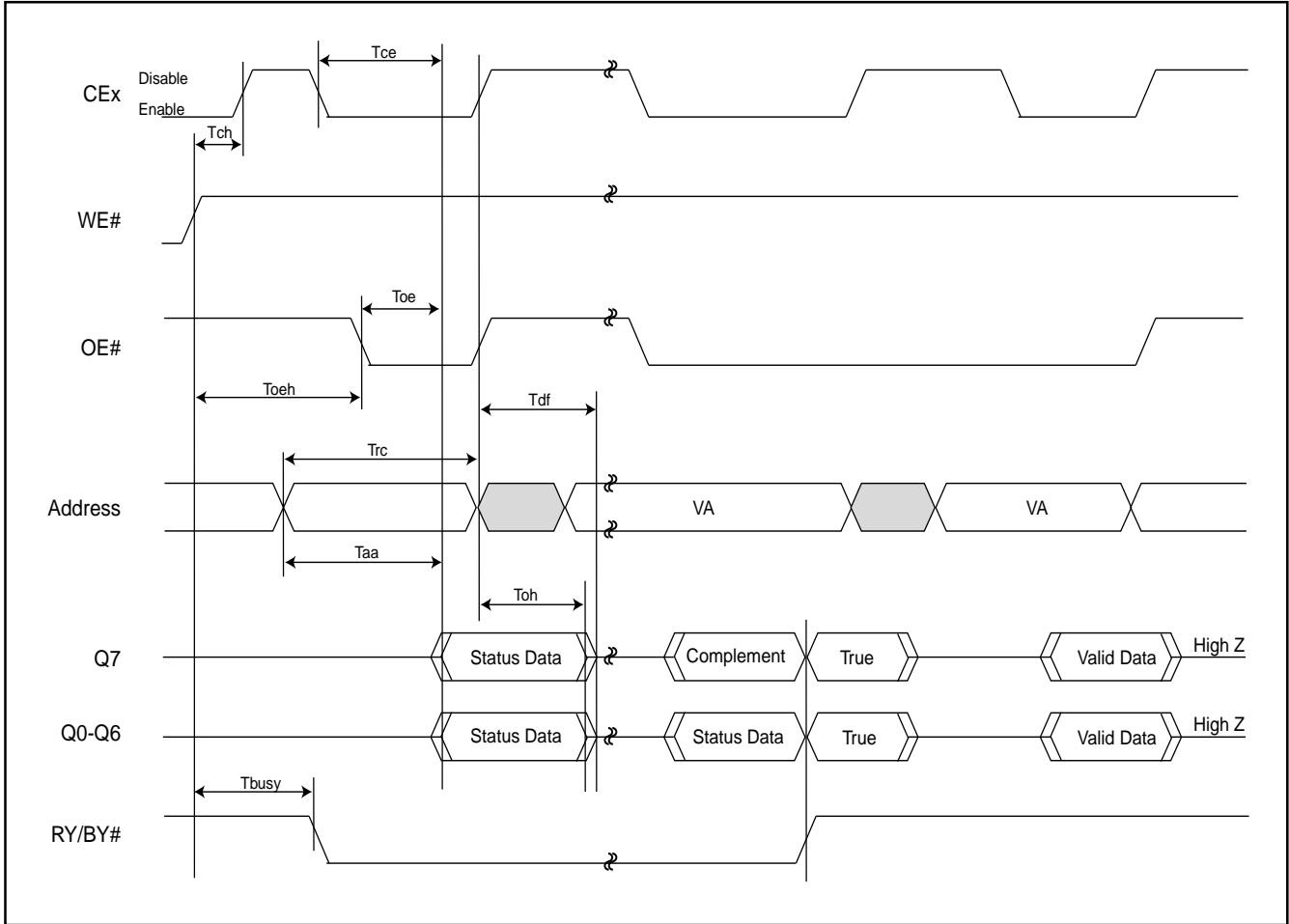
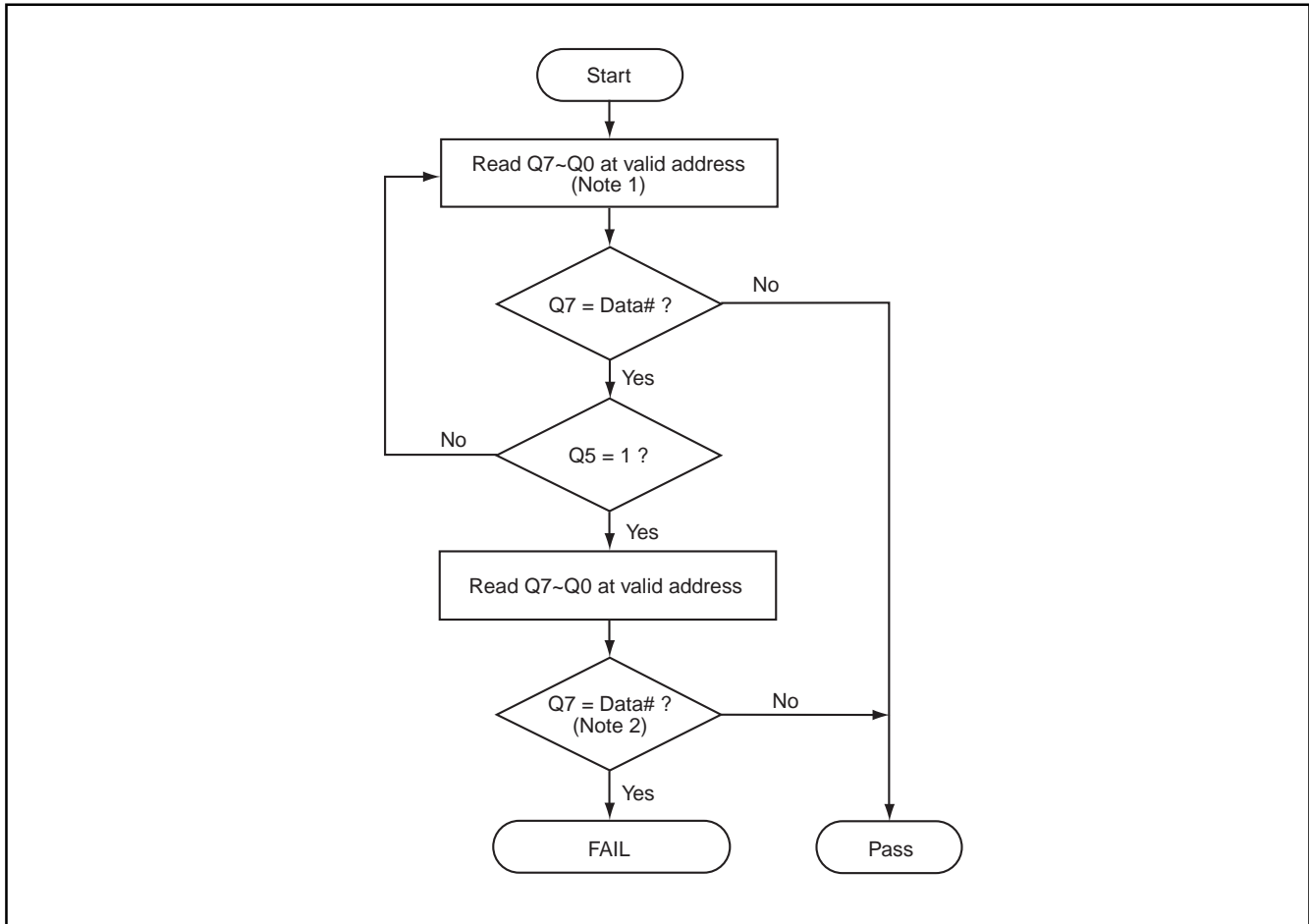

Figure 24. DATA# POLLING ALGORITHM



Notes:

1. For programming, valid address means program address.
For erasing, valid address means erase sectors address.
2. Q7 should be rechecked even Q5="1" because Q7 may change simultaneously with Q5.

Figure 25. TOGGLE BIT TIMING WAVEFORMS (DURING AUTOMATIC ALGORITHMS)

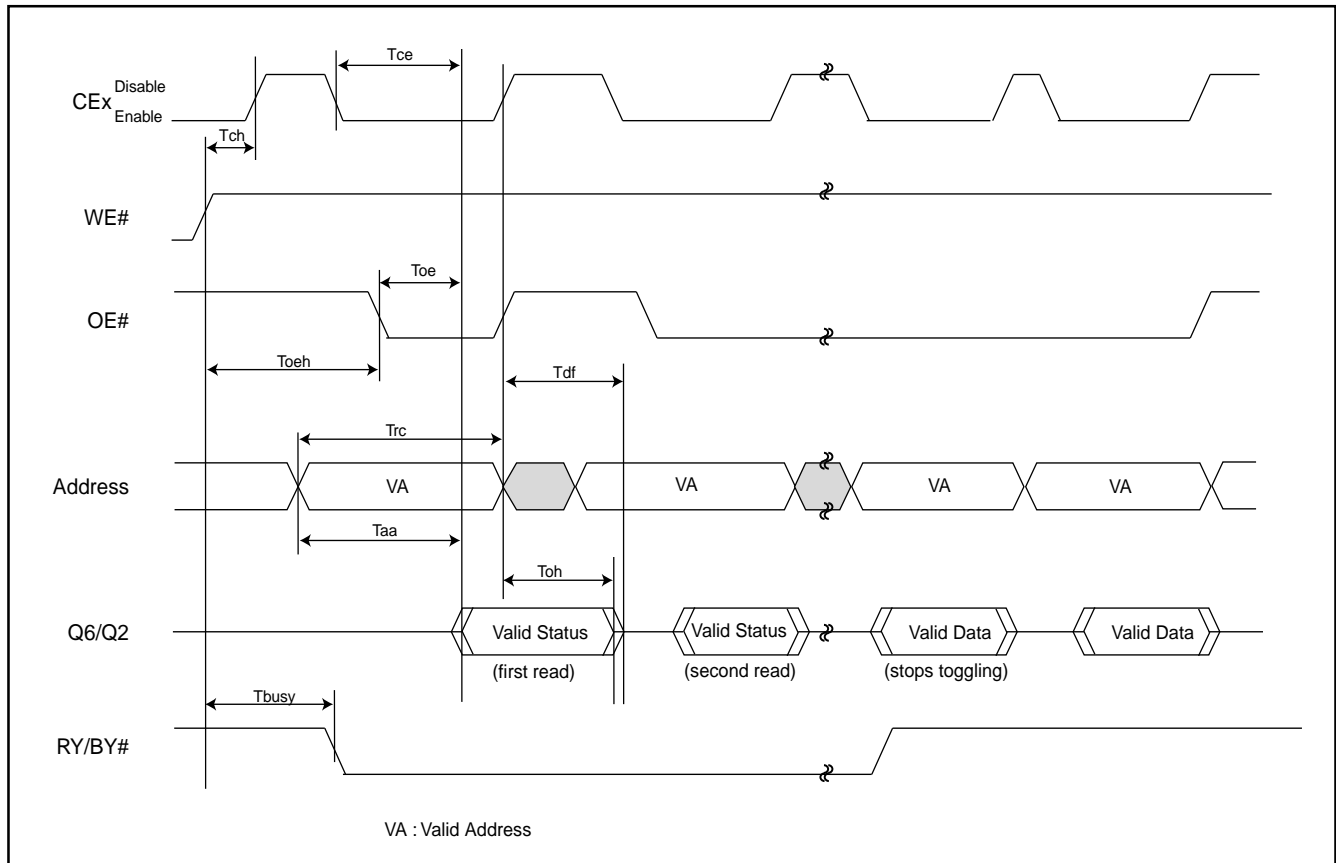
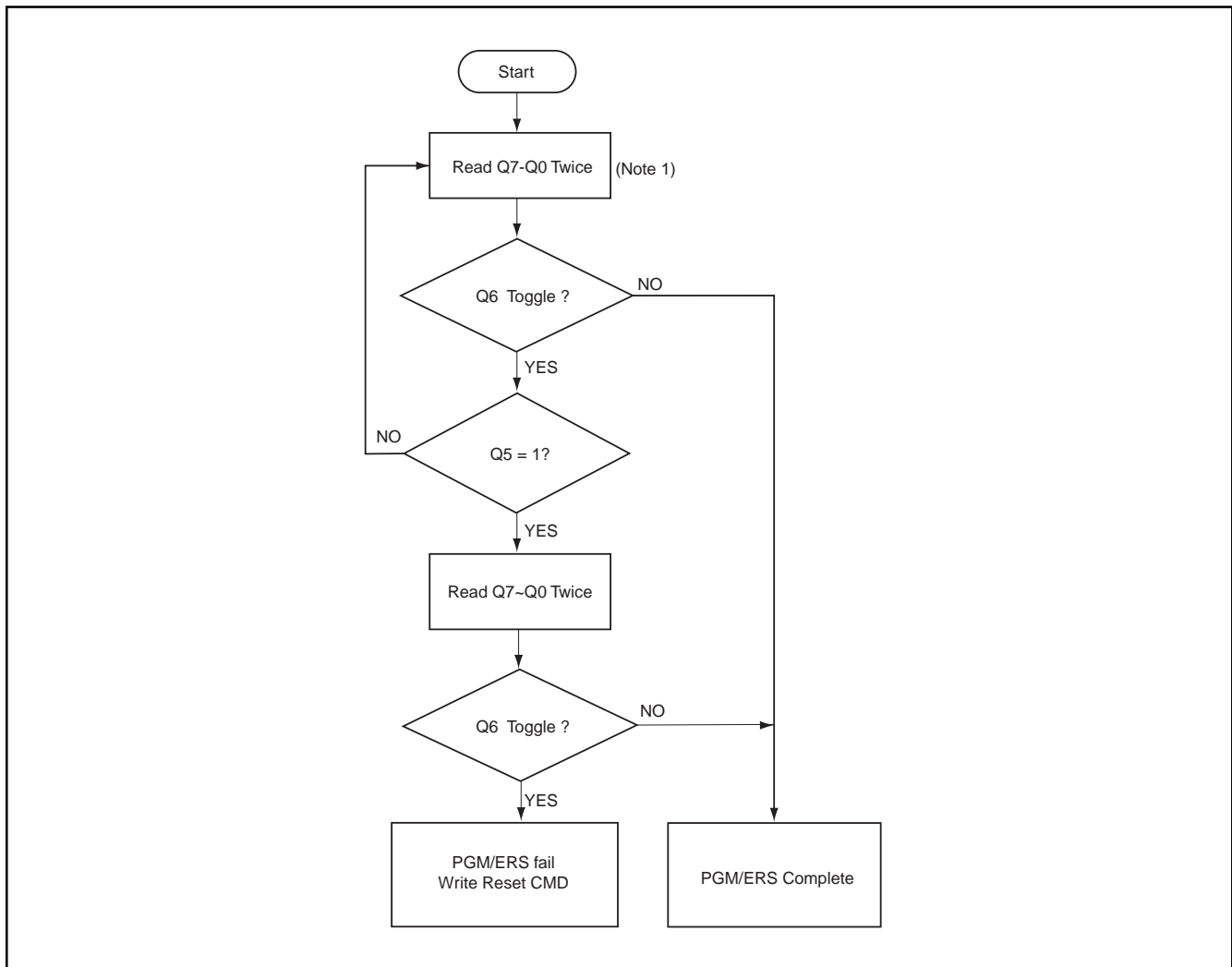
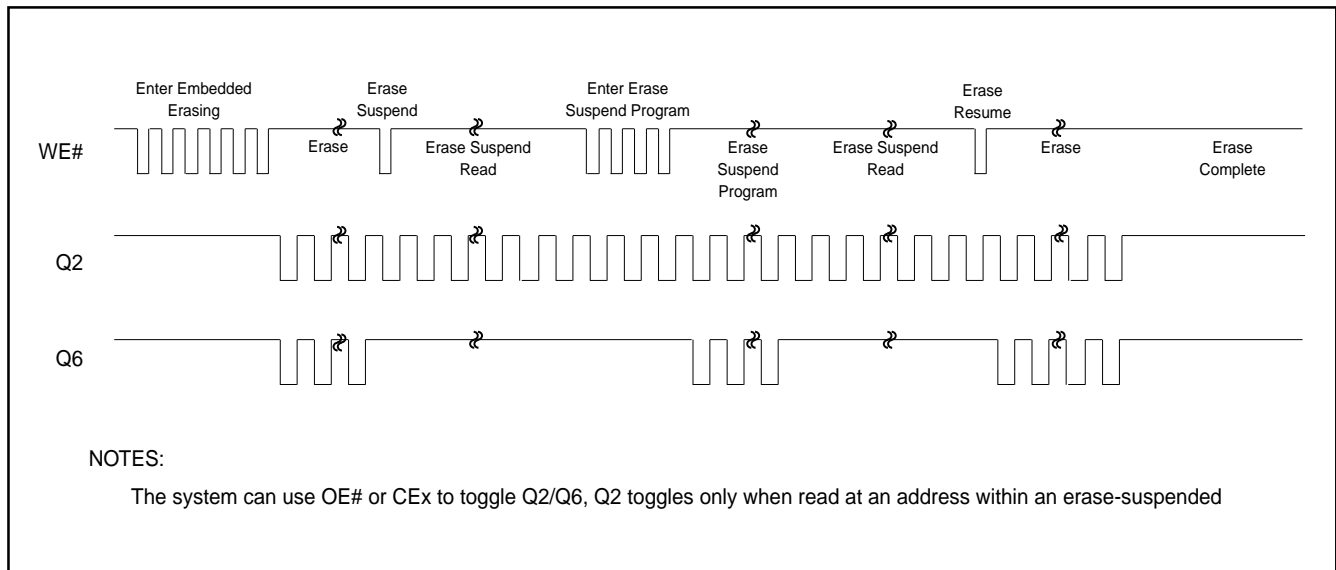

Figure 26. TOGGLE BIT ALGORITHM**Note:**

1. Read toggle bit twice to determine whether or not it is toggling.
2. Recheck toggle bit because it may stop toggling as Q5 changes to "1".

Figure 27. Q6 versus Q2



RECOMMENDED OPERATING CONDITIONS

At Device Power-Up

AC timing illustrated in Figure A is recommended for the supply voltages and the control signals at device power-up. If the timing in the figure is ignored, the device may not operate correctly.

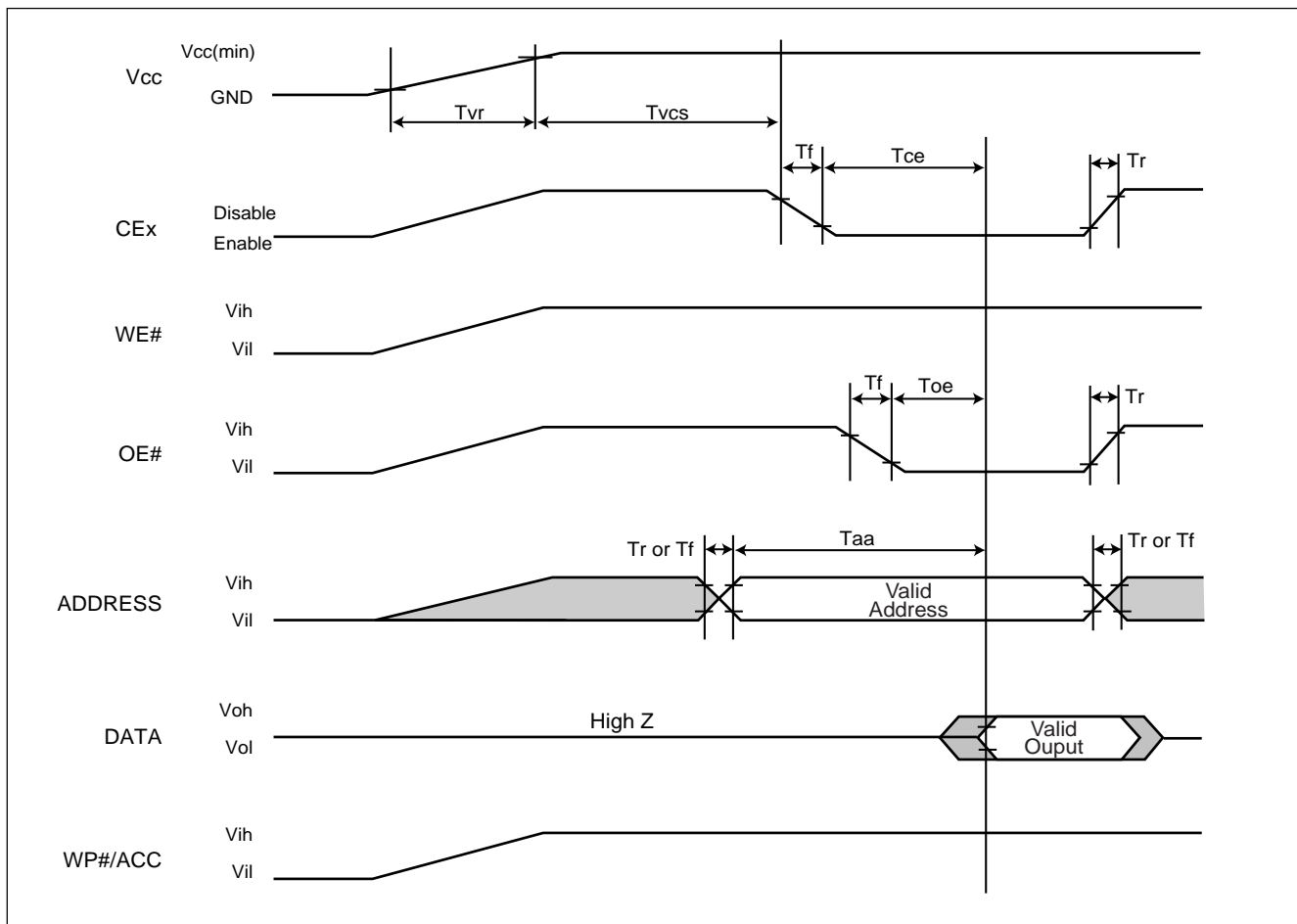

Figure A. AC Timing at Device Power-Up

Symbol	Parameter	Min.	Max.	Unit
T_{vr}	Vcc Rise Time	80	500000	us/V
T_r	Input Signal Rise Time		20	us/V
T_f	Input Signal Fall Time		20	us/V
T_{vcs}	Vcc Setup Time	200		us

ERASE AND PROGRAMMING PERFORMANCE

PARAMETER	LIMITS			UNITS
	MIN.	TYP.(2)	MAX.	
Sector Erase Time		0.7	2	sec
Chip Erase Time		45	65	sec
Word Programming Time		11	360	us
Byte Programming Time		9	300	us
Accelerated Byte/Word Program Time		7	210	us
Chip Programming Time	Byte mode	50	160	sec
	Word mode	45	140	sec
Erase/Program Cycles		100,000		Cycles

Notes:

1. Typical program and erase times assume the following conditions: 25° C, 3.0V VCC. Programming specifications assume checkboard data pattern.
2. Maximum values are measured at VCC = 3.0 V, worst case temperature. Maximum values are valid up to and including 100,000 program/erase cycles.
3. Word/Byte programming specification is based upon a single word/byte programming operation not utilizing the write buffer.
4. Erase/Program cycles comply with JEDEC JESD-47E & A117A standard.

LATCH-UP CHARACTERISTICS

	MIN.	MAX.
Input Voltage voltage difference with GND on WP#/ACC, A9, OE#, RESET# pins	-1.0V	10.5V
Input Voltage voltage difference with GND on all I/O pins	-1.0V	1.5 x Vcc
Vcc current pulse	-100mA	+100mA
Includes all pins except Vcc. Test conditions: Vcc = 3.0V, one pin at a time.		

PIN CAPACITANCE

Parameter Symbol	Parameter Description	Test Set	TYP	MAX	UNIT
CIN	Input Capacitance	VIN=0	6	7.5	pF
COUT	Output Capacitance	VOUT=0	8.5	12	pF
CIN2	Control Pin Capacitance	VIN=0	7.5	9	pF

Notes:

1. Test conditions TA=25° C, f=1.0MHz.



MACRONIX
INTERNATIONAL Co., LTD.

MX29LA641D H/L

ORDERING INFORMATION

Please contact Macronix sales for specific information regarding 64-ball BGA (10x13mm) ordering information.



MACRONIX
INTERNATIONAL Co., LTD.

MX29LA641D H/L

PART NAME DESCRIPTION

Please contact Macronix sales for specific information regarding 64-ball BGA (10x13mm) part name description.

PACKAGE INFORMATION

Title: Package Outline for CSP 64BALL(10X13X1.2MM,BALL PITCH 1.00MM,BALL DIAMETER 0.4MM)

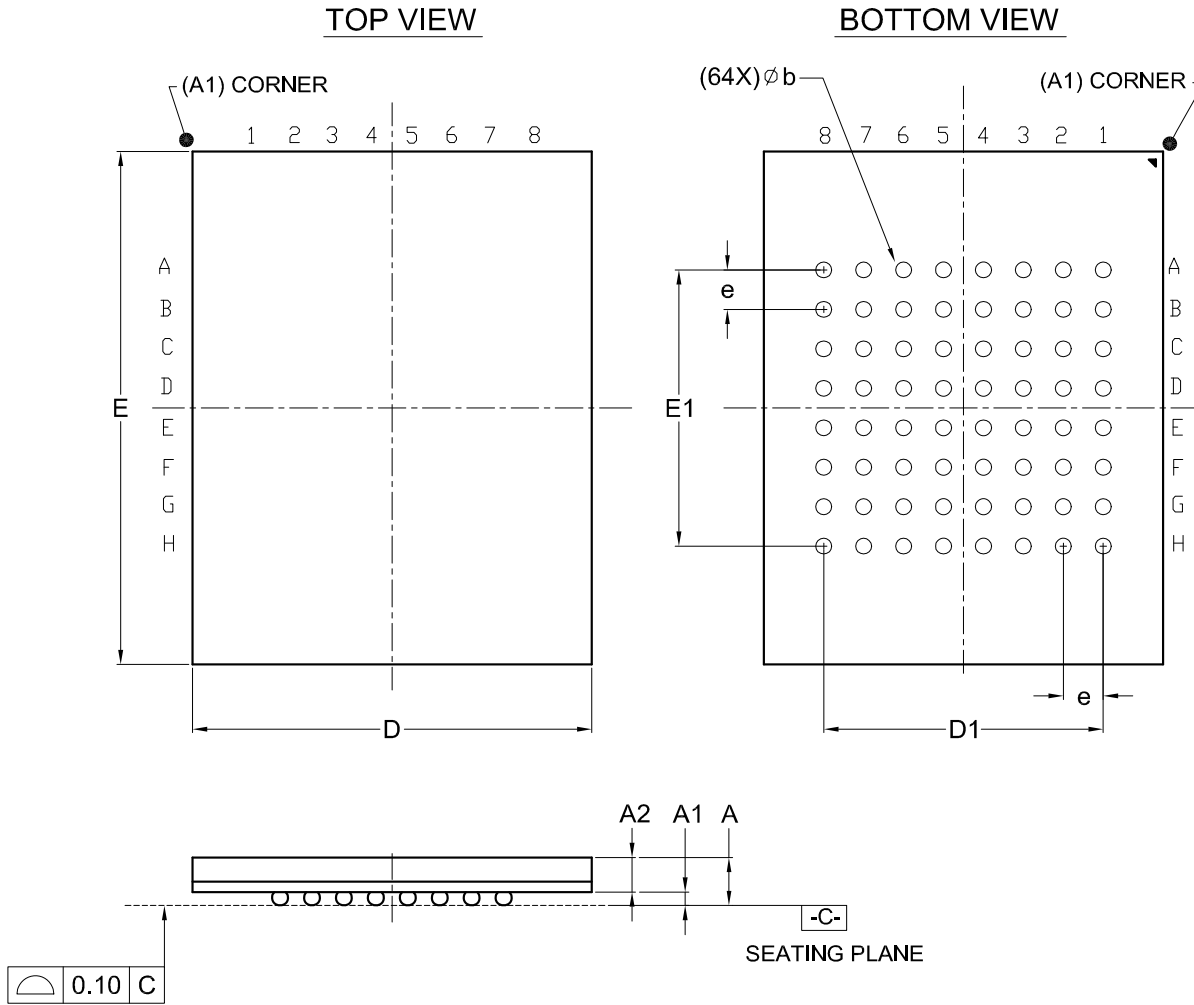

Dimensions (inch dimensions are derived from the original mm dimensions)

SYMBOL		A	A1	A2	b	D	D1	E	E1	e
mm	Min.	---	0.25	0.65	0.35	9.90		12.90		
	Nom.	---	0.30	---	0.40	10.00	7.00	13.00	7.00	1.00
	Max.	1.20	0.35	---	0.45	10.10		13.10		
Inch	Min.	---	0.010	0.026	0.014	0.390		0.508		
	Nom.	---	0.012	---	0.016	0.394	0.276	0.512	0.276	0.039
	Max.	0.047	0.014	---	0.018	0.398		0.516		

DWG.NO.	REVISION	REFERENCE			ISSUE DATE
		JEDEC	EIAJ		
6110-4220	3	MO-216			12-15-03

REVISION HISTORY

Revision No.	Description	Page	Date
1.0	1. Format changed	All	AUG/29/2008
	2. Corrected WP# function description	P10,11,14	
	3. Revised Sector Erase Time	P29,58	
	4. Changed Vhv spec as 9.5V~10.5V	P39	
	5. Removed "Advanced Information"	P1	
	6. Revised GENERAL DESCRIPTION	P2	
	7. Revised AUTOMATIC SELECT OPERATION	P16	
	8. Revised SOFTWARE COMMAND DEFINITIONS	P17	
1.1	1. Modified table 2-2. 2nd cycle from 1Dh to 13h	P11	JAN/06/2008

Macronix's products are not designed, manufactured, or intended for use for any high risk applications in which the failure of a single component could cause death, personal injury, severe physical damage, or other substantial harm to persons or property, such as life-support systems, high temperature automotive, medical, aircraft and military application. Macronix and its suppliers will not be liable to you and/or any third party for any claims, injuries or damages that may be incurred due to use of Macronix's products in the prohibited applications.

MACRONIX INTERNATIONAL Co., LTD.

Macronix Offices : Taiwan

Headquarters, FAB2

Macronix, International Co., Ltd.

16, Li-Hsin Road, Science Park, Hsinchu,
Taiwan, R.O.C.

Tel: +886-3-5786688

Fax: +886-3-5632888

Taipei Office

Macronix, International Co., Ltd.

19F, 4, Min-Chuan E. Road, Sec. 3, Taipei,
Taiwan, R.O.C.

Tel: +886-2-2509-3300

Fax: +886-2-2509-2200

Macronix Offices : China

Macronix (Hong Kong) Co., Limited.

702-703, 7/F, Building 9, Hong Kong Science Park,
5 Science Park West Avenue, Sha Tin,
N.T.

Tel: +86-852-2607-4289

Fax: +86-852-2607-4229

Macronix (Hong Kong) Co., Limited, SuZhou Office

No.5, XingHai Rd, SuZhou Industrial Park,
SuZhou China 215021

Tel: +86-512-62580888 Ext: 3300

Fax: +86-512-62586799

Macronix (Hong Kong) Co., Limited, Shenzhen Office

Room 1401 & 1404, Bldcok A, TianAN Hi-Tech PLAZA Tower,
Che Gong Miao, FutianDistrict, Shenzhen PRC 518040

Tel: +86-755-83433579

Fax: +86-755-83438078

Macronix Offices : Japan

Macronix Asia Limited.

NKF Bldg. 5F, 1-2 Higashida-cho,
Kawasaki-ku Kawasaki-shi,
Kanagawa Pref. 210-0005, Japan

Tel: +81-44-246-9100

Fax: +81-44-246-9105

Macronix Offices : Korea

Macronix Asia Limited.

#906, 9F, Kangnam Bldg., 1321-4, Seocho-Dong, Seocho-Ku,
135-070, Seoul, Korea

Tel: +82-02-588-6887

Fax: +82-02-588-6828

Macronix Offices : Singapore

Macronix Pte. Ltd.

1 Marine Parade Central, #11-03 Parkway Centre,
Singapore 449408

Tel: +65-6346-5505

Fax: +65-6348-8096

Macronix Offices : Europe

Macronix Europe N.V.

Koningin Astridlaan 59, Bus 1 1780
Wommel Belgium

Tel: +32-2-456-8020

Fax: +32-2-456-8021

Macronix Offices : USA

Macronix America, Inc.

680 North McCarthy Blvd. Milpitas, CA 95035,
U.S.A.

Tel: +1-408-262-8887

Fax: +1-408-262-8810

<http://www.macronix.com>