

DEDICATED POWER CONVERTER FOR POWER SYSTEM LH(ER2) SERIES

10-25W, AC-DC CONVERTER

LH(ER2) series ----- is the improved version of Mornsun's dedicated power converter for power systems. It accepts universal voltage range for both DC and AC input. LH(ER2) feature high efficiency, high reliability with 3KV isolation. It offers good EMC performance, meets IEC61000 standards, surge meets level 4 standards, and widely used in power systems applications.



RoHS

PRODUCT FEATURES

1. Universal Input :85 ~ 264VAC,50/60Hz
2. Regulated output with high efficiency
3. Short circuit, over-current and thermal protection
4. UL94V-0 plastic case material
5. Meet CLASS I,safety
6. EMC meets IEC/EN61000-4,CISPR22/EN55022 standard
7. Three years product warranty
8. Special designed for power systems
9. Mounting: PCB, Chassis with Screw Terminals, DIN-Rail.

MODEL SELECTION

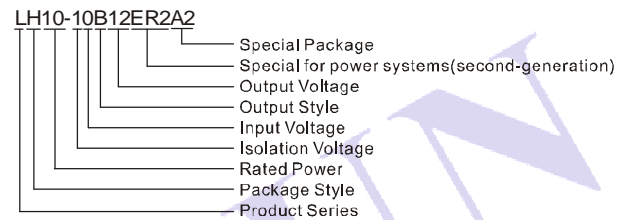

SELECTION GUIDE

Model	Dimension	Power	Output (Vo1/Io1)	Output (Vo2/Io2)	Ripple and Noise	Efficiency (%) (Typ.)
LH10-10B12ER2	62X45X30mm	10W	12V/900mA		100mV	79
LH10-10B24ER2*			24V/450mA			81
LH10-10D0505-02ER2*			5V/1800mA	5V/200mA		75
LH10-10D0512-02ER2*			5V/1500mA	12V/200mA		77
LH10-10D0524-02ER2			5V/1000mA	24V/200mA		77
LH15-10B05ER2*		15W	5V/2800mA			76
LH15-10B12ER2			12V/1250mA			80
LH15-10B24ER2*			24V/650mA			83
LH15-10D0512-04ER2*			5V/2000mA	12V/400mA		80
LH15-10D0524-02ER2			5V/2000mA	24V/200mA		80
LH25-10B05ER2*	25W		5V/4100mA		74	
LH25-10B12ER2			12V/2100mA		81	
LH25-10B24ER2*		24V/1100mA		85		

Note: * Designing.

INPUT SPECIFICATIONS

Input Voltage Range	85~264VAC, 120~370VDC		
Input Frequency	47~63Hz		
Input Current	LH10 models LH15 models LH25 models	110VAC 230mA, typ. 250mA, typ. 420mA, typ.	230VAC 120mA, typ. 140mA, typ. 230mA, typ.
Inrush Current	LH10 models LH15 models LH25 models	110VAC 10A, typ. 10A, typ. 16A, typ.	230VAC 20A, typ. 20A, typ. 30A, typ.
Leakage Current	0.3mA RMS typ./230VAC/50Hz		
Recommended External Input Fuse (Special package series include fuse)	LH10/LH15 models LH25 models	2A/250V 3.15A/250V	slow blow slow blow

OUTPUT SPECIFICATIONS

Output Voltage Accuracy		±2% (main output) ±10% (supplement output)	
Line Regulation		±0.5% (main output) ±1.5% (supplement output)	
Load Variation (10-100%)	Single output models	±1%	
	Isolated and separated dual output (balanced load)	Vo1: ±3% (main output) Vo2: ±5% (supplement output)	
Minimum load	Single output models	0%	
	Isolated and separated dual output (balanced load)	10%	
Ripple & Noise(p-p)	(20MHz Bandwidth)	100mV (Typ.)	200mV (Max.)
Short Circuit Protection		Continuous, auto resume	
Over Current Protection		≥110% Io auto resume	
Over Output Voltage Protection	5VDC models	≤7.5VDC	
	12VDC models	≤20VDC	
	24VDC models	≤30VDC	

GENERAL SPECIFICATIONS

Temperature Ranges	Operating	-40°C ~ +70°C		
	Power derating (55~70°C) (-40~-10°C)	3.75% / °C 2% / °C		
	Storage	-40°C ~ +105°C		
	Case temperature	+90°C Max.		
Hold-up Time	(Vin=230VAC)	80ms(Typ.)		
Humidity(non condensing)		95%(max)		
Temperature Coefficient		0.02%/°C (main output) 0.15%/°C (supplement output)		
Switching Frequency		60KHz (Typ.)		
I/O-isolation Voltage		3000VAC/1Min		
EMC compliance	EMI	RE	CISPR22/EN55022 CLASS A (Without External Circuit) / CLASS B (Typical Application Circuit Refer to Figure 3)	
		CE	CISPR22/EN55022 CLASS A (Without External Circuit) / CLASS B (Typical Application Circuit Refer to Figure 3)	
	EMS	ESD	IEC/EN61000-4-2 Contact ±6KV / Air ±8KV	perf. Criteria B
		RS	IEC/EN61000-4-3 10V/m	perf. Criteria A
		EFT	IEC/EN61000-4-4 ±4KV	perf. Criteria B
		Surge	IEC/EN61000-4-5 ±2KV/±4KV	perf. Criteria B
			(Without External Circuit)	
			IEC/EN61000-4-5 ±4KV/±6KV	perf. Criteria B
			(Typical Application Circuit Refer to Figure 3)	
		CS	IEC/EN61000-4-6 10 Vr.m.s	perf. Criteria A
PFM	IEC/EN61000-4-8 10A/m	perf. Criteria A		
Voltage dips、 Short and Interruptions immunity	IEC/EN61000-4-11 0%-70%	perf. Criteria B		
Safety Standard		CLASS I		
Case Material		UL94V-0		
Mounting		PCB / SCREW TERMINAL / DIN RAIL		
MTBF		>300,000h @25°C		
Package	LH10/15 models	62x45x30mm		
	LH25 models	70x48x30mm		
<p>Note: 1.The indicated EMC compliance are tighter than EN55024 standard. 2.Ripple and Noise measurement based on the parallel lines test; 3.Unless otherwise specified, all specifications above are measured at rated input voltage and rated output load, Ta=25°C, humidity < 75%; 4.All specifications stated in this datasheet are subject to the above listed models only. For specifications of non-standard models, please contact our technical support team.</p>				

PARALLEL LINES MEASURE

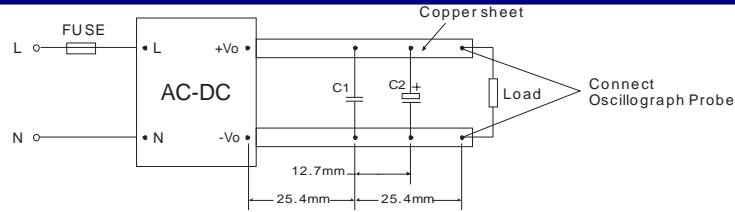

C1: 1 μ F (ceramic capacitor)

C2: 10 μ F (electrolytic capacitor)

TYPICAL EFFICIENCY CURVE

Efficiency VS Output Load curve
($V_{in}=230V_{ac}$)

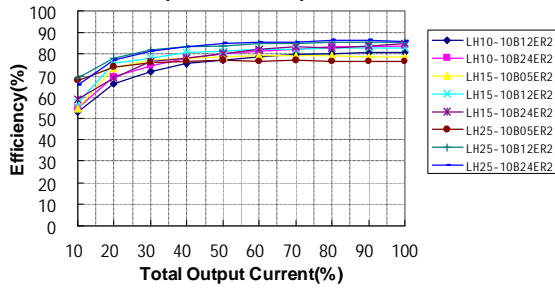

Efficiency VS Input Voltage curve
(Full Load)

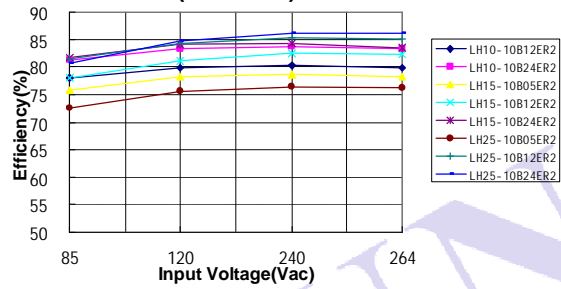

INPUT VOLTAGE VS LOAD

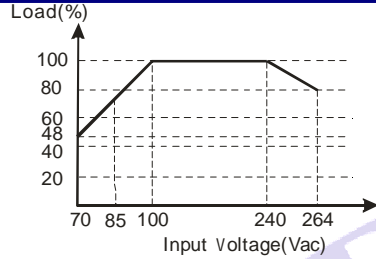

*Note: When input DC, $V_{dc}=1.414V_{ac}-20$.

TEMPERATURE VS LOAD

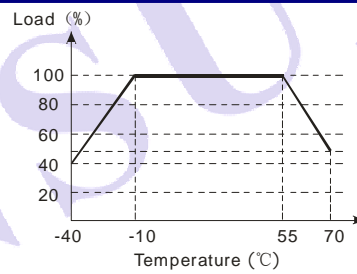

TRIM APPLICATION & TRIM CALCULATION

Application circuit for TRIM
(Part in broken line is the interior of models)

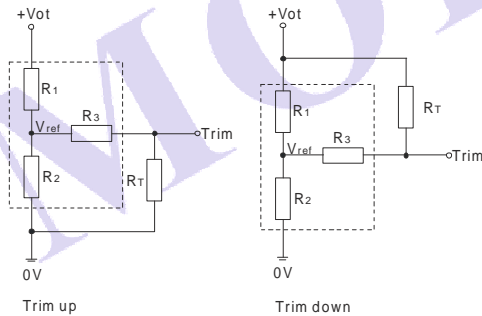

Formula for Trim resistor

$$\text{up: } R_T = \frac{aR_2}{R_2 - a} - R_3 \quad a = \frac{V_{ref}}{V_{ot} - V_{ref}} \cdot R_1$$

$$\text{down: } R_T = \frac{aR_1}{R_1 - a} - R_3 \quad a = \frac{V_{ot} - V_{ref}}{V_{ref}} \cdot R_2$$

Note: Value for R1, R2, R3, and Vref refer to the following table.

R_T : Resistance of Trim

a: User-defined parameter, no actual meanings

V_o (V)	5	12	24
Resistance			
R1(K Ω)	3.3	3.83	8.66
R2(K Ω)	3.3	1	1
R3(K Ω)	1	1	1
Vref(V)	2.5	2.5	2.5
Vot(V)	Output voltage of Trim, variation $\leq \pm 10\%$		

TYPICAL APPLICATIONS

LH**-10B**ER2(Single output)

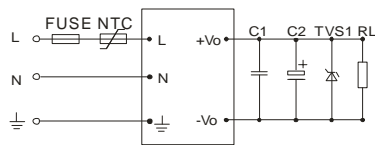

(figure 1)

LH**-10D**ER2(Isolate Twin Output)

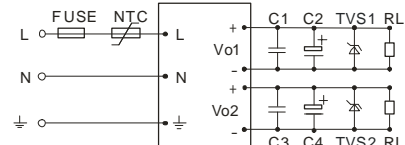

(figure 2)

LH**-10***ER2 series Recommended circuit for application require higher EMC standard (external circuit output same as above):

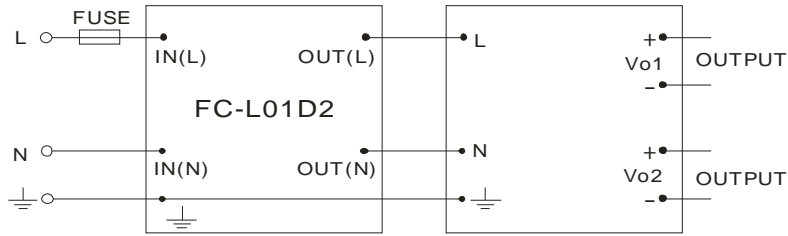

(figure 3)

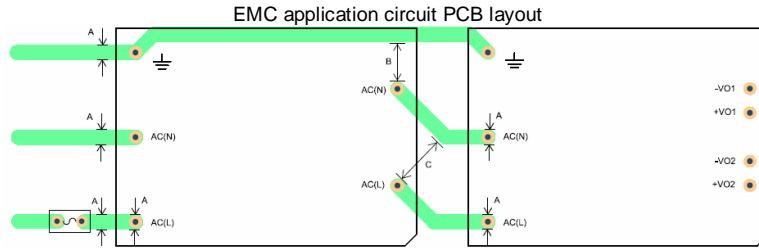

Safety and recommend wiring: linewidth $A \geq 3\text{mm}$, $B \geq 6\text{mm}$, $C \geq 9\text{mm}$

TYPICAL APPLICATION CIRCUIT RECOMMENDED VALUE

MODEL	C2(μF)	TVS1	MODEL	C2(μF)	C4(μF)	TVS1	TVS2
LH10-10B12ER2	120	SMBJ20A	LH10-10D0505-02ER2	220	68	SMBJ7.0A	SMBJ7.0A
LH10-10B24ER2	68	SMBJ30A	LH10-10D0512-02ER2	220	68	SMBJ7.0A	SMBJ20A
LH15-10B05ER2	680	SMBJ7.0A	LH10-10D0524-02ER2	220	47	SMBJ7.0A	SMBJ30A
LH15-10B12ER2	220	SMBJ20A	LH15-10D0524-02ER2	470	47	SMBJ7.0A	SMBJ30A
LH15-10B24ER2	68	SMBJ30A	LH15-10D0512-04ER2	470	220	SMBJ7.0A	SMBJ20A
LH25-10B05ER2	330	SMBJ7.0A					
LH25-10B12ER2	330	SMBJ20A					
LH25-10B24ER2	120	SMBJ30A					

Note:

- Output filter capacitors C2, C4 are electrolytic capacitors, It is recommended to use high frequency and low impedance electrolytic capacitors. For capacitance and current of capacitor please refer to manufacture's datasheet. Voltage derating of capacitor should be 80% or above. C1, C3 are ceramic capacitors, used to filter high frequency noise, suggest choose 1 μF . TVS is recommended component to protect post-circuits (if converter fails)
- External input NTC is recommended to use 5D-9
- For standard EMC requirement, please refer to figure 1 or figure 2, if higher EMC requirement ,please refer to figure 3
 FUSE: LH10/15 recommended to use 2A/250V, LH25 recommended to use 3.15A/250V
 FC-L01D2: Mornsun's 4KV/6KV Surge protector

PCB MOUNTING WITH SOLDER PINS

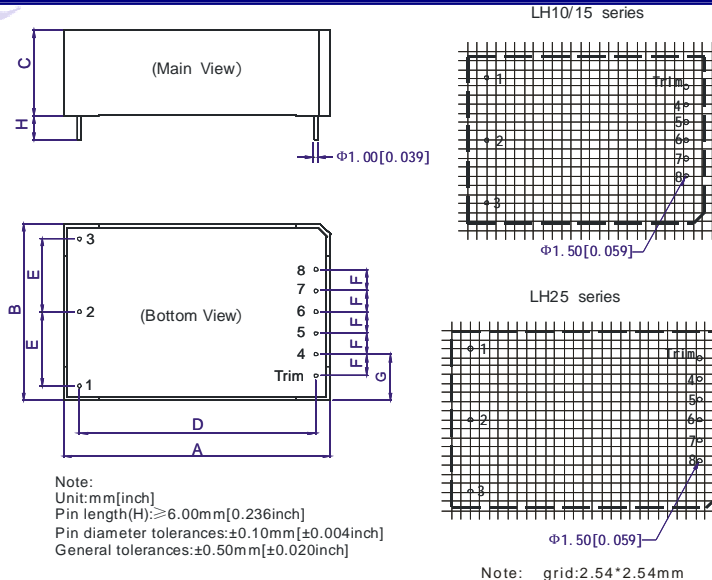

OUTLINE AND DIMENSIONS (Unit: mm)			
NO.	LH10	LH15	LH25
A	62.00	62.00	70.00
B	45.00	45.00	48.00
C	30.00	30.00	30.00
D	54.00	54.00	62.00
E	17.50	17.50	20.00
F	5.00	5.00	5.75
G	12.50	12.50	12.50

FOOTPRINT DETAILS		
Pin	LHXX-10B	LHXX-10D
1		
2	AC(N)	AC(N)
3	AC(L)	AC(L)
4	-Vo	-Vo1
5	No Pin	+Vo1
6	No Pin	No Pin
7	No Pin	-Vo2
8	+Vo	+Vo2
Trim	Trim**	No Pin

Trim**: only for LH25-10BXXER2 Series.

LHXXER2A2 CHASSIS MOUNTING WITH SCREW TERMINALS

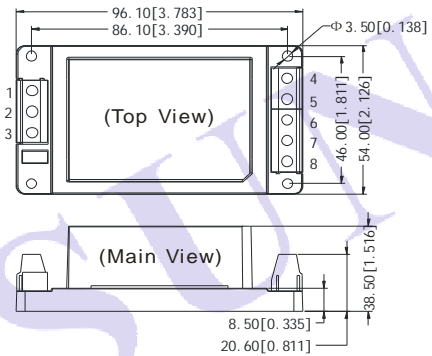

Note:
Unit: mm[inch]
General tolerances: $\pm 0.50\text{mm}[\pm 0.020\text{inch}]$

OUTLINE AND DIMENSIONS (Unit: mm)	
MODEL	DIMENSIONS
LHXXER2A2	96.1x54x38.5mm

MODELS WEIGHT			
WEIGHT	LH10	LH15	LH25
Typ.	150g	150g	180g

FOOTPRINT DETAILS		
Pin	LHXX-10B	LHXX-10D
1		
2	AC(N)	AC(N)
3	AC(L)	AC(L)
4	-Vo	-Vo1
5	NC	+Vo1
6	NC/Trim**	NC
7	NC	-Vo2
8	+Vo	+Vo2

NC/Trim**: The pin is Trim on LH25-10BXXER2A2,
The pin is not connected on other single output products.

LHXXER2A4 DIN-RAIL MOUNTING

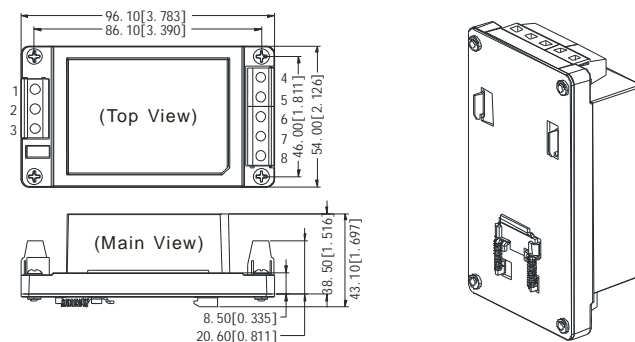

Note:
Unit: mm[inch]
General tolerances: $\pm 0.50\text{mm}[\pm 0.020\text{inch}]$
*Footprint Details are the same as Chassis mounting with Screw Terminals'.

OUTLINE AND DIMENSIONS (Unit: mm)	
MODEL	DIMENSIONS
LHXXER2A4	96.1x54x43.1mm

MODELS WEIGHT			
WEIGHT	LH10	LH15	LH25
Typ.	190g	190g	220g

PACKING INFORMATION

PCB mounting Series

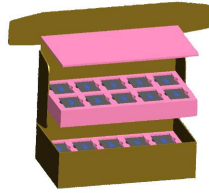

Inner packaging box dimensions: L*W*H=355*192*93mm
 Packaging quantity: 20pcs
 Outer packaging box dimensions:
 L*W*H=405*380*305mm
 Packaging quantity: 120pcs

Special Package Series

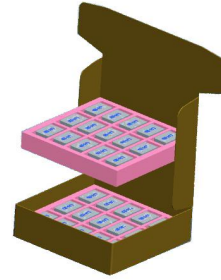

Inner packaging box dimensions: L*W*H=365*350*105mm
 Packaging quantity: 30pcs
 Outer packaging box dimensions:
 L*W*H=390*360*245mm
 Packaging quantity: 60pcs

MORNSUN Science & Technology Co.,Ltd.

Address: No. 5, Kehui St. 1, Kehui development center, Science Ave., Guangzhou Science City, Luogang district, Guangzhou, P.R.China.

Tel: 86-20-28203030

Fax: 86-20-38601272

[Http://www.mornsun-power.com](http://www.mornsun-power.com)