

NEW

Radiometrix

Hartcran House, 231 Kenton Lane, Harrow, HA3 8RP, England

Tel: +44 (0) 20 8909 9595, Fax: +44 (0) 20 8909 2233

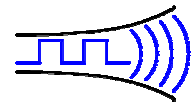

24 August 2007

TX2H-4xx-64

UHF High Power FM Transmitter

The TX2H is a 433/434MHz single-channel FM transmitter module with a power output of 25mW nominal. It is a 100% pin-compatible drop-in replacement for the Radiometrix TX2 and can be used to replace the TX2 in applications where greater radiated power is desired (for example when space limitations dictate the use of small and inefficient antennas, or in countries where the extra power is permitted). The module will handle raw data rates up to 64kb/s. The TX2H transmitter can be used with either RX2 or RX2A receivers.



Figure 1: TX2H-433-64-5V & RX2A-433-64

Features

- Standard frequencies: 433.92MHz and 434.42MHz
- Hi power drop in replacement for TX2
- Data rates up to 64kbps
- Usable range over 500m
- Fully screened
- Low power requirements
- Conforms to European EN 301 489-3 and ETSI EN 300 220-3 (for ERP ≤10mW)
- Conforms to Australian/New Zealand AS/NZS 4268:2003

Instead of the SAW-based technology of the TX2, the TX2H uses a PLL circuit locked to a crystal for better frequency stability over a wider temperature range (-40C to +85C), at the expense of slightly slower power-up.

The TX2H is available as standard on frequencies of 433.92MHz and 434.42MHz at 25mW power output, in either 3V(3.3V) or 5V versions. Custom frequencies may be available to order (consult factory). The module is designed to meet all applicable EMC and type approval requirements.

The module can be made available if required in an extra-high-power version (TX2EH), in the same footprint and pinout but giving 90-100mW nominal output power at 5V supply with a current consumption of less than 45mA (DC to RF conversion efficiency better than 45%).

Applications

- Handheld terminals
- Data loggers
- Industrial telemetry and telecommand
- In-building environmental monitoring and control
- High-end security and fire alarms
- Vehicle data up / download

Technical Summary

- Size: 32 x 12 x 5.5mm
- Operating frequency: 433.92MHz and 434.42MHz
- Supply : 3V or 5V regulated
- Current consumption: 25mA typical
- Data bit rate: 64kbps max.
- Transmit power: +14dBm (25mW) nominal

Functional description

The TX2H transmitter module is a crystal based PLL controlled FM transmitter operating on either 3V or 5V supply and is available in 433.92MHz.

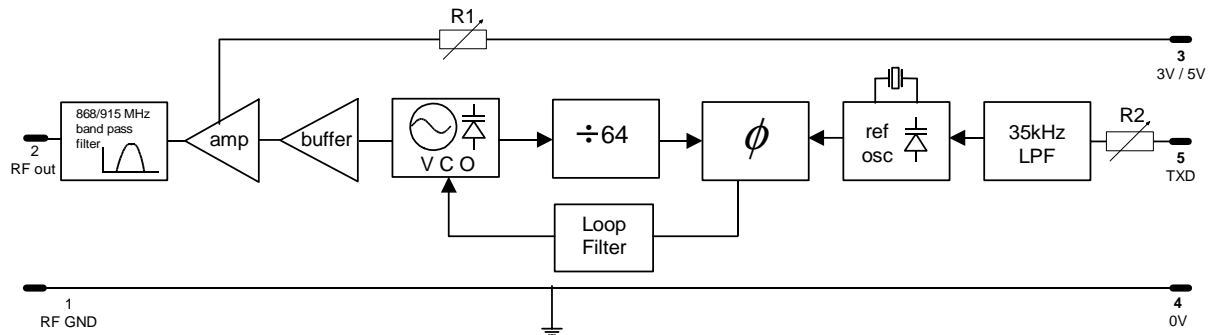

Figure 2: TX2H block diagram

User interface

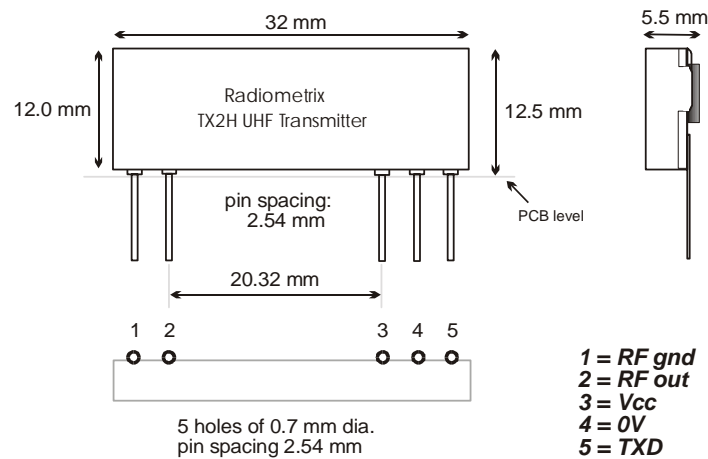

Figure 3: TX2H pin-out and dimension

TX2H pin	Name	Function
1	RFgnd	RF ground, internally connected to the module screen and pin 4 (0V). This pin should be directly connected to the RF return path - e.g. coax braid, main PCB ground plane etc.
2	RF out	50Ω RF output to antenna. Internally DC-isolated.
3	VCC	+ve supply pin. The module will generate RF when the Vcc supply is present. Max ripple content 0.1Vp-p. A 100nF de-coupling ceramic capacitor is suggested.
4	0V	DC supply ground. Internally connected to pin 1 and module screen.
5	TXD	This DC coupled modulation input will accept either serial digital data (0 V to Vcc levels) or high level linear signals. Input impedance is 100 kΩ

Preliminary Specifications (TX2H-433-64-5V):

Figures apply at +25°C, 3.0V or 5.0V supply as applicable, unless otherwise stated.

Operating temperature range	-40°C to +85°C
Supply voltage (3V version)	2.5 - 3.5V (3.0V nominal, 4.0V absolute max.)
Supply voltage (5V version and TX2EH)	4.5 - 5.5V (5.0V nominal, 6.0V absolute max.)
Supply current	25mA typical
Supply current (for TX2EH version)	45mA typical
Output power	+14dBm (25mW), ±1dB
Output power (for TX2EH version)	+20dBm (100mW), ±1dB
DC to RF conversion efficiency (3V version)	33% approx.
DC to RF conversion efficiency (5V version)	20% approx.
DC to RF conversion efficiency (for TX2EH)	45% approx.
Harmonics/spurious emissions	<-36dBm below 1GHz, <-30dBm above 1GHz (<-40dBm typical)
Initial centre frequency accuracy	±15kHz max.
Centre frequency variation over volts/temp	±40kHz max.
FM deviation	±30kHz typical
Power-up time (DC on to full RF output)	1.1ms typical, 1.5ms max.
Baseband bandwidth	DC-35kHz approx.
Maximum raw data rate	64kbps
Required TXD input levels	0V (logic 0), +5V (logic 1). Non-inverting.

Product designations:

TX2H-433-64-3V (433.92MHz, 3V version)
TX2H-433-64-5V (433.92MHz, 5V version)
TX2H-434-64-3V (434.42MHz, 3V version)
TX2H-434-64-5V (434.42MHz, 5V version)
TX2EH-433-64-5V (433.92MHz, 100mW version)
TX2EH-434-64-5V (434.42MHz, 100mW version)

Antenna requirements

Three types of integral antenna are recommended and approved for use with the module:

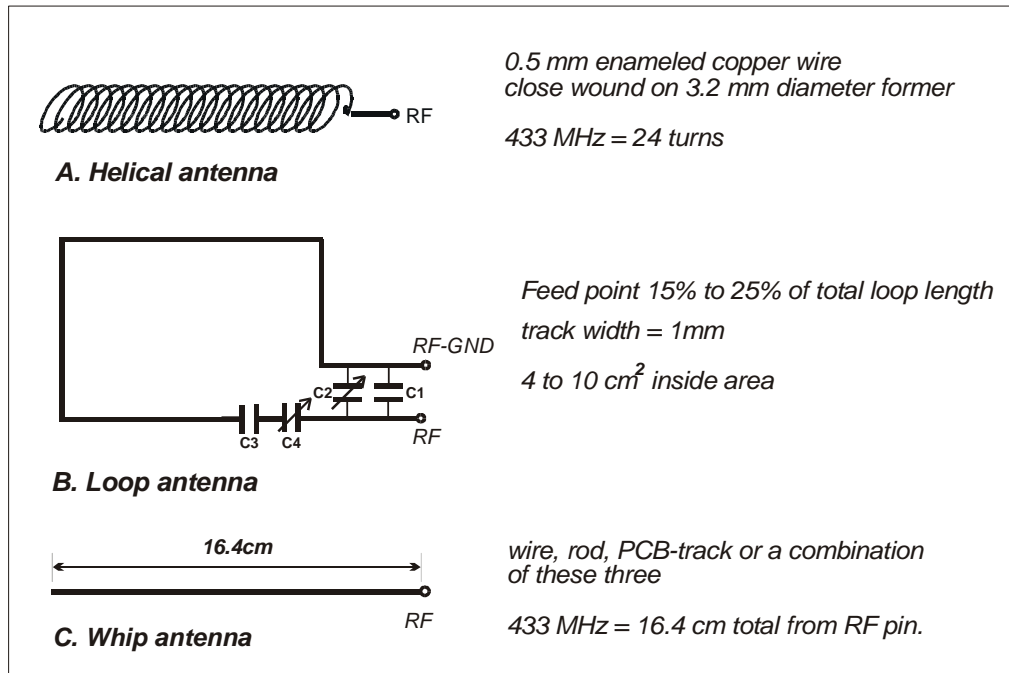

Fig.8: Antenna

	A	B	C
	<i>helical</i>	<i>loop</i>	<i>whip</i>
Ultimate performance	**	*	***
Easy of design set-up	**	*	***
Size	***	**	*
Immunity proximity effects	**	***	*

- A) *Helical* Wire coil, connected directly to pin 2, open circuit at other end. This antenna is very efficient given it's small size (20mm x 4mm dia.). The helical is a high Q antenna, trim the wire length or expand the coil for optimum results. The helical de-tunes badly with proximity to other conductive objects.
- B) *Loop* A loop of PCB track tuned by a fixed or variable capacitor to ground at the 'hot' end and fed from pin 2 at a point 20% from the ground end. Loops have high immunity to proximity de-tuning.
- C) *Whip* This is a wire, rod, PCB track or combination connected directly to pin 2 of the module. Optimum total length is 15.5cm (1/4 wave @ 433MHz). Keep the open circuit (hot) end well away from metal components to prevent serious de-tuning. Whips are ground plane sensitive and will benefit from internal 1/4 wave earthed radial(s) if the product is small and plastic cased

The antenna choice and position directly controls the system range. Keep it clear of other metal in the system, particularly the 'hot' end. The best position by far, is sticking out the top of the product. This is often not desirable for practical/ergonomic reasons thus a compromise may need to be reached. If an internal antenna must be used try to keep it away from other metal components, particularly large ones like transformers, batteries and PCB tracks/earth plane. The space around the antenna is as important as the antenna itself.

Radiometrix Ltd

Hartcran House
231 Kenton Lane
Harrow, Middlesex
HA3 8RP
ENGLAND

Tel: +44 (0) 20 8909 9595
Fax: +44 (0) 20 8909 2233
sales@radiometrix.com
www.radiometrix.com

Copyright notice

This product data sheet is the original work and copyrighted property of Radiometrix Ltd. Reproduction in whole or in part must give clear acknowledgement to the copyright owner.

Limitation of liability

The information furnished by Radiometrix Ltd is believed to be accurate and reliable. Radiometrix Ltd reserves the right to make changes or improvements in the design, specification or manufacture of its subassembly products without notice. Radiometrix Ltd does not assume any liability arising from the application or use of any product or circuit described herein, nor for any infringements of patents or other rights of third parties which may result from the use of its products. This data sheet neither states nor implies warranty of any kind, including fitness for any particular application. These radio devices may be subject to radio interference and may not function as intended if interference is present. We do NOT recommend their use for life critical applications.

The Intrastat commodity code for all our modules is: 8542 6000

R&TTE Directive

After 7 April 2001 the manufacturer can only place finished product on the market under the provisions of the R&TTE Directive. Equipment within the scope of the R&TTE Directive may demonstrate compliance to the essential requirements specified in Article 3 of the Directive, as appropriate to the particular equipment.

Further details are available on The Office of Communications (Ofcom) web site:

<http://www.ofcom.org.uk/radiocomms/ifi/>

Information Requests
Ofcom
Riverside House
2a Southwark Bridge Road
London SE1 9HA
Tel: +44 (0)845 456 3000 or 020 7981 3040
Fax: +44 (0)20 7783 4033
information.requests@ofcom.org.uk

European Radiocommunications Office (ERO)
Peblingehus
Nansensgade 19
DK 1366 Copenhagen
Tel. +45 33896300
Fax +45 33896330
ero@ero.dk
www.ero.dk