

+3.3V, 622Mbps SDH/SONET Laser Driver with Automatic Power Control

General Description

The MAX3667 is a complete, +3.3V laser driver with automatic power control (APC), designed for SDH/SONET applications up to 622Mbps. It accepts differential PECL inputs, provides single-ended bias and modulation currents, and operates over a -40°C to +85°C temperature range.

A temperature-stabilized reference voltage simplifies laser current programming. It allows external programming of the modulation current between 5mA_{P-P} and 60mA_{P-P}, and of the bias current between 5mA and 90mA.

The APC function, which incorporates a monitor photodiode, an external resistor, and two external capacitors, maintains constant laser output power. Two current monitors provide high-speed signals that are directly proportional to the bias and modulation currents. Additional features include disable/enable control and a slow-start feature with a minimum turn-on time of 50ns. The MAX3667 is available in die form and in a 32-pin TQFP package.

Applications

622Mbps SDH/SONET Access Nodes
Laser Driver Transmitters
Section Repeaters

Features

- ◆ Single +3.3V or +5.0V Operation
- ◆ Automatic Average Power Control
- ◆ Bias Current and Modulation Current Monitor Outputs
- ◆ TTL-Compatible Disable Input
- ◆ Temperature-Compensated Reference
- ◆ PECL-Compatible Data Inputs

Ordering Information

PART	TEMP RANGE	PIN-PACKAGE
MAX3667ECJ	-40°C to +85°C	32 TQFP
MAX3667E/D	-40°C to +85°C	Dice*

*Dice are designed to operate from -40°C to +85°C but are tested and guaranteed only at $T_j = +25^\circ\text{C}$.

Pin Configuration appears at end of data sheet.

Typical Operating Circuit

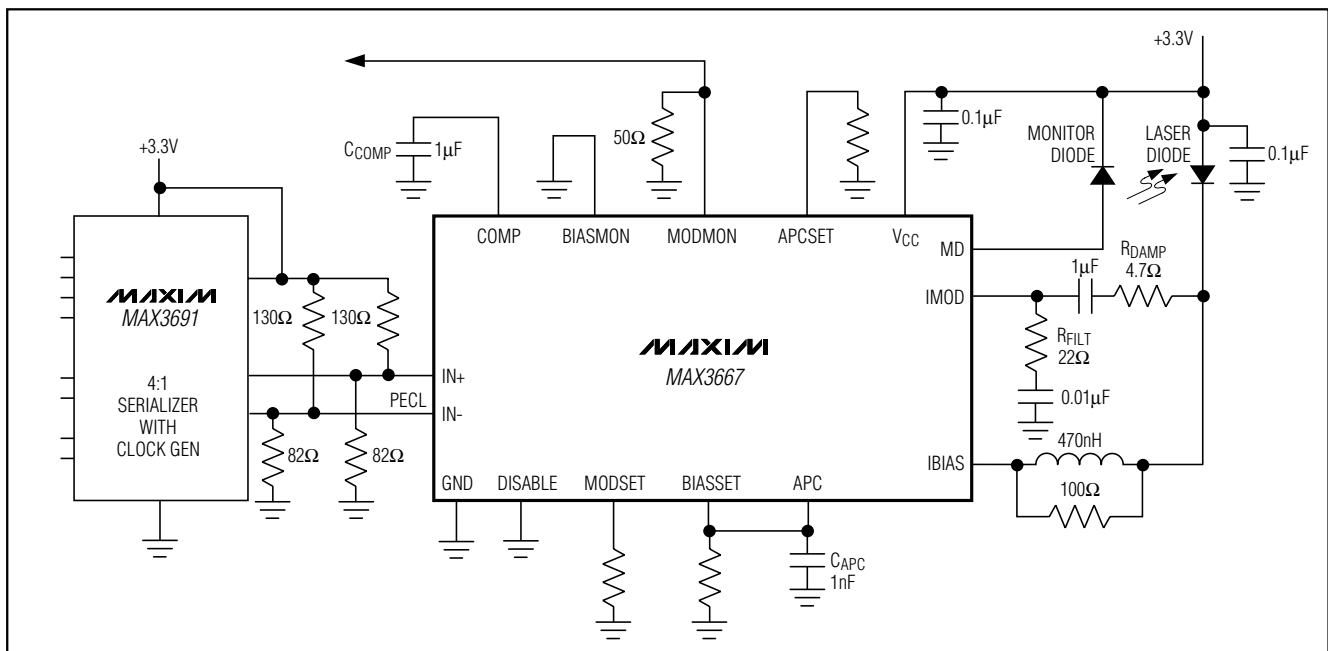

+3.3V, 622Mbps SDH/SONET Laser Driver with Automatic Power Control

ABSOLUTE MAXIMUM RATINGS

Supply Voltage, V _{CC}	-0.5V to +7.0V	Continuous Power Dissipation (T _A = +85°C)	
Current into IBIAS.....	-50mA to 350mA	TQFP (derate 11.1mW/°C above +85°C).....	721mW
Current into I _{MOD}	-50mA to 200mA	Operating Temperature Range	-40°C to +85°C
Current into MD	±7mA	Operating Junction Temperature Range (die) ..	-55°C to +175°C
Voltage at APC, MODMON, BIASMON, COMP.....	-0.5V to (V _{CC} + 0.5V)	Processing Temperature (die)	+400°C
Voltage at IN+, IN-, DISABLE, MODSET, BISASSET, APCSET, PULLUP.....	-0.5V to (V _{CC} + 0.5V)	Storage Temperature Range	-65°C to +160°C
		Lead Temperature (soldering, 10s)	+300°C

Stresses beyond those listed under "Absolute Maximum Ratings" may cause permanent damage to the device. These are stress ratings only, and functional operation of the device at these or any other conditions beyond those indicated in the operational sections of the specifications is not implied. Exposure to absolute maximum rating conditions for extended periods may affect device reliability.

DC ELECTRICAL CHARACTERISTICS

(V_{CC} = +3.3V ±5%, T_A = -40°C to +85°C, unless otherwise noted.) (Notes 1, 2)

PARAMETER	SYMBOL	CONDITIONS	MIN	TYP	MAX	UNITS
Supply Current (Note 3)	I _{CC}	Closed loop (Note 4)		112	133	mA
Bias Current Range	I _{BIAS}	(Note 5)	5		90	mA
Bias Off Current	I _{BIAS}	Disable = high		5	250	µA
Modulation Off Current	I _{BIAS}	Disable = high		20	250	µA
Internal Pullup Resistor (Note 6)	R _{PULLUP}		26	31	35	Ω
Reference Voltage (Note 7)	V _{REF}	Disable = high or low	0.91	1.01	1.11	V
Bias Current Stability		R _{BIASSET} = 2kΩ, open loop (Note 8)		500		ppm/°C
		R _{BIASSET} = 33.2kΩ, open loop (Note 8)		1000		
		R _{BIASSET} = 2kΩ, closed loop (Notes 4, 9)			480	
Modulation Current Stability		R _{MODSET} = 2kΩ, open loop (Note 8)		1100		ppm/°C
		R _{MODSET} = 33.2kΩ, open loop (Note 8)		1100		
BIASMON to IBIAS Gain	A _I	R _{BIASSET} = 2kΩ	30	38	46	A/A
MODMON to I _{QMOD} Gain	A _I	R _{MODSET} = 2kΩ (Note 10)	26	33	40	A/A
I _{BIASSET} to IBIAS Gain	A _I	R _{BIASSET} = 2kΩ	145	170	200	A/A
		R _{BIASSET} = 33.2kΩ	128	160	195	
I _{MODSET} to I _{QMOD} Gain	A _I	R _{MODSET} = 2kΩ (Note 10)	152	190	230	A/A
		R _{MODSET} = 33.2kΩ (Note 10)	152	190	230	
I _{APCSET} to IBIAS Gain	A _I	R _{APCSET} = 2kΩ	135	170	205	A/A
		R _{APCSET} = 33.2kΩ	164	205	250	
PECL Input High Voltage	V _{IH}		2.14			V
PECL Input Low Voltage	V _{IL}				1.82	V
PECL Input High Current	I _{IH}	V _{IN} = 2.14V		4.5	10	µA
PECL Input Low Current	I _{IH}	V _{IN} = 1.82V		2	10	µA
TTL Disable High Voltage	V _{DIH}		2.0			V
TTL Disable Low Voltage	V _{DIL}				0.8	V
TTL Disable High Current	I _{DIH}			1		µA
TTL Disable Low Current	I _{DIL}			4		µA

+3.3V, 622Mbps SDH/SONET Laser Driver with Automatic Power Control

MAX3667

DC ELECTRICAL CHARACTERISTICS (continued)

($V_{CC} = +5.0V \pm 5\%$, $T_A = -40^\circ C$ to $+85^\circ C$, unless otherwise noted.) (Notes 1, 2)

PARAMETER	SYMBOL	CONDITIONS	MIN	TYP	MAX	UNITS
Supply Current (Note 3)	I_{CC}	Closed loop (Note 4)		134	160	mA
Bias Off Current		Disable = high		2	250	μA
Modulation Off Current		Disable = high		32	250	μA
BIASMON to IBIAS Gain	A_I	$R_{BIASSET} = 2k\Omega$		38		A/A
MODMON to IQMOD Gain	A_I	$R_{MODSET} = 2k\Omega$ (Note 10)	26	33	40	A/A
IBIASSET to IBIAS Gain	A_I	$R_{BIASSET} = 2k\Omega$	145	180	220	A/A
		$R_{BIASSET} = 33.2k\Omega$	143	180	215	
IMODSET to IQMOD Gain	A_I	$R_{MODSET} = 2k\Omega$ (Note 10)	168	240	315	A/A
		$R_{MODSET} = 33.2k\Omega$ (Note 10)	188	230	285	
IAPCSET to IBIAS Gain	A_I	$R_{APCSET} = 2k\Omega$	132	166	200	A/A
		$R_{APCSET} = 33.2k\Omega$	145	182	220	
PECL Input High Voltage	V_{IH}		3.84			V
PECL Input Low Voltage	V_{IL}				3.52	V
PECL Input High Current	I_{IH}	$V_{IN} = 3.84V$		9		μA
PECL Input Low Current	I_{IH}	$V_{IN} = 3.52V$		8		μA

AC ELECTRICAL CHARACTERISTICS

($V_{CC} = +3.3V \pm 5\%$, $T_A = -40^\circ C$ to $+85^\circ C$, $R_{LOAD} = 10\Omega$, unless otherwise noted.) (Notes 2, 11)

PARAMETER	SYMBOL	CONDITIONS	MIN	TYP	MAX	UNITS
Modulation Current Range	I_{MOD}	$R_{FILT} = 22\Omega$, $R_{DAMP} = 0\Omega$ (Note 12)	5		60	mA
Output Rise Time	t_r	$V_{CC} = 3.3V \pm 5\%$, 20% to 80%		270	450	ps
		$V_{CC} = 5.0V \pm 5\%$, 20% to 80%		205	400	
Output Fall Time	t_f	$V_{CC} = 3.3V \pm 5\%$, 20% to 80%		425	650	ps
		$V_{CC} = 5.0V \pm 5\%$, 20% to 80%		315	600	
Output Aberrations				± 10		%
Pulse-Width Distortion	PWD	$R_{FILT} = 22\Omega$, $R_{DAMP} = 0\Omega$ (Note 13)		70		ps

Note 1: Dice are tested at $T_A = +27^\circ C$.

Note 2: Minimum voltage at IBIAS = $V_{CC} - 1.6V$.

Note 3: The sum of the currents flowing into V_{CC} and PULLUP with $R_{BIASSET} = R_{MODSET} = R_{APCSET} = 2k\Omega$, $I_{IN+} = 1.82V$, $I_{IN-} = 2.14V$.

Note 4: APC is connected to BIASSET for closed-loop operation.

Note 5: Bias current range is guaranteed by the IBIASSET to IBIAS gain test.

Note 6: RPULL-UP is connected between IMOD and PULLUP.

Note 7: V_{REF} is the voltage on BIASSET, MODSET, or APCSET with $R_{BIASSET} = R_{MODSET} = R_{APCSET} = 2k\Omega$.

Note 8: APC is disconnected from BIASSET for open-loop operation.

Note 9: Bias current stability is guaranteed by design and characterization.

Note 10: IQMOD is the current flowing into the collector of QMOD (Figure 1).

Note 11: AC parameters are guaranteed by design and characterization.

Note 12: Modulation current range is guaranteed by the IMODSET to IQMOD gain test.

Note 13: Input signal is a 155Mbps 1-0 pattern. $PWD = [(width\ of\ wider\ pulse) - (width\ of\ narrower\ pulse)] / 2$.

+3.3V, 622Mbps SDH/SONET Laser Driver with Automatic Power Control

Typical Operating Characteristics

($T_A = +25^\circ\text{C}$, $V_{CC} = +3.3\text{V}$, unless otherwise noted.)

EYE DIAGRAM
(622Mbps, 1300nm LASER,
470MHz FILTER)

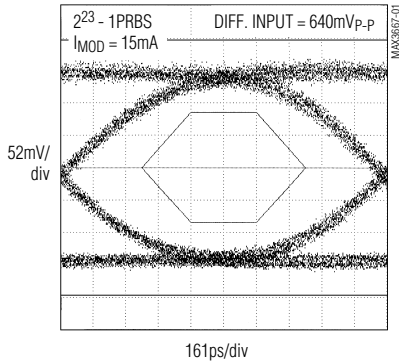

EYE DIAGRAM
(622Mbps, 10Ω LOAD)

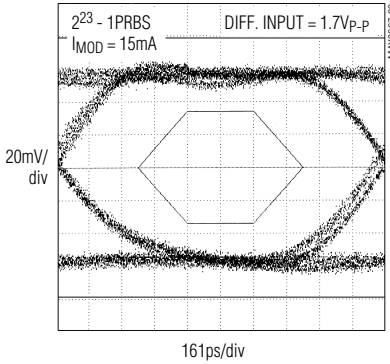

OUTPUT JITTER
(622Mbps, 10Ω LOAD)

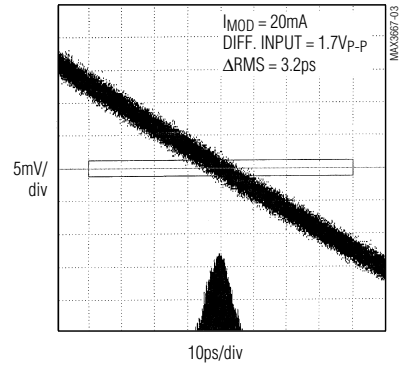

I_{BIAS} vs. R_{BIASSET}

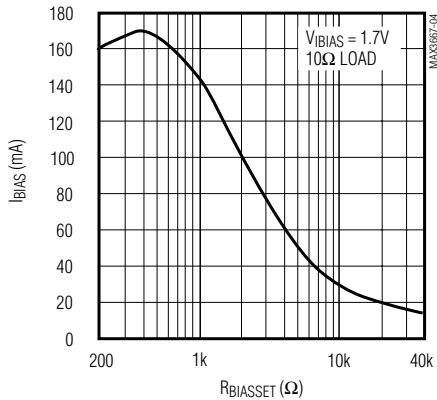

I_{QMOD} vs. R_{MODSET}

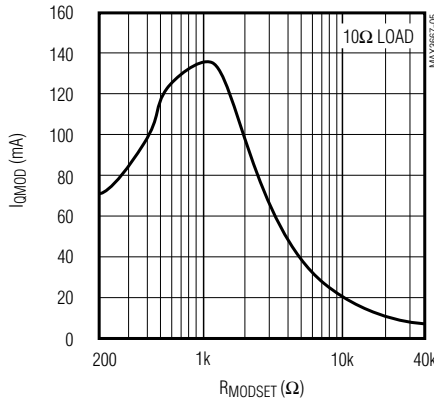

I_{MD} vs. R_{APCSET}

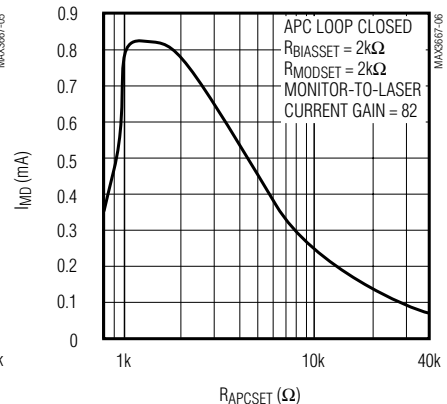

I_{BIAS} vs. R_{APCSET}
(VARYING MONITOR-TO-LASER
CURRENT GAIN)

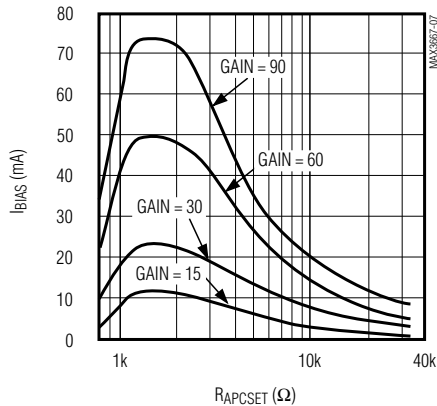

PULSE-WIDTH DISTORTION
vs. TEMPERATURE

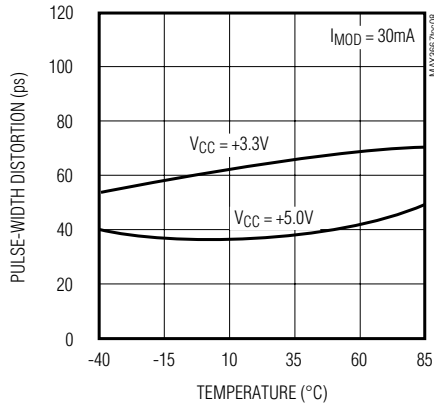

PULSE-WIDTH DISTORTION
vs. I_{MOD}

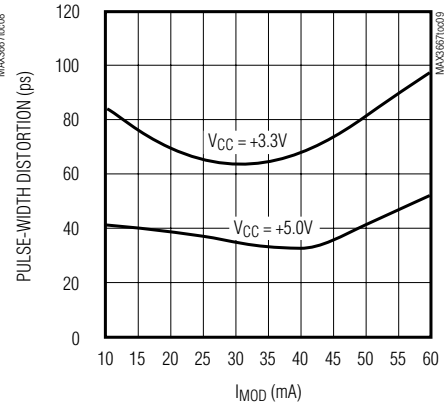

+3.3V, 622Mbps SDH/SONET Laser Driver with Automatic Power Control

MAX3667

Typical Operating Characteristics (continued)

($T_A = +25^\circ\text{C}$, $V_{CC} = +3.3\text{V}$, unless otherwise noted.)

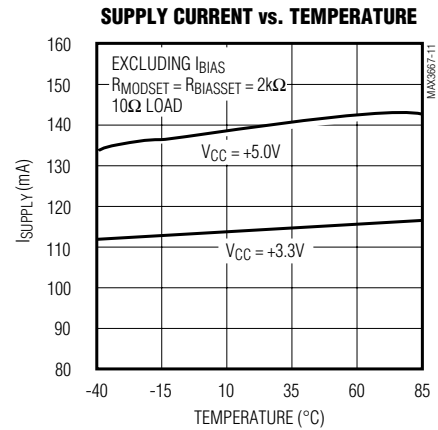
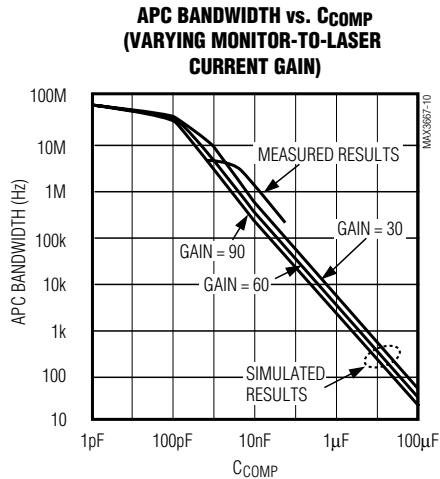

Pin Description

PIN	NAME	FUNCTION
1, 2, 23, 24	V_{CC}	Supply Voltage Input
3, 6, 8, 13, 14, 15, 18, 20, 22	GND	Ground
4	IN+	Positive PECL-Compatible Input
5	IN-	Negative PECL-Compatible Input
7	DISABLE	Disable Input. High = disable, TTL-compatible input.
9, 26, 28, 31	N.C.	No Connection
10	MODSET	Adjustment for Laser-Diode Modulation Current
11	APC	Feedback Current for Closed-Loop Laser-Diode Bias Control
12	BIASSET	Open-Loop Adjustment for Laser-Diode Bias Current
16	IBIAS	Laser-Diode DC Bias Current
17	PULLUP	V_{CC} Supply for Internal 31Ω Pullup Resistor
19, 21	IMOD	Laser-Diode Modulation Current
25	MD	Input for PIN Monitor Diode Current
27	APCSET	Closed-Loop Adjustment for Laser-Diode Bias Current
29	BIASMON	IBIAS Current Monitor (gain = $1/38 I_{BIAS}$). Open PNP collector; connect to ground if not used.
30	MODMON	IMOD Current Monitor (gain = $1/33 I_{QMOD}$). Open PNP collector; connect to ground if not used.
32	COMP	External Compensation Capacitor for Closed-Loop Laser-Diode Bias Current Control Stability

+3.3V, 622Mbps SDH/SONET Laser Driver with Automatic Power Control

Detailed Description

Low-voltage operation of laser diodes and optical transmitters produces stringent headroom conditions for laser drivers. Fast changes in modulation current produce large inductive voltage spikes, creating device saturation problems. Therefore, for +3.3V operation, the MAX3667's modulation current should be AC-coupled to the cathode of a laser diode. The recommended DC-blocking capacitor value is $1\mu\text{F}$. A simplified block diagram of the modulation driver is shown in Figure 1.

The IMOD pin is internally biased through a 31Ω pullup resistor. This design decouples the headroom associated with the modulation driver from the forward voltage drop of the laser diode, allowing the circuit to tolerate greater di/dt voltage transients. The design of the MAX3667 assumes a maximum DC forward-voltage drop of 1.6V across the laser diode. Bias current is DC-coupled to the laser diode separately at the IBIAS output. In most applications, some small amount of resistance should be added in series with the DC-blocking capacitor to help damp out the aberrations created by parasitic elements.

Automatic Power Control

The automatic power control (APC) feature allows an optical transmitter to maintain constant power, despite changes in laser efficiency due to temperature and aging. The APC loop requires the use of a PIN monitor photodiode, which generates a current proportional to the laser diode output power. A scaled version of the current flowing into the MD pin is compared to a scaled version of the current flowing out of the APCSET pin. When these currents are of equal value, the inputs of the operational transconductance amplifier (OTA) are balanced, and COMP is forced to approximately 1V.

When the average value of the monitor diode current exceeds the value established by the APCSET current, the COMP voltage is forced lower. If the average value of the monitor diode current is less than the value established by the APCSET current, the COMP node voltage is forced higher. The output of the OTA (the APC pin), when connected directly to BIASSET (closed-loop condition), is used as an error signal to adjust the bias current flowing into BIASSET. The maximum OTA output current is approximately $\pm 250\mu\text{A}$.

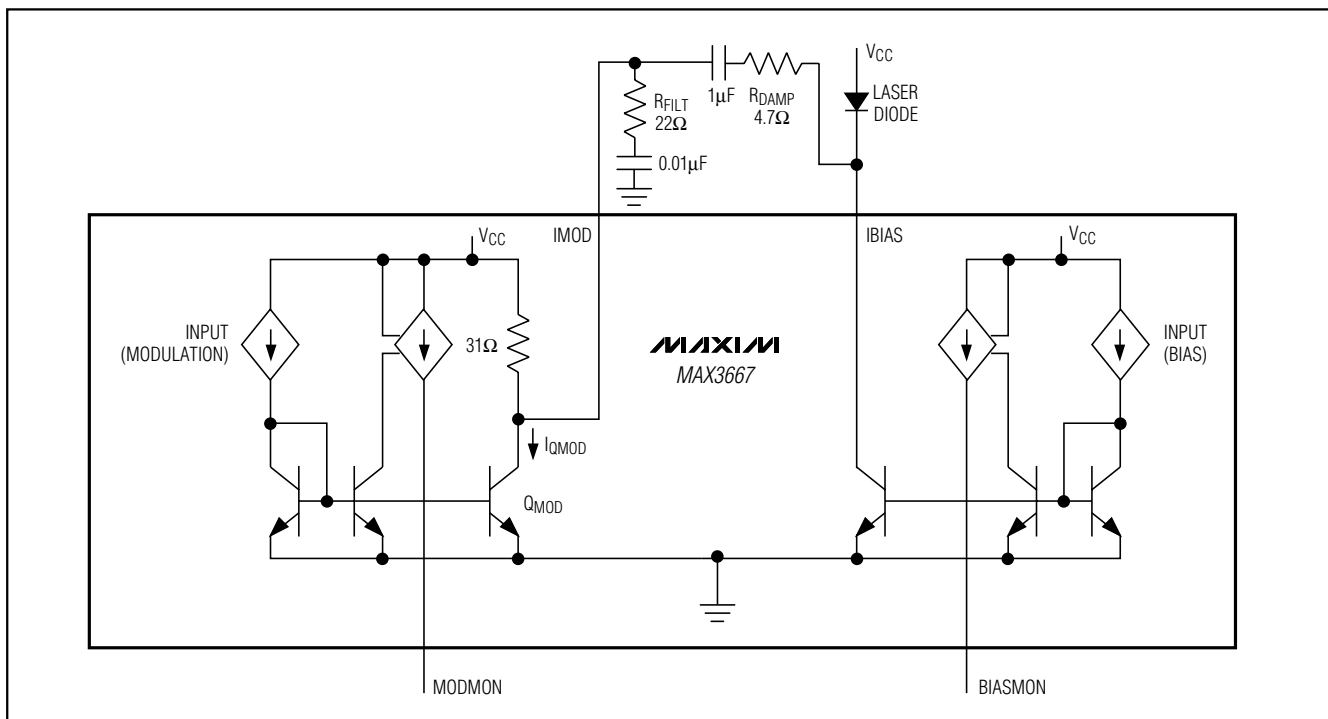

Figure 1. Simplified Modulation Driver Block Diagram

+3.3V, 622Mbps SDH/SONET Laser Driver with Automatic Power Control

bias, modulation, and monitor diode current levels. Where necessary, the reference is adjusted by a V_{BE} voltage to cancel thermal errors created by the BIASSET, MODSET, and APCSET current mirrors. This ensures that the IBIAS and IMOD currents are nearly constant over temperature with open-loop operation. With the APC loop closed, this reference helps maintain a constant average MD current (and thus a constant average laser output power) over temperature.

Bias and Modulation Current Monitors

The BIASMON and MODMON analog output monitors provide current levels that are directly proportional to the IBIAS and IMOD currents levels. These currents can be used in conjunction with other external circuitry to supervise the performance of the laser driver system without adding parasitics or reducing system performance. The gains associated with these pins, relative to IBIAS and IQMOD, are approximately 1/38 (for BIASMON) and approximately 1/33 (for MODMON).

In addition to a scaled copy of the modulation current, the MODMON current contains a DC offset current used internally to keep the driver transistors functioning at high speed, even with low modulation levels. This current is not precisely controlled and should be ignored when using the MODMON feature.

Design Procedure

Programming the Modulation Current

In addition to being a function of RMODSET, IMOD is also dependent on the values of the series damping resistor (R_{DAMP}), the shunt compensation resistance (R_{FILT}), and the resistance of the laser diode (Figure 1).

If I_{QMOD} represents the total current flowing into the collector of Q_{MOD} , then the modulation current into the laser diode can be represented by the following:

$$I_{MOD} = I_{QMOD} \left[\frac{31\Omega \parallel R_{FILT}}{31\Omega \parallel R_{FILT} + (R_{DAMP} + r_{LASER})} \right]$$

$$I_{QMOD} = (A_1)(I_{MODSET})$$

$$A_1 = I_{MODSET} \text{ to } I_{MOD} \text{ Gain}$$

Assuming $R_{FILT} = 22\Omega$, $R_{DAMP} = 4.7\Omega$, and $r_{LASER} = 4\Omega$, then this equation is simplified to:

$$I_{MOD} = I_{QMOD}(0.6)$$

For $R_{DAMP} = 4.7\Omega$, $R_{FILT} = 22\Omega$, and a laser resistance of approximately 4Ω , see the IQMOD Current vs. RMODSET graph in the *Typical Operating Characteristics* and select the value of RMODSET that corresponds to the required current at $+25^\circ\text{C}$.

Programming the Bias Current (Open Loop)

When operating the MAX3667 without APC, program the bias-current output by adjusting the BIASSET resistor. To select this resistor, determine the desired bias current required at $+25^\circ\text{C}$. Refer to the IBIAS Current vs. RBIASSET graph in the *Typical Operating Characteristics*, and select the value of RBIASSET that corresponds to the required current.

Programming the Automatic Power Control (APC)

When using the MAX3667's APC feature, program the bias-current output by adjusting the APCSET resistor. To select this resistor, determine the desired monitor current to be maintained over temperature. See the MD Current vs. RAPCSET graph in the *Typical Operating Characteristics*, and select the value of RAPCSET that corresponds to the required current.

When using the APC feature, be sure to connect the APC pin directly to BIASSET (see the *Typical Operating Circuit*). In this mode, the bias-current output level is no longer controlled by the BIASSET resistor. The APCSET resistor is now controlling the output bias level. Under closed-loop conditions, RBIASSET assures that the feedback current range is properly centered. It is recommended that RBIASSET be chosen to equal RAPCSET during closed-loop operation.

Pattern-Dependent Jitter

To reduce pattern-dependent jitter (PDJ) effects, two external compensation capacitors are required to ensure that the control loop responds slowly to changes in laser efficiency. The overall time constant of the APC loop is set by the value of these capacitors, by the transfer ratio between the laser diode current and the monitor diode current, and by the MAX3667's open-loop gain.

CCOMP must be placed between the COMP pin and ground; CAPC must be placed between the APC pin and ground (see the *Typical Operating Circuit*). For 622Mbps SDH/SONET applications, the recommended values of CCOMP and CAPC are $1\mu\text{F}$ and 1nF , respectively.

+3.3V, 622Mbps SDH/SONET Laser Driver with Automatic Power Control

MAX3667

Since the PDJ adjusts with changes in loop gain, it is important to choose capacitor values that are as large as is physically possible. Since each capacitor represents a different pole, for stability reasons, C_{APC} should be kept substantially smaller than C_{COMP} . It is recommended that the value of C_{APC} be set 1000 times smaller than C_{COMP} .

The time constant associated with the DC-blocking capacitor on IMOD can also have an effect on PDJ. It is important that this time constant produce minimum droop for long consecutive bit streams.

Referring to Figure 3, the droop resulting from long time periods without transitions can be represented by the following equation:

$$[100\% - \text{DROOP}] = e^{-\frac{t}{\tau}}$$

APC operation assures that the discharge level for τ is P_{AVG} . An overall droop of 6% relative to P_{P-P} equates to a 12% droop relative to P_{AVG} . To ensure a droop of less than 12% (6% relative to P_{P-P}), this equation can be solved for τ as follows:

$$\tau = \frac{-t}{\ln[1 - 0.12]} = 7.8t$$

If t_1 equals 100 consecutive unit intervals without a transition, then the time constant associated with the DC-blocking capacitor needs to be longer than:

$$\tau_{AC} \geq R_{ACCAC} = 7.8 (100 \text{ bits}) (1.6 \text{ ns/bit}) = 1.25 \mu\text{s}$$

The estimated value of R_{AC} is:

$$R_{AC} = 31\Omega \parallel R_{FILT} \parallel (R_{DAMP} + r_{LASER})$$

Assuming $R_{FILT} = 22\Omega$, $R_{DAMP} = 4.7\Omega$, and $r_{LASER} = 4\Omega$:

$$R_{AC} = 5.2\Omega$$

with $C_{AC} = 1\mu\text{F}$, $\tau_{AC} = 5.2\mu\text{s}$.

Operation Without APC (Open Loop)

When operating without APC, be sure to configure the MAX3667 as follows:

- 1) Disconnect APC from BIASSET.
- 2) Force a voltage of 1V to 2V at APC to prevent the OTA from saturating.
- 3) Disconnect the monitor diode.
- 4) Pull up the MD pin to V_{CC} through a $5\text{k}\Omega$ resistor.
- 5) Pull down the COMP pin to ground through a $30\text{k}\Omega$ resistor.

Remember that the bias-current output is programmed by adjusting the BIASSET resistor when the APC loop is disconnected.

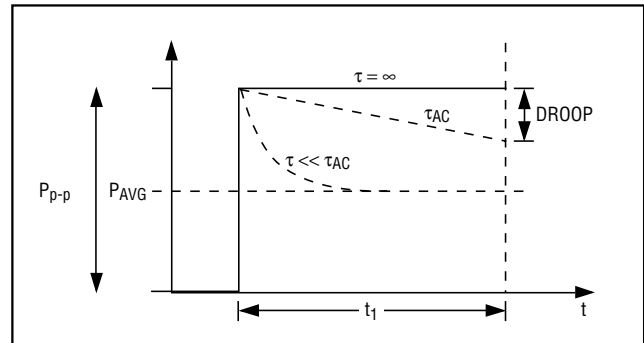

Figure 3. Droop

Output Current Limits

The MAX3667 is equipped with output current limiting and short-circuit protection. In +3.3V operation, I_{BIAS} is limited to approximately 170mA open loop, and I_{QMOD} is limited to approximately 140mA (see *Typical Operating Characteristics*). In +5.0V operation, I_{BIAS} is limited to approximately 300mA, and I_{QMOD} is limited to approximately 140mA.

If BIASSET is shorted to ground, I_{BIAS} becomes current limited. If either APCSET or MODSET is shorted to ground, the MAX3667 output is turned off. Note that, in 5V operation, the I_{BIAS} current limit is approximately 300mA. Care should be taken if the MAX3667 is being used with a laser diode that is sensitive to this current level.

Interface Suggestions and Laser Compensation

Adding damping resistance in series with the laser diode (typically 3Ω to 5Ω) raises the load resistance, reduces the load frequency dependence, and improves output aberrations. A series damping resistor of 4.7Ω is suggested for the MAX3667.

Series inductance at the cathode of the laser results in high-frequency loading ($V_L = L di/dt$) and increased output aberrations. Because of reduced headroom, the output performance of the transmitted eye diagram can be significantly impacted during 3.3V operation. Assuming that laser package series inductance can not be completely eliminated, a compensation network is required. With a laser diode load of approximately 4Ω and 4nH , a series damping resistor of 4.7Ω , and a coupling capacitor of $0.1\mu\text{F}$, a shunt R-C compensation network of 22Ω and $0.01\mu\text{F}$ is recommended (see *Typical Operating Circuit*). These values may need to be adjusted depending on the style of laser used. Note that it is important to place the compensation network as close to the load as possible.

+3.3V, 622Mbps SDH/SONET Laser Driver with Automatic Power Control

Since the IBIAS output is also connected directly to the laser cathode, any parasitic capacitance associated with this output must not be allowed to significantly load the response. To resolve this problem, place an R-L compensation network in series with the IBIAS output. The additional high-frequency impedance of this network helps maintain a high impedance at this node. The recommended values for this resistance and inductance are 100Ω and 470nH, respectively.

Optimize the laser diode performance by placing a bypass capacitor as close to the anode pin as possible. Use good high-frequency layout techniques and multilayer boards with uninterrupted ground planes.

Input Termination Requirements

The MAX3667 data inputs are PECL compatible. Standard PECL levels require 50Ω terminations to $V_{CC} - 2V$. The MAX3667's common-mode input range is 1.5V to $(V_{CC} - 0.75V)$ with a minimum differential input swing of 620mV_{P-P}. The MAX3667's inputs need not be driven with standard PECL signals; as long as the common-mode voltage and differential swing is met, the device operates properly. 50Ω input termination is also not required, but is recommended for good high-frequency termination.

Wire Bonding

For high-current density and reliable operation, the MAX3667 uses gold metalization. Make connections to the die with gold wire only, using ball-bonding techniques. Wedge bonding is not recommended. Die-pad size is 4 mils (100μm) square, and die thickness is 12 mils (300μm).

Applications Information

DC-Coupled Operation and Output Current Limits

To improve headroom conditions for the MAX3667, AC-coupling of the modulation current is required at +3.3V operation. At +5.0V operation, AC-coupling is suggested, but not required.

For AC-coupled operation, the total output current is equal to $IBIAS + IMOD / 2$. For DC-coupled modulation currents, the total output current is equal to $IBIAS + IMOD$.

Optimizing Performance for Low Modulation Currents

The MAX3667's dynamic range and headroom requirements are such that, in order to meet these specifications, low-current performance is compromised. If continual operation at low modulation currents ($\leq 20mA$) is the intended application, the MAX3667's high-frequency performance can be improved with an external pullup resistor. By shunting the AC current away from the laser diode, this technique reduces the output swing without reducing the operating current of the output transistor. Maintaining a higher modulation operating current level preserves the high-frequency performance of the output device. A suggested starting point for the external pullup resistor value is 100Ω.

Modulation Currents Greater than 60mA

At +5.0V operation, the headroom conditions for the MAX3667 are improved significantly. In this mode, it is possible to achieve modulation currents greater than 60mA by floating PULLUP and driving the laser diode directly (DC-coupled IMOD).

Laser Safety and IEC 825

Using the MAX3667 laser driver alone does not ensure that a transmitter design is compliant with IEC 825. The entire transmitter circuit and component selections must be considered. Each customer must determine the level of fault tolerance required by their application, recognizing that Maxim products are not designed or authorized for use as components in systems intended for surgical implant into the body, for applications intended to support or sustain life, or for any other application where the failure of a Maxim product could create a situation where personal injury or death may occur.

+3.3V, 622Mbps SDH/SONET Laser Driver with Automatic Power Control

Pin Configuration

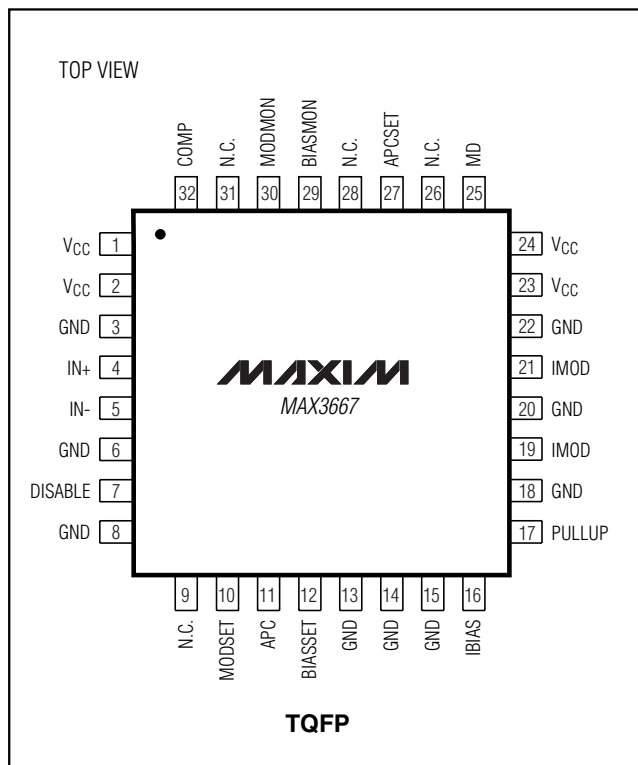

Chip Topography

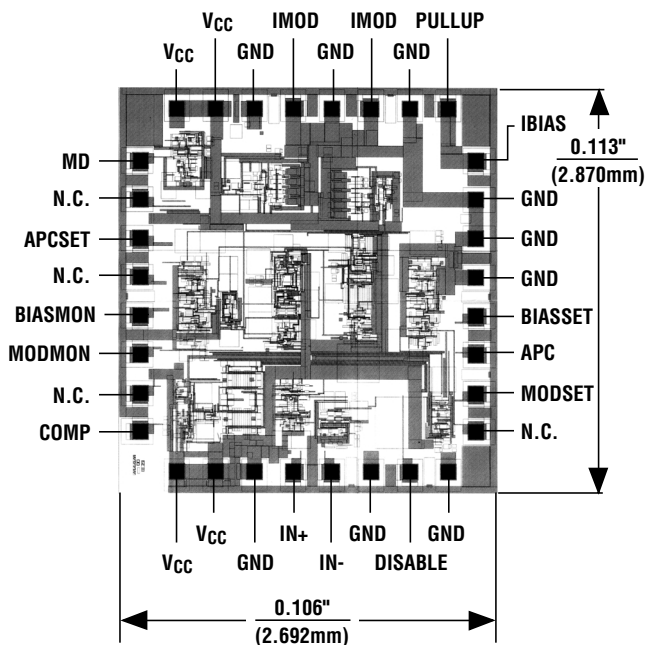

MAX3667

+3.3V, 622Mbps SDH/SONET Laser Driver with Automatic Power Control

Package Information

(The package drawing(s) in this data sheet may not reflect the most current specifications. For the latest package outline information, go to www.maxim-ic.com/packages.)

JEDEC VARIATION				
	BC		BE	
	32 LEAD		48 LEAD	
	MIN.	MAX.	MIN.	MAX.
A	---	1.60	---	1.60
A ₁	0.05	0.15	0.05	0.15
A ₂	1.35	1.45	1.35	1.45
D	8.90	9.10	8.90	9.10
D ₁	7.00	BSC.	7.00	BSC.
E	8.90	9.10	8.90	9.10
E ₁	7.00	BSC.	7.00	BSC.
e	0.8	BSC.	0.5	BSC.
L	0.45	0.75	0.45	0.75
b	0.30	0.45	0.17	0.27
c	0.09	0.20	0.09	0.20
α	0°	7°	0°	7°

NOTES:

1. ALL DIMENSIONING AND TOLERANCING CONFORM TO ANSI Y14.5-1982.
2. CONTROLLING DIMENSION: MILLIMETER.
3. THIS OUTLINE CONFORMS TO JEDEC PUBLICATION 95 REGISTRATION MO-136, VARIATIONS BC AND BE.
4. LEADS SHALL BE COPLANAR WITHIN .004 INCH.

MAXIM		
<small>PROPRIETARY INFORMATION</small>		
TITLE: PACKAGE OUTLINE, 32/48L, 7x7x1.4 MM TQFP		
APPROVAL	DOCUMENT CONTROL NO. 21-0054	REV D 1/1

32/48L, TQFP, EPS

Maxim makes no warranty, representation or guarantee regarding the suitability of its products for any particular purpose, nor does Maxim assume any liability arising out of the application or use of any product or circuit and specifically disclaims any and all liability, including without limitation consequential or incidental damages. "Typical" parameters can and do vary in different applications. All operating parameters, including "typicals" must be validated for each customer application by customer's technical experts. Maxim products are not designed, intended or authorized for use as components in systems intended for surgical implant into the body, or other applications intended to support or sustain life, or for any other application in which the failure of the Maxim product could create a situation where personal injury or death may occur.

Maxim cannot assume responsibility for use of any circuitry other than circuitry entirely embodied in a Maxim product. No circuit patent licenses are implied. Maxim reserves the right to change the circuitry and specifications without notice at any time.

12 Maxim Integrated Products, 120 San Gabriel Drive, Sunnyvale, CA 94086 (408) 737-7600