

PRODUCT OVERVIEW

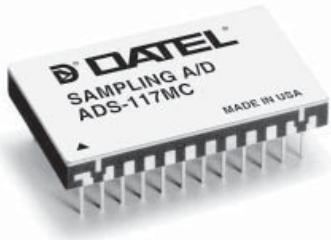

DATEL's ADS-117 is a functionally complete, 12-bit, 2MHz, sampling A/D converter. Its standard, 24-pin, double-width DIP contains a fast-settling sample-hold amplifier, a 12-bit subranging (two-step) A/D converter, a precision reference, three-state output register and all the timing and control logic necessary to operate from a single start convert pulse. Digital input and output levels are TTL.

Total harmonic distortion (THD) and signal-to-noise ratio (including distortion) typically run -78dB and 70dB , respectively, with full scale inputs up to 100kHz . The ADS-117 requires $\pm 15\text{V}$ and $+5\text{V}$ power supplies and typically consumes 1.6 Watts . Models are available for use in either commercial (0 to $+70^\circ\text{C}$) or military (-55 to $+125^\circ\text{C}$) operating temperature ranges and extended commercial (-40 to $+85^\circ\text{C}$).

FEATURES

- 12-bit resolution
- No missing codes
- 2MHz minimum throughput
- Functionally complete
- Small 24-pin DDIP
- Low-power, 1.6 Watts
- Three-state output buffers
- Samples to Nyquist frequencies

INPUT/OUTPUT CONNECTIONS			
PIN	FUNCTION	PIN	FUNCTION
1	BIT 12 (LSB)	24	-15V Supply
2	BIT 11	23	ANALOG GROUND
3	BIT 10	22	$+15\text{V}$ SUPPLY
4	BIT 9	21	$+10\text{V}$ REFERENCE
5	BIT 8	20	BIPOLAR
6	BIT 7	19	ANALOG INPUT
7	BIT 6	18	COMP BIN
8	BIT 5	17	ENABLE (1-12)
9	BIT 4	16	START CONVERT
10	BIT 3	15	EOC
11	BIT 2	14	DIGITAL GROUND
12	BIT 1 (MSB)	13	$+5\text{V}$ SUPPLY

BLOCK DIAGRAM

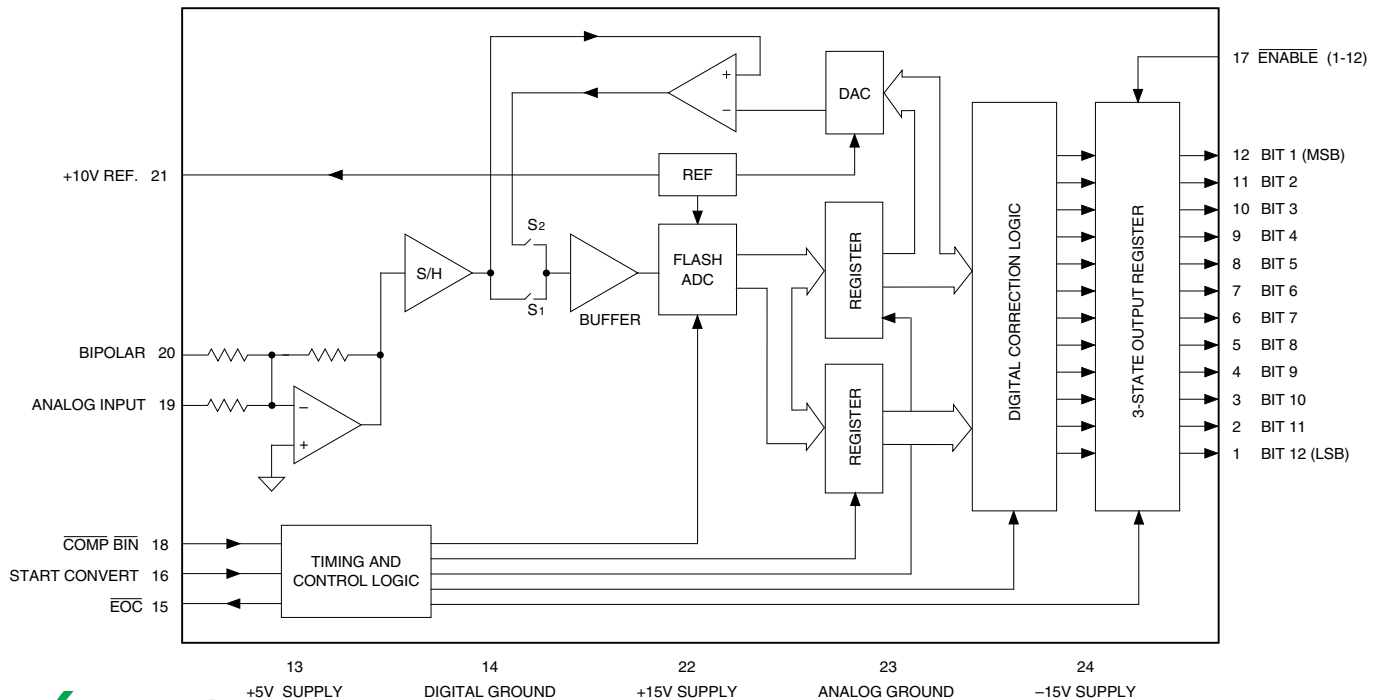

Figure 1. ADS-117 Functional Block Diagram



ABSOLUTE MAXIMUM RATINGS		
PARAMETERS	LIMITS	UNITS
+15V Supply (Pin 22)	0 to +16	Volts
-15V Supply (Pin 24)	0 to -16	Volts
+5V Supply (Pin 13)	0 to +6.0	Volts
Digital Inputs (Pin 16, 17, 18)	-0.3 to +V _{DD} +0.3	Volts
Analog Input (Pin 19)	-9 to +15	Volts
Lead Temp. (10 seconds)	+300	°C

FUNCTIONAL SPECIFICATIONS

(T_A = +25°C, ±V_{CC} = +15V, +V_{DD} = +5V, 2MHz sampling rate, and a minimum 3 minute warmup unless otherwise specified.)

ANALOG INPUTS	MIN.	TYP.	MAX.	UNITS
Input Voltage Range ①				
Bipolar	—	±5	—	Volts
Unipolar	—	0 to +10	—	Volts
Input Impedance	4.5	5	—	kΩ
Input Capacitance	—	6	15	pF

DIGITAL INPUTS				
Logic Levels				
Logic "1"	+2.0	—	—	Volts
Logic "0"	—	—	+0.8	Volts
Logic Loading "1"	—	—	+5	μA
Logic Loading "0"	—	—	-600	μA

PERFORMANCE				
Resolution	12 Bits			
No Missing Codes (12 Bits; f _{in} = 1MHz)	0 to +70°C			
Integral Non-Linearity				
0 to +70°C	—	±1/2	±3	LSB
-55 to +125°C	—	±1	±4	LSB
Differential Non-Linearity				
0 to +70°C	—	±1/2	±0.95	LSB
-55 to +125°C / -45 to +85°C	—	±1	+1.5	LSB
Full Scale Absolute Accuracy (see Tech Note 1)				
0 to +70°C	—	±0.13	±0.44	%FSR
-55 to +125°C / -45 to +85°C	—	±0.25	±0.73	%FSR
Unipolar/Bipolar Zero Error				
0 to +70°C (see Tech Note 1)	—	±0.07	±0.38	%FSR
-55 to +125°C / -45 to +85°C	—	±0.22	±0.73	%FSR
Bipolar Offset Error				
0 to +70°C (see Tech Note 1)	—	±0.1	±0.38	%FSR
-55 to +125°C / -45 to +85°C	—	±0.53	±0.73	%FSR
Gain Error (see Tech Note 1)				
0 to +70°C	—	±0.1	±0.38	%
-55 to +125°C / -45 to +85°C	—	±0.53	±0.73	%
Internal Reference Voltage				
0 to +70°C	+9.97	+10.0	+10.03	Volts
-55 to +125°C / -45 to +85°C	+9.95	—	+10.05	Volts
External Current	—	—	1.5	mA

DYNAMIC PERFORMANCE				
Spurious Free Dynamic Range (-0.5dB) ②				
dc to 100kHz	—	-81	—	dB
100kHz to 500kHz	—	-75	-70	dB
500kHz to 1MHz	—	-70	—	dB
Total Harm. Distort. (-0.5dB)				
dc to 100kHz	—	-78	—	dB
100kHz to 500kHz	—	-73	-68	dB
500kHz to 1MHz	—	-71	—	dB

① See Table 1 also

② Same specifications for in-band harmonics.

DYNAMIC PERF. (cont)	MIN.	TYP.	MAX.	UNITS
Input Bandwidth (-3dB)				
Small Signal (-20dB input)	8	10	—	MHz
Large Signal (-0.5dB input)	7	9	—	MHz
Feedthrough (1MHz)	-72	-74	—	dB
SNR (wo/distortion, -0.5dB)				
dc to 100kHz	—	72	—	dB
0 to +70°C	—	72	—	dB
-55 to +125°C / -45 to +85°C	—	72	—	dB
100kHz to 500kHz				
0 to +70°C	65	70	—	dB
-55 to +125°C / -45 to +85°C	65	70	—	dB
500kHz to 1MHz				
0 to +70°C	—	70	—	dB
-55 to +125°C / -45 to +85°C	—	70	—	dB
SNR (and distort., -0.5dB) ③				
dc to 100kHz	—	70	—	dB
0 to +70°C	—	70	—	dB
-55 to +125°C / -45 to +85°C	—	69	—	dB
100kHz to 500kHz				
0 to +70°C	64	70	—	dB
-55 to +125°C / -45 to +85°C	62	69	—	dB
500kHz to 1MHz				
0 to +70°C	—	69	—	dB
-55 to +125°C / -45 to +85°C	—	69	—	dB

Two-tone Intermodulation Distortion (f _{in} = 970kHz, 990kHz, f _s = 2MHz, -0.5dB)	—	-68	—	dB
Slew Rate	—	±210	—	V/μs
Effect. Aperture Delay Time	—	—	16	ns
Overvoltage Recovery Time; 20%	—	—	500	ns
S/H Acq. Time , (to ±0.01%)				
0 to +70°C	—	155	165	ns
-55 to +125°C / -45 to +85°C	—	160	170	ns
Conversion Rate	2	—	—	MHz

OUTPUTS				
Output Coding	Straight binary/Offset binary			
Pin 18 High	Complementary binary			
Pin 18 Low	Complementary offset binary			
Logic Level				
Logic "1"	+2.4	—	—	Volts
Logic "0"	—	—	+0.4	Volts
Logic Loading "1"	—	—	-160	μA
Logic Loading "0"	—	—	+6.4	mA

POWER REQUIREMENTS				
Power Supply Ranges ④				
+15V Supply	+14.25	+15.0	+15.75	Volts
-15V Supply	-14.25	-15.0	-15.75	Volts
+5V Supply	+4.75	+5.0	+5.25	Volts
Power Supply Current				
+15V Supply	—	+48	+58	mA
-15V Supply	—	-35	-45	mA
+5V Supply	—	+75	+85	mA
Power Dissipation	—	1.6	1.9	Watts
Power Supply Rejection	—	—	±0.07	%FSR%/V

③ Effective bits is equal to:

$$(\text{SNR} + \text{Distortion}) - 1.76 + \left[20 \log \frac{\text{Full Scale Amplitude}}{\text{Actual Input Amplitude}} \right]$$

6.02

④ For ±12V, +5V operation, contact Murata Power Solutions.

FUNCTIONAL SPECIFICATIONS. CONT.

PHYSICAL/ENVIRONMENTAL				
Operating Temp. Range, Case				
ADS-117MC	0	—	+70	°C
ADS-117ME	-45	—	+85	°C
ADS-117MM, 883	-55	—	+125	°C
Storage Temperature Range				
	-65	—	+150	°C
Thermal Impedance				
θ_{jc}	—	3	—	°C/W
θ_{ca}	—	23	—	°C/W
Package Type				
	24-pin, metal-sealed, ceramic DDIP			
Weight				
	0.42 ounces (12 grams)			

TECHNICAL NOTES

- Applications which are unaffected by endpoint errors or remove them through software will use the typical connections shown in Figure 3. Remove system errors or adjust the small initial errors of the ADS-117 to zero using the optional external circuitry shown in Figure 4. The external adjustment circuit has no effect on the throughput rate.
- Always connect the analog and digital grounds to a ground plane beneath the converter for best performance. The analog and digital grounds are not connected to each other internally.
- Bypass the analog and digital supplies and the +10V reference (pin 21) to ground with 4.7µF, 25V tantalum electrolytic capacitors in parallel with 0.1µF ceramic capacitors. Bypass the +10V reference (pin 21) to ANALOG GROUND (pin 23).
- Obtain straight binary/offset binary output coding by tying $\overline{\text{COMP BIN}}$ (pin 18) to +5V or leaving it open. The device has an internal pull-up resistor on this pin. To obtain complementary binary or complementary offset binary output coding, tie pin 18 to ground. The pin 18 signal is compatible with CMOS/TTL logic levels for those users desiring dynamic control of this function. Do not change $\overline{\text{COMP BIN}}$ status while $\overline{\text{EOC}}$ is high.
- To enable the three-state outputs, connect $\overline{\text{ENABLE}}$ (pin 17) to a logic "0" (low). To disable, connect pin 17 to a logic "1" (high).
- To meet the guaranteed conversion rate, a maximum start convert pulse is specified. A wider start convert pulse will result in slower conversion rates. An initial start convert pulse is required before performing an actual conversion after power-up to assure the sample-hold is in the acquisition mode.
- Re-initiating the START CONVERT (pin 16) while $\overline{\text{EOC}}$ is a logic "1" (high) will result in a new conversion sequence.

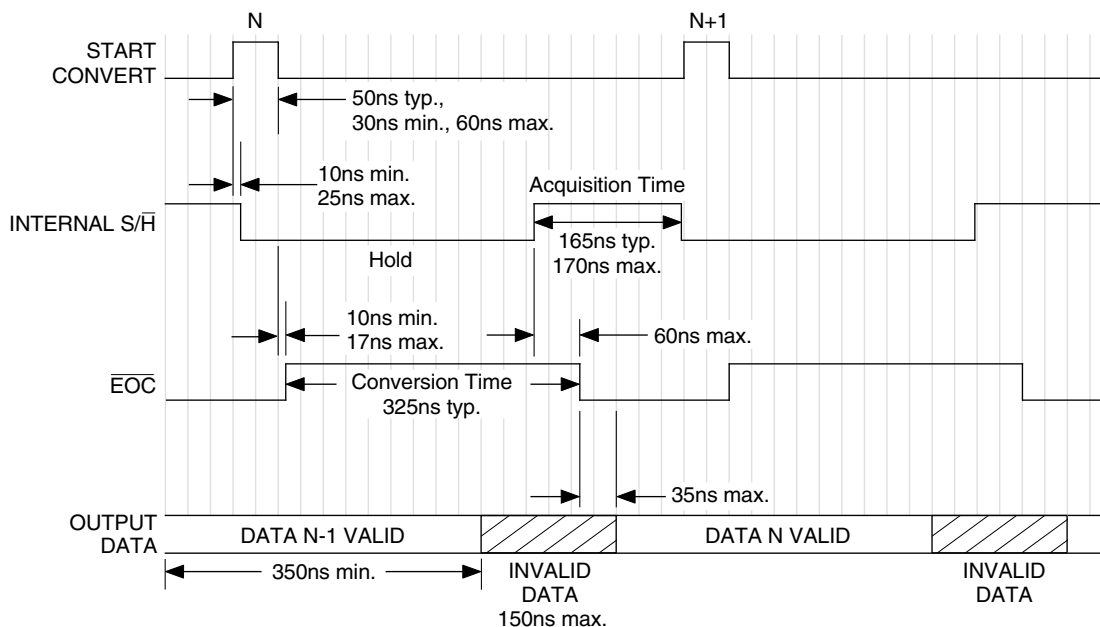

Note: Scale is approximately 25ns per division.

Figure 2. ADS-117 Timing Diagram

CALIBRATION PROCEDURE

1. Connect the converter per Figure 3, Figure 4, and Table 1 for the appropriate input range. Apply a pulse of 150 nanoseconds to the START CONVERT input (pin 16) at a rate of 250kHz. This rate is chosen to reduce flicker if LED's are used on the outputs for calibration purposes.

2. Zero Adjustments

Apply a precision voltage reference source between the amplifier's analog input and ground. Adjust the output of the reference source per Table 2. For unipolar, adjust the zero trimming potentiometer so that the output code flickers equally between 0000 0000 0000 and 0000 0000 0001 with the pin 18 tied high (straight binary) or between 1111 1111 1111 and 1111 1111 1110 with the pin 18 tied low (complementary binary).

For bipolar operation, adjust the potentiometer such that the code flickers equally between 1000 0000 0000 and 1000 0000 0001 with pin 18 tied high (offset binary) or between 0111 1111 1111 and 0111 1111 1110 with pin 18 tied low (complementary offset binary).

3. Full-Scale Adjustment

Set the output of the voltage reference used in step 2 to the value shown in Table 1. Adjust the gain trimming potentiometer so that the output code flickers equally between 1111 1111 1110 and 1111 1111 1111 for pin 18 tied high or between 0000 0000 0001 and 0000 0000 0000 for pin 18 tied low.

4. To confirm proper operation of the device, vary the precision reference voltage source to obtain the output coding listed in Table 3.

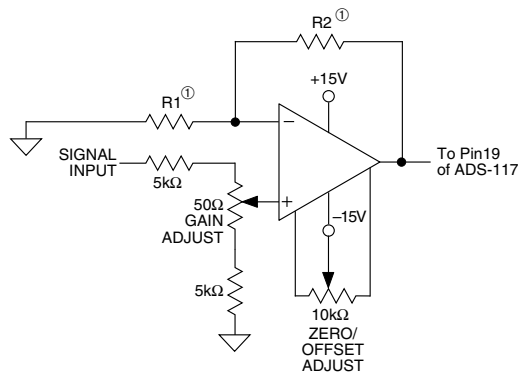

① For values of R1 and R2 refer to Table 1.

Figure 4. Optional Calibration Circuit

Table 1. Input Connections (using external calibration)

INPUT RANGE	R1	R2	UNIT
0 to +10V, ±5	2	2	kΩ
0 to 5V, ±2.5V	2	6	kΩ
0 to +2.5V, ±1.25V	2	14	kΩ

Table 2. Zero and Gain Adjustments

INPUT RANGE	ZERO ADJUST +1/2 LSB	GAIN ADJUST RANGE
0 to +10V	+1.22mV	+9.9963V
±5V	+1.22mV	+4.9963V

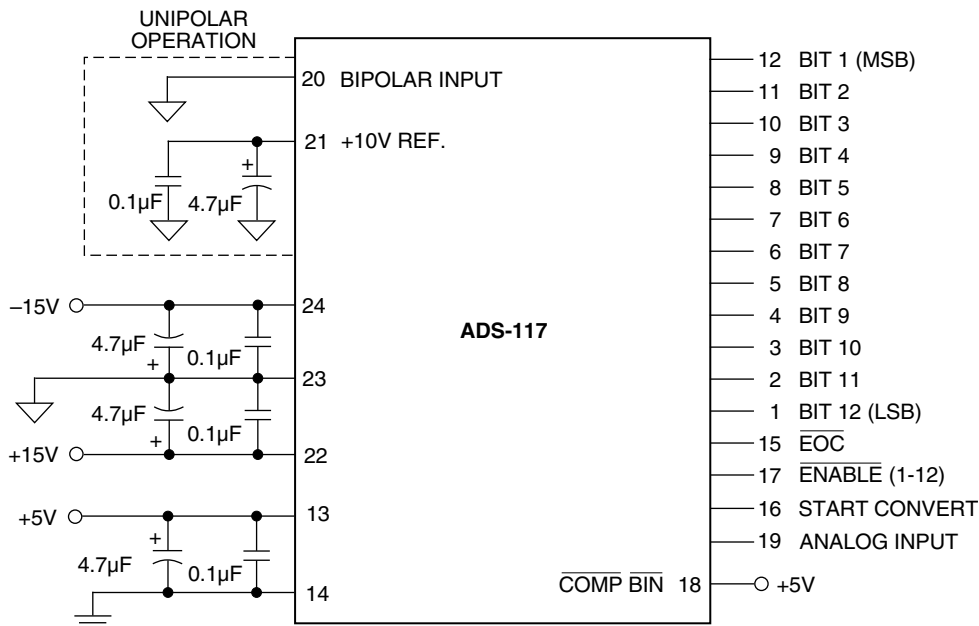

NOTE: For unipolar operation, ground pin 20.
For bipolar operation, connect pin 20 to pin 21.
Always bypass pin 21 as shown for both unipolar and bipolar operation.

Figure 3. ADS-117 Connection Diagram

Table 3. Output Coding

UNIPOLAR SCALE	INPUT RANGE 0 to +10V	STRAIGHT BIN.			COMP. BINARY			INPUT RANGE ±5V	BIPOLAR SCALE
		OUTPUT CODING							
		MSB	LSB		MSB	LSB			
+FS - 1 LSB	+9.9976	1111	1111	1111	0000	0000	0000	+4.9976	+FS - 1 LSB
+7/8 FS	+8.7500	1110	0000	0000	0001	1111	1111	+3.7500	+3/4FS
+3/4 FS	+7.5000	1100	0000	0000	0011	1111	1111	+2.5000	+1/2FS
+1/2 FS	+5.0000	1000	0000	0000	0111	1111	1111	0.0000	0
+1/4 FS	+2.5000	0100	0000	0000	1011	1111	1111	-2.5000	-1/2FS
+1/8 FS	+1.2500	0010	0000	0000	1101	1111	1111	-3.7500	-3/4FS
+1 LSB	+0.0024	0000	0000	0001	1111	1111	1110	-4.9976	-FS+1LSB
0	0.0000	0000	0000	0000	1111	1111	1111	-5.0000	-FS

OFF. BINARY COMP. OFF. BIN.

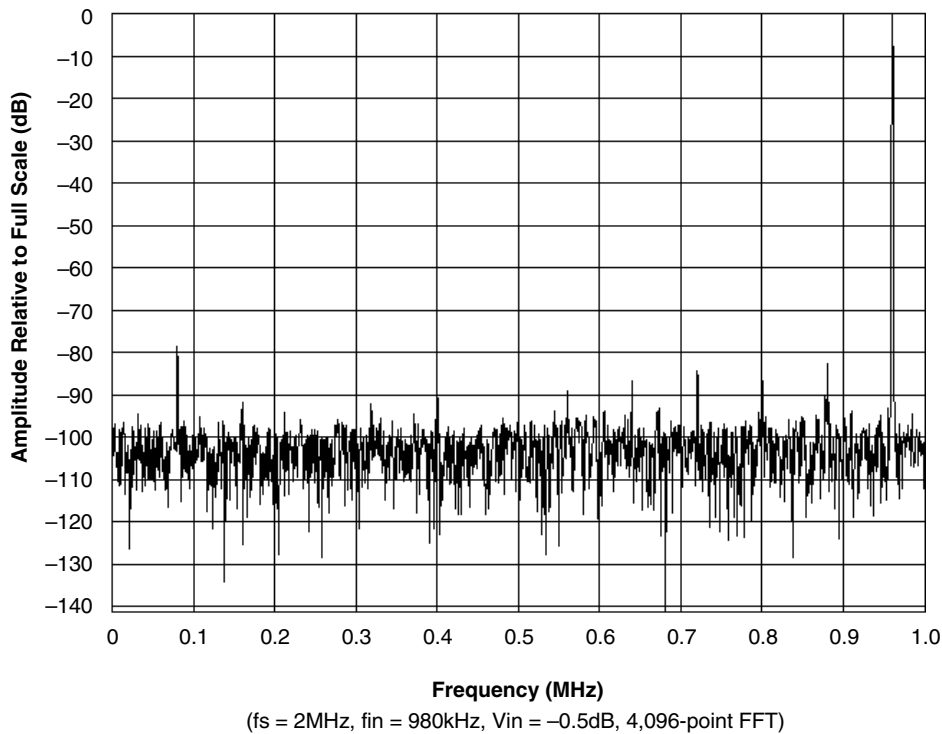
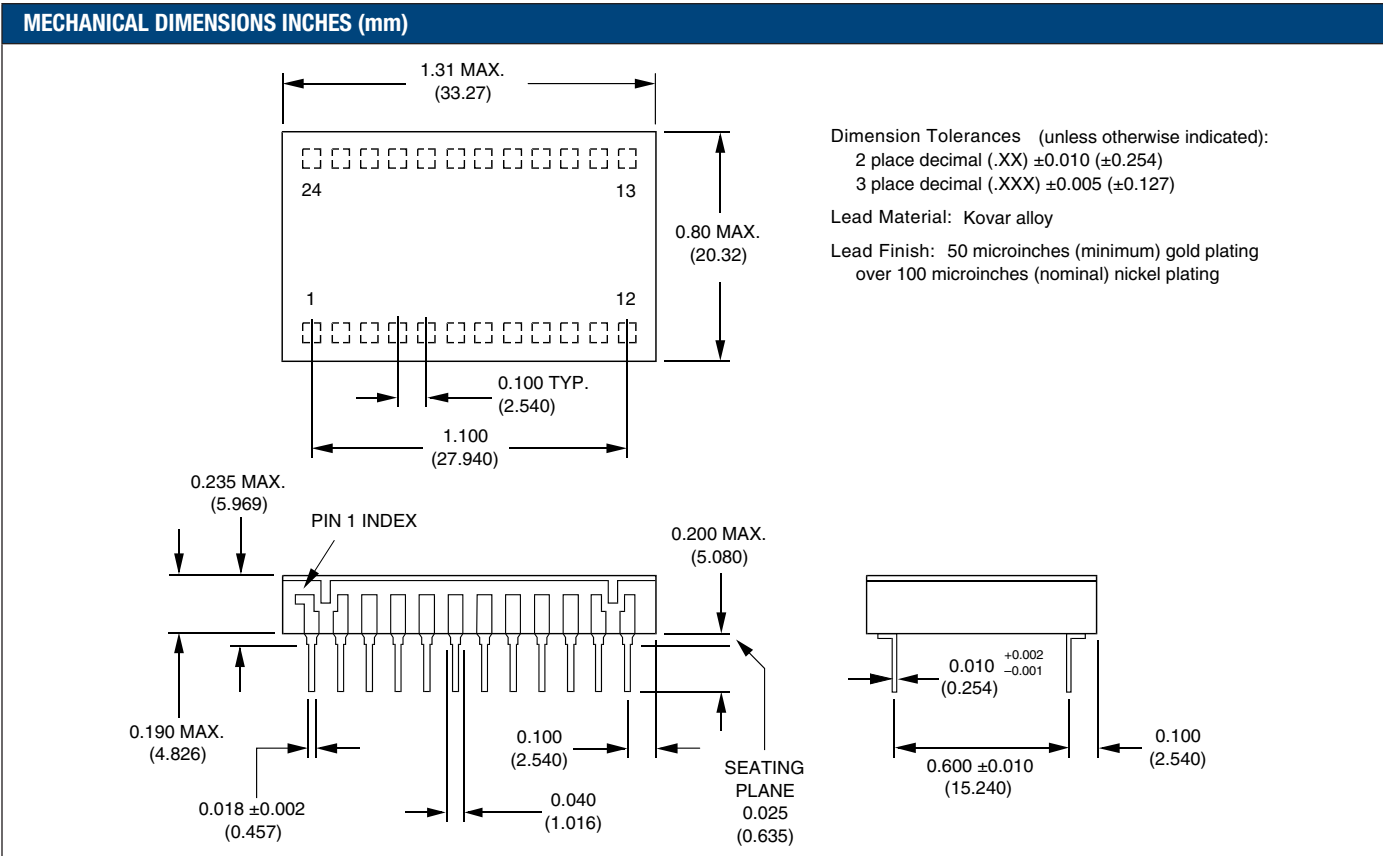

Figure 5. FFT Analysis of ADS-117



ORDERING INFORMATION

MODEL NUMBER	OPERATING TEMP. RANGE	ACCESSORIES
ADS-117MC	0 to +70°C	ADS-EVAL1 Evaluation Board (without ADS-117)
ADS-117ME	-40 to +85°C	HS-24 Heat Sink for all ADS-117 models
ADS-117MM	-55 to +125°C	
ADS-117/883	-55 to +125°C	

For MIL-STD-883 product specification or availability of surface-mount packaging, contact DATEL. Receptacles for PC mounting can be ordered through AMP Inc., Part # 3-331272-8 (Component Lead Socket), 24 required.