

DATA SHEET

10GBPS 850NM VCSEL LC TOSA PACKAGE SFP+ APPLICATIONS

HFE6192-X61

FEATURES:

- HFE6192-261 normal polarity
- HFE6192-361 inverted polarity
- High performance VCSEL
- Low electrical parasitic TO package with flexible interface
- Data rates from DC to 12.5Gbps
- Differential, Cathode or Anode driven versions available
- Complete isolation between the VCSEL, Monitor Photodiode and Case
- Mechanically compatible with all 10Gbps MSAs

The HFE6192-x61 uses a high-performance Vertical Cavity Surface Emitting Laser (VCSEL) designed to meet performance requirements for 10Gbps data communication over multimode optical fiber. Applications include Ethernet, Fibre Channel and ATM protocols. The optical assembly is designed to interface either 50 μ m or 62.5 μ m multimode fiber and ensure launch conditioning requirements compatibility with enhanced bandwidth fiber as specified by TIA 455-203.

The HFE6192-x61 incorporates a power monitoring photodiode that can be used for temperature compensation, average power control, and for compliance with Class 1 eye safety limits.



LC TOSA

Part Number	Description
HFE6192-261	SFP+ 10Gb Differentially Driven, attenuated, LC TOSA, with 50 Ω flex, normal pin polarity
HFE6192-361	SFP+ 10Gb Differentially Driven, attenuated, LC TOSA, with 50 Ω flex, inverted pin polarity

ABSOLUTE MAXIMUM RATINGS

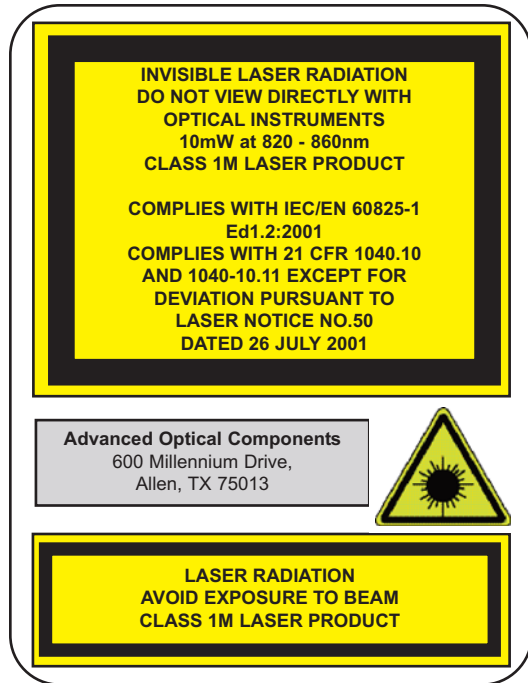

Parameter	Rating
Storage temperature	-40°C to +85°C
Case operating temperature	0 to +85°C
Lead solder temperature	260°C, 10 seconds
Reverse Power Supply Voltage	5V
Peak continuous forward current	12mA
ESD Exposure (Human Body Model)	150V

NOTICE: Stresses greater than those listed under “Absolute Maximum Ratings” may cause permanent damage to the device. This is a stress rating only and functional operation of the device at these or any other conditions above those indicated in the operations section for extended periods of time may affect reliability.

NOTICE: The inherent design of this component causes it to be sensitive to electrostatic discharge (ESD). To prevent ESD-induced damage and/or degradation to equipment, take normal ESD precautions when handling this product

ELECTRICAL-OPTICAL CHARACTERISTICS

$T_A = 25^\circ\text{C}$ unless otherwise stated

VCSEL Parameters	Test Condition	Symbol	Min.	Typ.	Max.	Units	Notes
Fiber coupled optical power	$I_F = 6.5\text{mA}$ peak 50/125 μm fiber	P_{OC}	400	600		μW	
Coupling Efficiency	$I_F = 6.5\text{mA}$	PO_PCT	70			%	1
Threshold Current		I_{TH}		1	2	mA	
Threshold Current Temperature Variation	$T_A = 0$ to 70°C	ΔI_{TH}			1	mA	2
Slope Efficiency	$P_{OC} = 0.6\text{mW}$	η	0.05	0.075	0.2	mW/mA	3
Slope Efficiency Temperature Variation	$T_A = 0$ to 70°C	$\Delta\eta/\Delta T$		-0.4		%/ $^\circ\text{C}$	
Peak Wavelength	$I_F = 6.5\text{mA}$	λ_p	840		860	nm	
λ_p Temperature Variation	$T_A = 0$ to 70°C	$\Delta\lambda_p/\Delta T$		0.06		nm/ $^\circ\text{C}$	
RMS Spectral Bandwidth	$I_F = 6.5\text{mA}$	$\Delta\lambda$			0.4	nm	
Laser Forward Voltage	$I_F = 6.5\text{mA}$	V_F	1.6	1.8	2.4	V	
Laser Reverse Voltage	$I_R = 10\mu\text{A}$	V_R	5	10		V	
Rise/Fall Time	Bias above threshold 20%-80%	T_R T_F			40 40	ps	4
Relative Intensity Noise	$I_F = 6.5\text{mA}$	RIN_{12}			-130	dB/Hz	5
Series Resistance	$I_F = 6.5\text{mA}$	R	41	60	75	Ohms	
Series Resistance Temperature Variation	$I_F = 6.5\text{mA}$	$\Delta R/\Delta T$		-0.2		%/ $^\circ\text{C}$	
Total Capacitance	$I_F = 6.5\text{mA}$	C_T			0.5	pF	6
Encircled Flux Diameter	$I_F(\text{avg}) = 6.5\text{mA}$	EF					7

Photodiode Parameters	Test Condition	Symbol	Min.	Typ.	Max.	Units	Notes
Monitor Current	$P_{OC} = 0.6\text{mW}$, $V_R = 3\text{V}$	I_{PD}	50	150	300	μA	
Monitor Current Temperature Variation	$P_{OC} = 0.6\text{mW}$ $T_A = 0$ to 70°C	$\Delta I_{pd}/\Delta T$		0.0		%/ $^\circ\text{C}$	
Tracking Ratio Variation (Open Bore)	$P_{OB} = -2.5\text{dBm}$ $T_A = 0$ to 70°C	ΔTR	-0.5		+0.5	dB	
Dark Current	$P_{OC} = 0\text{mW}$, $V_R = 3\text{V}$	I_{DARK}			20	nA	
PD Reverse Voltage	$P_{OC} = 0\text{mW}$, $I_R = 10\mu\text{A}$	BVR_{PD}	30	115		V	8
PD Capacitance	$V_R = 0\text{V}$, Freq=1MHz $V_R = 3\text{V}$, Freq=1MHz	C_{PD}		75 40	100 55	pF	

NOTES

1. PO_PCT is defined as the ratio of the coupled power into a 50/125 micron fiber to the total power output from the optical front end as measured on a large area detector.
2. Operation outside of the specified range may result in the threshold current exceeding the maximums defined in the electro-optical characteristics table. ΔI_{TH} is the maximum deviation from the 25°C value.
3. Slope efficiency is defined as $\Delta P_O / \Delta I_F$ at a total power output of 0.6mW. Slope efficiency is intentionally lowered to the value shown by attenuation.
4. Rise and fall times are sensitive to drive electronics. Rise and fall times are measured 20%-80% using a 1GHz square wave AC coupled to the VCSEL using a bias-T. The DC current is adjusted to achieve a minimum OMA of -4dBm. Corrections are made for finite detector bandwidth.
5. RIN_{12} is measured using the OMA technique with 12dB return.
6. Total capacitance is measured with the VCSEL forward biased using a Network analyzer at 1GHz.
7. Encircled flux is measured per TIA-455-203.
8. To prevent VCSEL damage, short the VCSEL anode and cathode during BVR testing of the photodiode.

PINOUT

Number	HFE6192-261	HFE6192-361
1	PDK	PDK
2	GND	GND
3	LDA	LDK
4	LDK	LDA
5	GND	GND
6	PDA	PDA

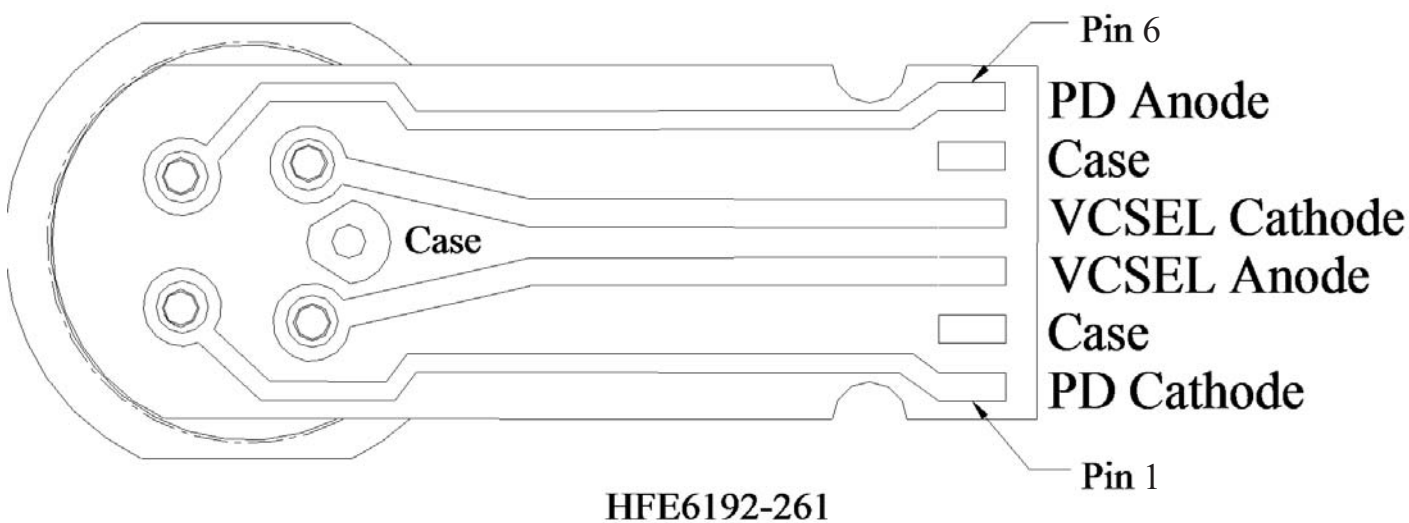

MOUNTING DIMENSIONS - LC TOSA WITH FLEX

Dimensions in inches

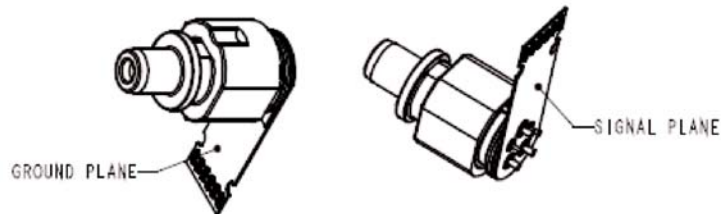
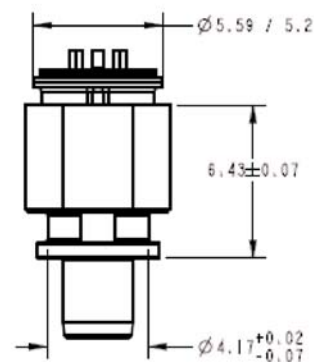
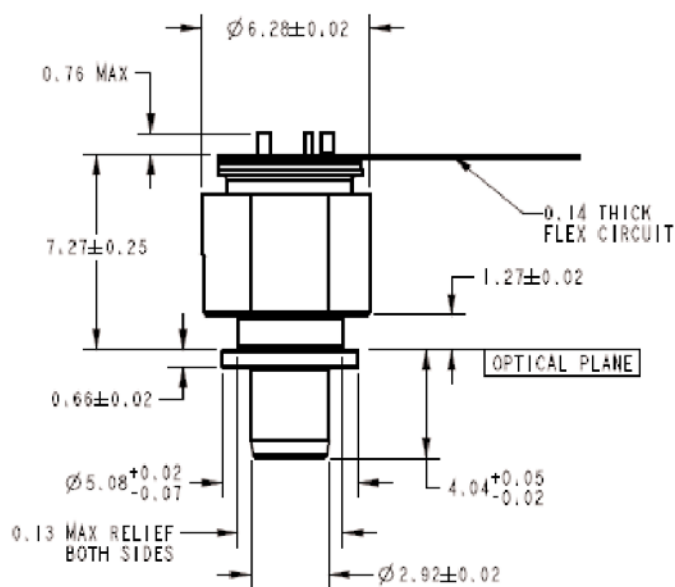
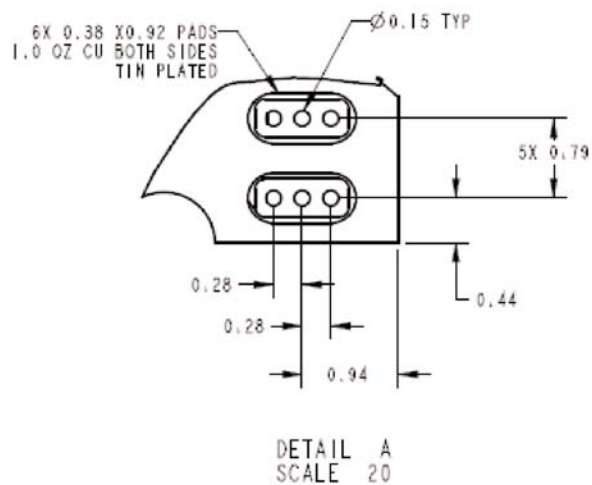
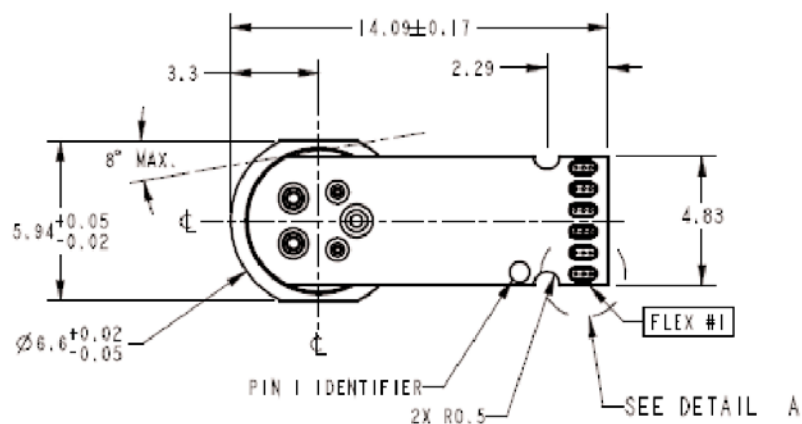

TYPICAL PERFORMANCE CURVES

RMS Spectral Width is defined and measured using TIA-455-127

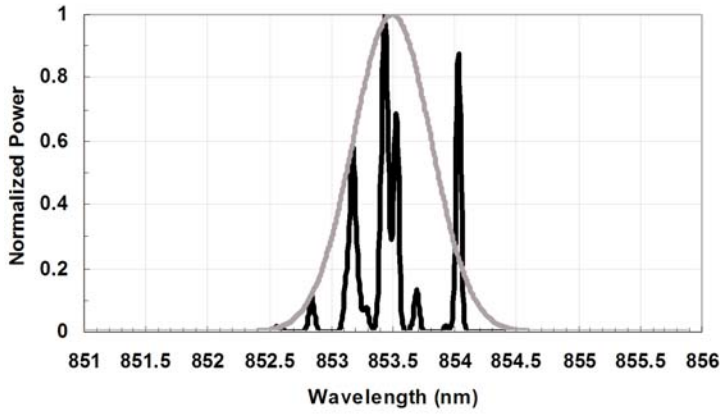

Threshold Current vs. Temperature: Threshold current varies parabolically with temperature; thus it can be nearly constant for a limited temperature range.

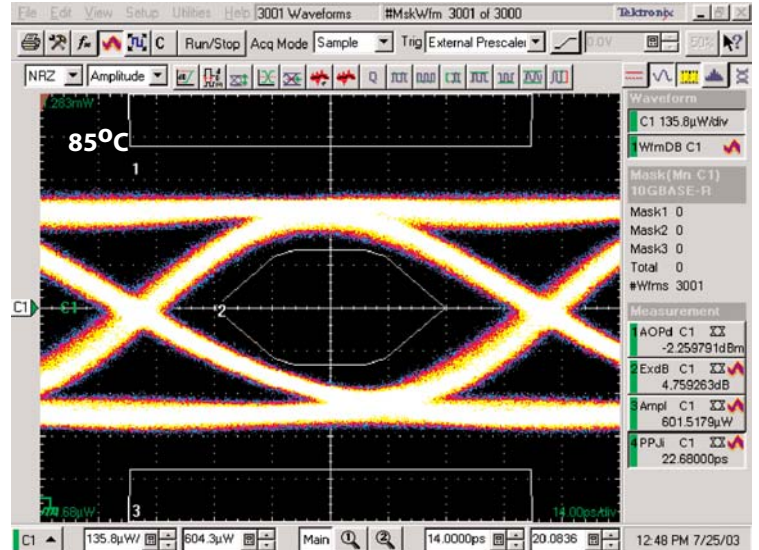
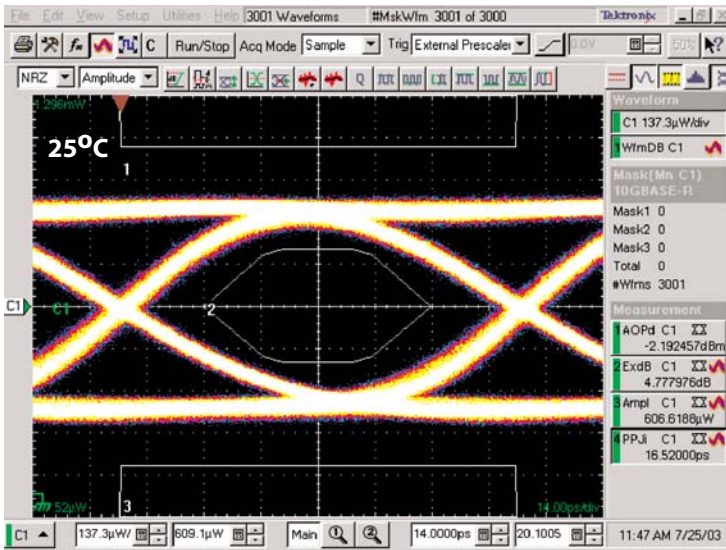
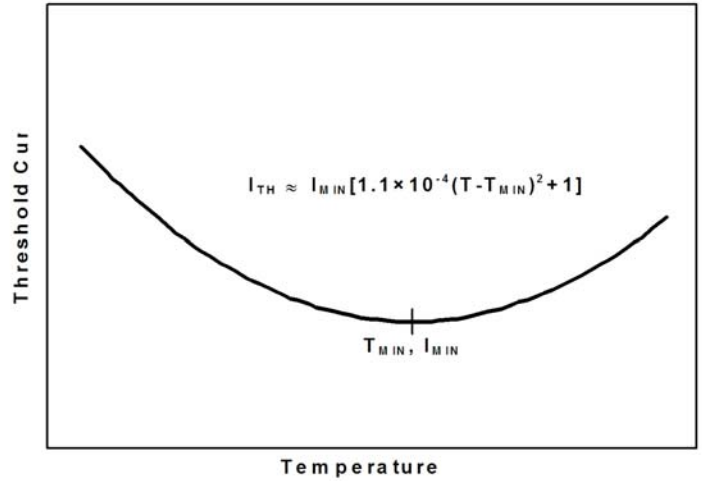

ADVANCED OPTICAL COMPONENTS

Finisar's ADVANCED OPTICAL COMPONENTS division was formed through strategic acquisition of key optical component suppliers. The company has led the industry in high volume Vertical Cavity Surface Emitting Laser (VCSEL) and associated detector technology since 1996. VCSELS have become the primary laser source for optical data communication, and are rapidly expanding into a wide variety of sensor applications. VCSELS' superior reliability, low drive current, high coupled power, narrow and circularly symmetric beam and versatile packaging options (including arrays) are enabling solutions not possible with other optical technologies. ADVANCED OPTICAL COMPONENTS is also a key supplier of Fabrey-Perot (FP) and Distributed Feedback (DFB) Lasers, and Optical Isolators (OI) for use in single mode fiber data and telecommunications networks

LOCATION

- Allen, TX - Business unit headquarters, VCSEL wafer growth, wafer fabrication and TO package assembly.
- Fremont, CA – Wafer growth and fabrication of 1310 to 1550nm FP and DFB lasers.
- Shanghai, PRC – Optical passives assembly, including optical isolators and splitters.

SALES AND SERVICE

Finisar's ADVANCED OPTICAL COMPONENTS division serves its customers through a worldwide network of sales offices and distributors. For application assistance, current specifications, pricing or name of the nearest Authorized Distributor, contact a nearby sales office or call the number listed below.

Finisar
Advanced Optical Components Division

Phone: 1-866-MY-VCSEL USA (toll free)
1-214-509-2700 USA (Direct dial)
44 (0) 174 336 5533 Europe
886-935-409898 China & Taiwan
81-90-4437-1130 Japan
82-11-220-6153 Asia Pacific & Korea

Fax: 1-2140509-3709 USA

Email: support@adopco.com
WEB: www.finisar.com/aoc.php

AOC CAPABILITIES

ADVANCED OPTICAL COMPONENTS' advanced capabilities include:

- 1, 2, 4, 8, and 10Gbps serial VCSEL solutions
- 1, 2, 4, 8, and 10Gbps serial SW DETECTOR solutions
- VCSEL and detector arrays
- 1, 2, 4, 8, and 10Gbps FP and DFB solutions at 1310 and 1550nm
- 1, 2, 4, 8, and 10Gbps serial LW DETECTOR solutions
- Optical Isolators from 1260 to 1600nm range
- Laser packaging in TO46, TO56, and Optical subassemblies with SC, LC, and MU interfaces for communication networks
- VCSELS operating at 670nm, 780nm, 980nm, and 1310nm in development
- Sensor packages include surface mount, various plastics, chip on board, chip scale packages, etc.
- Custom packaging options