

### ■ FEATURES

- Overvoltage Protection for 3.3V, 5V, and 12V Outputs.
- Power Good Signal for 5V Output.
- Remote ON/OFF Input.
- Uncommitted Protection Input.
- 5V Regulator with 25mA Source Current.
- 2.5V Precision Shunt Regulator.
- 8V to 16V Operation.
- Low Power Consumption.

### ■ APPLICATIONS

- PC Off-Line Power Management.

### ■ DESCRIPTION

The AIC1686 is a supervisory and protection IC intended for use in off-line, multiple output power supplies. It consists of protection circuitry, power good indicator, remote ON/OFF control, and precision shunt regulator. The overvoltage protection (OVP) function is for 3.3V, 5V, and 12V outputs. In addition, an uncommitted fault detection input (PRIN) is available for use with other protection functions, such as overcurrent, undervoltage, and/or short-circuit protection of outputs.

The shunt regulator has been included to implement the feedback control for one of the power supply's outputs. The noninverting input (EAI) is internally tied to a precision 2.5V reference.

The power good circuit monitors the 5V output and asserts, with a programmable delay, a TTL compatible high logic level at its output after the 5V output reaches the regulation range. The delay is programmed by a timing capacitor connected to CPG pin of the IC. The power good circuit sets its output low before the 5V output goes out of regulation range. The remote ON/OFF function enables the power supply to be turned on and off from the secondary side by a switch.

## ORDERING INFORMATION

AIC1686 XX  
 PACKAGE TYPE  
 N: PLASTIC DIP  
 TEMPERATURE RANGE  
 C: 0°C~70°C

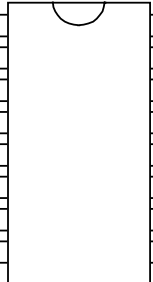
ORDER NUMBER	PIN CONFIGURATION
AIC1686CN (PLASTIC DIP)	TOP VIEW 

## TYPICAL APPLICATION CIRCUIT

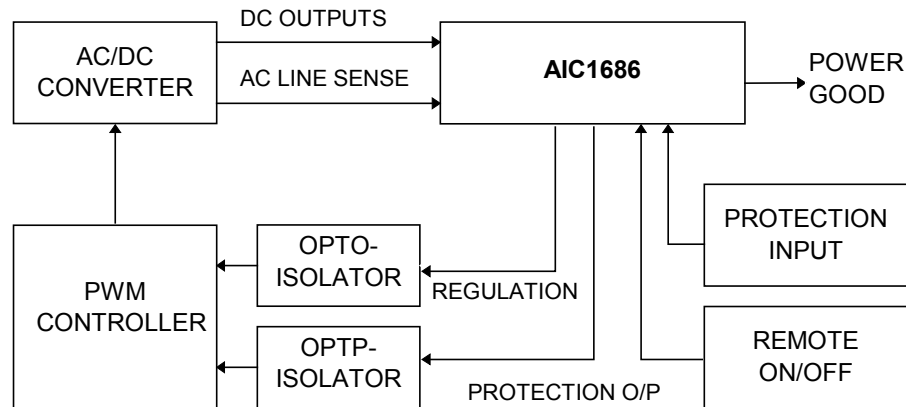

## ABSOLUTE MAXIMUM RATINGS

Supply Voltage, VCC .....-0.5V to 16V  
 Pins: V12, V5, V33, LS, EAO ..... -0.5V to 16V  
 Any Other Pins ..... GND - 0.5V to VCC+0.5V  
 Ambient Temperature Range ..... 0°C~70°C

### Thermal Information

Thermal Resistance,  $\theta_{JA}$  DIP Package ..... 110°C/W  
 Maximum Junction Temperature (Plastic Package) ..... 125°C  
 Maximum Storage Temperature Range ..... -65°C~150°C  
 Maximum Lead Temperature (Soldering 10 Sec) ..... 300°C  
 Maximum Power Dissipation ..... 500mW  
 (Derate at 10mW/°C above 70°C ambient)

## ■ TEST CIRCUIT

Refer to TYPICAL APPLICATION CIRCUIT.

## ■ ELECTRICAL CHARACTERISTICS (V<sub>CC</sub>= 12V, T<sub>a</sub>=25°C, unless otherwise specified.)

PARAMETER	TEST CONDITIONS	SYMBOL	MIN.	TYP.	MAX.	UNIT
<b>VCC Supply Current</b>						
Nominal Mode ( Remote On)	All Outputs Unloaded	I <sub>VCC</sub>		0.5	1	mA
Standby Mode ( Remote Off)	All Outputs Unloaded	I <sub>VCCSB</sub>		0.4	0.8	mA
<b>5V Reference (Note1)</b>						
Reference Voltage	I <sub>O</sub> =0 to 25mA, CL=1μF	V <sub>REF</sub>	4.85	5	5.15	V
Line Regulation	V <sub>CC</sub> =8V to 16V, CL=1μF				15	mV
<b>Error Amplifier</b>						
Internal Reference Voltage		V <sub>EA</sub>	2.45	2.5	2.55	V
Maximum Output Sink Current	V <sub>EAO</sub> =1V	I <sub>EA</sub>	20			mA
Open Loop Voltage Gain			80			dB
Unity Gain Bandwidth	CL=100pF	GBW		3		MHz
Power Supply Rejection Ratio		PSRR		85		dB
Slew Rate	CL=100pF	SR		2		V/μS
<b>Fault Detection</b>						
Fault Output High Voltage	I <sub>OH</sub> =500μA, Remote On	V <sub>FLOH</sub>	4			V
Fault Output High Voltage	I <sub>OH</sub> =20μA, Remote Off	V <sub>FLOHS</sub>	4			V
Fault Output Low Voltage	I <sub>OL</sub> =4.5mA	V <sub>FLOL</sub>			0.4	V
3.3V Input OVP Trip Level	Input Voltage Rising	V <sub>33_OVP</sub>	3.7	4	4.3	V
5V Input OVP Trip Level	Input Voltage Rising	V <sub>5_OVP</sub>	5.5	6	6.5	V
12V Input OVP Trip Level	Input Voltage Rising	V <sub>12_OVP</sub>	13.2	14	15.6	V
Protection Input Trip Level	Input Voltage Rising	V <sub>PIH</sub>	3.8			V
	Input Voltage Falling	V <sub>PIL</sub>			1.2	V
Fault Latch Delay		T <sub>FL</sub>	10	25	50	μS
<b>Remote ON/OFF</b>						
REMI Input Threshold	Input Voltage Rising	V <sub>RIH</sub>	3.8			V
	Input Voltage Falling	V <sub>RIL</sub>			1.2	V
REMI Input Hysteresis		HYS <sub>RI</sub>	0.7		1.8	V

**ELECTRICAL CHARACTERISTICS (CONTINUED)**

PARAMETER	TEST CONDITIONS	SYMBOL	MIN.	TYP.	MAX.	UNIT
REMI Pull High Resistor	REMI=L	$R_{RIL}$		100		K $\Omega$
	REMI=H	$R_{RIH}$		6		
REMO Output Low Voltage	$I_{OL}=4.5mA$	$V_{ROL}$			0.4	V
REMO Output High Voltage	$I_{OH}=500\mu A$	$V_{ROH}$	4			V
<b>Power Good</b>						
LS Input Clamp Voltage	$I_{LS}=1mA$	$V_{LSCMP}$	7.8	8.8	9.8	V
LS Input Rising Threshold	CLS=5V	$V_{LSH}$		6.2		V
LS Input Hysteresis Voltage		$HYS_{LS}$	1	1.2	1.6	V
CPG Timing Current	V5=5V	$I_{CPGH}$	6	9	12	$\mu A$
CPG Input Hysteresis		$HYS_{CPG}$		0.4		V
CPG Recharge Delay Time	LS (L to H)	$T_{RCPG}$		6.7		mS
PG Output High Voltage	$I_{OH}=5mA$	$V_{PGOH}$	4			V
PG Output Low Voltage	$I_{OL}=12mA$	$V_{PGOL}$			0.4	V
Delay LS Falling to PG Falling	CPG=1 $\mu F$	$T_{PGF}$		52		$\mu S$
Delay LS Rising to PG Rising	CPG=1 $\mu F$	$T_{PGR}$	150	300	450	mS
Delay REMI Rising to PG Falling		$T_{RIPGF}$		1		$\mu S$

Note1: A 1 $\mu F$  capacitor is connected between REF and GND to ensure a stable reference voltage.

**TYPICAL PERFORMANCE CHARACTERISTICS**

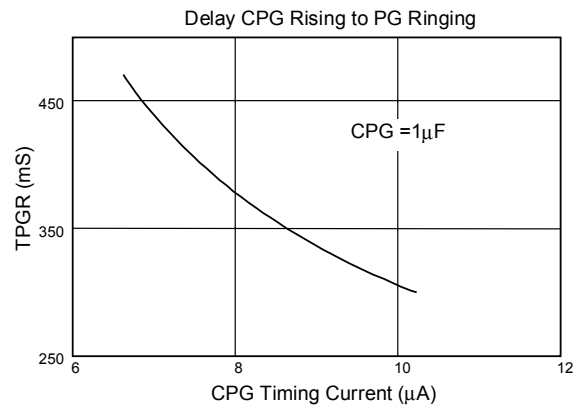
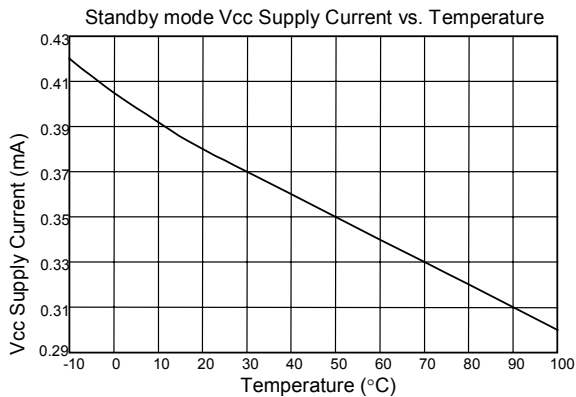
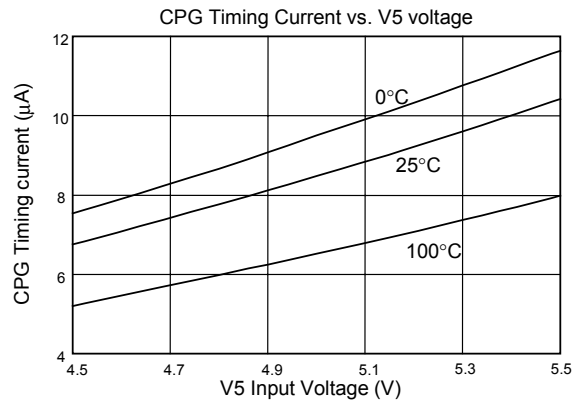
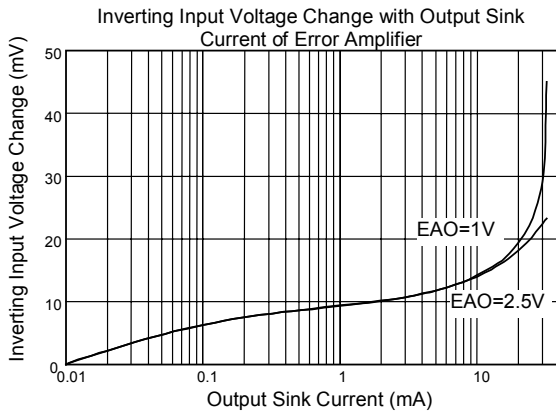
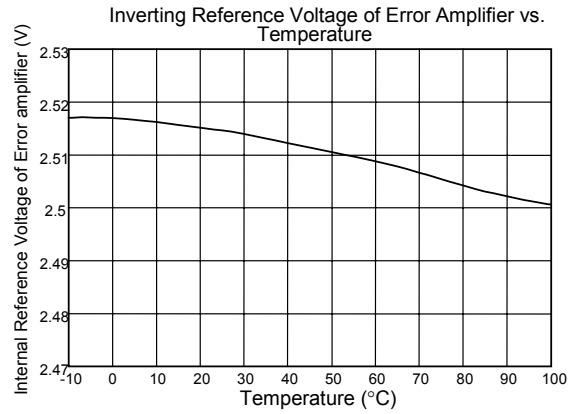
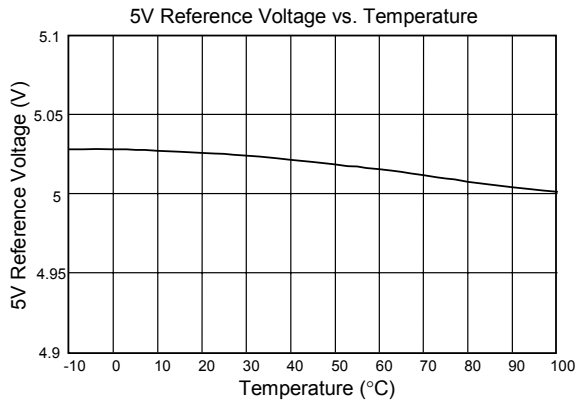

■ BLOCK DIAGRAM

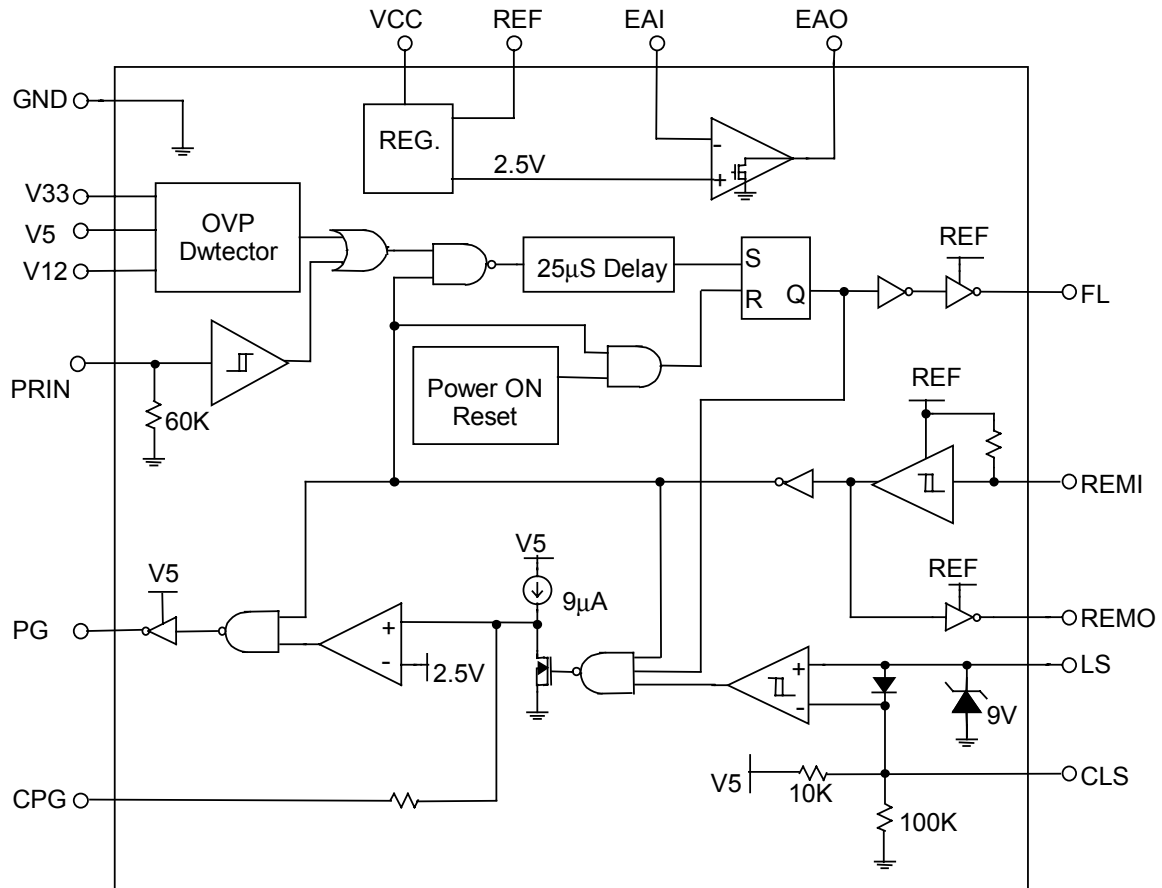

## ■ PIN DESCRIPTIONS

**IN 1: PRIN** - Auxiliary protection logic input to fault latch. HIGH for 25 $\mu$ S to set latch and cause FL output to go LOW. Internally active pulled down for normal operation.

**PIN 2: REMI** - Logic input for remote ON/OFF control power supply. LOW= REMOTE ON, HIGH=REMOTE OFF. In remote off state this chip goes into standby mode, FL=HIGH, REMO = LOW, and PG = LOW.

**PIN 3: PG** - Power good output signal. High level indicates that power is good.

**PIN 4: V33** - From 3.3V power supply. Used for overvoltage sensing only.

**PIN 5: GND** - Ground pin. Connect to ground on secondary side.

**PIN 6: V5** - From 5V power supply. Used for overvoltage sensing as well as internal supply for certain specific functions.

**PIN 7: V12** - From 12V power supply. Used for overvoltage sensing only.

**PIN 8: EAO** - Output of the error amplifier. Can be used to drive an opto-isolator.

**PIN 9: EAI** - Inverting input of the error amplifier, used to close voltage feedback loop.

**PIN 10: LS** - AC line sense input signal.

Use rectified output from main power transformer. Internally clamped to 9V and sinks up to 2mA.

**PIN 11: CLS** - Timing capacitor used to help ensure that a falling LS voltage is detected before power supply outputs fall out of regulation.

**PIN 12: VCC-** VCC supply input to IC. This should be a DC voltage between 8 and 16V.

**PIN 13: REF-** +5V precision reference output. May be used to supply up to 25mA to external circuitry.

**PIN 14: REMO-** Remote ON/OFF output that indicates the state of the power supply. HIGH = REMOTE ON, LOW=REMOTE OFF. This is essentially the inverse of the REMI input voltage.

**PIN 15: FL** - Fault output that indicates the fault condition. HIGH = NORMAL, LOW = FAULT. When fault states the PG goes LOW.

**PIN 16: CPG** -Timing capacitor that sets the delay from +5V main coming up to PG signal being asserted High.

$$T_{PGR} \approx \frac{2.5 \times C_{CPG}}{I_{CPGH}}$$

## ■ PACKAGE DIMENSION

- 16 LEAD PLASTIC DIP (unit: mm)

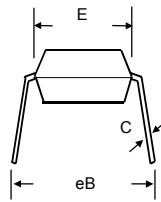
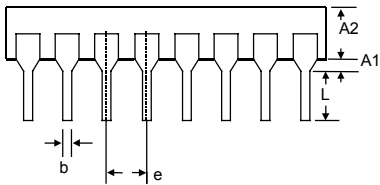
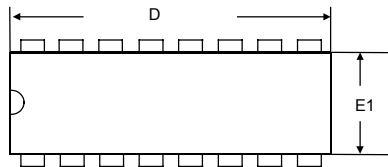

SYMBOL	MIN	MAX
A1	0.381	—
A2	2.92	4.96
b	0.35	0.56
C	0.20	0.36
D	18.66	19.69
E	7.62	8.26
E1	6.09	7.12
e	2.54(TYP)	
eB	—	10.92
L	2.92	3.81