

# MIP705

## Silicon MOS IC

### ■ Features

- 3-pin intelligent power device
- Five protective functions (over-current, over-voltage, short circuit load, over heat, ESD) are integrated
- Acceptable both AC and DC power supply

### ■ Applications

- For automotive electric equipment

### ■ Absolute Maximum Ratings (Ta = 25 ± 3°C)

Parameter	Symbol	Rated	Unit
Drain to Source voltage	V <sub>DS</sub>	60	V
Output peak current	I <sub>OP</sub>	±5	A
Output current	I <sub>O</sub>	-1 to 2 <sup>*1</sup>	A
Input voltage	V <sub>IN</sub>	-0.5 to 6	V
Input current	I <sub>IN</sub>	±10	mA
Drain clamp energy	EAS	55 <sup>*2</sup>	mJ
Allowable power dissipation	P <sub>D</sub>	1	W
		10 <sup>*3</sup>	
Operating ambient temperature	T <sub>opr</sub>	-40 to +85	°C
Channel temperature	T <sub>ch</sub>	150	°C
Storage temperature	T <sub>stg</sub>	-55 to +150	°C

\*1 Maximum load current, not the average current.

\*2 L = 10mH, I<sub>L</sub> = 3.32A, V<sub>DD</sub> = 30V, 1pulse, T<sub>C</sub> = 25°C

\*3 T<sub>C</sub> = 25°C

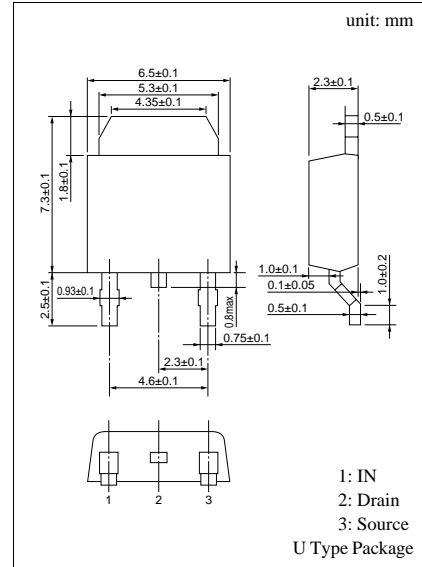

### ■ Block Diagram

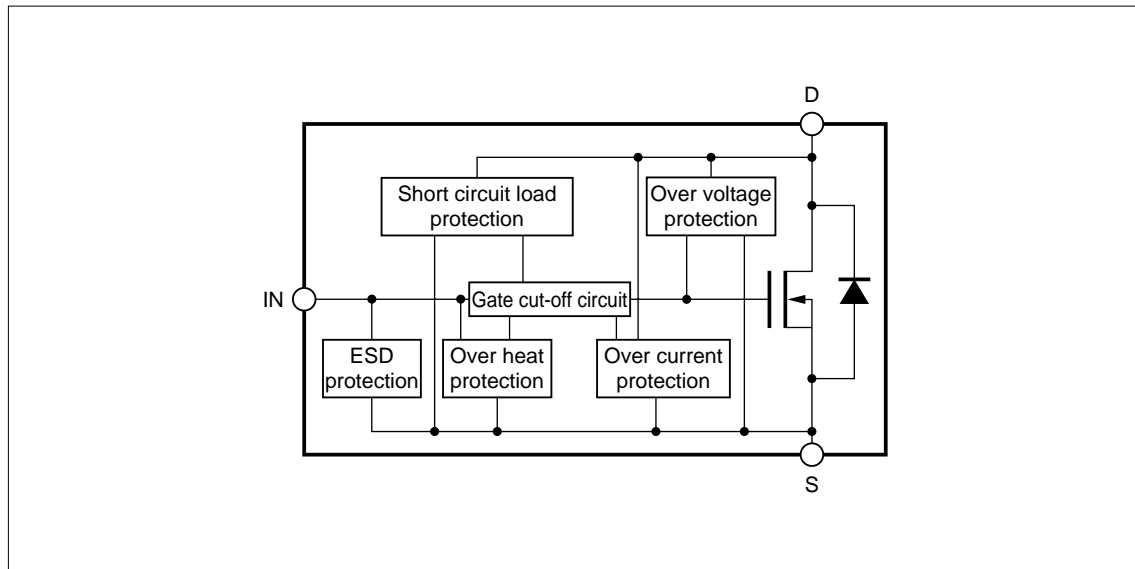

### ■ Electrical Characteristics ( $T_C = 25 \pm 2^\circ\text{C}$ )

Parameter	Symbol	Conditions	min	typ	max	Unit
Drain to Source ON-resistance	$R_{DS(on)}$	$V_{IN} = 5V, I_{DS} = 1.5A$		0.38	0.5	$\Omega$
Drain to Source ON-voltage	$V_{DS(on)}$	$V_{IN} = 5V, I_{DS} = 1.5A$		0.57	0.75	V
Drain clamp voltage	$V_{DS(CLIP)}$	$V_{IN} = 0, I_{DS} = 3mA$	60	72		V
Drain OFF current (1)	$I_{DS(off)1}$	$V_{IN} = 0, V_{DS} = 12V$		50	80	$\mu A$
Drain OFF current (2)	$I_{DS(off)2}$	$V_{IN} = 0, V_{DS} = 16V$		65	140	$\mu A$
Input voltage (High)	$V_{IN(H)}$	$I_{DS} = 2A$	4			V
Input voltage (Low)	$V_{IN(L)}$	$I_{DS} = 0.1mA$			0.8	V
Input current	$I_{IN(on)}$	$V_{IN} = 5V, V_{DS} = 0$		0.15	0.25	mA
Over current protection limit	$I_{OCP}$	$V_{IN} = 5V$	3.8	5	7.5	A
Short circuit load protection limit	$V_{DS(SHT)}$	$V_{IN} = 5V$	3			V

Note: The oscillation of the output current is caused when the drain voltage exceeds the short circuit load detection voltage under the ON state of output.

### ■ Operating condition

Parameter	Symbol	min	typ	max	Unit
Operating supply voltage	$V_{DD}$			40	V

### ■ Electrical Characteristics ( $T_C = 25 \pm 2^\circ\text{C}$ )

Parameter	Symbol	Conditions	min	typ	max	Unit
Over heat protection temperature	$T_{SHD}$	$V_{IN} = 5V$	170	205	240	$^\circ\text{C}$
Turn on delay time	$t_{d(on)}$	$V_{IN} = 5V, I_{DS} = 1.5A$ $V_{DD} = 12V, R_L = 8.2\Omega$		3		$\mu s$
Rise time	$t_r$		18		$\mu s$	
Turn off delay time	$t_{d(off)}$		12		$\mu s$	
Fall time	$t_f$		20		$\mu s$	

Note 1: The above values of characteristics are not guaranteed values and are only references for designing.

Note 2: If the chip temperature exceeds the "Over Heat Protection Temperature", output current is shut down.