



EMIF02-SPK01F2

IPAD™

2 LINE EMI FILTER AND ESD PROTECTION

MAIN PRODUCT CHARACTERISTICS:

Where EMI filtering in ESD sensitive equipment is required :

- Mobile phones and communication systems
- Computers, printers and MCU Boards

DESCRIPTION

The EMIF02-SPK01 is a highly integrated device designed to suppress EMI/RFI noise in all systems subjected to electromagnetic interferences. The EMIF02 Flip-Chip packaging means the package size is equal to the die size.

This filter includes an ESD protection circuitry which prevents damage to the application when subjected to ESD surges up to 15 kV.

BENEFITS

- EMI symmetrical (I/O) low-pass filter
- High efficiency in EMI filtering
- Very low PCB space consuming: 1.07 mm x 1.47 mm
- Very thin package: 0.65 mm
- High efficiency in ESD suppression
- High reliability offered by monolithic integration
- High reducing of parasitic elements through integration & wafer level packaging

COMPLIES WITH THE FOLLOWING STANDARDS:

IEC 61000-4-2

- Level 4 on input pins 15 kV (air discharge)
8 kV (contact discharge)
- Level 1 on output pins 2 kV (air discharge)
2 kV (contact discharge)

MIL STD 883E -Method 3015-6 Class 3

Figure 2: Basic Cell Configuration

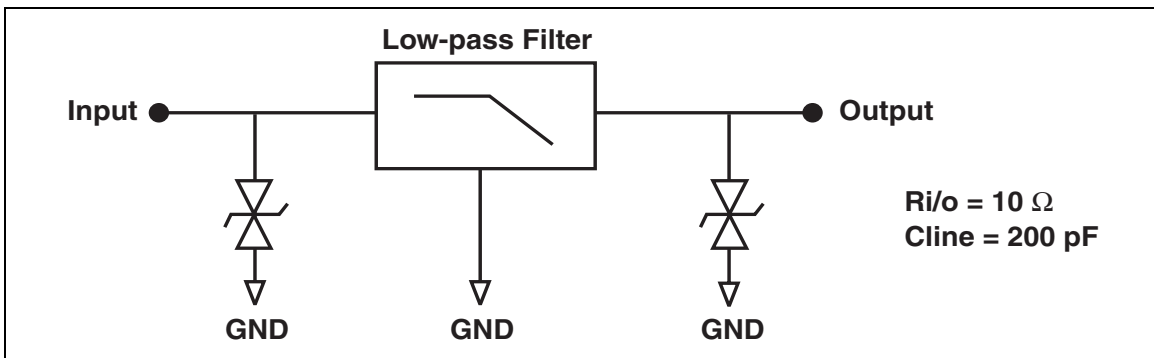

TM: IPAD is a trademark of STMicroelectronics.

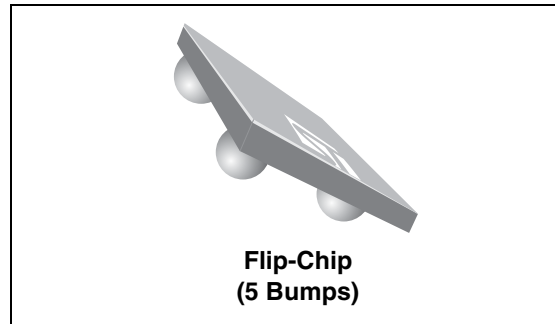
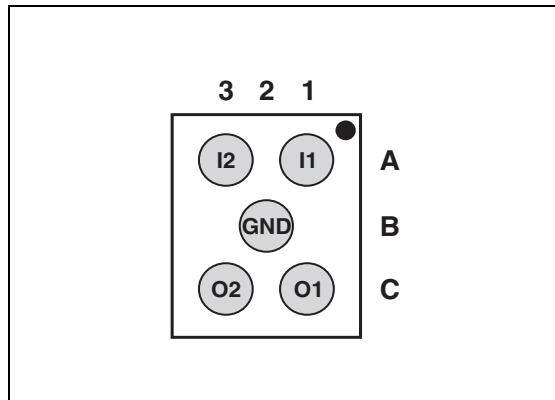

Table 1: Order Code

Part Number	Marking
EMIF02-SPK01F2	FX

Figure 1: Pin Configuration (bump side)



EMIF02-SPK01F2

Table 2: Absolute Ratings (limiting values)

Symbol	Parameter and test conditions	Value	Unit
T_j	Maximum junction temperature	125	°C
T_{op}	Operating temperature range	- 40 to + 85	°C
T_{stg}	Storage temperature range	- 55 to 50	°C

Table 3: Electrical Characteristics ($T_{amb} = 25\text{ °C}$)

Symbol	Parameter
V_{BR}	Breakdown voltage
I_{RM}	Leakage current @ V_{RM}
V_{RM}	Stand-off voltage
V_{CL}	Clamping voltage
R_d	Dynamic impedance
I_{PP}	Peak pulse current
$R_{I/O}$	Series resistance between Input & Output
C_{line}	Input capacitance per line

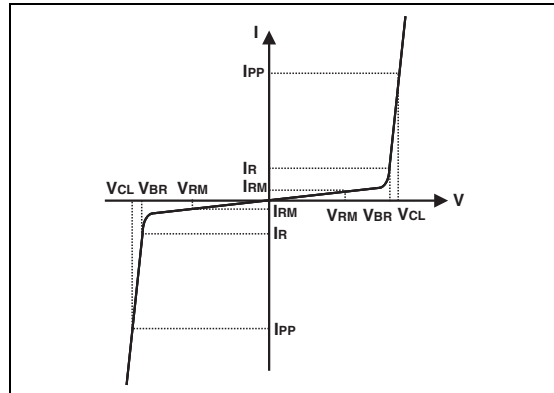

Symbol	Test conditions	Min.	Typ.	Max.	Unit
V_{BR}	$I_R = 1\text{ mA}$	6	8		V
I_{RM}	$V_{RM} = 3\text{ V per line}$			500	nA
$R_{I/O}$	Tolerance $\pm 20\%$		10		Ω
C_{line}	$V_R = 0\text{ V}$		200		pF

Figure 3: S21 (dB) attenuation measurements and ApIac simulation

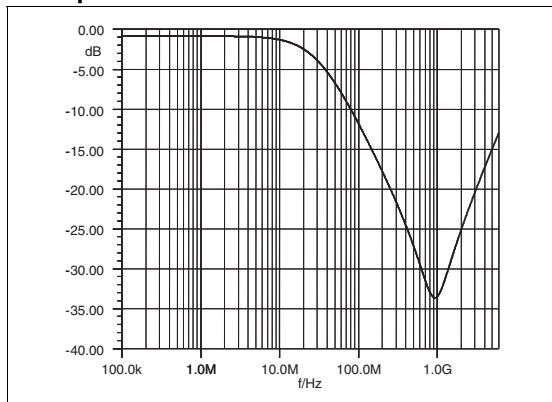

Figure 4: Analog crosstalk measurements

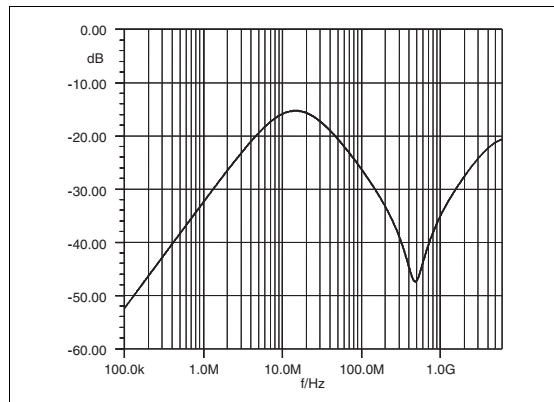

Figure 5: ESD response to IEC61000-4-2 (+ 15kV air discharge) on one input V(in) and one output V(out)

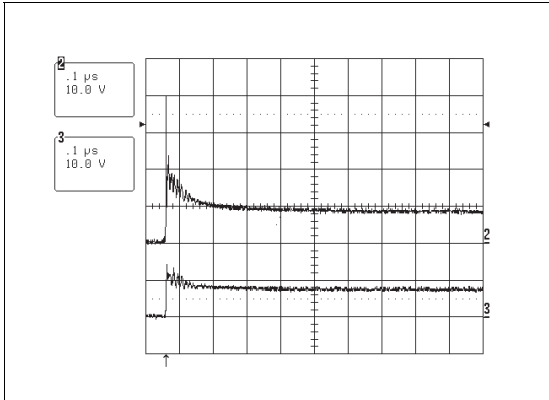

Figure 6: ESD response to IEC61000-4-2 (15kV air discharge) on one input V(in) and one output V(out)

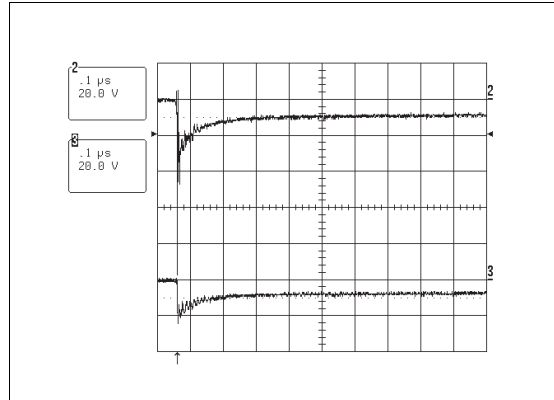

Figure 7: Line capacitance versus applied voltage

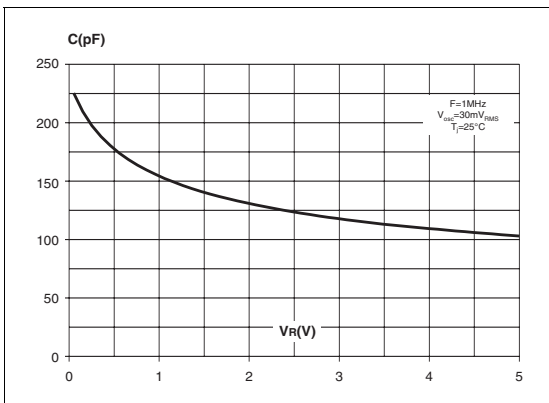

Figure 8: Aplac model

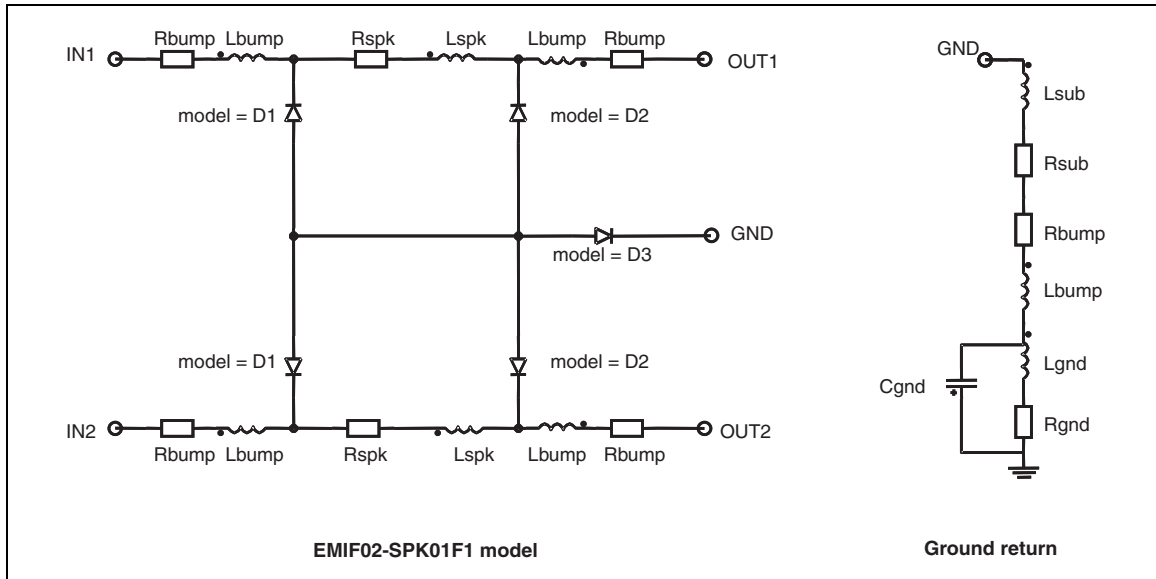

Figure 9: Aplac parameters

Model D1	Model D3	Model D2	aplacvar Ls 1nH
CJO=Cdiode1	CJO=Cdiode3	CJO=Cdiode2	aplacvar Rs 150m
BV=7	BV=7	BV=7	aplacvar Rspk 10
IBV=1u	IBV=1u	IBV=1u	aplacvar Lspk 10p
IKF=1000	IKF=1000	IKF=1000	aplacvar Cdiode1 234pF
IS=10f	IS=10f	IS=10f	aplacvar Cdiode2 3.5ppF
ISR=100p	ISR=100p	ISR=100p	aplacvar Cdiode3 1nF
N=1	N=1	N=1	aplacvar Lbump 50pH
M=0.3333	M=0.3333	M=0.3333	aplacvar Rbump 10m
RS=0.7	RS=0.12	RS=0.3	aplacvar Rsub 0.5m
VJ=0.6	VJ=0.6	VJ=0.6	aplacvar Lsub 10pH
TT=50n	TT=50n	TT=50n	aplacvar Rgnd 1m
			aplacvar Lgnd 50pH
			aplacvar Cgnd 0.15pF

Figure 10: Order code

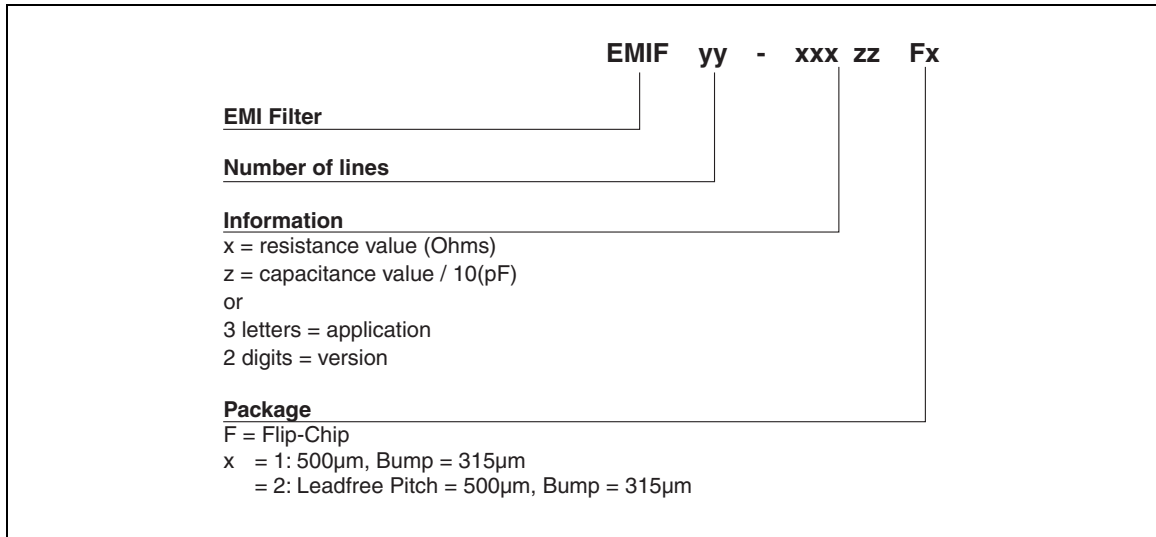

Figure 11: FLIP-CHIP Package Mechanical Data

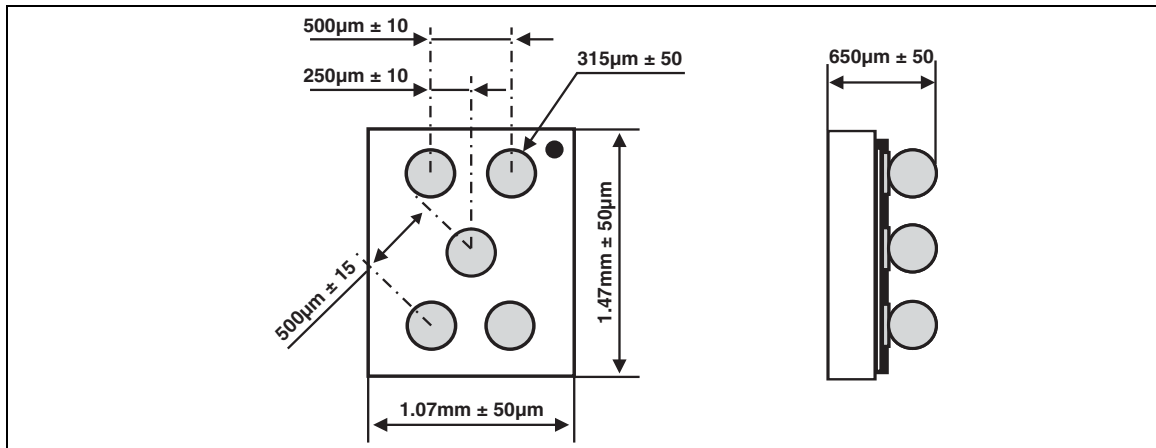

Figure 12: Foot print recommendations

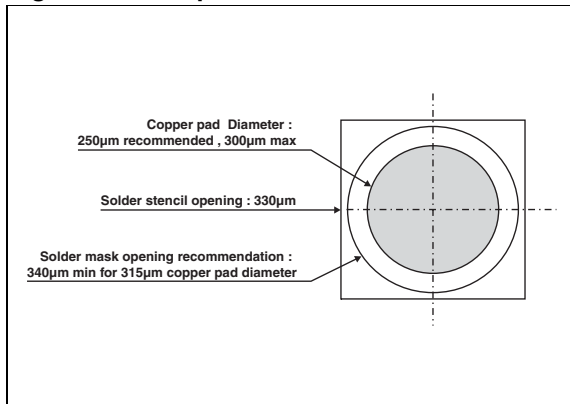

Figure 13: Marking

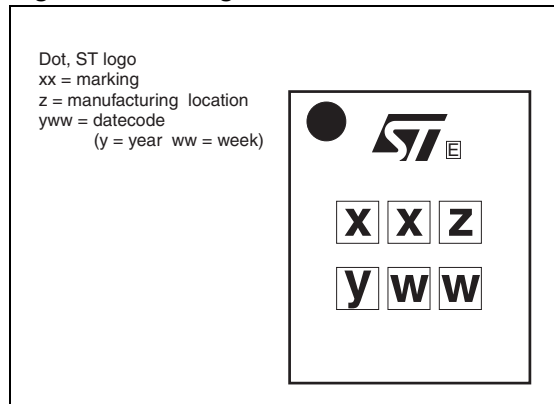
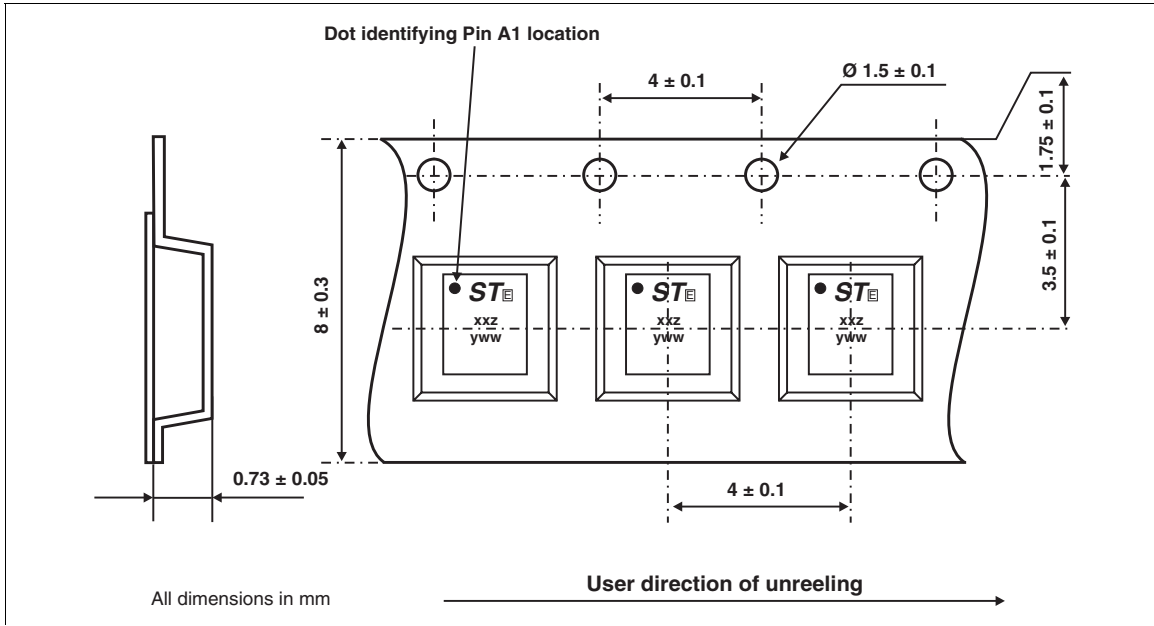

Figure 14: FLIP-CHIP Tape and Reel Specification



In order to meet environmental requirements, ST offers these devices in ECOPACK® packages. These packages have a Lead-free second level interconnect . The category of second level interconnect is marked on the package and on the inner box label, in compliance with JEDEC Standard JESD97. The maximum ratings related to soldering conditions are also marked on the inner box label. ECOPACK is an ST trademark. ECOPACK specifications are available at: www.st.com.

Table 4: Ordering Information

Ordering code	Marking	Package	Weight	Base qty	Delivery mode
EMIF02-SPK01F2	FX	Flip-Chip	2.1 mg	5000	Tape & reel (7")

Note: More packing informations are available in the application notes
 AN1235: "Flip-Chip: Package description and recommendations for use"
 AN1751: "EMI Filters: Recommendations and measurements"

Table 5: Revision History

Date	Revision	Description of Changes
14-Oct-2004	1	First issue

Information furnished is believed to be accurate and reliable. However, STMicroelectronics assumes no responsibility for the consequences of use of such information nor for any infringement of patents or other rights of third parties which may result from its use. No license is granted by implication or otherwise under any patent or patent rights of STMicroelectronics. Specifications mentioned in this publication are subject to change without notice. This publication supersedes and replaces all information previously supplied. STMicroelectronics products are not authorized for use as critical components in life support devices or systems without express written approval of STMicroelectronics.

The ST logo is a registered trademark of STMicroelectronics.
All other names are the property of their respective owners

© 2005 STMicroelectronics - All rights reserved

STMicroelectronics group of companies

Australia - Belgium - Brazil - Canada - China - Czech Republic - Finland - France - Germany - Hong Kong - India - Israel - Italy - Japan -
Malaysia - Malta - Morocco - Singapore - Spain - Sweden - Switzerland - United Kingdom - United States of America
www.st.com

