

DN6848/SE/TE/S

Hall IC (Operating Temperature Range
 $T_{opr} = -40$ to $+100^{\circ}\text{C}$, Operating in One
 Way Magnetic Field)

Overview

The DN6848/SE/TE/S is a combination of a Hall element, amplifier, Schmitt circuit, and stabilized power supply/temperature compensator integrated on an identical chip by using the IC technology. It amplifies Hall element output at the amplifier, converts into a digital signal through the Schmitt circuit, and drives the TTL or MOS IC directly.

Features

- High sensitivity and low drift
- Stable temperature characteristics due to the additional temperature compensator
- Wide operating supply voltage range ($V_{CC}=4.5$ to 16V)
- Operating in one way magnetic field
- TTL and MOS ICs directly drivable by output
- Output open collector

Applications

- Speed sensors
- Position sensors
- Rotation sensors
- Keyboard switches
- Microswitches

Note) This IC is not suitable for car electrical equipments.

Block Diagram

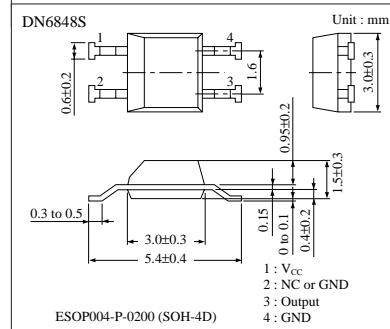
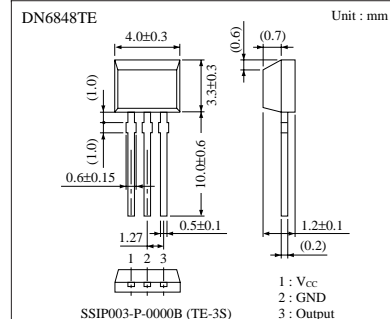
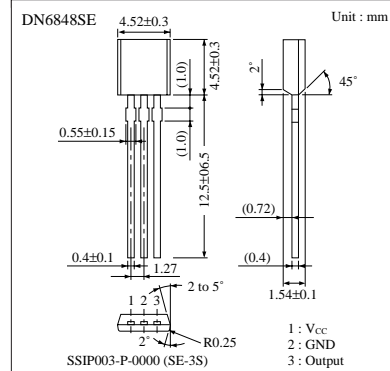
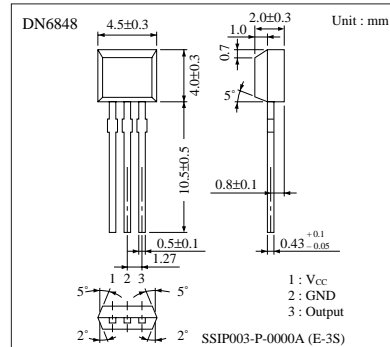
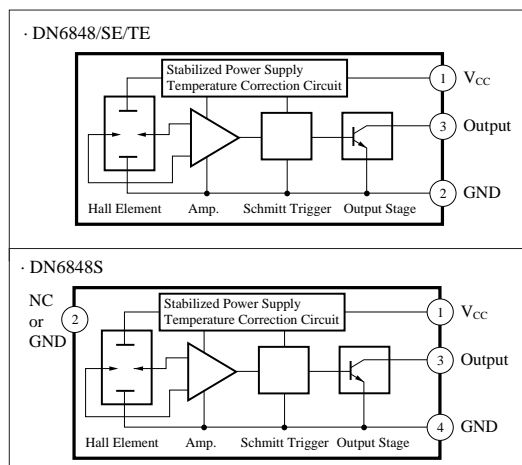

■ Absolute Maximum Ratings (Ta=25°C)

Parameter	Symbol	Rating	Unit
Supply voltage	V _{CC}	18	V
Supply current	I _{CC}	8	mA
Circuit current	I _O	20	mA
Power dissipation	P _D	150	mW
Operating ambient temperature	T _{opr}	-40 to +100	°C
Storage temperature	T _{stg}	-55 to +125	°C

■ Electrical Characteristics (Ta=25°C)

Parameter	Symbol	Condition	min	typ	max	Unit
Operating flux density	B ₁ (L to H)	V _{CC} =12V	0.5	9	21	mT
	B ₂ (H to L)	V _{CC} =12V	1.5	11	22	mT
Hysteresis width	BW	V _{CC} =12V	1	2	—	mT
Low output voltage	V _{OL}	V _{CC} =16V, I _O =12mA, B=22mT	—	—	0.4	V
		V _{CC} =4.5V, I _O =12mA, B=22mT	—	—	0.4	V
High output current	I _{OH}	V _{CC} =4.5 to 16V V _O =16V, B=0mT	—	—	10	μA
Supply current	I _{CC}	V _{CC} =16V	—	—	6	mA
		V _{CC} =4.5V	—	—	5.5	mA

■ Hall Element Position

Unit : mm
The center of the Hall element is in the hatched area in the right figure.

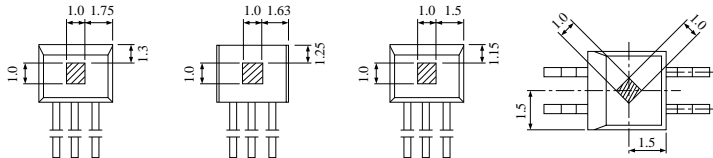

Distance from package surface to sensor (mm)	DN6848	DN6848SE	DN6848TE	DN6848S
		0.7	0.42	0.4

■ Flux-Voltage Conversion Characteristics

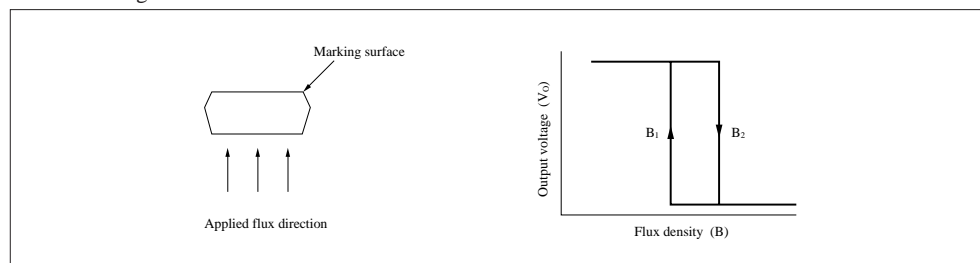

■ Precaution on Use

1. Change of the operation magnetic flux density does not depend on the supply voltage, because the stabilization power supply is built-in. (only for the range ; $V_{CC}=4.5$ to 16V)
2. Change from "H" to "L" level increases the supply current by approx. 1mA.

■ Characteristics Curve

Supply voltage – Ambient temperature

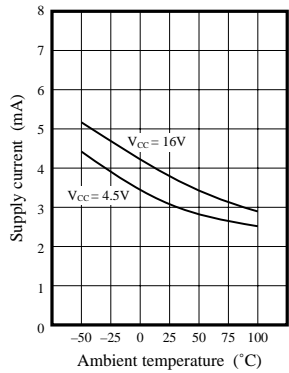

Operating flux density – Ambient temperature

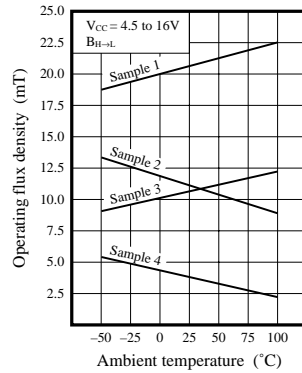

Operating flux density – Supply voltage

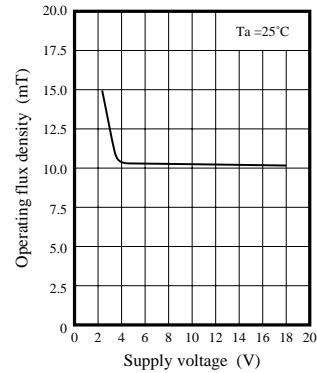

Output low level voltage – Ambient temperature

