

# KA3100D

## Stepping Motor Driver

### Features

- Built-in vertical PNP power transistors
- Wide supply voltage range( $V_{CC} = 2.5V \sim 7.0V$ )
- Low saturation voltage ( $0.4V @ 0.4A$ )
- Built-in chip enable function
- Built-in shoot-through current protector
- Built-in thermal shutdown(TSD) function
- Built-in current-mode control circuit (IPEAK: 1A)

### Description

The KA3100D is a monolithic integrated circuit designed for a two-phase stepping motor driver of a FDD system.

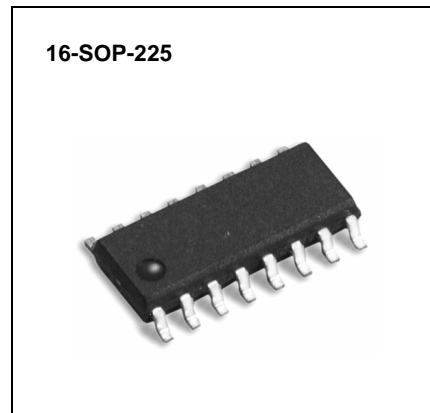

### Typical Application

- Floppy disk drive
- Camera stepping motor
- General stepping motor

### Ordering Information

Device	Package	Operating Temp.
KA3100D	16-SOP-225	-20 ~ +75°C
KA3100DTF	16-SOP-225	-20 ~ +75°C

## Pin Assignments

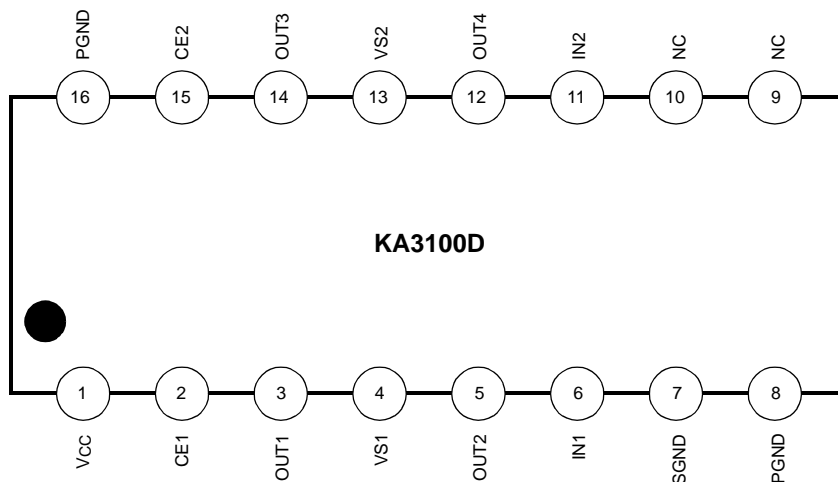

## Pin Definitions

Pin Number	Pin Name	I/O	Pin Function Description
1	VCC	-	Logic part supply voltage
2	CE1	I	Chip enable 1
3	OUT1	O	Output 1
4	VS1	-	Power supply 1
5	OUT2	O	Output 2
6	IN1	I	Input 1
7	SGND	-	Signal ground
8	PGND	-	Power ground
9	NC	-	No connection
10	NC	-	No connection
11	IN2	I	Input 2
12	OUT4	O	Output 4
13	VS2	-	Power supply 2
14	OUT3	O	Output 3
15	CE2	I	Chip enable 2
16	PGND	-	Power ground

## Internal Block Diagram

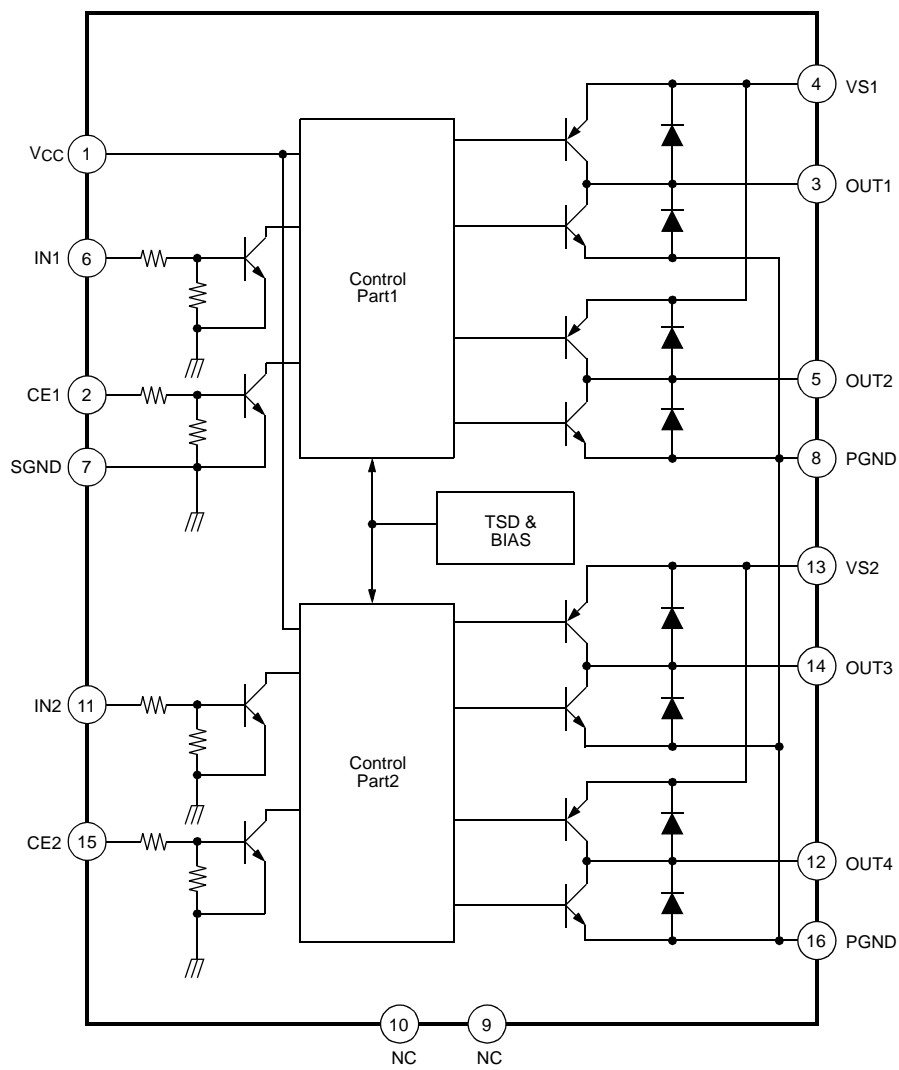

## Absolute Maximum Ratings (Ta = 25°C)

Parameter	Symbol	Value	Unit
Supply voltage	VCC(MAX)	9.0	V
Power supply voltage	VS(MAX)	9.0	V
Output voltage	VOUT(MAX)	VS + Vef	V
Input voltage	VIN(MAX)	7.0	V
Peak output current	IO(PEAK)	1	A
Continuous output current	IO	0.4	A
Power dissipation	PD	0.55	W
Junction temperature	TJ	150	°C
Storage temperature	TSTG	-40 ~ 125	°C
Operating temperature	TA	-20 ~ 75	°C

## Power Dissipation Curve

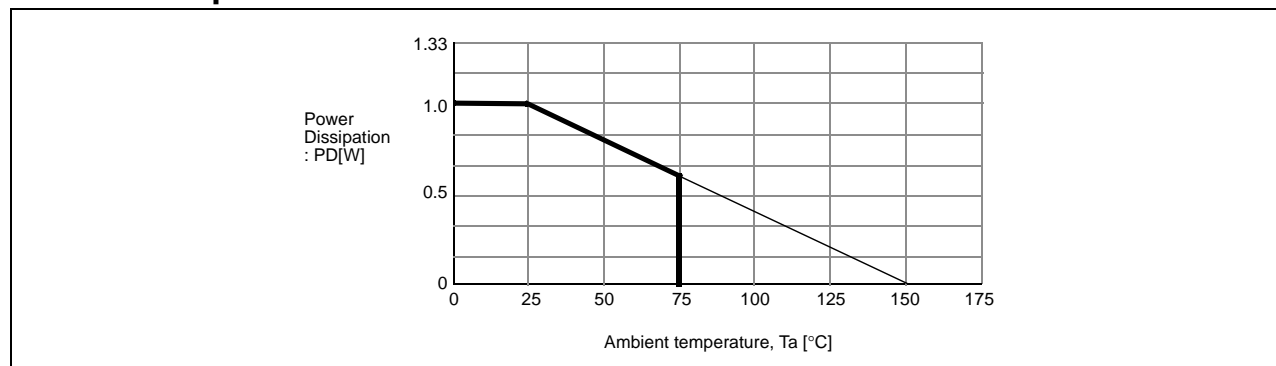

Power dissipation decreases at the rate of 13.6mW / °C when mounted on 30mm × 30mm × 1.5mm PCB (Phenolic resin material) and used above Ta=25°C.

## Recommended Operating Conditions (Ta = 25°C)

Parameter	Symbol	Min.	Typ.	Max	Unit
Logic circuit supply voltage	VCC	2.5	-	7.0	V
Power supply voltage	VS	2.5	-	7.0	V

## Electrical Characteristics

( $T_a=25^\circ\text{C}$ ,  $V_{CC}=5\text{V}$ ,  $V_{S1}=3\text{V}$ ,  $V_{S2}=3\text{V}$ , unless specified otherwise)

Parameter	Symbol	Conditions	Min.	Typ.	Max.	Units
Supply current 1	$I_{CC1}$	$CE1, 2=0\text{V}$ , $V_{INL}=3\text{V}$ or $0\text{V}$ , Each CH.	-	0.1	10	$\mu\text{A}$
Supply current 2	$I_{CC2}$	$CE1=3\text{V}$ , $V_{INL}=3\text{V}$ or $0\text{V}$ , Each CH.	-	12	18	$\text{mA}$
Saturation voltage 1	$V_{SAT1}$	$CE1=3\text{V}$ , $V_{INL}=3\text{V}$ or $0\text{V}$ , $I_{OUT}=0.2\text{A}$	-	0.2	0.3	$\text{V}$
Saturation voltage 2	$V_{SAT2}$	$CE1=3\text{V}$ , $V_{INL}=3\text{V}$ or $0\text{V}$ , $I_{OUT}=0.4\text{A}$	-	0.4	0.6	$\text{V}$
Input high level voltage	$V_{INH}$	-	1.8	-	$V_{CC}$	$\text{V}$
Input low level voltage	$V_{INL}$	-	-0.3	-	0.7	$\text{V}$
Input current	$I_{IN}$	$V_{IN}=3\text{V}$ , Each CH	-	100	200	$\mu\text{A}$
Chip enable current	$I_{CE}$	$CE=0\text{V}$ , Each CH	-	100	200	$\mu\text{A}$
Clamp diode leakage current	$I_{LEAK}$	$V_{CC}=7\text{V}$ , $V_S=7\text{V}$	-	-	30	$\mu\text{A}$
Clamp diode voltage	$V_{EF}$	$I_{OUT}=0.4\text{A}$	-	-	1.7	$\text{V}$

## Function Descriptions

IN1 & IN2	CE1 & CE2	OUT1 & OUT3	OUT2 & OUT4	Motor rotation
Low	High	High	Low	Forward
High	High	Low	High	Reverse
Low	Low	Off	Off	Stand-by
High	Low	Off	Off	Stand-by

## Typical Performance Characteristics

### $v_{out(sat)}$ vs $i_o$ Characteristic Graph

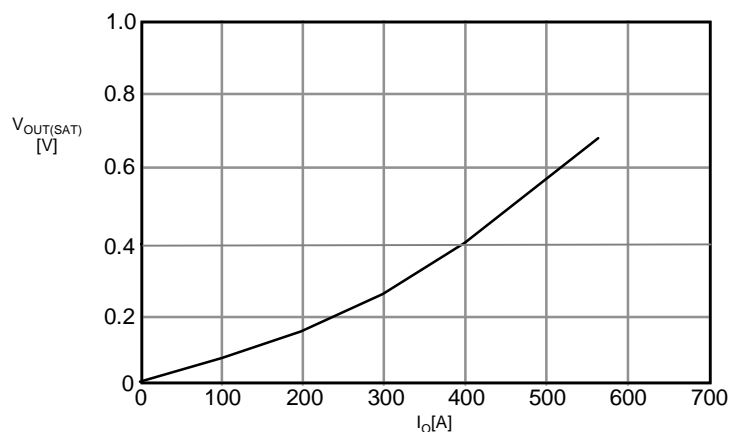

## Test Circuits

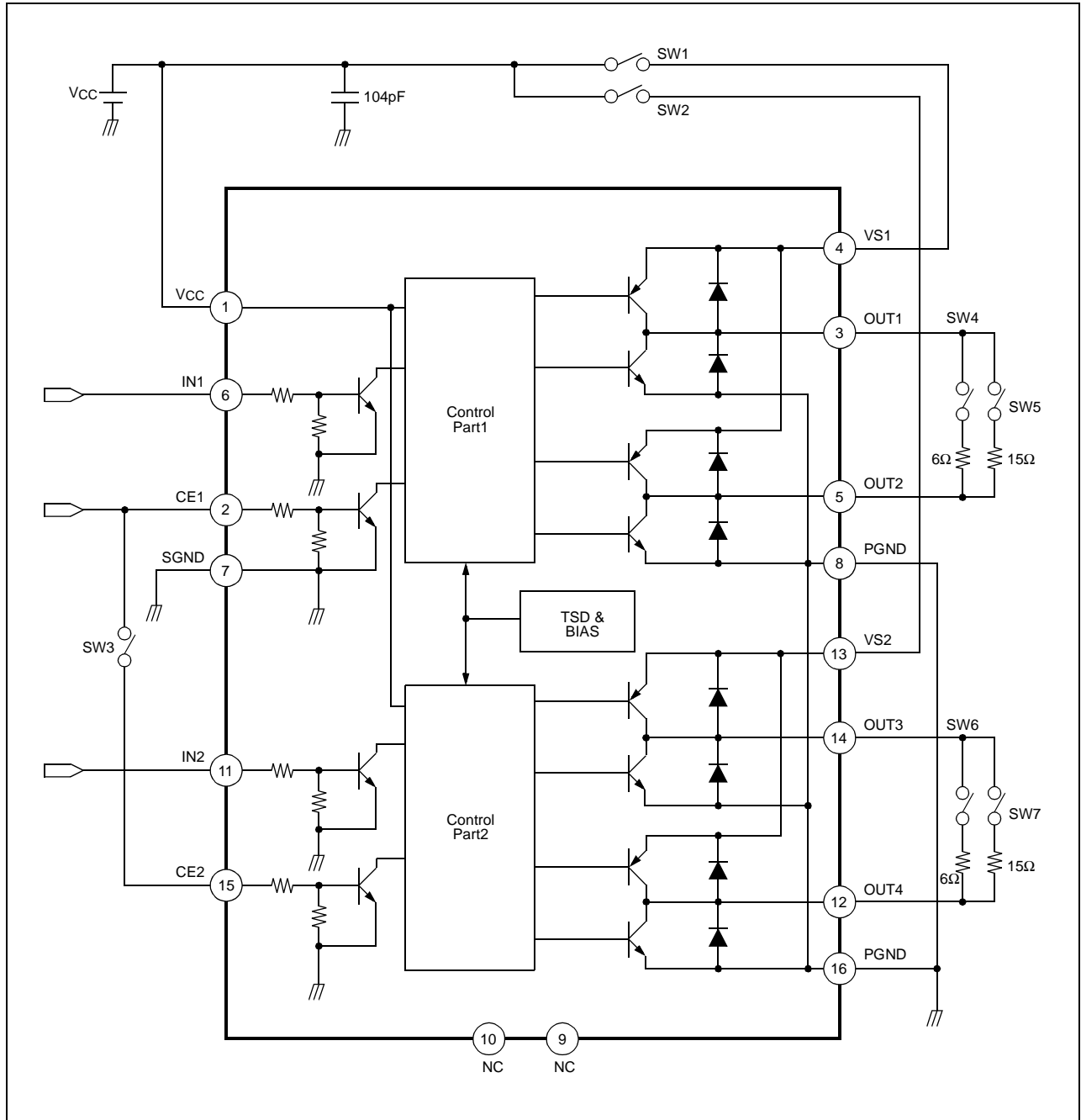

## Typical Application Circuits

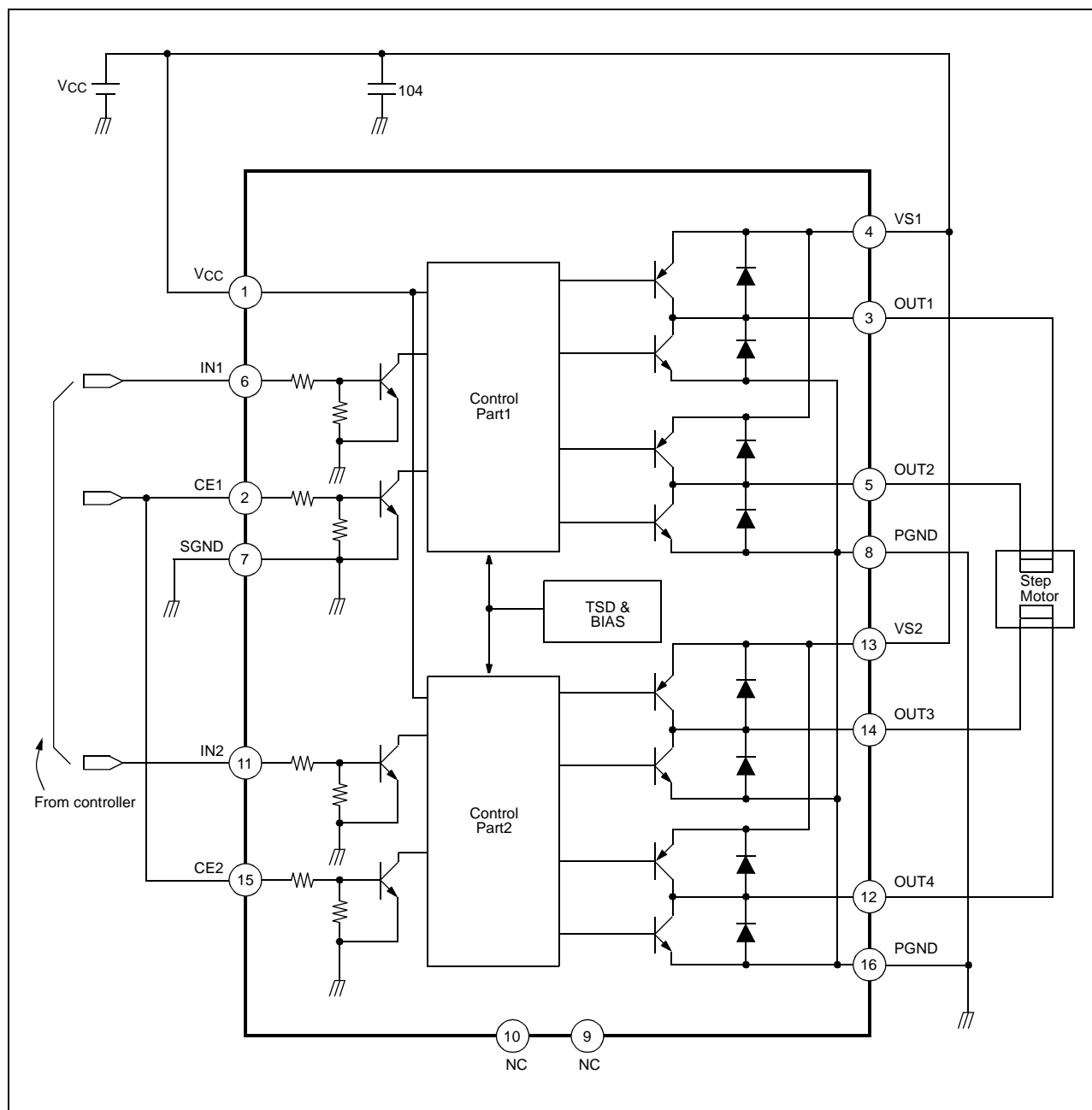

**DISCLAIMER**

FAIRCHILD SEMICONDUCTOR RESERVES THE RIGHT TO MAKE CHANGES WITHOUT FURTHER NOTICE TO ANY PRODUCTS HEREIN TO IMPROVE RELIABILITY, FUNCTION OR DESIGN. FAIRCHILD DOES NOT ASSUME ANY LIABILITY ARISING OUT OF THE APPLICATION OR USE OF ANY PRODUCT OR CIRCUIT DESCRIBED HEREIN; NEITHER DOES IT CONVEY ANY LICENSE UNDER ITS PATENT RIGHTS, NOR THE RIGHTS OF OTHERS.

**LIFE SUPPORT POLICY**

FAIRCHILD'S PRODUCTS ARE NOT AUTHORIZED FOR USE AS CRITICAL COMPONENTS IN LIFE SUPPORT DEVICES OR SYSTEMS WITHOUT THE EXPRESS WRITTEN APPROVAL OF THE PRESIDENT OF FAIRCHILD SEMICONDUCTOR INTERNATIONAL. As used herein:

1. Life support devices or systems are devices or systems which, (a) are intended for surgical implant into the body, or (b) support or sustain life, and (c) whose failure to perform when properly used in accordance with instructions for use provided in the labeling, can be reasonably expected to result in a significant injury of the user.
2. A critical component in any component of a life support device or system whose failure to perform can be reasonably expected to cause the failure of the life support device or system, or to affect its safety or effectiveness.