

PLEASE CHECK WWW.MOLEX.COM FOR LATEST PART INFORMATION

Part Number: [0351500610](#)
Status: **Active**
Overview: [versablade](#)
Description: 7.30mm (.287") Pitch Wire-to-Wire VersaBlade™ Hybrid Plug Housing, with Mounting Ears, 6 Circuits, Polyester UL94V-0, Natural

Documents:

[3D Model](#) [RoHS Certificate of Compliance \(PDF\)](#)
[Drawing \(PDF\)](#)

Agency Certification

CSA	LR19980
TUV	R72090206
UL	E29179

General

Product Family	Crimp Housings
Series	35150
Comments	Polarized to Mating Part, Positive Lock
Overview	versablade
Product Name	VersaBlade™

Physical

Circuits (maximum)	6
Color - Resin	Natural
Flammability	94V-0
Gender	Female
Glow-Wire Compliant	No
Keying to Mating Part	None
Lock to Mating Part	Yes
Material - Resin	Polyester
Number of Rows	2
Packaging Type	Bag
Panel Mount	Yes
Pitch - Mating Interface (in)	0.287 In
Pitch - Mating Interface (mm)	7.30 mm
Polarized to Mating Part	Yes
Stackable	No
Temperature Range - Operating	-40°C to +120°C

Material Info

Reference - Drawing Numbers

Sales Drawing [SD-35150-061*](#)

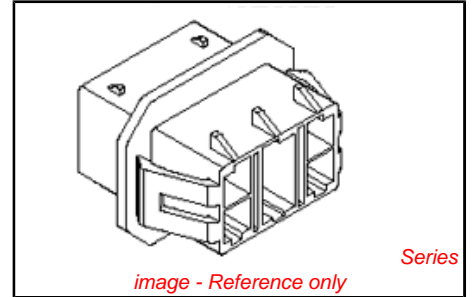

EU RoHS
ELV and RoHS
Compliant
REACH SVHC
 Not Reviewed
Halogen-Free
Status
Not Reviewed

China RoHS



Need more information on product environmental compliance?

Email productcompliance@molex.com
 For a multiple part number RoHS Certificate of Compliance, [click here](#)

Please visit the [Contact Us](#) section for any non-product compliance questions.

Search Parts in this Series
[35150Series](#)

Mates With
[35151-0610](#) Receptacle Housing,
[35151-0614](#) Receptacle Housing

Use With
 VersaBlade™ Crimp Terminals, [35745](#) ,
[35746](#) , [35747](#)

PLEASE CHECK WWW.MOLEX.COM FOR LATEST PART INFORMATION

10 9 8 7 6 5 4 3 2 1

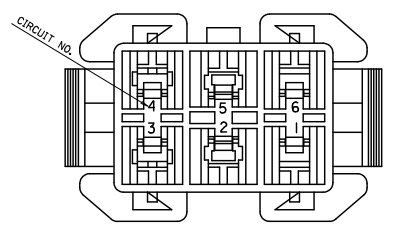

VIEW 'A'

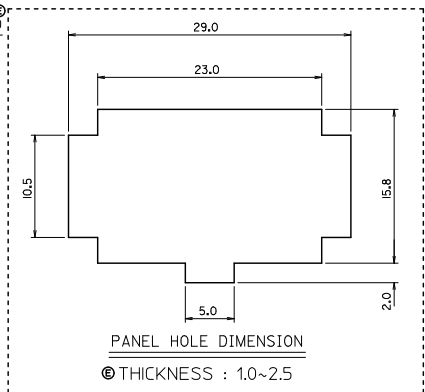
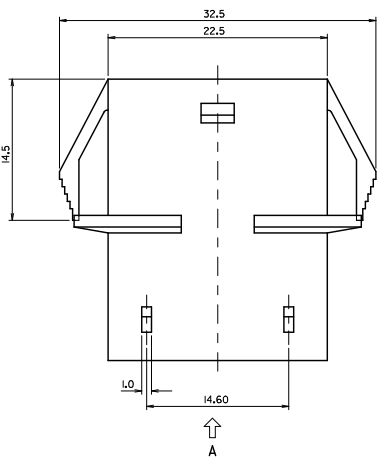
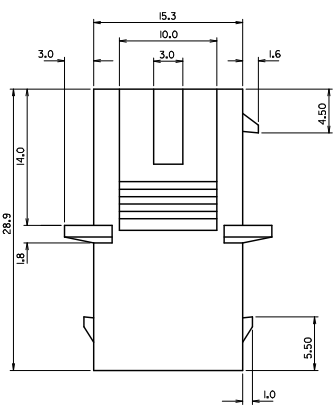
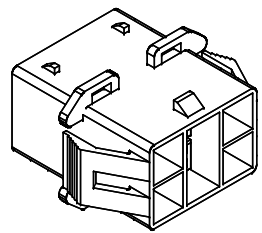
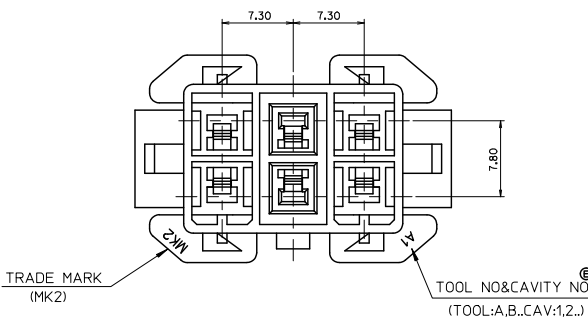

- NOTES.
1. MATERIAL & COLOR : SEE TABLE
 2. MATED HOUSING : 35151-061*/#619
 3. APPLICABLE TERMINAL : 35745-***** (3,4 CKT)
35746-***** (2,5 CKT)
35747-***** (1,6 CKT)
 4. APPLICABLE T.P.A : 35150-039*
 5. PRODUCT SPECIFICATION : PS-35150-003

NO	PRODUCT	MATERIAL	
	PART NO	COLOR	DESCRIPTION
1	35150-0610	NATURAL	POLYESTER (PBT) (UL94V-0)
2	35150-0612	RED	
3	35150-0614	BLUE	
4	35150-0619	NATURAL	PC/PET (UL94V-0)
5	35150-2619	RED	
6	35150-3619	YELLOW	
7	35150-4619	BLUE	

REVISED
 IEC NO: KOR2010-0092
 DRAWN: HPARK01 2010/01/14
 CHECKED: YANG 2010/01/14
 APPROVED: KIM 2010/01/14

QUALITY SYMBOLS	GENERAL TOLERANCES (UNLESS SPECIFIED)	
	mm	INCH
$\nabla=0$	4 PLACES ± ---	± ---
$\nabla=0$	3 PLACES ± ---	± ---
	2 PLACES ± 0.3	± ---
	1 PLACE ± 0.3	± ---
	ANGULAR ± 3°	
	DRAFT WHERE APPLICABLE MUST REMAIN WITHIN DIMENSIONS	

DIMENSION STYLE		SCALE	DESIGN UNITS	THIRD ANGLE PROJECTION
MM ONLY		1:1	METRIC	
DRAWN BY	DATE	TITLE		
WY. YANG	1992/09/14	7.3 PITCH W/W MALE HOUSING-6P		
CHECKED BY	DATE	MOLEX INCORPORATED		
BK. CHOI	1992/09/14	SD-35150-061*		
APPROVED BY	DATE	SHEET NO. 1 OF 01		
MATERIAL NO.	DOCUMENT NO.	THIS DRAWING CONTAINS INFORMATION THAT IS PROPRIETARY TO MOLEX INCORPORATED AND SHOULD NOT BE USED WITHOUT WRITTEN PERMISSION		
SEE TABLE				