

PLEASE CHECK WWW.MOLEX.COM FOR LATEST PART INFORMATION

Part Number: [0351500310](#)
Status: **Active**
Overview: [versablade](#)
Description: 7.30mm (.287") Pitch Wire-to-Wire VersaBlade™ Hybrid Plug Housing, with Mounting Ears, 3 Circuits, Polyester UL94V-0, Natural

Documents:

[3D Model](#) [RoHS Certificate of Compliance \(PDF\)](#)
[Drawing \(PDF\)](#)

Agency Certification

CSA	LR19980
TUV	R72090206
UL	E29179

General

Product Family	Crimp Housings
Series	35150
Comments	Polarized to Mating Part, Positive Lock
Overview	versablade
Product Name	VersaBlade™

Physical

Circuits (maximum)	3
Color - Resin	Natural
Flammability	94V-0
Gender	Female
Glow-Wire Compliant	No
Keying to Mating Part	None
Lock to Mating Part	Yes
Material - Resin	Polyester
Number of Rows	1
Packaging Type	Bag
Panel Mount	Yes
Pitch - Mating Interface (in)	0.287 In
Pitch - Mating Interface (mm)	7.30 mm
Polarized to Mating Part	Yes
Stackable	No
Temperature Range - Operating	-40°C to +120°C

Electrical

Current - Maximum per Contact	15A
-------------------------------	-----

Material Info

Reference - Drawing Numbers

Sales Drawing	SD-35150-031*
---------------	---------------

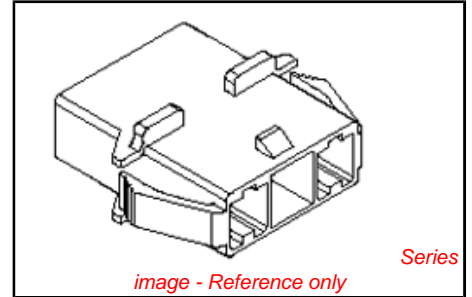

EU RoHS

ELV and RoHS Compliant
REACH SVHC
 Not Reviewed
Halogen-Free Status
 Not Reviewed

China RoHS



Need more information on product environmental compliance?

Email productcompliance@molex.com
 For a multiple part number RoHS Certificate of Compliance, [click here](#)

Please visit the [Contact Us](#) section for any non-product compliance questions.

Search Parts in this Series
[35150Series](#)

Mates With
[35151-031*](#) Receptacle Housing

Use With
 VersaBlade™ Crimp Terminals, [35745](#) ,
[35747](#) , [35746](#) <BR [351500290](#) TPA™

PLEASE CHECK WWW.MOLEX.COM FOR LATEST PART INFORMATION

10 9 8 7 6 5 4 3 2 1

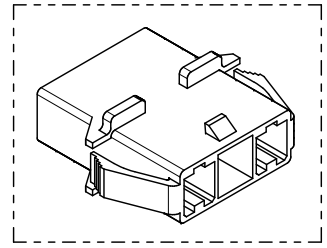

- NOTES.
1. MATERIAL & COLOR : SEE TABLE
 2. MATED HOUSING : 35151-031*
 3. APPLICABLE TERMINAL : 35745-0*10 (1 CIRCUIT)
35746-0*10 (2 CIRCUIT)
35747-0*10 (3 CIRCUIT)
 4. APPLICABLE T.P.A : 35150-039*
 5. PRODUCT SPECIFICATION : PS-35150-003

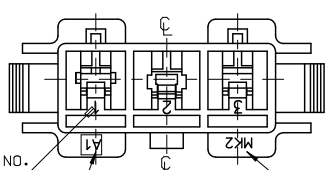
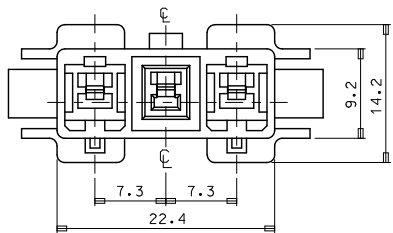
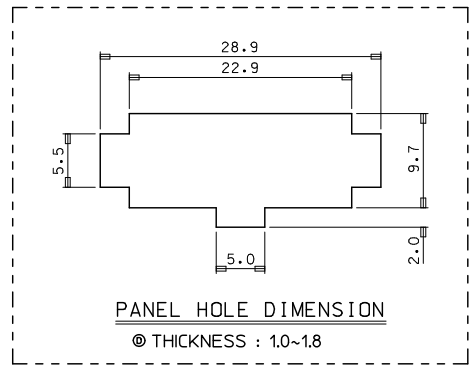

©TOOL NO & CAVITY NO (TOOL:A.B. CAV:1,2.)

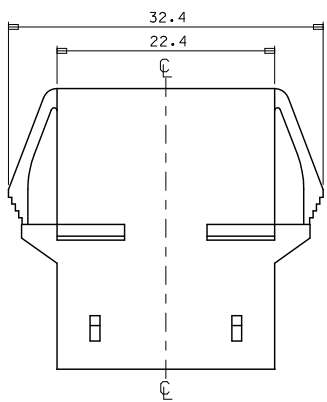
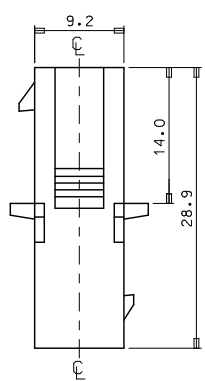

NO	PRODUCT		MATERIAL
	PART NO	COLOR	DESCRIPTION
1	35150-0310	NATURAL	POLYESTER (PBT) (UL94V-0)
2	35150-0314	BLUE	
3	35150-0319	NATURAL	PC/PET (UL94V-0)
4	35150-2319	RED	
5	35150-3319	YELLOW	
6	35150-4319	BLUE	

REVISED E.C. NO: KOR2010-0092 DRAWN: JHPARK01 2010/01/14 CHKD: W. YANG 2010/01/14 APPR: YUNSHKIM 2010/01/14	QUALITY SYMBOLS ▽=0 ▽=0	GENERAL TOLERANCES (UNLESS SPECIFIED)		DIMENSION STYLE MM ONLY		SCALE 1:1	DESIGN UNITS METRIC	THIRD ANGLE PROJECTION	
		4 PLACES ± --- ± --- 3 PLACES ± --- ± --- 2 PLACES ± --- ± --- 1 PLACE ± 0.3 ± ---	mm INCH	DRAWN BY JS. KANG	DATE	TITLE 7.3 PITCH W/W CONN MALE HSG-3P(W/EAR)			
		DRAFT WHERE APPLICABLE MUST REMAIN WITHIN DIMENSIONS		APPROVED BY	DATE	MOLEX INCORPORATED			
				MATERIAL NO. SEE TABLE	DATE	DOCUMENT NO. SD-35150-031*	SHEET NO. 1 OF 01		

THIS DRAWING CONTAINS INFORMATION THAT IS PROPRIETARY TO MOLEX INCORPORATED AND SHOULD NOT BE USED WITHOUT WRITTEN PERMISSION

9 8 7 6 5 4 3 2 1