

High-Voltage, 3-Channel Linear High-Brightness LED Driver with Open LED Detection

General Description

The MAX16823 three-channel LED driver operates from a 5.5V to 40V input voltage range and delivers up to 70mA per channel to one or more strings of high-brightness LEDs (HBLEDs). Each channel's current is programmable using an external current-sense resistor in series with the LEDs. Three DIM inputs allow a wide range of independent pulsed dimming in addition to providing the on and off control of the outputs. Wave-shaping circuitry reduces EMI while providing fast turn-on and turn-off times.

The MAX16823 is well suited for automotive applications requiring a high-voltage input and is able to withstand load-dump events up to 45V. On-board pass elements minimize external components while providing $\pm 5\%$ LED current accuracy. Additional features include an active-high, open-drain LEDGOOD output for open LED detection, a +3.4V ($\pm 5\%$) regulated output with 4mA output current capability, short-circuit and thermal protections.

The MAX16823 is available in thermally enhanced 5mm x 5mm, 16-pin TQFN-EP and 16-pin TSSOP-EP packages and is specified over the -40°C to $+125^{\circ}\text{C}$ automotive temperature range.

Applications

Automotive Exterior: Rear Combination Lights (RCLs), CHMSL

Automotive Interior: RGB Ambient Lighting, Cluster Lighting, and LCD Backlighting

Emergency Vehicle Warning Lights

Navigation and Marine Indicators

Architectural and Industrial Lighting

Features

- ◆ 5.5V to 40V Operating Range
- ◆ Adjustable Constant Output Current (5mA to 70mA and Up to 2A with External BJT)
- ◆ $\pm 5\%$ Output Current Accuracy
- ◆ Open LED Detection
- ◆ Three Independent High-Voltage DIM Inputs
- ◆ Three Integrated Pass Elements with Low Dropout Voltage (0.7V max)
- ◆ Undervoltage Lockout
- ◆ Output Short-Circuit Protection
- ◆ 3.4V Voltage Regulator with 4mA Capability
- ◆ Accurate, Low 203mV Current Sense
- ◆ Overtemperature Shutdown
- ◆ -40°C to $+125^{\circ}\text{C}$ Operating Temperature Range

Ordering Information

PART	TEMP RANGE	PIN-PACKAGE	PKG CODE
MAX16823ATE+	-40°C to $+125^{\circ}\text{C}$	16 TQFN-EP*	T1655-3
MAX16823AUE+	-40°C to $+125^{\circ}\text{C}$	16 TSSOP-EP*	U16E-3

+ Denotes a lead-free package.

*EP = Exposed pad.

Pin Configurations appear at end of data sheet.

Typical Operating Circuit

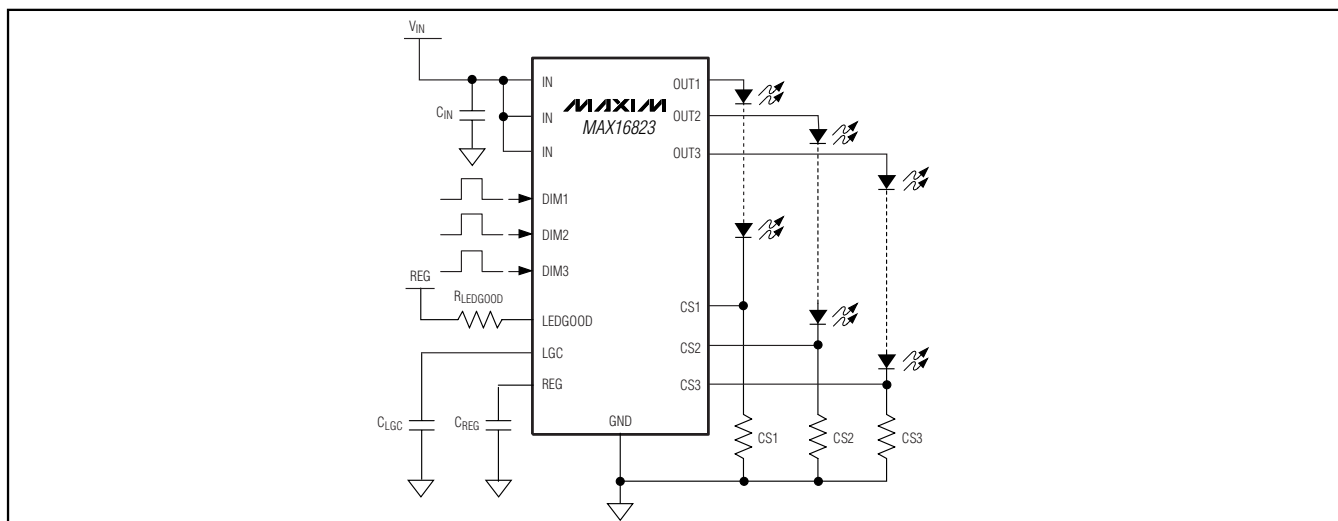

High-Voltage, 3-Channel Linear High-Brightness LED Driver with Open LED Detection

ABSOLUTE MAXIMUM RATINGS

IN to GND	-0.3V to +45V	Continuous Power Dissipation ($T_A = +70^\circ\text{C}$)
OUT1, OUT2, OUT3, DIM1, DIM2, DIM3 to GND	-0.3V to ($V_{IN} + 0.3\text{V}$)	16-Pin TQFN 5mm x 5mm (derate 33.3mW/ $^\circ\text{C}$ above $+70^\circ\text{C}$).....
REG, LGC, LEDGOOD to GND	-0.3V to +6V	2666mW
CS1, CS2, CS3 to GND	-0.3V to +0.5V	16-Pin TSSOP (derate 26.1mW/ $^\circ\text{C}$ above $+70^\circ\text{C}$)
OUT1, OUT2, OUT3 Short Circuited to GND Duration ($V_{IN} + 16\text{V}$)	60min	2088.8mW
Maximum Current into Any Pin (except IN, OUT1, OUT2, OUT3).....	$\pm 20\text{mA}$	Operating Temperature Range
		-40 $^\circ\text{C}$ to +125 $^\circ\text{C}$
		Junction Temperature
		+150 $^\circ\text{C}$
		Storage Temperature Range
		-65 $^\circ\text{C}$ to +150 $^\circ\text{C}$
		Lead Temperature (soldering, 10s)
		+300 $^\circ\text{C}$

Stresses beyond those listed under "Absolute Maximum Ratings" may cause permanent damage to the device. These are stress ratings only, and functional operation of the device at these or any other conditions beyond those indicated in the operational sections of the specifications is not implied. Exposure to absolute maximum rating conditions for extended periods may affect device reliability.

ELECTRICAL CHARACTERISTICS

($V_{IN} = 12\text{V}$, $C_{REG} = 0.1\mu\text{F}$, $I_{REG} = 0$, $C_{LGC} = 15\text{nF}$, $V_{DIM1} = V_{DIM2} = V_{DIM3} = 3.4\text{V}$, $R_{CS_} = 2.85\Omega$ from $CS_$ to GND, $T_J = T_A = -40^\circ\text{C}$ to $+125^\circ\text{C}$, unless otherwise noted. Typical values are at $T_A = +25^\circ\text{C}$.) (Note 1)

PARAMETER	SYMBOL	CONDITIONS	MIN	TYP	MAX	UNITS
Supply Voltage Range	V_{IN}		5.5		40	V
Undervoltage Lockout	UVLO	V_{IN} rising	4.4	4.9	5.4	V
		V_{IN} falling	4.0	4.6	5.2	
Ground Current	I_G	$I_{OUT1} = I_{OUT2} = I_{OUT3} = 70\text{mA}$		1.5	3	mA
Guaranteed Output Current	I_{OUT}		70			mA
LED Current-Sense Accuracy		$5\text{mA} \leq I_{OUT_} \leq 70\text{mA}$			5	%
Dropout Voltage (Note 2)	ΔV_{DO}	$I_{OUT_} = 70\text{mA}$, $6.5\text{V} \leq V_{IN} \leq 40\text{V}$		0.3	0.7	V
		$I_{OUT_} = 70\text{mA}$, $5.5\text{V} \leq V_{IN} \leq 6.5\text{V}$		0.3	0.8	
Output Current Slew Rate				8		mA/ μs
Short-Circuit Current		$V_{OUT_} = 0\text{V}$		180		mA
LEDGOOD						
LEDGOOD Output Logic Low	V_{OL}	$I_{SINK} = 2\text{mA}$			0.4	V
LGC Pullup Resistor			65	100	135	k Ω
LGC Input Upper Threshold	V_{UTH}			2.53		V
LGC Input Lower Threshold	V_{LTH}			0.8		V
LGC Pulldown Current		$V_{LGC} > V_{UTH}$		20		mA
LGC Clock Period		$C_{LGC} = 15\text{nF}$	0.77	1.5	2.3	ms
DIMMING INPUT (DIM1, DIM2, DIM3)						
DIM_ Logic-Input Bias Current	$I_{DIM_}$		-0.1		+0.1	μA
DIM_ Input-Voltage High			2.4		V_{IN}	V
DIM_ Input-Voltage Low					0.6	V
DIM_ Frequency			0		3	kHz
OUTPUTS (OUT1, OUT2, AND OUT3) (Note 3)						
Turn-On Time		DIM_ rising edge to 90% of $I_{OUT_}$ current		12	28	μs
Turn-Off Time		DIM_ falling edge to 10% of $I_{OUT_}$ current		8	18	μs
Output Current Rise Time		10% to 90%		7	18	μs
Output Current Fall Time		90% to 10%		6	15	μs

High-Voltage, 3-Channel Linear High-Brightness LED Driver with Open LED Detection

ELECTRICAL CHARACTERISTICS (continued)

($V_{IN} = 12V$, $C_{REG} = 0.1\mu F$, $I_{REG} = 0$, $C_{LGC} = 15nF$, $V_{DIM1} = V_{DIM2} = V_{DIM3} = 3.4V$, $R_{CS_} = 2.85\Omega$ from $CS_$ to GND, $T_J = T_A = -40^\circ C$ to $+125^\circ C$, unless otherwise noted. Typical values are at $T_A = +25^\circ C$.) (Note 1)

PARAMETER	SYMBOL	CONDITIONS	MIN	TYP	MAX	UNITS
CURRENT SENSE						
Regulated $CS_$ Voltage	$V_{CS_}$	$5mA \leq I_{OUT_} \leq 70mA$	193	203	213	mV
Input Current ($CS1, CS2, CS3$)		Current out of $CS_$			+1.2	μA
OVERTEMPERATURE PROTECTION (Note 4)						
Thermal Shutdown Temperature				155		$^\circ C$
Thermal Shutdown Hysteresis				23		$^\circ C$
3.4V REGULATOR (REG)						
Output Voltage	V_{REG}		3.275	3.41	3.547	V
		$0 \leq I_{REG} \leq 4mA$	3.221	3.38	3.547	
REG Short-Circuit Current		$V_{REG} = 0V$		13		mA

Note 1: All devices 100% production tested at $T_J = +25^\circ C$. Limits over the operating temperature range are guaranteed by design.

Note 2: Dropout is measured as follows: Connect a resistor from $OUT_$ to $CS_$. Connect $R_{CS_} = 2.85\Omega$ from $CS_$ to GND. Set $V_{IN} = V_{OUT} + 3V$ (record V_{OUT} as V_{OUTA}). Reduce V_{IN} until $V_{OUT} = 0.97 \times V_{OUTA}$ (record as V_{INB} and V_{OUTB}). $VDO = V_{INB} - V_{OUTB}$.

Note 3: Output current rise and fall times are measured with a 62Ω series resistor from $OUT_$ to $CS_$.

Note 4: Overtemperature protection does not function if the output of the 3.4V reference (REG) is shorted to ground.

Typical Operating Characteristics

($V_{IN} = 12V$, $C_{REG} = 0.1\mu F$, $I_{REG} = 0$, $V_{LGC} =$ unconnected, connect $R_{CS_} = 2.85\Omega$ from $CS_$ to GND. Connect $OUT_$ to $CS_$ through a resistor, $T_J = -40^\circ C$ to $+125^\circ C$, unless otherwise noted. Typical values are at $T_A = +25^\circ C$.)

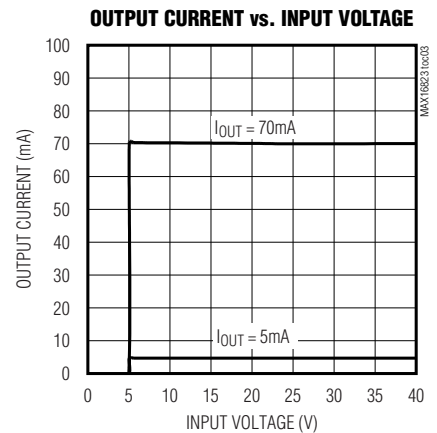
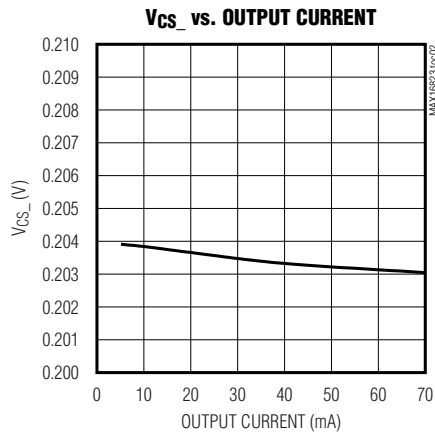
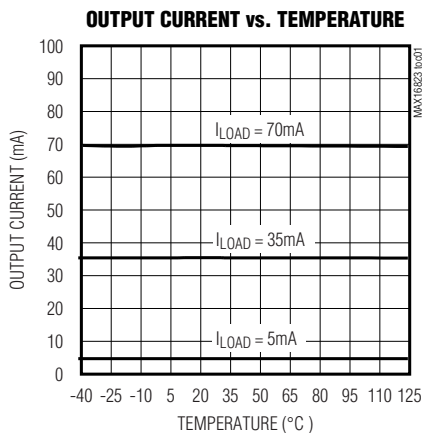

High-Voltage, 3-Channel Linear High-Brightness LED Driver with Open LED Detection

Typical Operating Characteristics (continued)

($V_{IN} = 12V$, $C_{REG} = 0.1\mu F$, $I_{REG} = 0$, $V_{LGC} =$ unconnected, connect $R_{CS} = 2.85\Omega$ from CS_{-} to GND. Connect OUT_{-} to CS_{-} through a resistor, $T_J = -40^{\circ}C$ to $+125^{\circ}C$, unless otherwise noted. Typical values are at $T_A = +25^{\circ}C$.)

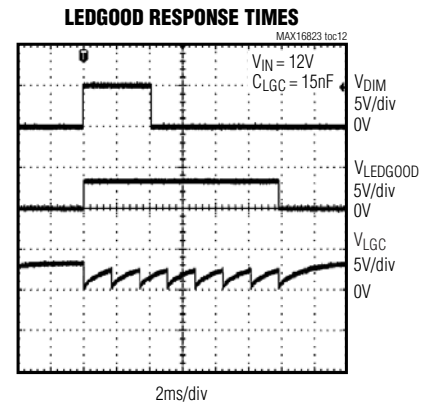
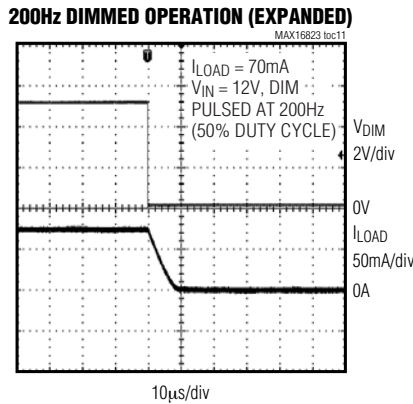
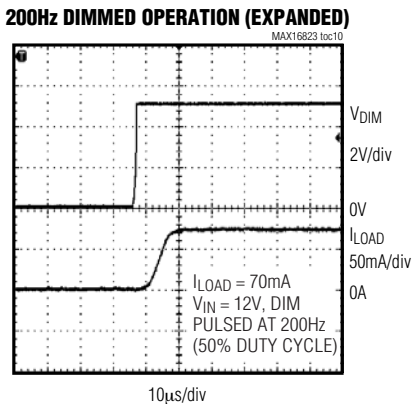
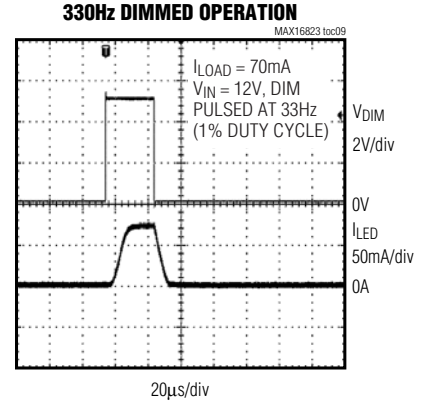
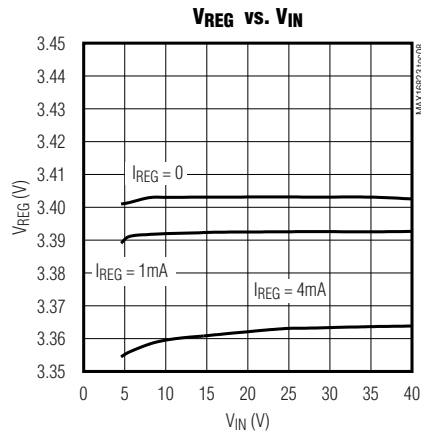
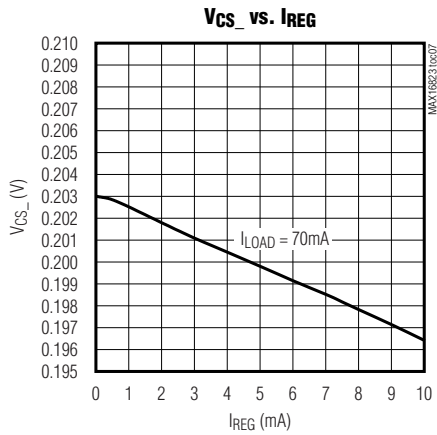
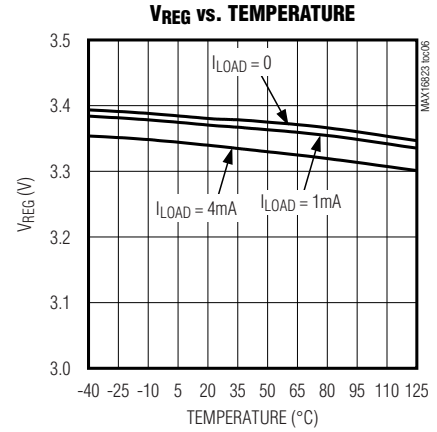
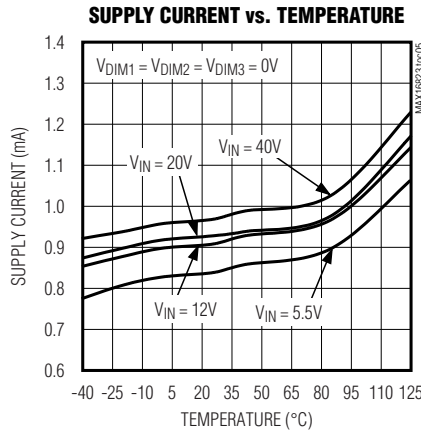
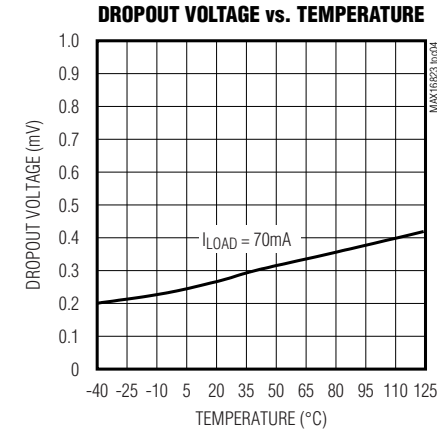

High-Voltage, 3-Channel Linear High-Brightness LED Driver with Open LED Detection

Pin Description

MAX16823

PIN		NAME	FUNCTION
TQFN	TSSOP		
1	3	DIM1	Dimming Input 1. DIM1 is a low-frequency dimming input for channel 1. A logic-low turns off OUT1 and a logic-high turns on OUT1.
2	4	DIM2	Dimming Input 2. DIM2 is a low-frequency dimming input for channel 2. A logic-low turns off OUT2 and a logic-high turns on OUT2.
3	5	DIM3	Dimming Input 3. DIM3 is a low-frequency dimming input for channel 3. A logic-low turns off OUT3 and a logic-high turns on OUT3.
4	6	LEDGOOD	Open LED Output. LEDGOOD is an open-drain output. A logic-high indicates the LED connection is good in all three channels. A logic-low indicates an open LED connection. See the <i>LEDGOOD</i> section.
5, 6, 7	7, 8, 9	IN	Positive Input Supply. Bypass with a 0.1 μ F (min) capacitor to GND. Connect all IN pins together.
8	10	LGC	LED Detection-Timing Setting. Connect a capacitor from LGC to ground to set the delay time for LEDGOOD.
9	11	REG	3.4V Voltage Regulator. Connect a 0.1 μ F capacitor from REG to GND.
10	12	GND	Ground
11	13	CS3	Channel 3 Sense Amplifier Positive Input. Connect the current-sense resistor between CS3 and GND to program the output current level for channel 3.
12	14	CS2	Channel 2 Sense Amplifier Positive Input. Connect the current-sense resistor between CS2 and GND to program the output current level for channel 2.
13	15	CS1	Channel 1 Sense Amplifier Positive Input. Connect the current-sense resistor between CS1 and GND to program the output current level for channel 1.
14	16	OUT3	Current Regulator Output 3
15	1	OUT2	Current Regulator Output 2
16	2	OUT1	Current Regulator Output 1
EP	EP	EP	Exposed Pad. Connect EP to a large-area ground plane for effective power dissipation. Do not use as the IC ground connection.

High-Voltage, 3-Channel Linear High-Brightness LED Driver with Open LED Detection

Detailed Description

The MAX16823 three-channel current regulator operates from a 5.5V to 40V input voltage range and delivers up to 70mA per channel to one or more strings of HBLEDs. The output currents are programmable using external current-sense resistors in series with the LEDs. Three DIM inputs allow a wide range of independent pulsed dimming in addition to providing the on and off control of the outputs. The MAX16823 offers an LEDGOOD output that indicates an open-circuit condition when one or more LED channels are open.

Integrated pass elements minimize external components while providing $\pm 5\%$ output current accuracy. Additional features include a 3.4V ($\pm 5\%$) voltage regulator with 4mA output current capability, short-circuit and thermal protection.

The MAX16823 uses a feedback loop to linearly control the current from each output. The voltage across each sense resistor is compared to a fixed reference voltage and the error is amplified to drive the internal power pass device for a particular channel. See the *Block Diagram*. The regulation point is factory-set at 203mV. The regulated current is adjusted by the value of $R_{CS_}$.

The MAX16823 is a constant-current LED driver internally optimized for driving the impedance range expected from one or more HBLEDs.

3.4V Regulator (REG)

The MAX16823 includes a fixed 3.4V voltage regulator that delivers up to 4mA of load current for auxiliary applications throughout the 5.5V to 40V input voltage range. Connect a 0.1 μ F compensation capacitor from REG to ground. Shorting REG to ground disables the thermal shutdown.

Thermal Protection

The MAX16823 enters a thermal-shutdown mode in the event of overheating. This typically occurs in overload or output short-circuit conditions. When the junction temperature exceeds $T_J = +155^\circ\text{C}$, the internal thermal protection circuitry turns off the series pass elements. The MAX16823 recovers from thermal-shutdown mode once the junction temperature drops by 23°C . The part will therefore protect itself by low-frequency thermal cycling in the event of a short-circuit or overload condition.

Applications Information

Programming the LED Current

The MAX16823 uses sense resistors to set the output current for each channel. To set the LED current for a particular channel, connect a sense resistor across the corresponding current-sense input ($CS_$) and GND. For optimal accuracy, connect the low-side of the current-sense resistors to the IC's ground pin with short traces. The value needed for the sense resistor for a given current can be calculated with the equation below:

$$R_{CS_}(\Omega) = \frac{V_{CS_}(V)}{I_{OUT_}(A)}$$

where $V_{CS_}$ is 203mV and $I_{OUT_}$ is the desired LED current (I_{LED}).

Input-Voltage Considerations

For proper operation, the minimum input voltage must always be:

$$V_{IN(MIN)} \geq V_{CS_}(MAX) + V_{FT}(MAX) + V_{DO}(MAX)$$

where $V_{FT}(MAX)$ is the total forward voltage of all series-connected LEDs. The minimum operating voltage of the device is 5.5V.

LEDDOOD

The MAX16823 features an active-low, open-drain LEDGOOD output that goes low either when one or more LED channels are open or when a signal at any of the dimming inputs remains low for a period greater than the programmed LEDGOOD delay time t_{DELAY} . Program t_{DELAY} with a capacitor connected between LGC and ground. The LEDGOOD output goes low after the programmed delay period t_{DELAY} has elapsed. Use the following formula to set the delay period:

$$t_{DELAY} = 257,900(\Omega) \times C_{LGC}(F)$$

where C_{LGC} is the capacitor connected between LGC and ground. The LEDGOOD output goes low during the thermal shutdown.

High-Voltage, 3-Channel Linear High-Brightness LED Driver with Open LED Detection

Block Diagram

MAX16823

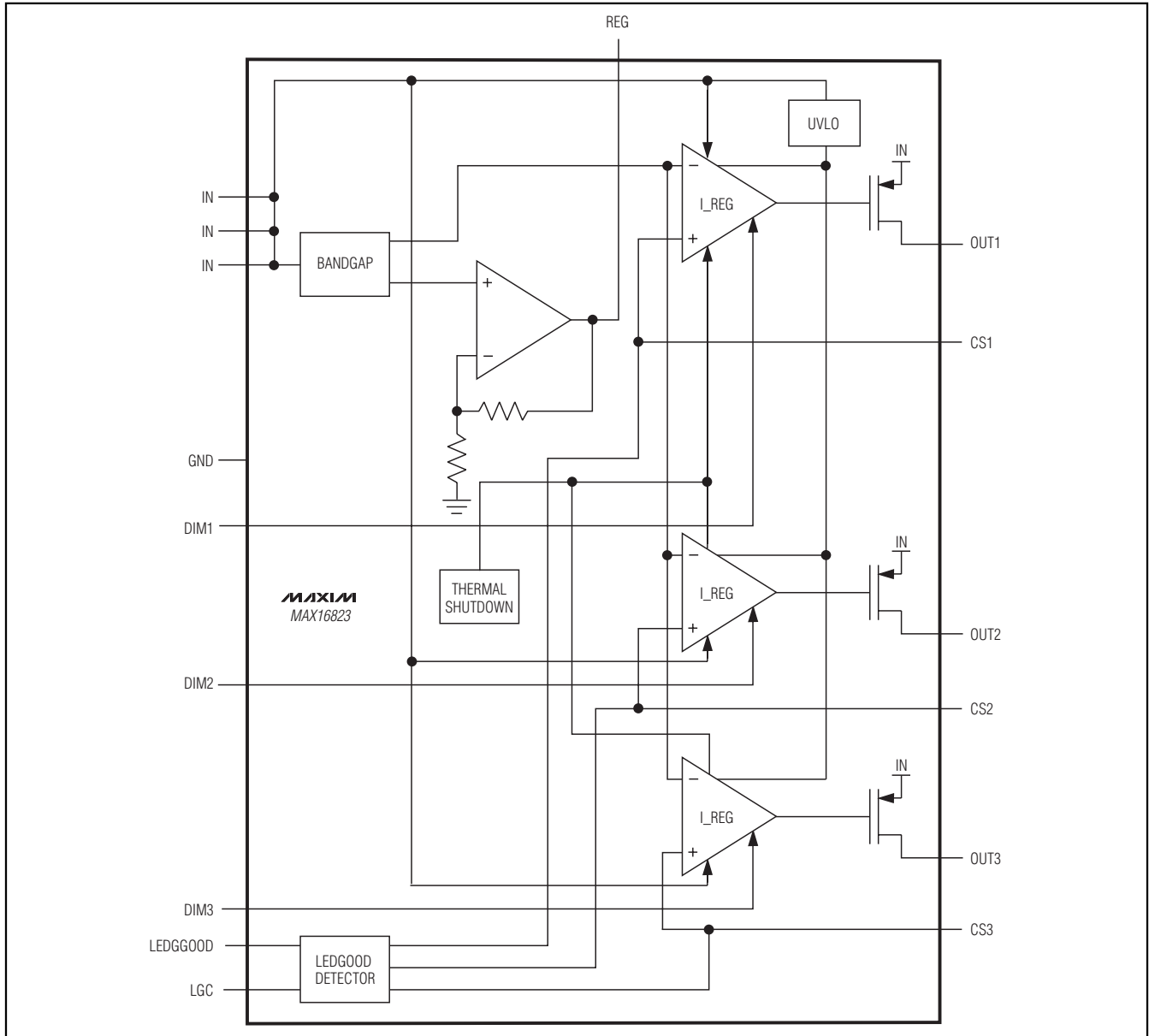

Pulse-Dimming Inputs (DIM_n)

The MAX16823 features pulsed or chopped-current dimming inputs (DIM_n) to chop the LED current and to adjust the brightness. DIM_n also serves as an active-high enable input. A logic-low at DIM_n turns off OUT_n and a logic-high turns on OUT_n. If the signal at DIM_n stays low more than the programmed LEDGOOD delay time, LEDGOOD goes low (Figure 1).

Two Brightness Levels for TAIL/STOP Lights

Figure 2 shows the PWM dimming operation for the MAX16823 with an ICM7555 timer. The ICM7555 provides an adjustable duty cycle using two external resistors and a capacitor. In TAIL operation, the output of the ICM7555 feeds into DIM and lights up the LEDs. The LED's brightness depends on the duty cycle of the

High-Voltage, 3-Channel Linear High-Brightness LED Driver with Open LED Detection

ICM7555. When V_{STOP} is present, DIM is pulled up to V_{STOP} . The PWM dimming operation is disabled and the LEDs light up to full brightness. See the ICM7555 data sheet for formulas to calculate the dimming frequency and the duty cycle.

Outputs Latch-Off

Figure 3 shows a circuit with DIM1, DIM2, DIM3, and LEDGOOD connected through a resistor to V_{REG} . This circuit is useful for applications that require all outputs to latch off when one of the LEDs opens. The MAX16823 resumes current regulation again through power cycling, once the fault condition is removed.

Other Applications

The application circuit in Figure 4 implements a two-level brightness current for TAIL/STOP lights. In TAIL operation, Q1 is off and R_{CS1} sets the output current. In STOP operation, Q1 turns on and the output current is set by a parallel combination of R_{CS1} and R2.

Figure 5 shows an application circuit with the MAX16823 using a single BJT to provide high output current. For proper operation:

$$V_{IN(MIN)} > V_{BE(MAX)} + V_{FT(MAX)} + V_{CS_} + V_{DO(MAX)}$$

For minimized dropout, the LEDs can be placed in the collector.

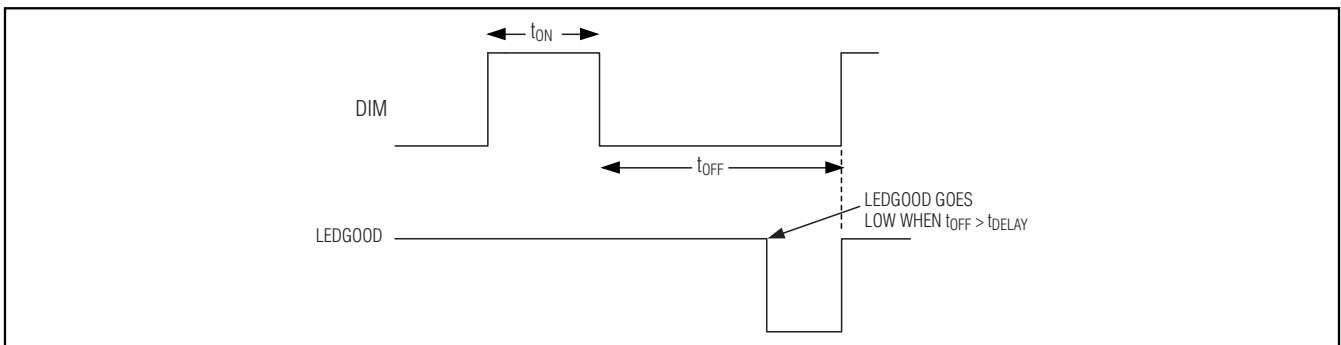

Figure 1. LEDGOOD Timing Delay

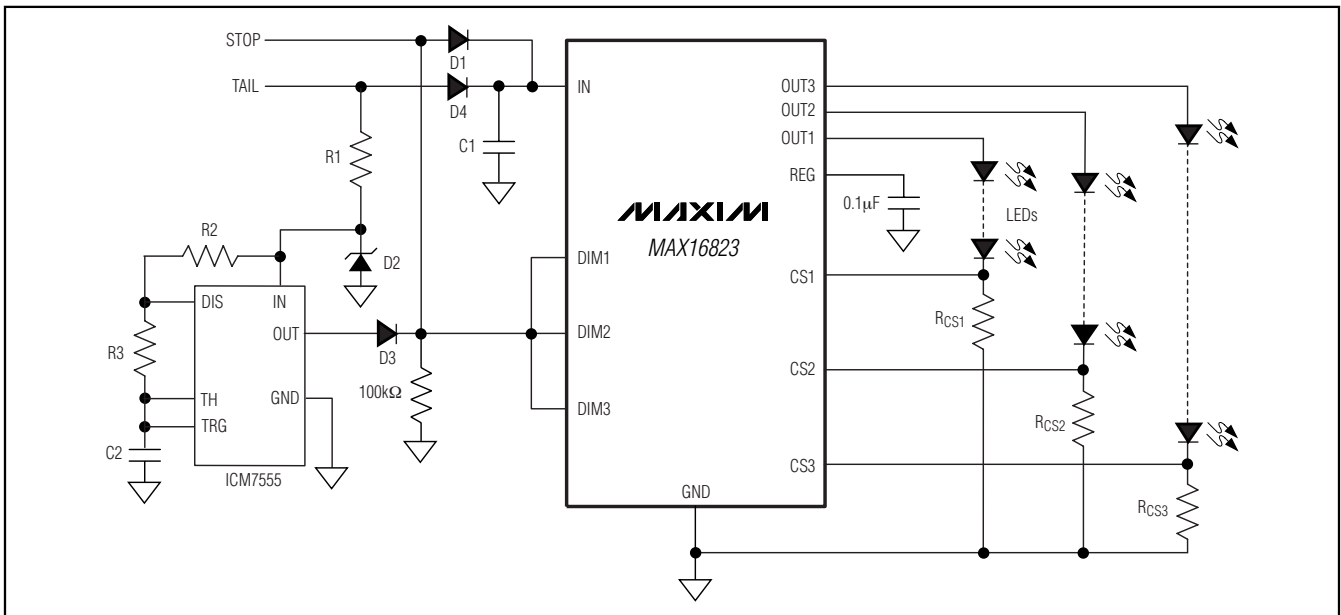

Figure 2. PWM Dimming Operation with ICM7555

High-Voltage, 3-Channel Linear High-Brightness LED Driver with Open LED Detection

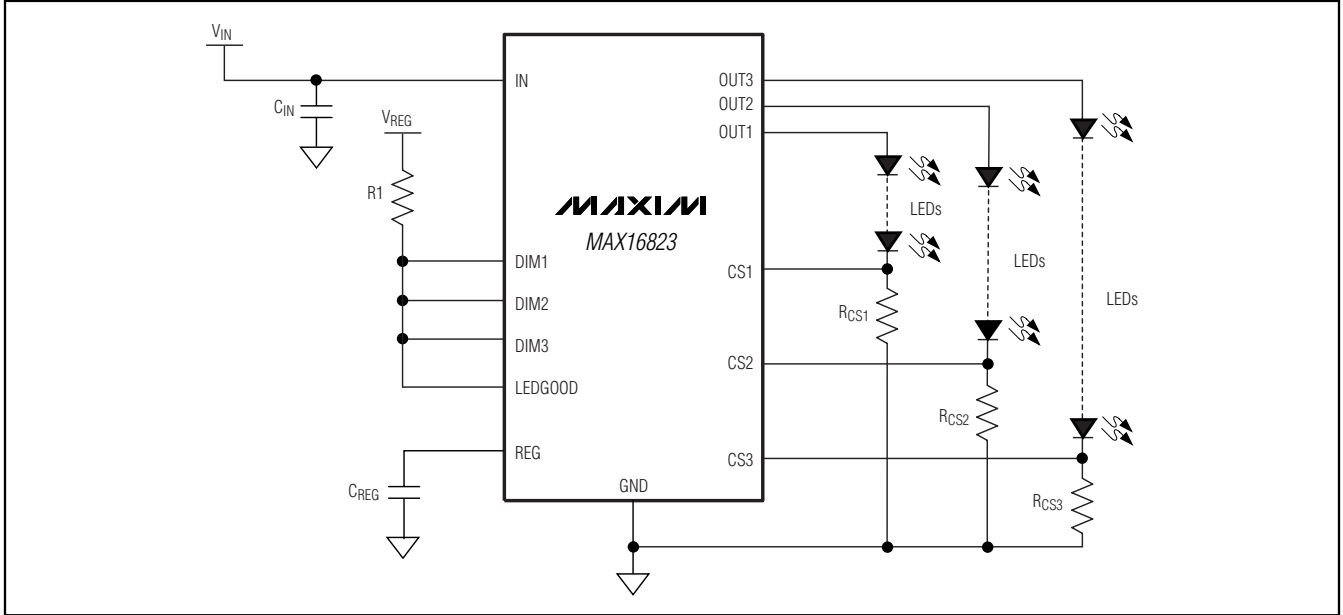
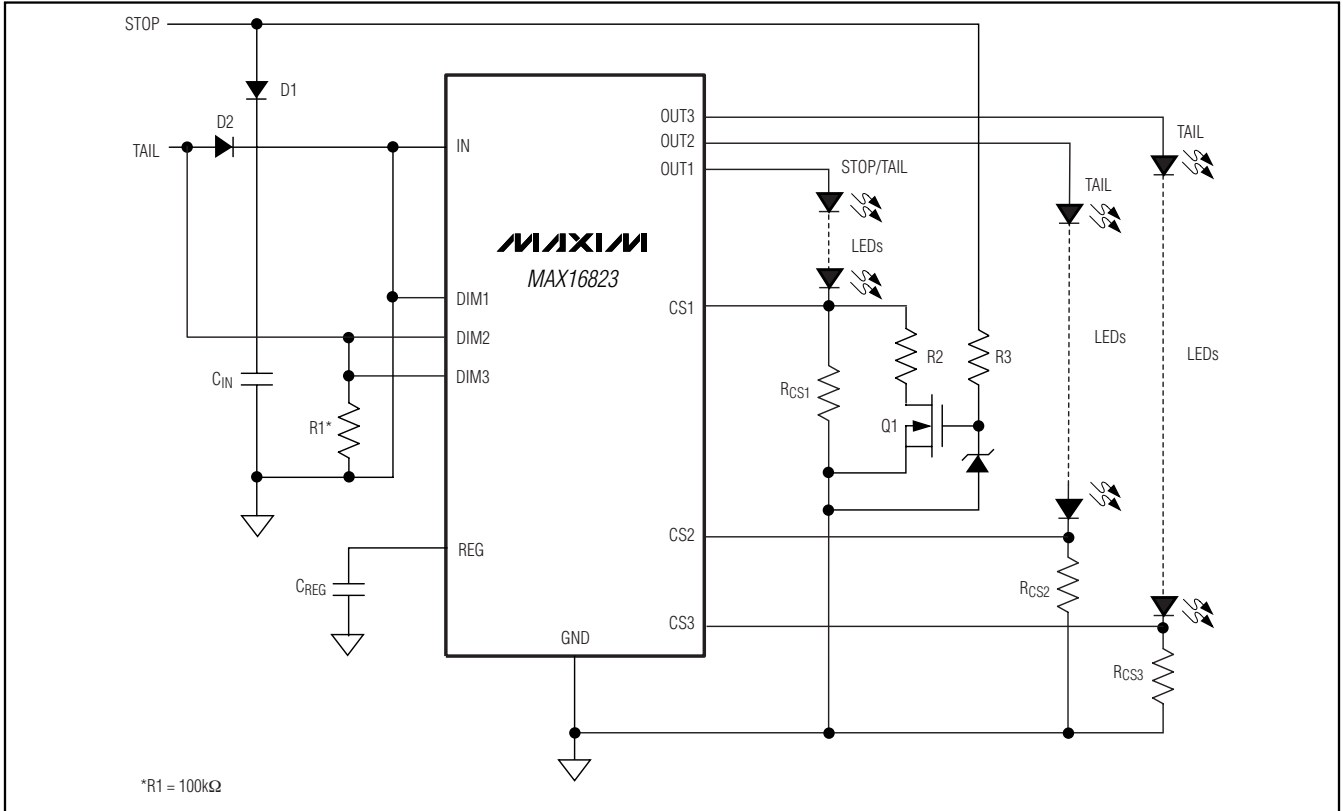

Figure 3. Output_Latch-Off



*R1 = 100kΩ

Figure 4. Two-Brightness Level with Current Level Switch for TAIL/STOP Lights

High-Voltage, 3-Channel Linear High-Brightness LED Driver with Open LED Detection

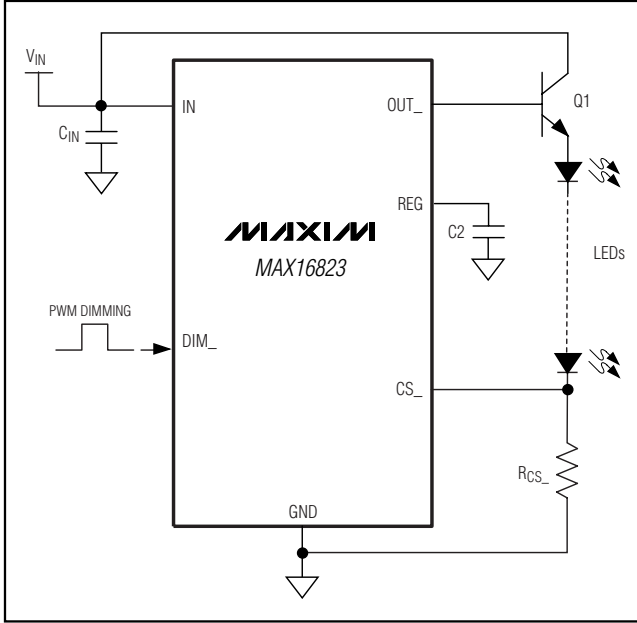

Figure 5. Increased LED Current (Amper Range) with a Single BJT

Preload Current

Figure 6 shows the MAX16823 with a preload circuit. In the circuit, the BJT, RPRELOAD, and REG generate a preset load current. The preset load current I_{PRESET} is determined with the following formula:

$$I_{PRESET} = \frac{V_{REG} - 0.7V}{R_{PRELOAD}}$$

This circuit is used with older body controllers that monitor minimum RCL current to detect failures.

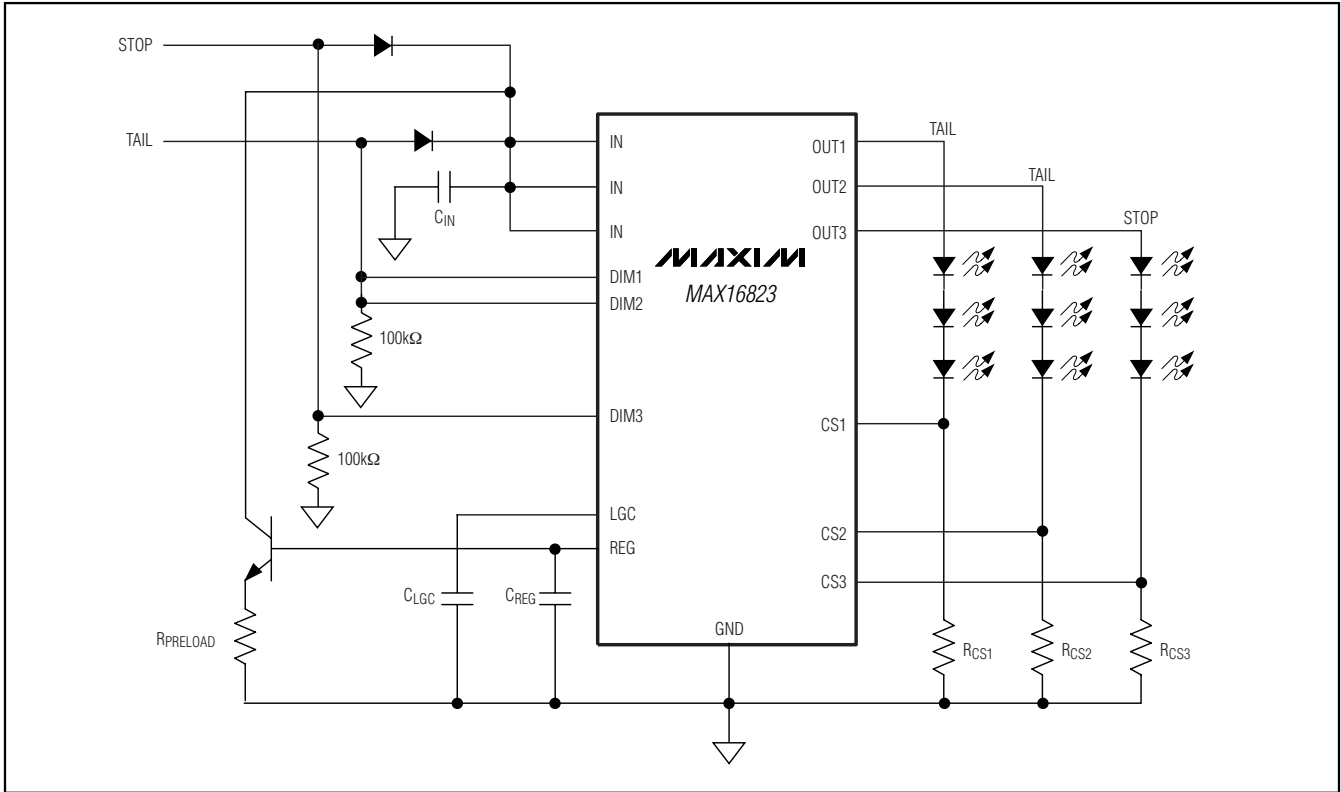
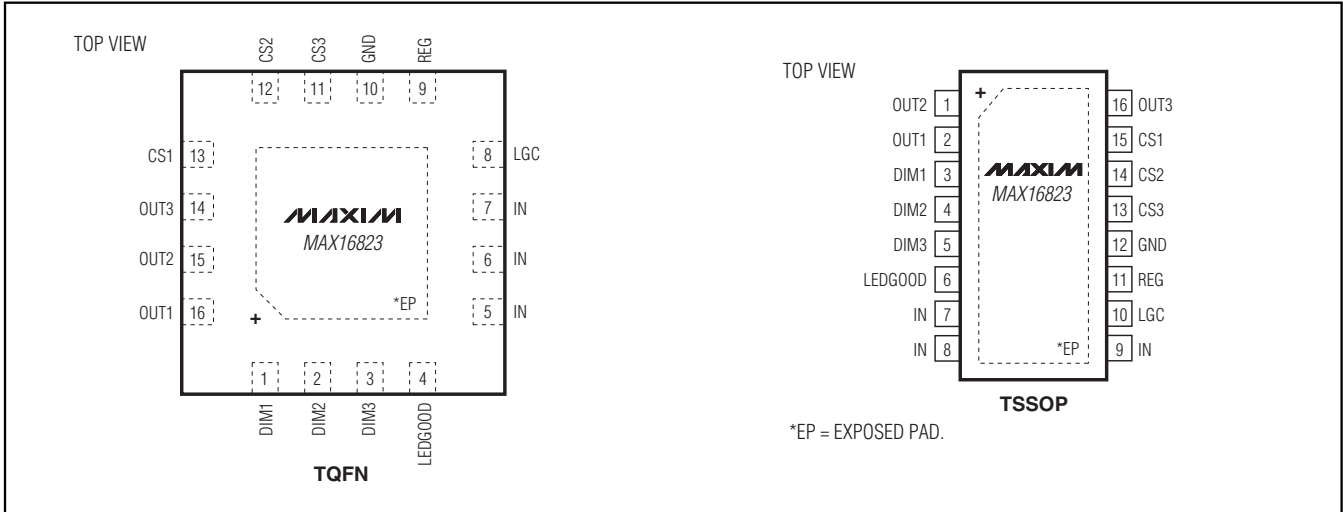

Figure 6. Preload Current Setting

High-Voltage, 3-Channel Linear High-Brightness LED Driver with Open LED Detection

Pin Configurations

MAX16823



Chip Information

PROCESS: BiCMOS-DMOS

High-Voltage, 3-Channel Linear High-Brightness LED Driver with Open LED Detection

Package Information

(The package drawing(s) in this data sheet may not reflect the most current specifications. For the latest package outline information go to www.maxim-ic.com/packages.)

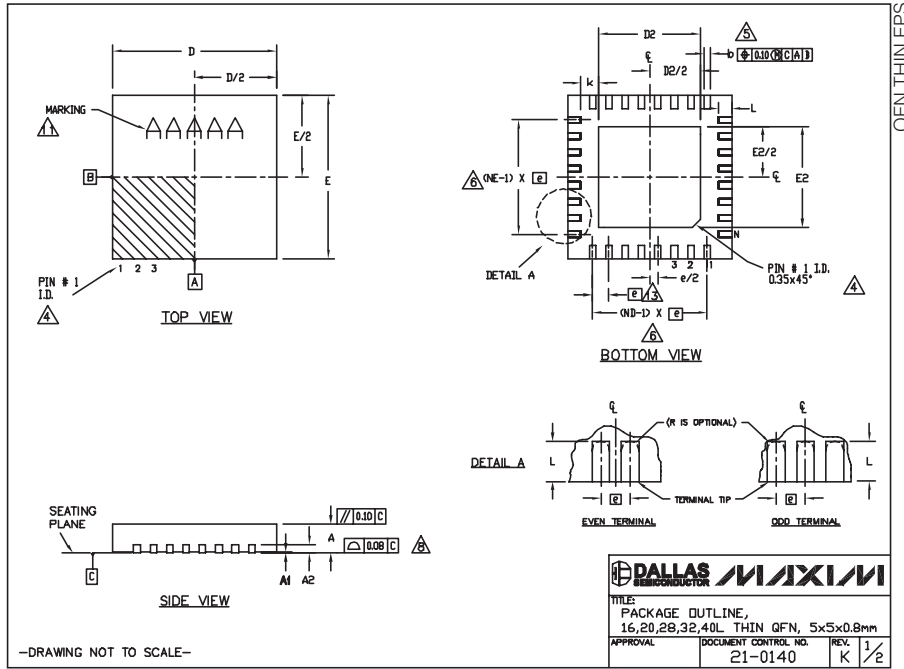

COMMON DIMENSIONS												
PKG SYMBOL	16L 5x5			20L 5x5			28L 5x5			40L 5x5		
	MIN.	NOM.	MAX.	MIN.	NOM.	MAX.	MIN.	NOM.	MAX.	MIN.	NOM.	MAX.
A	0.70	0.75	0.80	0.70	0.75	0.80	0.70	0.75	0.80	0.70	0.75	0.80
A1	0	0.02	0.05	0	0.02	0.05	0	0.02	0.05	0	0.02	0.05
A2	0.20 REF.			0.20 REF.			0.20 REF.			0.20 REF.		
b	0.25	0.30	0.35	0.25	0.30	0.35	0.25	0.30	0.25	0.30	0.15	0.20
D	4.90	5.20	5.10	4.90	5.00	5.10	4.90	5.00	5.10	4.90	5.00	5.10
E	4.90	5.00	5.10	4.90	5.00	5.10	4.90	5.00	5.10	4.90	5.00	5.10
e	0.80 BSC.			0.65 BSC.			0.50 BSC.			0.50 BSC.		
k	0.25	-	0.25	-	0.25	-	0.25	-	0.25	-	0.25	-
L	0.30	0.40	0.50	0.45	0.55	0.65	0.45	0.55	0.65	0.30	0.40	0.50
N	16		20		28		32		40			
ND	4		5		7		8		10			
NE	4		5		7		8		10			
JEDEC	VHFB		VHHC		VHHD-1		VHHD-2		----			

PKG. CODES	D2			E2		
	MIN.	NOM.	MAX.	MIN.	NOM.	MAX.
T1655-2	3.00	3.10	3.20	3.00	3.10	3.20
T1655-3	3.00	3.10	3.20	3.00	3.10	3.20
T1655N-1	3.00	3.10	3.20	3.00	3.10	3.20
T2055-3	3.00	3.10	3.20	3.00	3.10	3.20
T2055-4	3.00	3.10	3.20	3.00	3.10	3.20
T2055-5	3.15	3.25	3.35	3.15	3.25	3.35
T2055M-5	3.15	3.25	3.35	3.15	3.25	3.35
T2855-3	3.15	3.25	3.35	3.15	3.25	3.35
T2855-4	2.60	2.70	2.80	2.60	2.70	2.80
T2855-5	2.60	2.70	2.80	2.60	2.70	2.80
T2855-6	3.15	3.25	3.35	3.15	3.25	3.35
T2855-7	2.60	2.70	2.80	2.60	2.70	2.80
T2855-8	3.15	3.25	3.35	3.15	3.25	3.35
T2855N-1	3.15	3.25	3.35	3.15	3.25	3.35
T3255-3	3.00	3.10	3.20	3.00	3.10	3.20
T3255-4	3.00	3.10	3.20	3.00	3.10	3.20
T3255M-4	3.00	3.10	3.20	3.00	3.10	3.20
T3255-5	3.00	3.10	3.20	3.00	3.10	3.20
T3255N-1	3.00	3.10	3.20	3.00	3.10	3.20
T4055-1	3.40	3.50	3.60	3.40	3.50	3.60
T4055-2	3.40	3.50	3.60	3.40	3.50	3.60

NOTES:

- DIMENSIONING & TOLERANCING CONFORM TO ASME Y14.5M-1994.
- ALL DIMENSIONS ARE IN MILLIMETERS. ANGLES ARE IN DEGREES.
- N IS THE TOTAL NUMBER OF TERMINALS.
- THE TERMINAL #1 IDENTIFIER AND TERMINAL NUMBERING CONVENTION SHALL CONFORM TO JEDEC 95-1 SFP-02. DETAILS OF TERMINAL #1 IDENTIFIER ARE OPTIONAL, BUT MUST BE LOCATED WITHIN THE ZONE INDICATED. THE TERMINAL #1 IDENTIFIER MAY BE EITHER A MOLD OR MARKED FEATURE.
- DIMENSION b APPLIES TO METALLIZED TERMINAL AND IS MEASURED BETWEEN 0.25 mm AND 0.30 mm FROM TERMINAL TIP.
- ND AND NE REFER TO THE NUMBER OF TERMINALS ON EACH D AND E SIDE RESPECTIVELY.
- DEPOPULATION IS POSSIBLE IN A SYMMETRICAL FASHION.
- COPLANARITY APPLIES TO THE EXPOSED HEAT SINK SLUG AS WELL AS THE TERMINALS.
- DRAWING CONFORMS TO JEDEC MO220, EXCEPT EXPOSED PAD DIMENSION FOR T2855-3, T2855-6, T4055-1 AND T4055-2.
- VARPAGE SHALL NOT EXCEED 0.10 mm.
- MARKING IS FOR PACKAGE ORIENTATION REFERENCE ONLY.
- NUMBER OF LEADS SHOWN ARE FOR REFERENCE ONLY.
- LEAD CENTERLINES TO BE AT TRUE POSITION AS DEFINED BY BASIC DIMENSION 'e', ±0.05.

-DRAWING NOT TO SCALE-

DALLAS SEMICONDUCTOR **MAXIM**

TITLE: PACKAGE OUTLINE, 16,20,28,32,40L THIN QFN, 5x5x0.8mm

APPROVAL: _____ DOCUMENT CONTROL NO. 21-0140 REV. K 1/2

High-Voltage, 3-Channel Linear High-Brightness LED Driver with Open LED Detection

Package Information (continued)

(The package drawing(s) in this data sheet may not reflect the most current specifications. For the latest package outline information go to www.maxim-ic.com/packages.)

MAX16823

SYMBOL	COMMON DIMENSIONS			
	MILLIMETERS		INCHES	
A	MIN.	MAX.	MIN.	MAX.
A	--	1.10	--	0.043
A1	0.00	0.15	0.000	0.006
A2	0.85	0.95	0.033	0.037
b	0.19	0.30	0.007	0.012
b1	0.19	0.25	0.007	0.010
c	0.090	0.20	0.004	0.008
c1	0.090	0.135	0.004	0.0053
D	SEE VARIATIONS		SEE VARIATIONS	
E	4.30	4.50	0.169	0.177
e	0.65 BSC		0.026 BSC	
H	6.25	6.50	0.246	0.256
L	0.50	0.70	0.020	0.028
N	SEE VARIATIONS		SEE VARIATIONS	
Y	2.85	3.15	0.112	0.124
α	0°	8°	0°	8°

JEDEC	N	VARIATIONS				
		MILLIMETERS		INCHES		
MD-153	N	MIN.	MAX.	MIN.	MAX.	
ABT-1	14	D	4.90	5.10	0.193	0.201
		X	2.95	3.25	0.116	0.128
ABT	16	D	4.90	5.10	0.193	0.201
		X	2.85	3.15	0.112	0.124
ACT	20	D	6.40	6.60	0.252	0.260
		X	4.00	4.34	0.157	0.171
AET	28	D	9.60	9.80	0.378	0.386
		X	5.35	5.65	0.211	0.222

NOTES:

- DIMENSIONS D AND E DO NOT INCLUDE FLASH.
- MOLD FLASH OR PROTRUSIONS NOT TO EXCEED 0.15mm PER SIDE.
- CONTROLLING DIMENSION: MILLIMETERS.
- MEETS JEDEC OUTLINE MD-153, SEE JEDEC VARIATIONS TABLE.
- "N" REFERS TO NUMBER OF LEADS.
- EXPOSED PAD FLUSH WITH BOTTOM OF PACKAGE WITHIN .002".
- THE LEAD TIPS MUST LIE WITHIN A SPECIFIED ZONE. THIS TOLERANCE ZONE IS DEFINED BY TWO PARALLEL PLANES. ONE PLANE IS THE SEATING PLANE, DATUM [-C-]; THE OTHER PLANE IS AT THE SPECIFIED DISTANCE FROM [-C-] IN THE DIRECTION INDICATED.
- MARKING IS FOR PACKAGE ORIENTATION REFERENCE ONLY.
- NUMBER OF LEADS SHOWN ARE FOR REFERENCE ONLY.

-DRAWING NOT TO SCALE-

DALLAS SEMICONDUCTOR **MAXIM**

TITLE: PACKAGE OUTLINE, TSSOP, 4.40 MM BODY, EXPOSED PAD

APPROVAL	DOCUMENT CONTROL NO. 21-0108	REV. E	1/1
----------	---------------------------------	-----------	-----

Revision History

Pages changed at Rev 1: 1, 13

Maxim cannot assume responsibility for use of any circuitry other than circuitry entirely embodied in a Maxim product. No circuit patent licenses are implied. Maxim reserves the right to change the circuitry and specifications without notice at any time.

Maxim Integrated Products, 120 San Gabriel Drive, Sunnyvale, CA 94086 408-737-7600 13

© 2007 Maxim Integrated Products

MAXIM is a registered trademark of Maxim Integrated Products, Inc.