

3.5A step down switching regulator

Features

- Up to 3.5A step down converter
- Operating input voltage from 8V to 55V
- 3.3V and 5.1V ($\pm 1\%$) fixed output, and adjustable outputs from:
 - 0.5V to 50V (3.3 type)
 - 5.1V to 50V (5.1 type)
- Frequency adjustable up to 300kHz
- Voltage feed forward
- Zero load current operation (min 1mA)
- Internal current limiting (pulse by pulse and HICCUP mode)
- Precise 5.1V (1.5%) reference voltage externally available
- Input/output synchronization function
- Inhibit for zero current consumption (100mA typ. at $V_{CC} = 24V$)
- Protection against feedback disconnection
- Thermal shutdown
- Output over voltage protection
- Soft start function

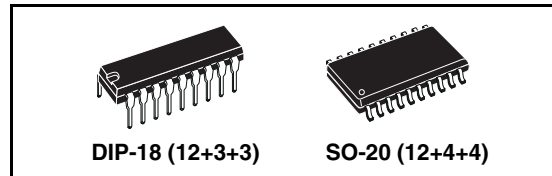

Description

The L4973 is a step down monolithic power switching regulator delivering 3.5A at fixed voltages of 3.3V or 5.1V and using a simple external divider output adjustable voltage up to 50V. Realized in BCD mixed technology, the device uses an internal power D-MOS transistor (with a typical $R_{DS(on)}$ of 0.15 Ω) to obtain very high efficiency and very fast switching times. Switching frequency up to 300kHz are achievable (the maximum power dissipation of the packages must be observed).

A wide input voltage range between 8V to 55V and output voltages regulated from 3.3V to 40V cover the majority of the today applications. Features of this new generation of DC-DC converter includes pulse by pulse current limit, hiccup mode for output short circuit protection, voltage feed forward regulation, soft start, input/output synchronization, protection against feedback loop disconnection, inhibit for zero current consumption and thermal shutdown. Packages available are in plastic dual in line, DIP-18 (12+3+3) for standard assembly, and SO20 (12+4+4) for SMD assembly.

Figure 1. Internal schematic diagram

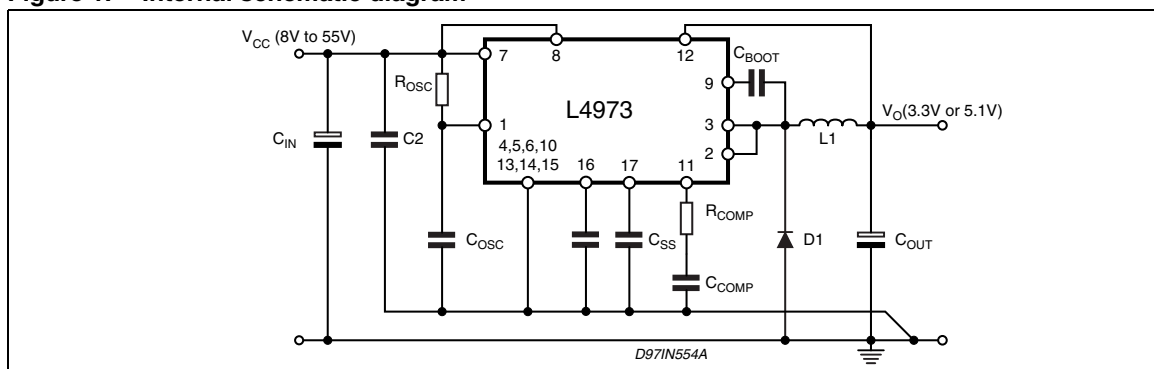

Contents

1	Block diagram	3
2	Pin settings	3
2.1	Pin connection	3
2.2	Pin description	4
3	Electrical data	5
3.1	Maximum ratings	5
3.2	Thermal data	5
4	Electrical characteristics	6
5	Evaluation board	9
6	Application circuit	11
7	Typical characteristics	12
8	Application ideas	20
9	Package mechanical data	22
10	Order code	25
11	Revision history	26

1 Block diagram

Figure 2. Block diagram

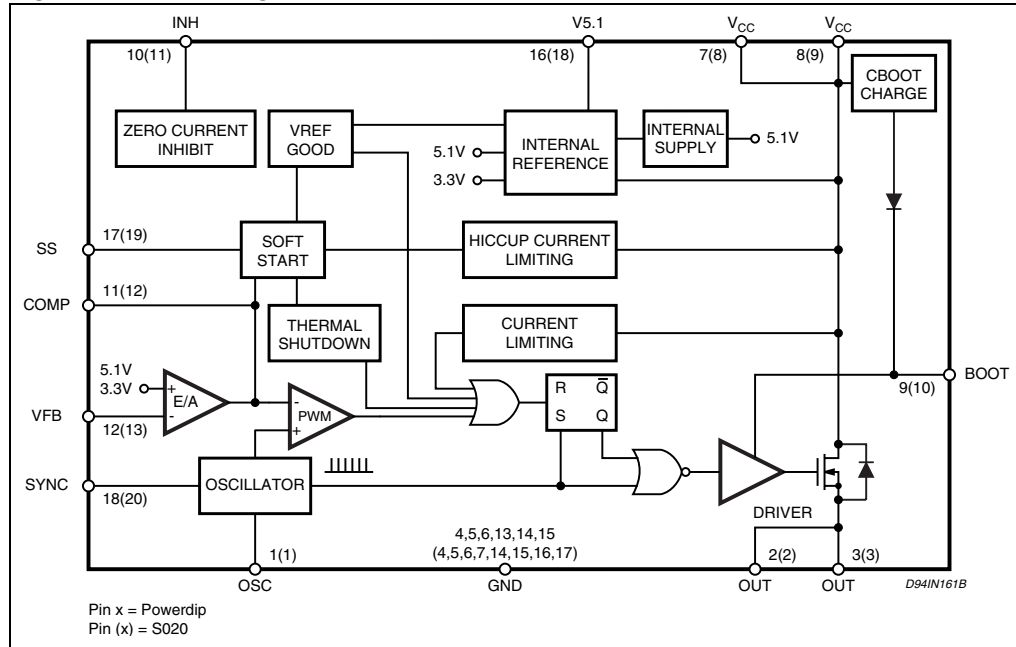

2 Pin settings

2.1 Pin connection

Figure 3. Pin connection (top view)

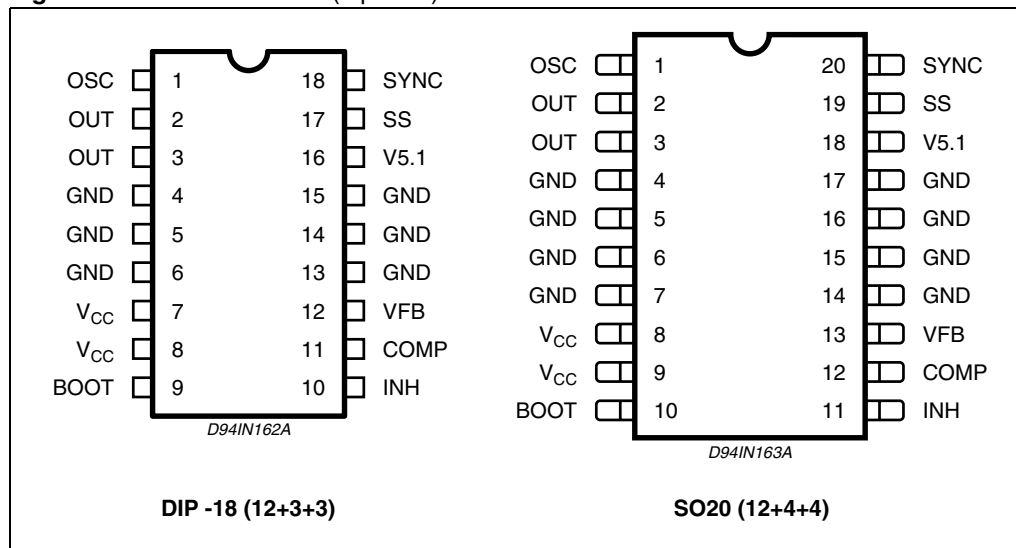

2.2 Pin description

Table 1. Pin description

N° Pin		Name	Description
DIP-18	SO-20		
11	12	COMP	E/A output to be used for frequency compensation
10	11	INH	A logic signal (active high) disables the device (sleep mode operation). If not used it must be connected to GND; if floating the device is disabled.
9	10	BOOT	A capacitor connected between this pin and the output allows to drive the internal D-MOS.
18	20	SYNC	Input/Output synchronization.
7,8	8,9	V _{CC}	Unregulated DC input voltage
2,3	2,3	OUT	Stepdown regulator output.
12	13	VFB	Stepdown feedback input. Connecting the output directly to this pin results in an output voltage of 3.3V for the L4973V3.3 and 5.1V for L4973V5.1. An external resistive divider is required for higher output voltages. For output voltage resistive divider is required for higher output voltages. For output voltage less than 3.3V, see Note: 1 and Figure 33 .
16	18	V5.1	Reference voltage externally available.
4,5,6 13,14,15	4,5,6,7 14,15,16,17	GND	Signal ground
1	1	OSC	An external resistor connected between the unregulated input voltage and Pin 1 and a capacitor connected from Pin 1 to ground fixes the switching frequency. (Line feed forward is automatically obtained)

Note: 1 The maximum power dissipation of the package must be observed.

3 Electrical data

3.1 Maximum ratings

Table 2. Absolute maximum ratings

Symbol		Parameter	Value	Unit
DIP-18	SO-20			
V ₇ , V ₈	V ₉ , V ₈	Input voltage	58	V
V ₂ , V ₃	V ₂ , V ₃	Output DC voltage Output peak voltage at t = 0.1 μs f = 200KHz	-1 - 5	V V
I ₂ , I ₃	I ₂ , I ₃	Maximum output current	int. limit.	
V ₉ -V ₈	V ₁₀ -V ₈		14	V
V ₉	V ₁₀	Bootstrap voltage	70	V
V ₁₁	V ₁₂	Analogs input voltage (V _{CC} = 24V)	12	V
V ₁₇	V ₁₉	Analogs input voltage (V _{CC} = 24V)	13	V
V ₁₂	V ₁₃	(V _{CC} = 20V)	6 -0.3	V V
V ₁₈	V ₂₀	(V _{CC} = 20V)	5.5 0.3	V V
V ₁₀	V ₁₁	Inhibit	V _{CC} -0.3	V V
P _{tot}		DIP 12+3+3 Power dissipation a T _{pins} ≤ 90°C (T _A = 70°C no copper area) (T _A = 70°C 4cm copper area on PCB)	5 1.3 2	W W W
		SO-20 Power dissipation a T _{pins} = 90°C	4	W
T _J , T _{STG}		Junction and storage temperature	-40 to 150	°C

3.2 Thermal data

Table 3. Thermal data

Symbol	Parameter	DIP-18	SO-20	Unit
R _{thJP}	Maximum thermal resistance junction-pin	12	15	°C/W
R _{thJA}	Maximum thermal resistance junction-ambient	60 ⁽¹⁾	80 ⁽¹⁾	°C/W

1. Package mounted on board

4 Electrical characteristics

Table 4. Electrical characteristics

 (Refer to the test circuit, $V_{CC} = 24V$; $T_J = 25^\circ C$, $C_{OSC} = 2.7nF$; $R_{OSC} = 20K\Omega$; unless otherwise specified)

Symbol	Parameter	Test condition	Min	Typ	Max	Unit	
Dynamic characteristics							
	Input Voltage Range ⁽¹⁾	$V_O = V_{REF}$ to 40V; $I_O = 3.5A$	(2)	8		55	V
	Output Voltage L4973V5.1	$I_O = 1A$		5.05	5.1	5.15	V
		$I_O = 0.5A$ to 3.5A $V_{CC} = 8V$ to 55V		5.00	5.1	5.20	V
			(2)	4.95	5.1	5.25	V
	Output Voltage L4973V3.3	$I_O = 1A$		3.326	3.36	3.393	V
		$I_O = 0.5A$ to 3.5A $V_{CC} = 8V$ to 40V		3.292	3.36	3.427	V
			(2)	3.26	3.36	3.46	V
	$R_{DS(on)}$	$V_{CC} = 10.5V$ $I_O = 3.5A$			0.15	0.22	Ω
			(2)				0.35
	Maximum Limiting Current	$V_{CC} = 8V$ to 55V	(2)	3.8	4.5	5.5	A
				4	4.5	5.5	A
η	Efficiency	$V_O = 5.1V$; $I_O = 3.5A$			90		%
		$V_O = 3.3V$; $I_O = 3.5A$			85		%
	Switching Frequency		(2)	90	100	110	KHz
	Supply Voltage Ripple Rejection	$V_i = V_{CC} + 2V_{RMS}$ $V_O = V_{ref}$; $I_O = 1A$; $f_{ripple} = 100Hz$		60			dB
Δf_{sw}	Switching Frequency Stability vs., Supply Voltage	$V_{CC} = 8V$ to 55V			2	5	%
Reference section							
	Reference Voltage	$I_{ref} = 0$ to 20mA; $V_{CC} = 8$ to 55V		5.025	5.1	5.175	V
			(2)	4.950	5.1	5.250	V
	Line Regulation	$I_{ref} = 0mA$; $V_{CC} = 8$ to 55V			5	10	mV
	Load Regulation	$V_{ref} = 0$ to 5mA; $V_{CC} = 0$ to 20mA			2 6	10 25	mV mV
	Short Circuit Current			30	65	100	mA

Table 4. Electrical characteristics (continued)(Refer to the test circuit, $V_{CC} = 24V$; $T_J = 25^\circ C$, $C_{OSC} = 2.7nF$; $R_{OSC} = 20K\Omega$; unless otherwise specified)

Symbol	Parameter	Test condition	Min	Typ	Max	Unit	
Soft start							
	Soft Start Charge Current		30	45	60	μA	
	Soft Start Discharge Current		15	22	30	μA	
Inhibit							
	High Level Voltage		(2)	3.0		V	
	Low Level Voltage		(2)		0.8	V	
	I_{source} High Level	$V_{INH} = 3V$	(2)	10	16	50	μA
	I_{source} Low Level	$V_{INH} = 0.8V$	(2)	10	15	50	μA
DC characteristics							
	Total Operating Quiescent Current	Duty Cycle = 50%		4	6	mA	
	Quiescent Current	Duty Cycle = 0		2.7	4	mA	
	Total stand-by quiescent current	$V_{CC} = 24V$; $V_{INH} = 5V$		100	200	μA	
		$V_{CC} = 55V$; $V_{INH} = 5V$		150	300	μA	
Error amplifier							
	High Level Output Voltage		11.0			V	
	Low Level Output Voltage				0.65	V	
	Source Bias Current		1	2	3	μA	
	Source Output Current		200	300	600	μA	
	Sink Output Current		200	300		μA	
	Supply Voltage Ripple Rejection	$V_{COMP} = V_{FB}$ $C_{REF} = 4.7\mu F$ 1-5mA load current	60	80		dB	
	DC Open Loop Gain	$R_L = \infty$	50	60		dB	
	Transconductance	$I_{comp} = -0.1$ to $0.1mA$; $V_{comp} = 6V$		2.5		mS	
Oscillator section							
	Ramp valley		0.78	0.85	0.92	V	

Table 4. Electrical characteristics (continued)

(Refer to the test circuit, $V_{CC} = 24V$; $T_J = 25^\circ C$, $C_{OSC} = 2.7nF$; $R_{OSC} = 20K\Omega$; unless otherwise specified)

Symbol	Parameter	Test condition	Min	Typ	Max	Unit
	Ramp peak	$V_{CC} = 8V$	1.9	2.1	2.3	V
		$V_{CC} = 55V$	9	9.6	10.2	V
	Maximum Duty Cycle		95	97		%
	Maximum Frequency	Duty Cycle = 0%; $R_{OSC} = 13K\Omega$; $C_{OSC} = 820pF$;			300	KHz
Sync function						
	High Input Voltage	$V_{CC} = 8V$ to $55V$	3.5			V
	Low Input Voltage	$V_{CC} = 8V$ to $55V$			0.9	V
	Slave Sink Current		0.15	0.25	0.45	mA
	Master Output Amplitude	$I_{source} = 3mA$	4	4.5		V
	Output Pulse Width	no load, $V_{sync} = 4.5V$	0.20	0.35		μs

1. Pulse testing with a low duty cycle
2. Specifications referred to T_J from $-40^\circ C$ to $125^\circ C$.

5 Evaluation board

Figure 4. Evaluation board circuit

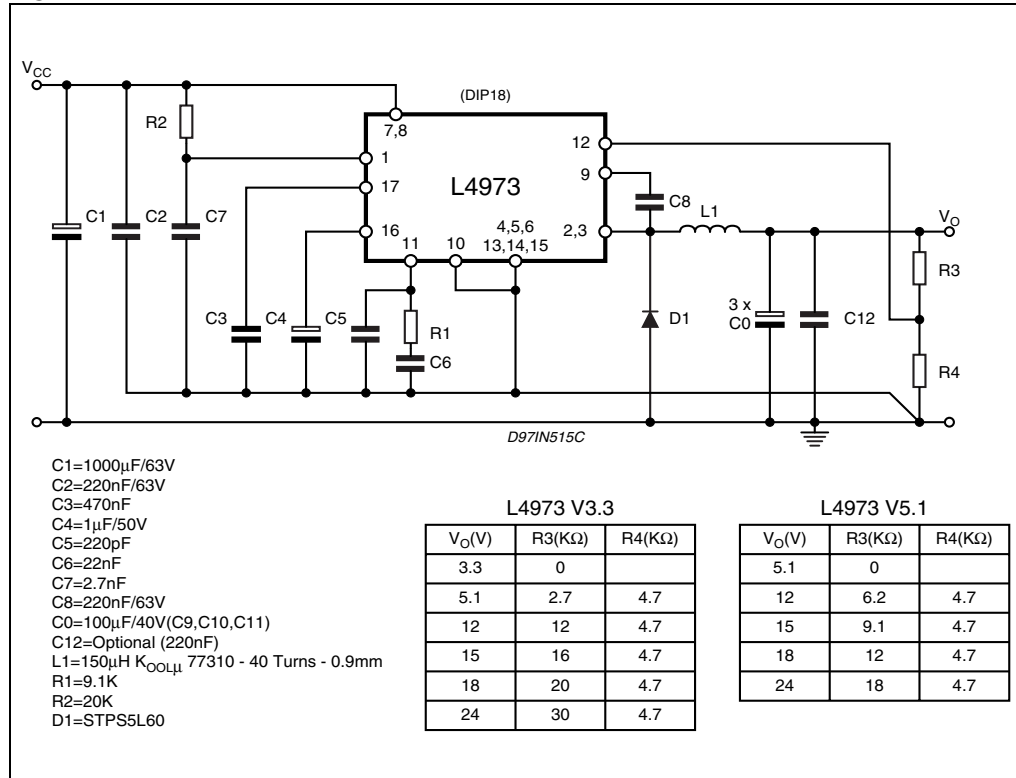

Table 5. Typical performance (using evaluation board) $f_{SW} = 100\text{kHz}$

Output voltage	Output ripple	Efficiency	Line regulator $I_o = 3.5\text{A}$ $V_{CC} = 8$ to 50V	Load regulator $V_{CC} = 35\text{V}$ $I_o = 1$ to 3.5A
3.3V	20mV	81.5 (%)	3mV	6mV
5.1V	20mV	86.7 (%)	3mV	6mV
12V	30mV	93.5 (%)	3mV ($V_{CC} = 15$ to 50V)	4mV

Figure 5. Evaluation board (components side)

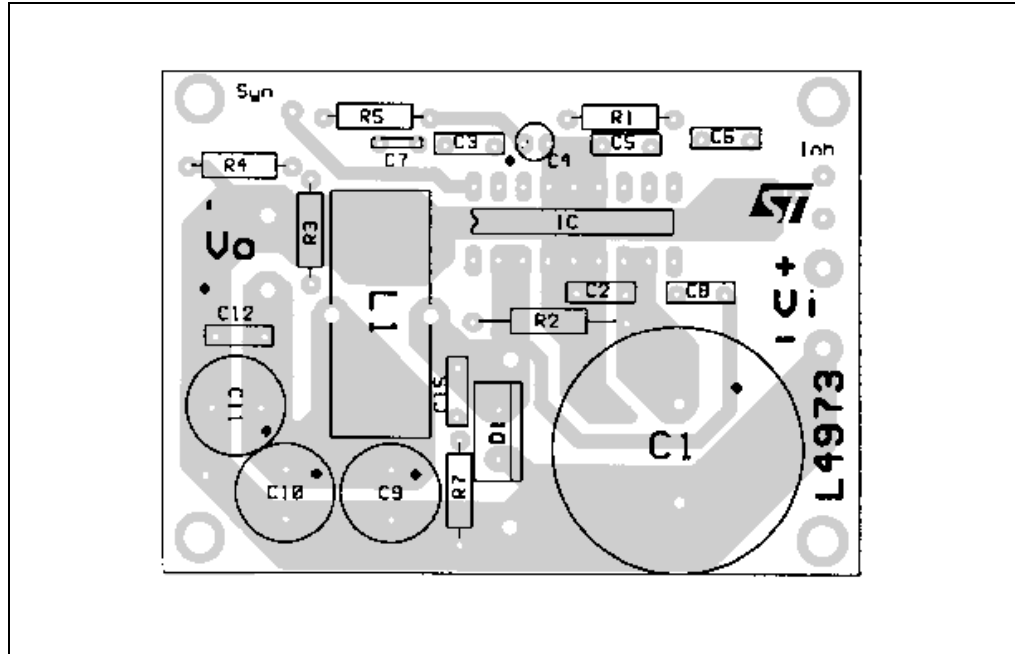
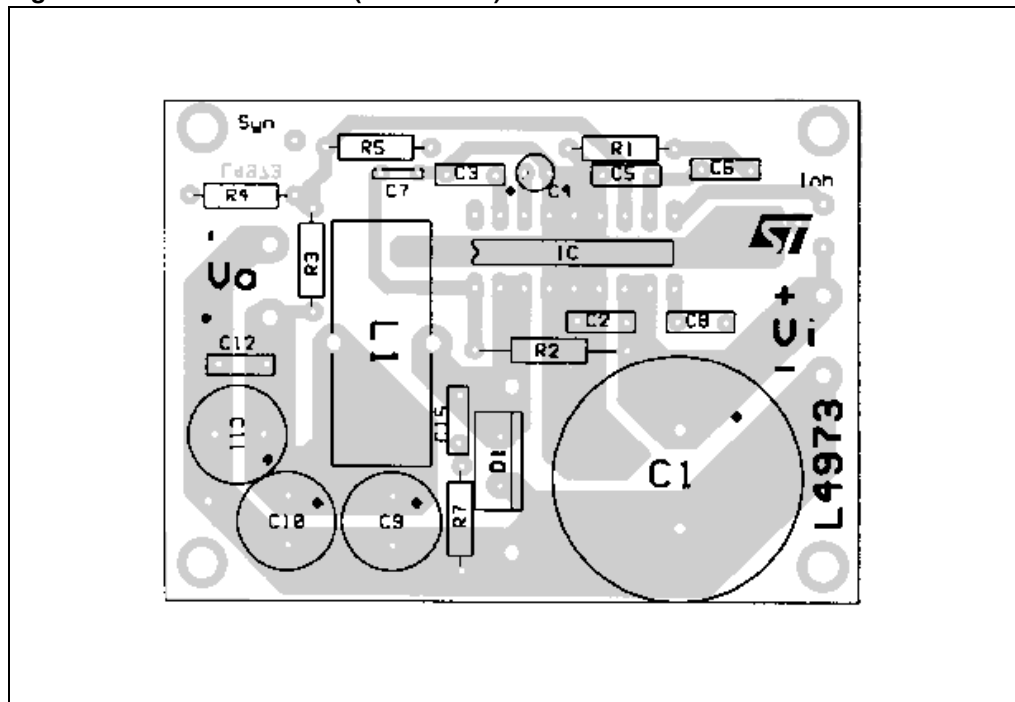

Figure 6. Evaluation board (solder side)



6 Application circuit

Figure 7. Application circuit (see [Figure 4](#) part list)

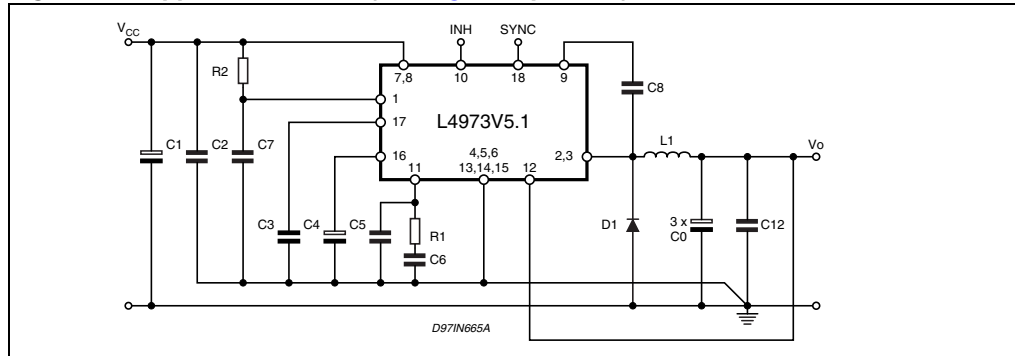
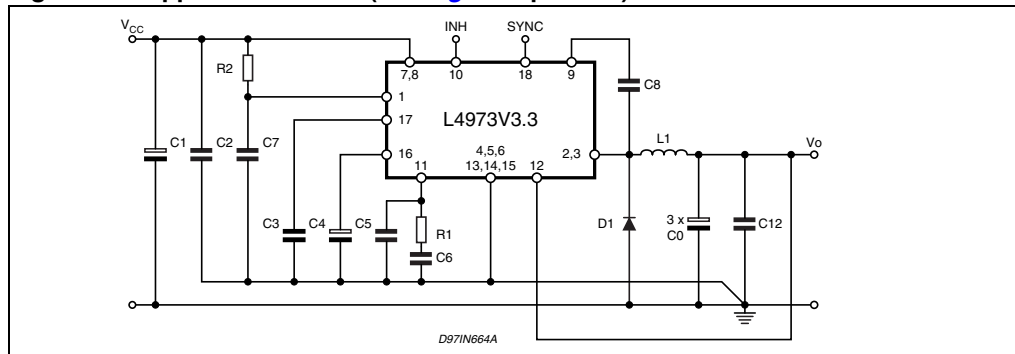

Figure 8. Application circuit (see [Figure 4](#) part list)



7 Typical characteristics

Figure 9. Quiescent drain current vs. input voltage (0% duty cycle)

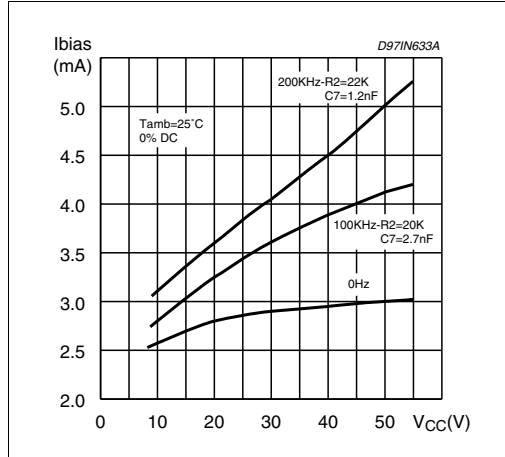

Figure 10. Quiescent drain current vs. junction temperature

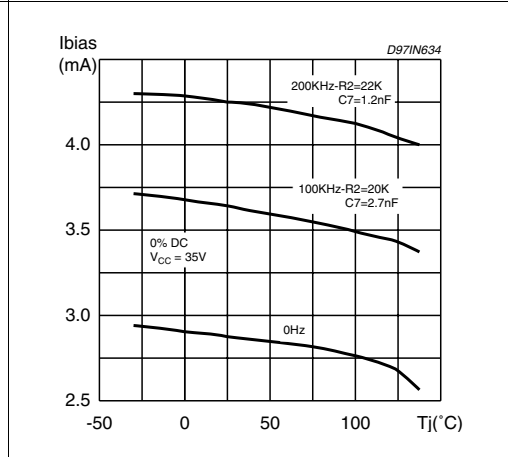

Figure 11. Stand by drain current vs. input voltage

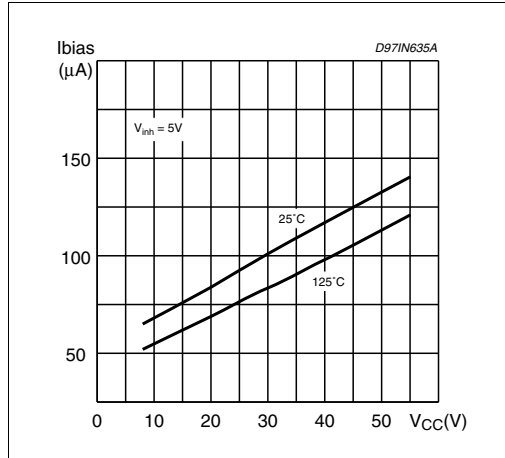

Figure 12. Reference voltage vs. junction temperature (pin 16)

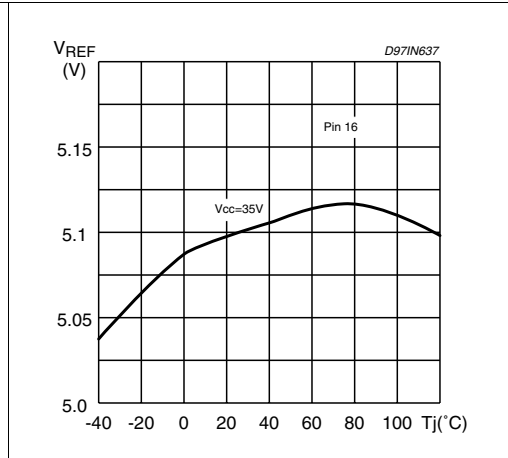

Figure 13. Reference voltage vs. input voltage (pin 16)

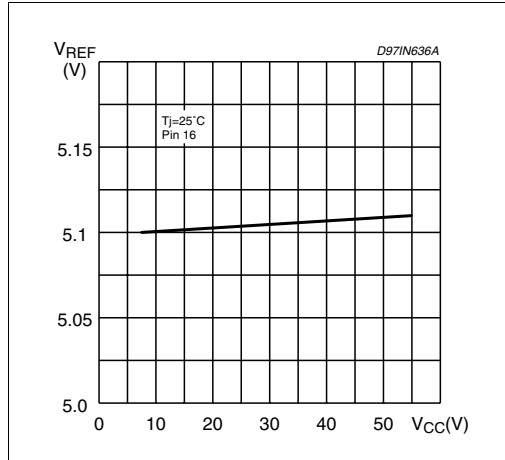

Figure 14. Reference voltage vs. reference input current

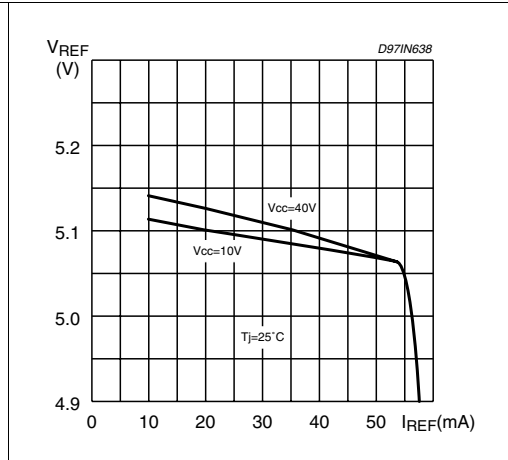

Figure 15. Inhibit current vs. inhibit voltage (pin 10)

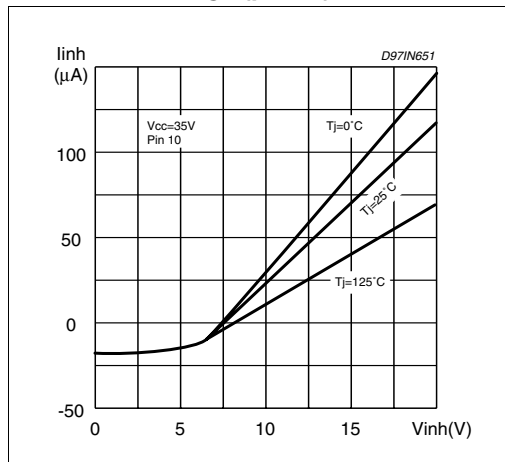

Figure 16. Line regulation (see Figure 7)

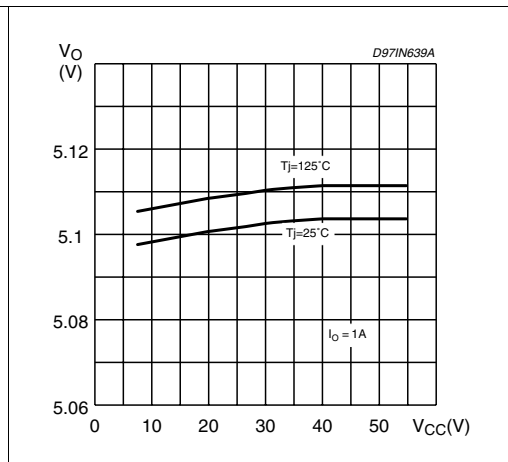

Figure 17. Load regulation (see Figure 7) Figure 18. Line regulation (see Figure 8)

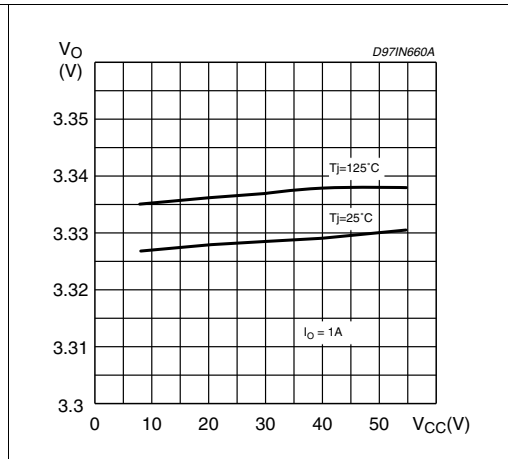
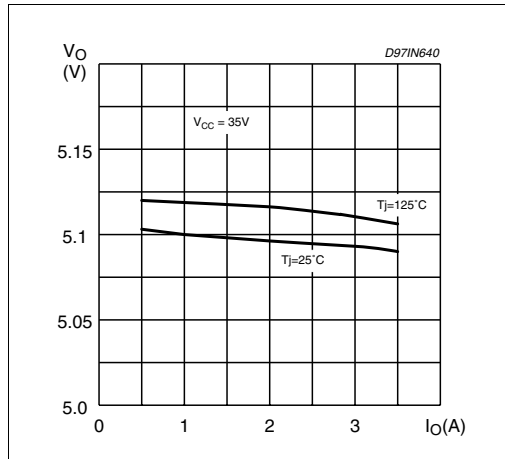

Figure 19. Load regulation (see [Figure 4](#)) Figure 20. Switching frequency vs. R2 and C7 ([Figure 4](#))

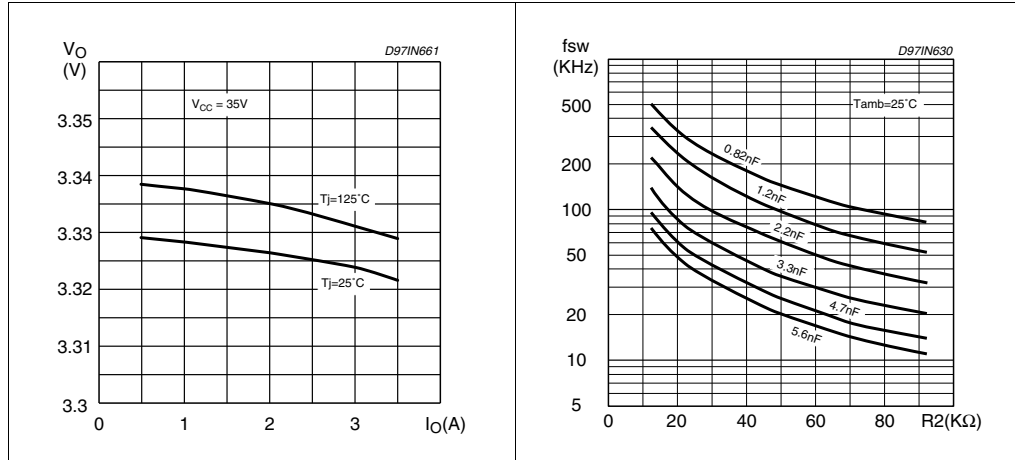

Figure 21. Switching frequency vs. input voltage

Figure 22. Switching frequency vs. junction temperature (see [Figure 4](#))

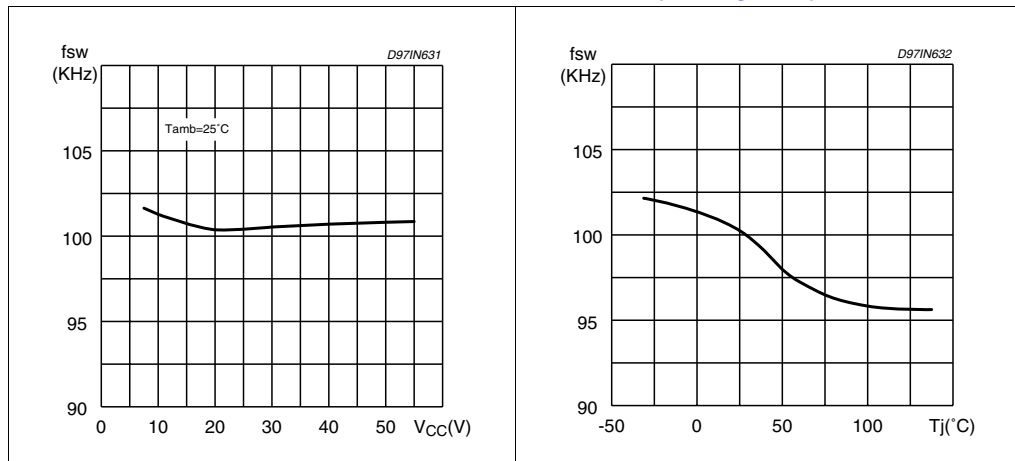

Figure 23. Dropout voltage between pin 7,8 and 2,3

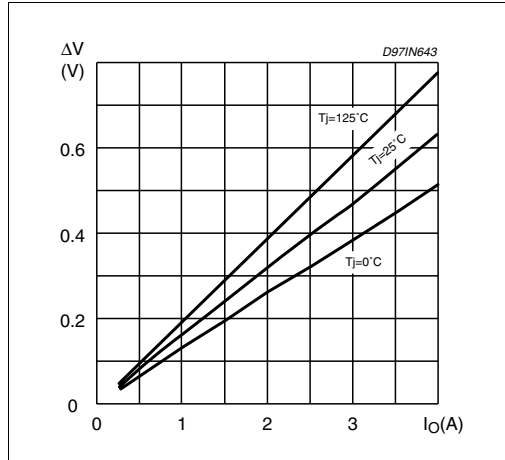

Figure 24. Efficiency vs. output voltage (see Figure 6)

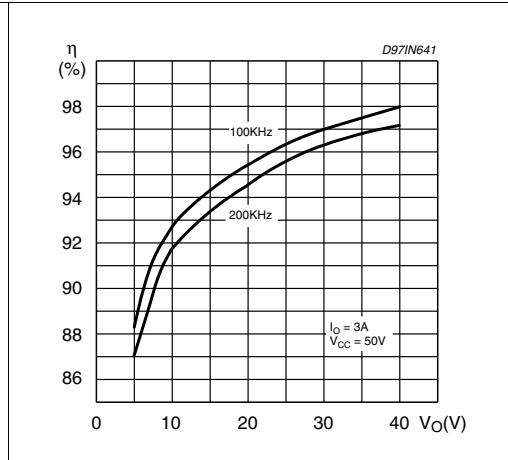

Figure 25. Dropout voltage between pin 7,8 and 2,3

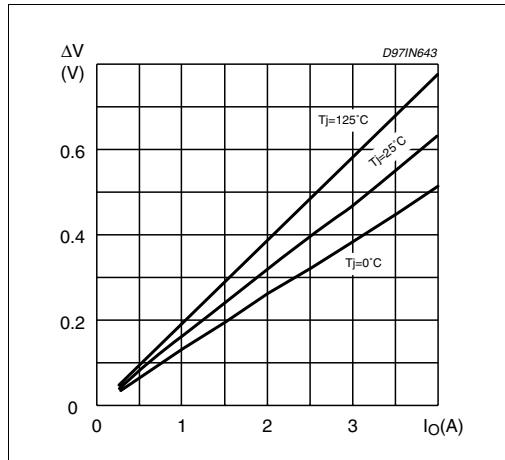

Figure 26. Efficiency vs. output voltage (see Figure 4)

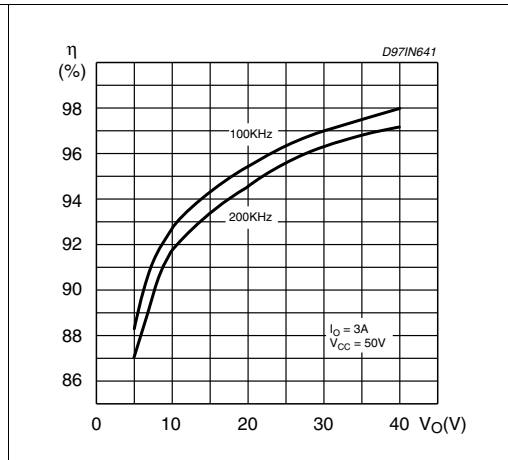

Figure 27. Efficiency vs. output voltage (Diode STPS745D)

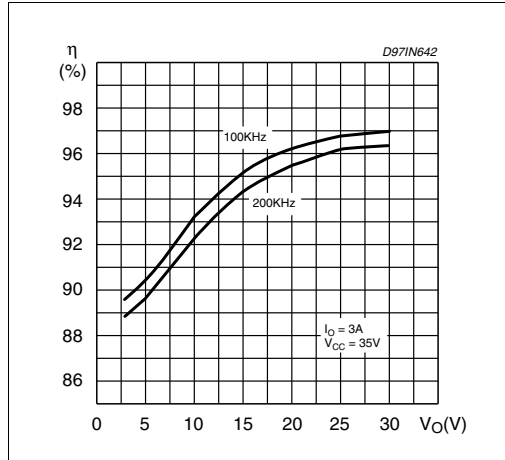

Figure 28. Efficiency vs. output current (see Figure 7)

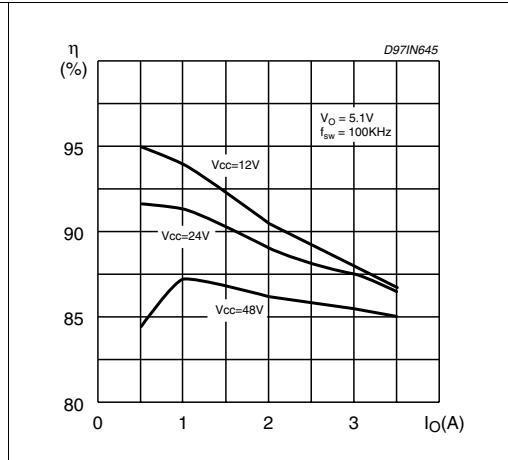

Figure 29. Efficiency vs. output current (see Figure 7)

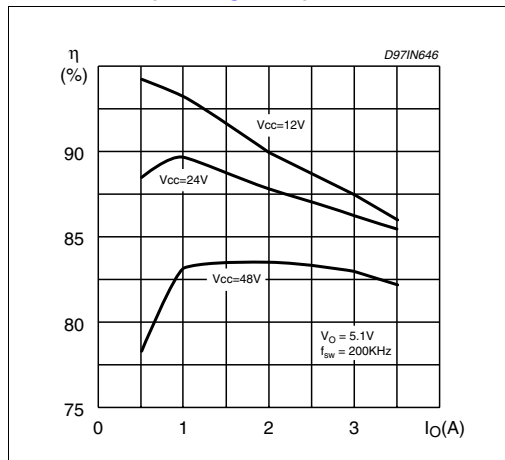

Figure 30. Efficiency vs. output current (see Figure 8)

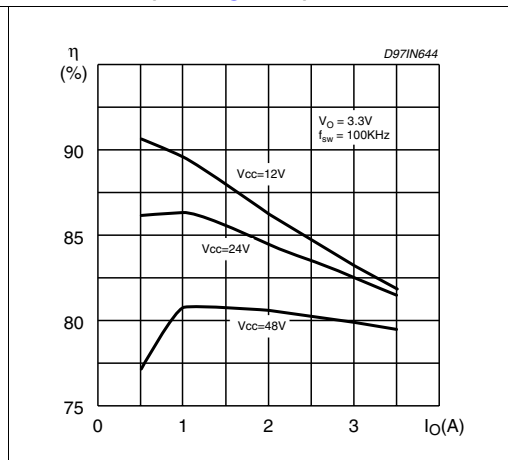

Figure 31. Efficiency vs. output current (see Figure 8)

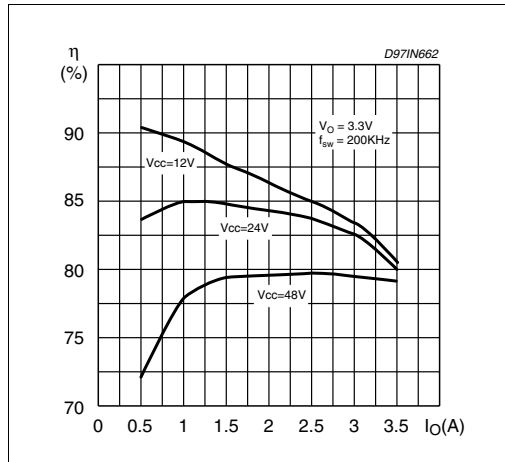

Figure 32. Power dissipation vs. input voltage (device only) (see Figure 7)

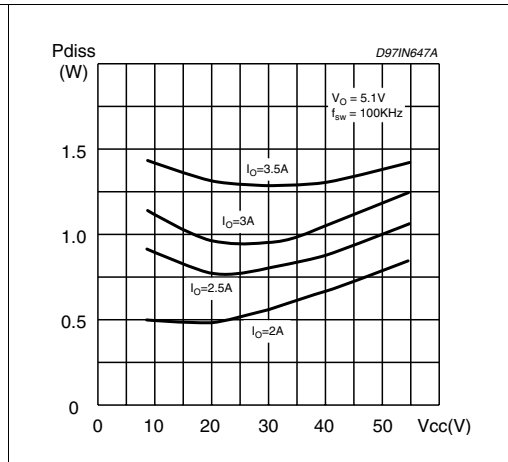

Figure 33. Power dissipation vs. output voltage (device only)

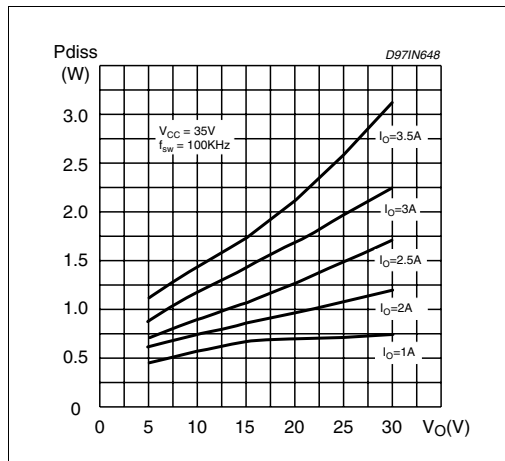

Figure 34. Pulse by pulse limiting current vs. junction temperature

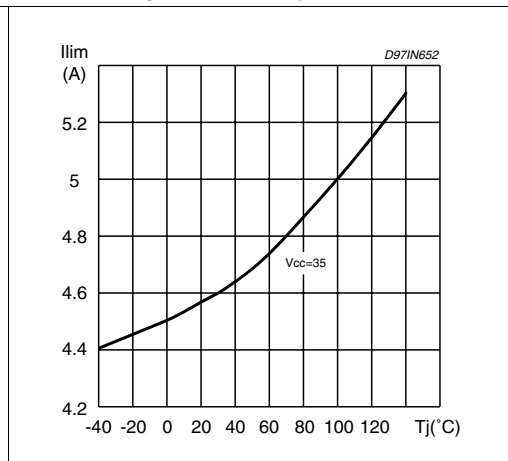

Figure 35. Load transient

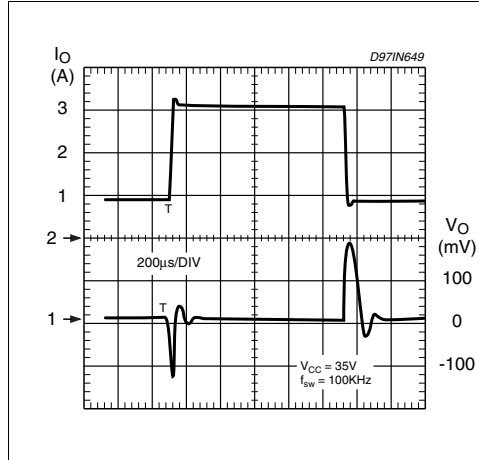

Figure 36. Line transient

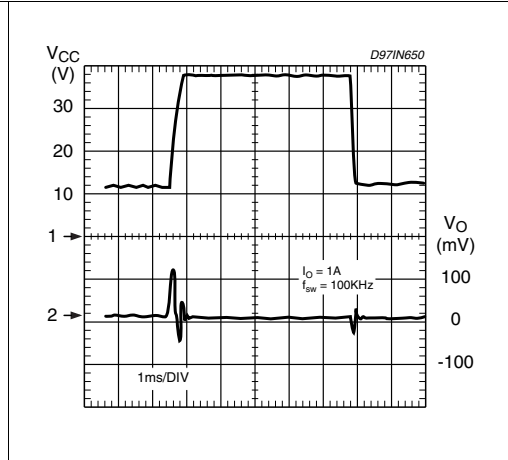

Figure 37. Source current rise and fall time, pin 2, 3 (see Figure 4)

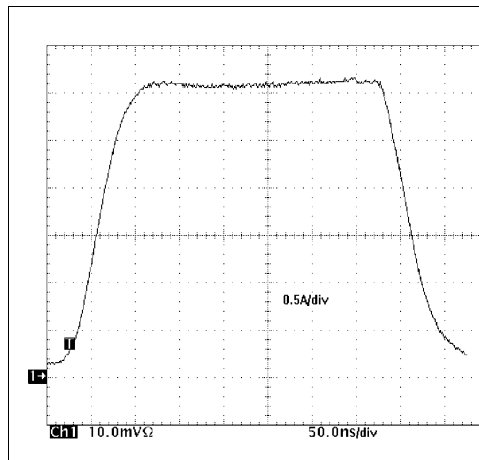

Figure 38. Soft start capacitor selection vs. inductor and V_{CC} max (ref. AN938)

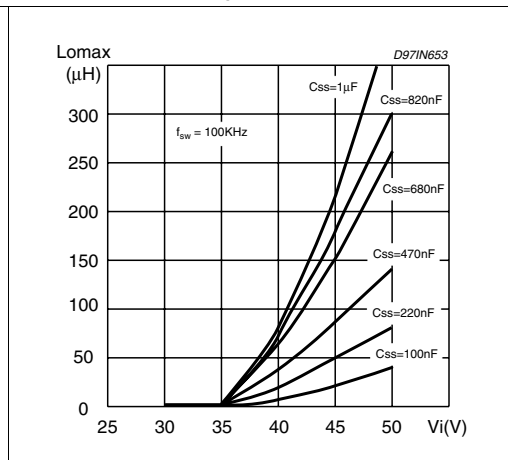
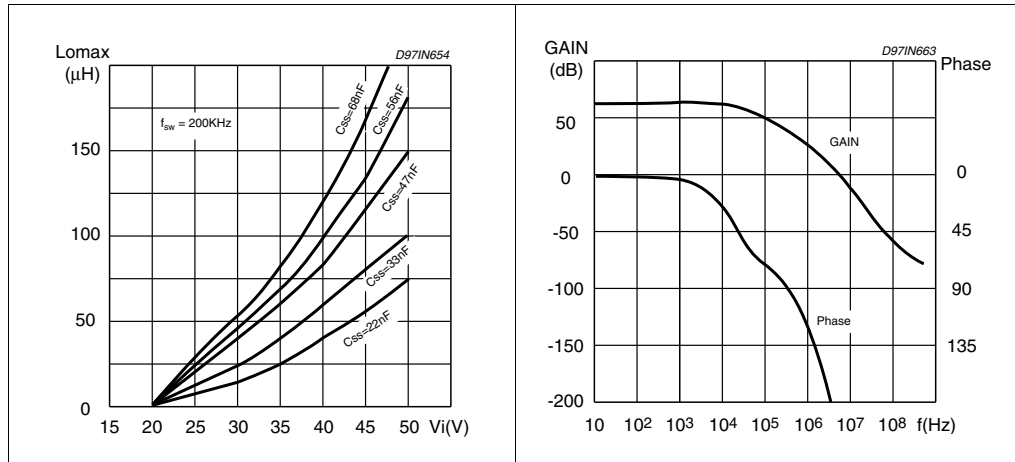

Figure 39. Soft start capacitor selection vs. inductor and V_{CC} max (ref. AN938)

Figure 40. Open loop frequency and phase of error amplifier



8 Application ideas

Figure 41. 3.5A at $V_O < 3.3V$ (see part list [Figure 4](#))

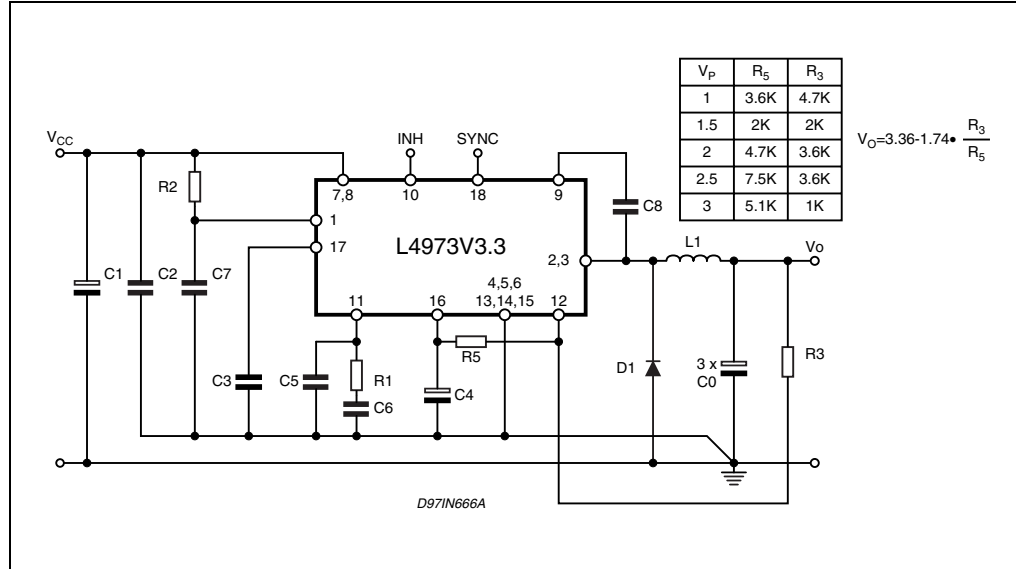

Figure 42. 12V to 3.3V high performance buck converter (fsw = 200kHz)

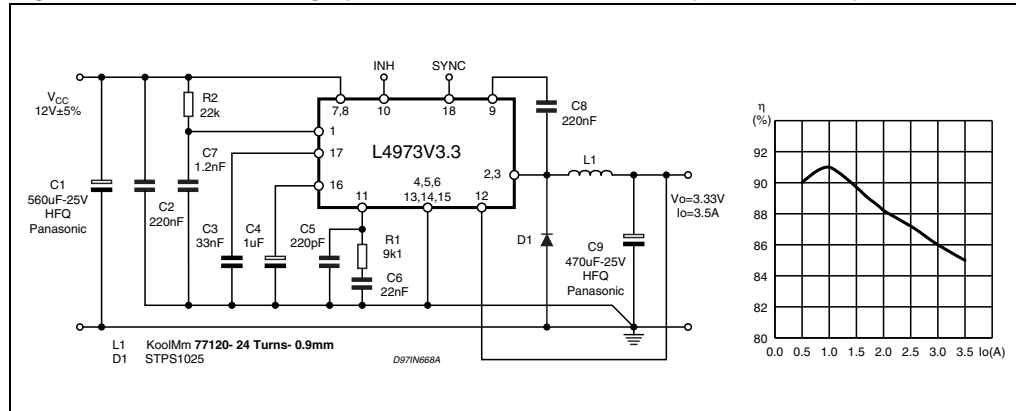

Figure 43. Synchronization example

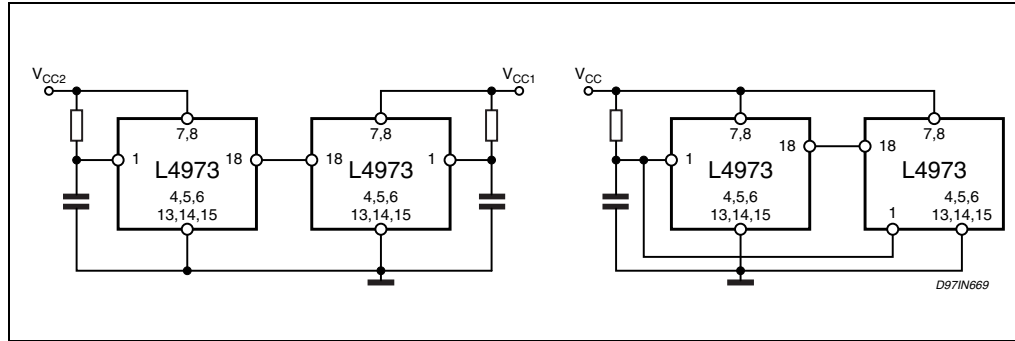
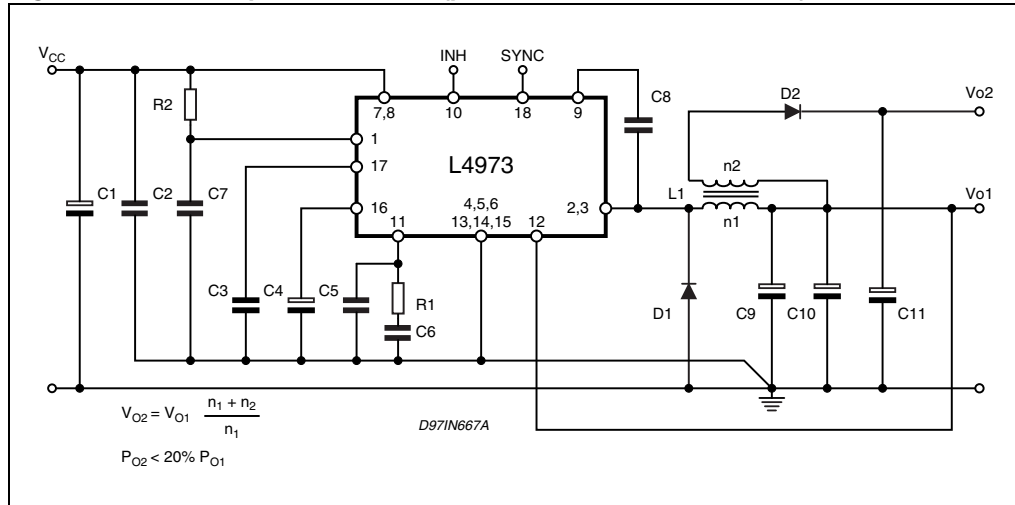

Figure 44. Multi output not isolated (pin out referred to DIP12+3+3)



9 Package mechanical data

In order to meet environmental requirements, ST offers these devices in ECOPACK® packages. These packages have a Lead-free second level interconnect. The category of second level interconnect is marked on the package and on the inner box label, in compliance with JEDEC Standard JESD97. The maximum ratings related to soldering conditions are also marked on the inner box label. ECOPACK is an ST trademark. ECOPACK specifications are available at: www.st.com

Table 6. DIP-18 mechanical data

Dim.	mm.			inch		
	Min	Typ	Max	Min	Typ	Max
a1	0.51			0.020		
B	0.85		1.40	0.033		0.055
b		0.50			0.020	
b1	0.38		0.50	0.015		0.020
D			24.80			0.976
E		8.80			0.346	
e		2.54			0.100	
e3		20.32			0.800	
F			7.10			0.280
I			5.10			0.201
L		3.30			0.130	
Z			2.54			0.100

Figure 45. Package dimensions

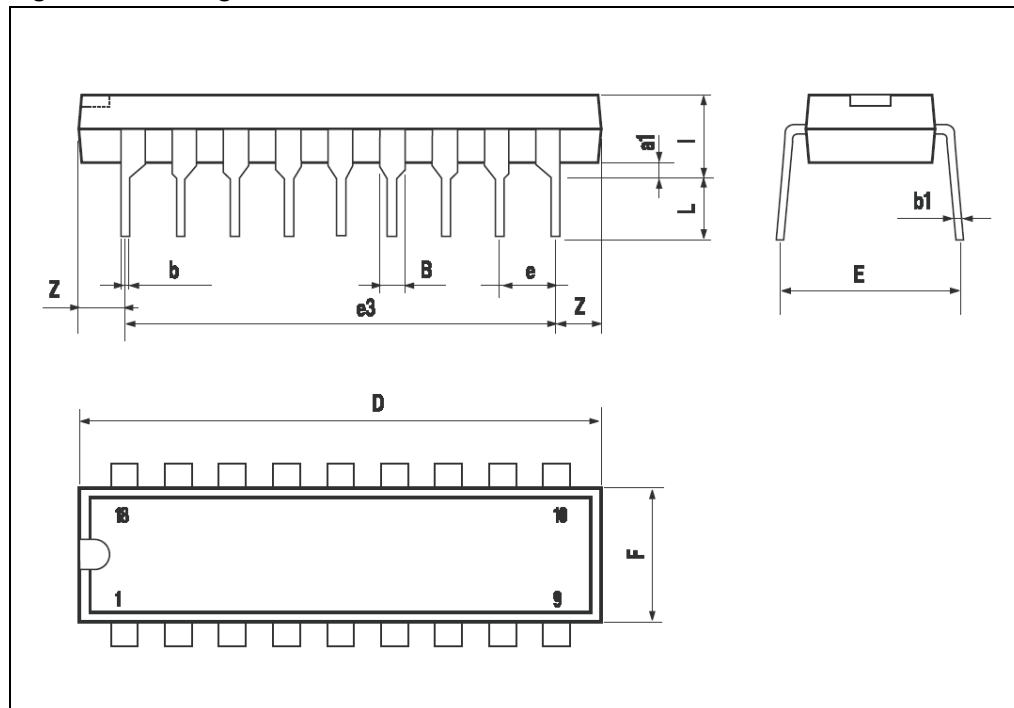
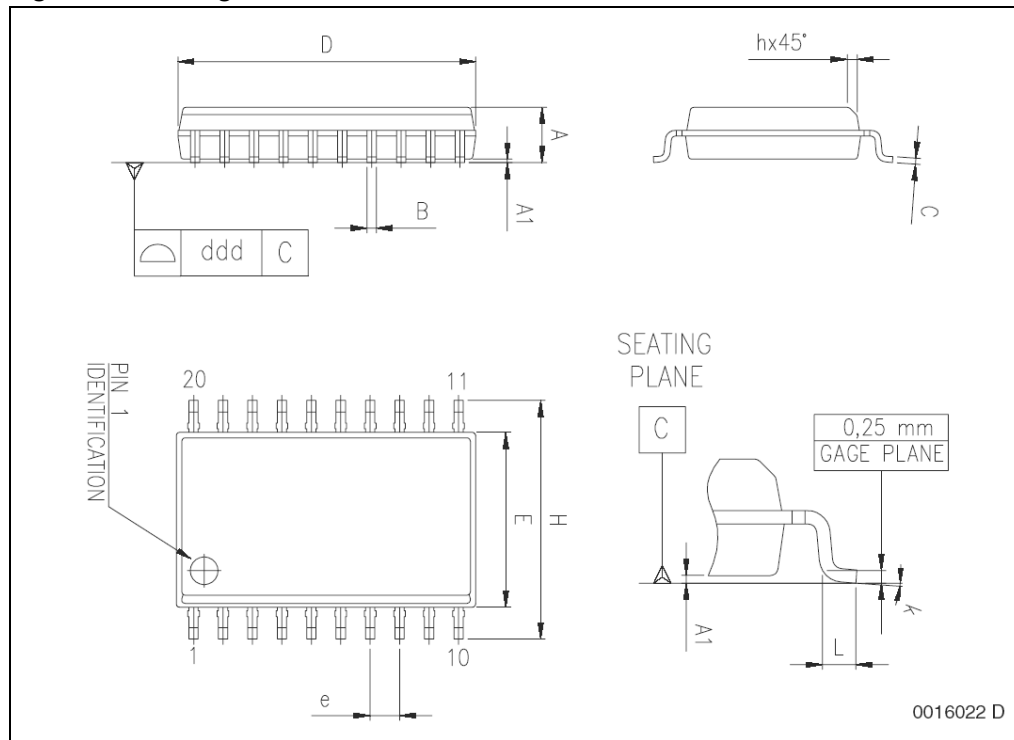

Table 7. SO-20 mechanical data

Dim.	mm.			inch		
	Min	Typ	Max	Min	Typ	Max
A	2.35		2.65	0.093		0.104
A1	0.10		0.30	0.004		0.012
B	0.33		0.51	0.013		0.200
C	0.23		0.32	0.009		0.013
D ⁽¹⁾	12.60		13.00	0.496		0.512
E	7.40		7.60	0.291		0.299
e		1.27			0.050	
H	10.0		10.65	0.394		0.419
h	0.25		0.75	0.010		0.030
L	0.40		1.27	0.016		0.050
k	0° (min.), 8° (max.)					
ddd			0.10			0.004

Figure 46. Package dimensions



10 Order code

Table 8. Order code

Part number	Package	Packaging
L4973D3.3, E-L4973D3.3	SO-20	Tube
L4973D3.3-013TR, E-L4973D3.3-TR	SO-20	Tape and reel
L4973D5.1	SO-20	Tube
L4973D5.1-013TR	SO-20	Tape and reel
L4973V3.3, E-L4973V3.3	DIP-18	Tube
L4973V5.1, E-L4973V5.1	DIP-18	Tube

11 Revision history

Table 9. Revision history

Date	Revision	Changes
12-Sep-2001	13	First Issue
07-May-2005	14	Updated the Layout look & feel. Changed name of the D1 on the fig. 5.
14-Dec-2005	15	Added the ECOPACK part numbers in the Table 1. Order Codes.
06-Dec-2006	16	The document has been reformatted, and order codes updated
07-May-2007	17	New data on Table 4

Please Read Carefully:

Information in this document is provided solely in connection with ST products. STMicroelectronics NV and its subsidiaries ("ST") reserve the right to make changes, corrections, modifications or improvements, to this document, and the products and services described herein at any time, without notice.

All ST products are sold pursuant to ST's terms and conditions of sale.

Purchasers are solely responsible for the choice, selection and use of the ST products and services described herein, and ST assumes no liability whatsoever relating to the choice, selection or use of the ST products and services described herein.

No license, express or implied, by estoppel or otherwise, to any intellectual property rights is granted under this document. If any part of this document refers to any third party products or services it shall not be deemed a license grant by ST for the use of such third party products or services, or any intellectual property contained therein or considered as a warranty covering the use in any manner whatsoever of such third party products or services or any intellectual property contained therein.

UNLESS OTHERWISE SET FORTH IN ST'S TERMS AND CONDITIONS OF SALE ST DISCLAIMS ANY EXPRESS OR IMPLIED WARRANTY WITH RESPECT TO THE USE AND/OR SALE OF ST PRODUCTS INCLUDING WITHOUT LIMITATION IMPLIED WARRANTIES OF MERCHANTABILITY, FITNESS FOR A PARTICULAR PURPOSE (AND THEIR EQUIVALENTS UNDER THE LAWS OF ANY JURISDICTION), OR INFRINGEMENT OF ANY PATENT, COPYRIGHT OR OTHER INTELLECTUAL PROPERTY RIGHT.

UNLESS EXPRESSLY APPROVED IN WRITING BY AN AUTHORIZED ST REPRESENTATIVE, ST PRODUCTS ARE NOT RECOMMENDED, AUTHORIZED OR WARRANTED FOR USE IN MILITARY, AIR CRAFT, SPACE, LIFE SAVING, OR LIFE SUSTAINING APPLICATIONS, NOR IN PRODUCTS OR SYSTEMS WHERE FAILURE OR MALFUNCTION MAY RESULT IN PERSONAL INJURY, DEATH, OR SEVERE PROPERTY OR ENVIRONMENTAL DAMAGE. ST PRODUCTS WHICH ARE NOT SPECIFIED AS "AUTOMOTIVE GRADE" MAY ONLY BE USED IN AUTOMOTIVE APPLICATIONS AT USER'S OWN RISK.

Resale of ST products with provisions different from the statements and/or technical features set forth in this document shall immediately void any warranty granted by ST for the ST product or service described herein and shall not create or extend in any manner whatsoever, any liability of ST.

ST and the ST logo are trademarks or registered trademarks of ST in various countries.

Information in this document supersedes and replaces all information previously supplied.

The ST logo is a registered trademark of STMicroelectronics. All other names are the property of their respective owners.

© 2007 STMicroelectronics - All rights reserved

STMicroelectronics group of companies

Australia - Belgium - Brazil - Canada - China - Czech Republic - Finland - France - Germany - Hong Kong - India - Israel - Italy - Japan - Malaysia - Malta - Morocco - Singapore - Spain - Sweden - Switzerland - United Kingdom - United States of America

www.st.com

