

March 1997

Features

- Fully Static Operation
- Industry Standard 1024 x 4 Pinout (Same as Pinouts for 6514, 2114, 9114, and 4045 Types)
- Common Data Input and Output
- Memory Retention for Standby Battery Voltage as Low as 2V Min
- All Inputs and Outputs Directly TTL Compatible
- Three-State Outputs
- Low Standby and Operating Power

Description

The MWS5114 is a 1024 word by 4-bit static random access memory that uses the ion-implanted silicon gate complementary MOS (CMOS) technology. It is designed for use in memory systems where low power and simplicity in use are desirable. This type has common data input and data output and utilizes a single power supply of 4.5V to 6.5V.

The MWS5114 is supplied in 18 lead, hermetic, dual-in-line sidebraced ceramic packages (D suffix) and in 18 lead dual-in-line plastic packages (E suffix).

Ordering Information

200ns	250ns	300ns	TEMPERATURE RANGE	PACKAGE	PKG. NO.
MWS5114E3	MWS5114E2 MWS5114E2X	MWS5114E1	0°C to +70°C	PDIP Burn-In	E18.3 E18.3
MWS5114D3 MWS5114D3X	MWS5114D2	MWS5114D1	0°C to +70°C	SBDIP Burn-In	D18.3 D18.3

Pinout

**MWS5114
(PDIP, SBDIP)
TOP VIEW**

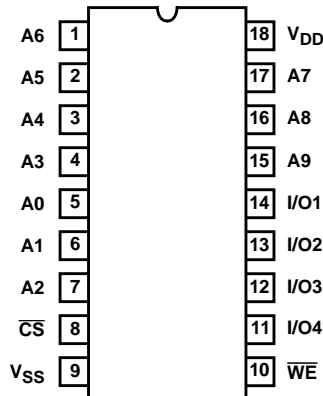

OPERATIONAL MODES

FUNCTION	CS	WE	DATA PINS
Read	0	1	Output: Dependent on data
Write	0	0	Input
Not Selected	1	X	High Impedance

Functional Block Diagram

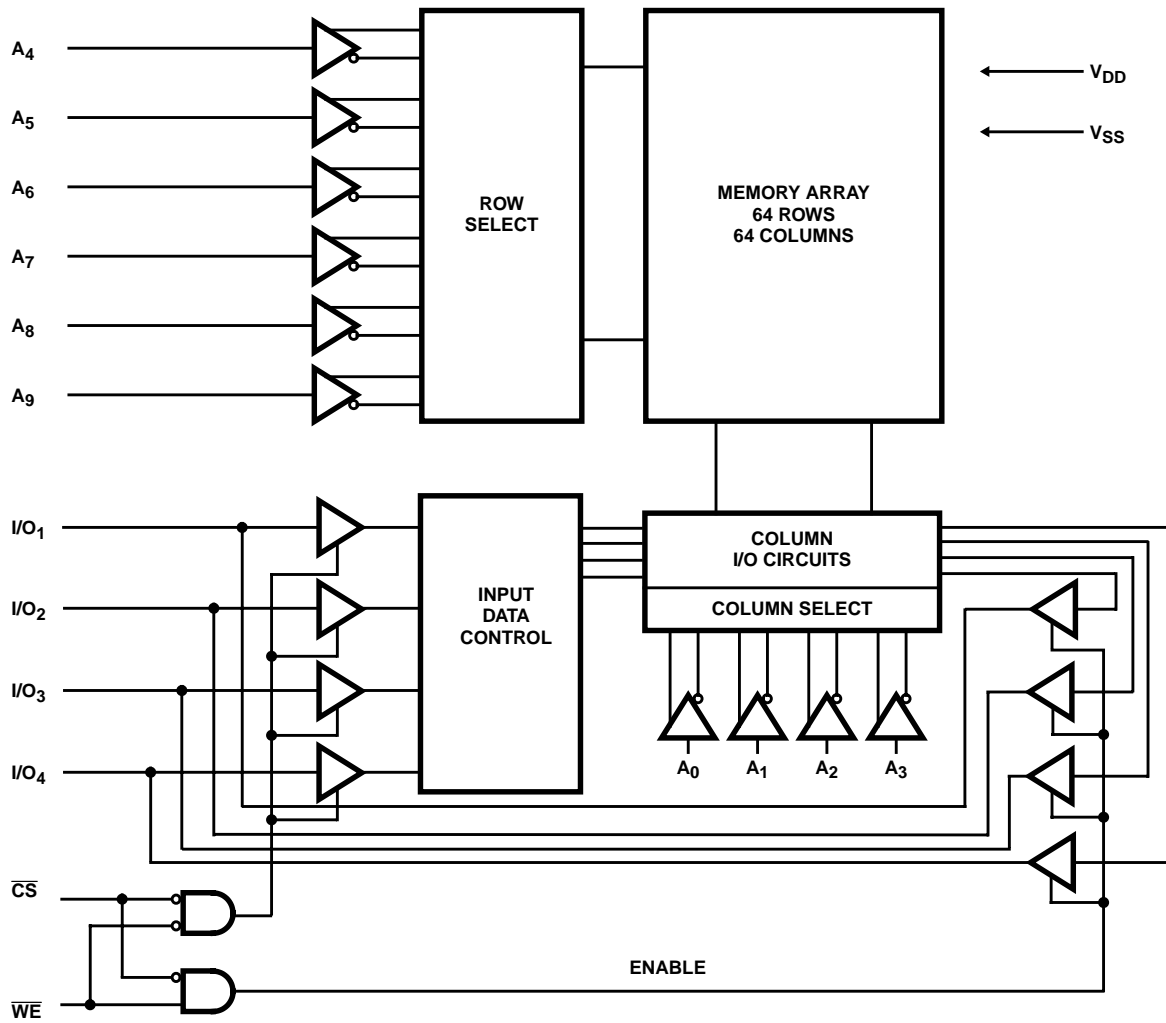

MWS5114

Absolute Maximum Ratings

DC Supply Voltage Range, (V_{DD})
 (All Voltages Referenced to V_{SS} Terminal) -0.5V to +7V
 Input Voltage Range, All Inputs -0.5V to $V_{DD} + 0.5V$
 DC Input Current, Any One Input. $\pm 10mA$

Thermal Information

Thermal Resistance (Typical) θ_{JA} ($^{\circ}C/W$) θ_{JC} ($^{\circ}C/W$)
 Plastic DIP Package 75 N/A
 SBDIP Package 75 20
 Operating Temperature Range (T_A)
 Package Type D $-55^{\circ}C$ to $+125^{\circ}C$
 Package Type E $-40^{\circ}C$ to $+85^{\circ}C$
 Maximum Storage Temperature Range (T_{STG}) $-65^{\circ}C$ to $+150^{\circ}C$
 Maximum Junction Temperature
 Ceramic Package $+175^{\circ}C$
 Plastic Package $+150^{\circ}C$
 Maximum Lead Temperature. $+265^{\circ}C$

Recommended Operating Conditions

At T_A = Full Package Temperature Range. For maximum reliability, operating conditions should be selected so that operation is always within the following ranges:

PARAMETER	LIMITS		UNITS
	ALL TYPES		
	MIN	MAX	
DC Operating Voltage Range	4.5	6.5	V
Input Voltage Range	V_{SS}	V_{DD}	V

Static Electrical Specifications

At $T_A = 0^{\circ}C$ to $+70^{\circ}C$, $V_{DD} = \pm 5\%$, Except as Noted

PARAMETER	SYMBOL	CONDITIONS			LIMITS									UNITS
		V_O (V)	V_{IN} (V)	V_{DD} (V)	MWS5114-3			MWS5114-2			MWS5114-1			
					MIN	(NOTE 1) TYP	MAX	MIN	(NOTE 1) TYP	MAX	MIN	(NOTE 1) TYP	MAX	
Quiescent Device Current	IDD	-	0, 5	5	-	75	100	-	75	100	-	75	250	μA
Output Low (Sink) Current	I_{OL}	0.4	0, 5	5	2	4	-	2	4	-	2	4	-	mA
Output High (Source) Current	I_{OH}	4.6	0, 5	5	-0.4	-1	-	-0.4	-1	-	-0.4	-1	-	mA
Output Voltage Low-Level	VOL	-	0, 5	5	-	0	0.1	-	0	0.1	-	0	0.1	V
Output Voltage High-Level	VOH	-	0, 5	5	4.9	5	-	4.9	5	-	4.9	5	-	V
Input Low Voltage	V_{IL}	0.5, 4.5	-	5	-	1.2	0.8	-	1.2	0.8	-	1.2	0.8	V
Input High Voltage	V_{IH}	0.5, 4.5	-	5	2.4	-	-	2.4	-	-	2.4	-	-	V
Input Leakage Current (Note 2)	IIN	-	0, 5	5	-	± 0.1	± 5	-	± 0.1	± 5	-	± 0.1	± 5	μA
Operating Current (Note 3)	IDD1	-	0, 5	5	-	4	8	-	4	8	-	4	8	mA

MWS5114

Static Electrical Specifications At $T_A = 0^{\circ}\text{C}$ to $+70^{\circ}\text{C}$, $V_{DD} = \pm 5\%$, Except as Noted (Continued)

PARAMETER	SYMBOL	CONDITIONS			LIMITS									UNITS
		V_O (V)	V_{IN} (V)	V_{DD} (V)	MWS5114-3			MWS5114-2			MWS5114-1			
					MIN	(NOTE 1) TYP	MAX	MIN	(NOTE 1) TYP	MAX	MIN	(NOTE 1) TYP	MAX	
Three-State Output Leakage Current (Note 4)	I_{OUT}	0, 5	0, 5	5	-	± 0.5	± 5	-	± 0.5	± 5	-	± 0.5	± 5	μA
Input Capacitance	C_{IN}	-	-	-	-	5	7.5	-	5	7.5	-	5	7.5	pF
Output Capacitance	C_{OUT}	-	-	-	-	10	15	-	10	15	-	10	15	pF

NOTES:

1. Typical values are for $T_A = 25^{\circ}\text{C}$ and nominal V_{DD} .
2. All inputs in parallel.
3. Outputs open circuited; cycle time = $1\mu\text{s}$.
4. All outputs in parallel.

MWS5114

Dynamic Electrical Specifications at $T_A = 0^\circ\text{C}$ to $+70^\circ\text{C}$, $V_{DD} = 5V \pm 5\%$, Input $t_R, t_F = 10\text{ns}$; $C_L = 50\text{pF}$ and 1 TTL Load

PARAMETER	SYMBOL	LIMITS									UNITS
		MWS5114-3			MWS5114-2			MWS5114-1			
		(NOTE 1) MIN	(NOTE 2) TYP	MAX	(NOTE 1) MIN	(NOTE 2) TYP	MAX	(NOTE 1) MIN	(NOTE 2) TYP	MAX	
READ CYCLE TIMES (FIGURE 1)											
Read Cycle	t _{RC}	200	160	-	250	200	-	300	250	-	ns
Access from Address	t _{AA}	-	160	200	-	200	250	-	250	300	ns
Chip Selection to Output Valid	t _{CO}	-	110	150	-	150	200	-	200	250	ns
Chip Selection to Output Active	t _{CX}	20	100	-	20	100	-	20	100	-	ns
Output Three-State from Deselection	t _{OTD}	-	75	125	-	75	125	-	75	125	ns
Output Hold from Address Change	t _{OHA}	50	100	-	50	100	-	50	100	-	ns
WRITE CYCLE TIMES (FIGURE 2)											
Write Cycle	t _{WC}	200	160	-	250	200	-	300	220	-	ns
Write	t _W	125	100	-	150	120	-	200	140	-	ns
Write Release	t _{WR}	50	40	-	50	40	-	50	40	-	ns
Address to Chip Select Setup Time	t _{ACS}	0	0	-	0	0	-	0	0	-	ns
Address to Write Setup Time	t _{AW}	25	20	-	50	40	-	50	40	-	ns
Data to Write Setup Time	t _{DSU}	75	50	-	75	50	-	75	50	-	ns
Data Hold from Write	t _{DH}	30	10	-	30	10	-	30	10	-	ns

NOTES:

1. Time required by a limit device to allow for the indicated function.
2. Typical values are for $T_A = 25^\circ\text{C}$ and nominal V_{DD} .

MWS5114

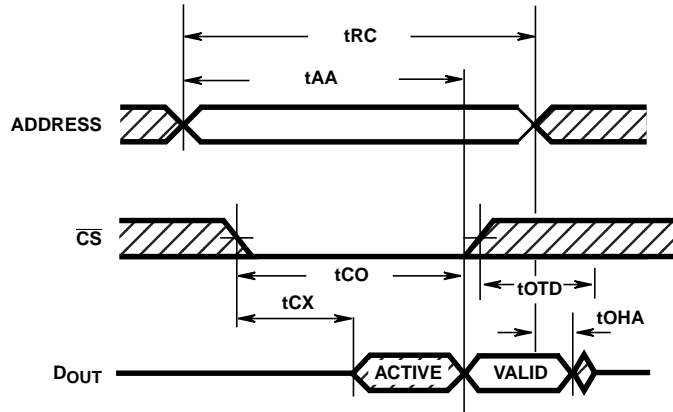

NOTE:

1. \overline{WE} is high during the Read Cycle. Timing measurement reference level is 1.5V.

FIGURE 1. READ CYCLE TIMING WAVEFORMS

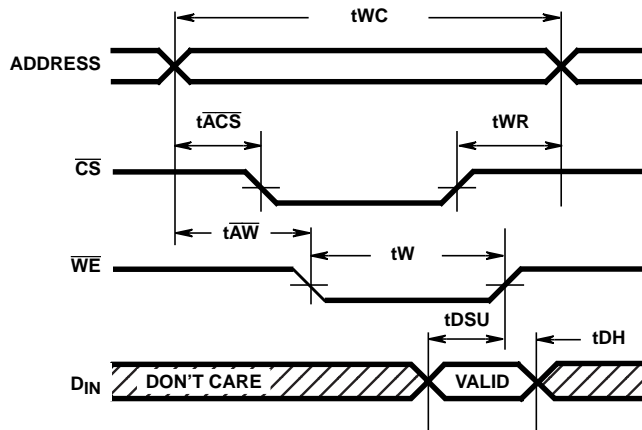

NOTE:

1. \overline{WE} is low during the Write Cycle. Timing measurement reference level is 1.5V.

FIGURE 2. WRITE CYCLE TIMING WAVEFORMS

Data Retention Specifications at $T_A = 0^\circ\text{C}$ to $+70^\circ\text{C}$; See Figure 3

PARAMETER	SYMBOL	TEST CONDITIONS		LIMITS			UNITS	
		V_{DR} (V)	V_{DD} (V)	ALL TYPES				
				MIN	(NOTE 1) TYP	MAX		
Minimum Data Retention Voltage	VDR	-	-	2	-	-	V	
Data Retention Quiescent Current	MWS5114-3	IDD	2	-	-	25	50	μA
	MWS5114-2		2	-	-	25	50	μA
	MWS5114-1		2	-	-	60	125	μA
Chip Deselect to Data Retention Time	tCDR	-	5	300	-	-	ns	
Recovery to Normal Operation Time	tRC	-	5	300	-	-	ns	
V_{DD} to V_{DR} Rise and Fall Time	t_R, t_F	2	5	1	-	-	μs	

NOTE:

1. Typical Values are for $T_A = 25^\circ\text{C}$ and nominal V_{DD} .

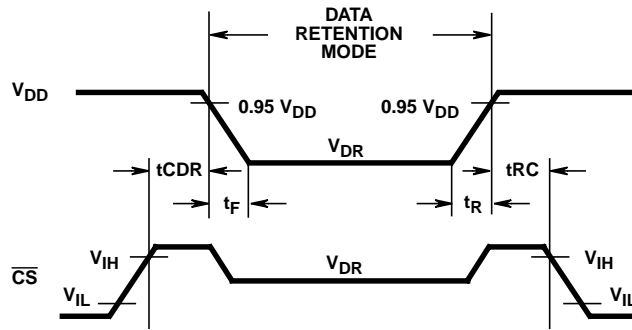
FIGURE 3. LOW V_{DD} DATA RETENTION TIMING WAVEFORMS

All Intersil semiconductor products are manufactured, assembled and tested under **ISO9000** quality systems certification.

Intersil products are sold by description only. Intersil Corporation reserves the right to make changes in circuit design and/or specifications at any time without notice. Accordingly, the reader is cautioned to verify that data sheets are current before placing orders. Information furnished by Intersil is believed to be accurate and reliable. However, no responsibility is assumed by Intersil or its subsidiaries for its use; nor for any infringements of patents or other rights of third parties which may result from its use. No license is granted by implication or otherwise under any patent or patent rights of Intersil or its subsidiaries.

For information regarding Intersil Corporation and its products, see web site <http://www.intersil.com>

Sales Office Headquarters

NORTH AMERICA

Intersil Corporation
P. O. Box 883, Mail Stop 53-204
Melbourne, FL 32902
TEL: (407) 724-7000
FAX: (407) 724-7240

EUROPE

Intersil SA
Mercure Center
100, Rue de la Fusée
1130 Brussels, Belgium
TEL: (32) 2.724.2111
FAX: (32) 2.724.22.05

ASIA

Intersil (Taiwan) Ltd.
Taiwan Limited
7F-6, No. 101 Fu Hsing North Road
Taipei, Taiwan
Republic of China
TEL: (886) 2 2716 9310
FAX: (886) 2 2715 3029