

16-bit Proprietary Microcontroller

CMOS

F²MC-16LX MB90480/485 Series

**MB90F481/F482/487B/488B/483B
MB90F488B/F489B/V480/V485B**

■ DESCRIPTION

The MB90480/485 series is a 16-bit general-purpose FUJITSU microcontroller designed for process control in consumer devices and other applications requiring high-speed real-time processing.

The F²MC-16LX CPU core instruction set retains the AT architecture of the F²MC*¹ family, with additional instructions for high-level languages, expanded addressing mode, enhanced multiply-drive instructions, and complete bit processing. In addition, a 32-bit accumulator is provided to enable long-word processing.

The MB90480/485 series features embedded peripheral resources including 8/16-bit PPG, expanded I/O serial interface, UART, 10-bit A/D converter, 16-bit I/O timer, 8/16-bit up/down-counter, PWC timer, I²C*² interface, DTP/external interrupt, chip select, and 16-bit reload timer.

*1 : F²MC, an abbreviation for FUJITSU Flexible Microcontroller, is a registered trademark of FUJITSU, Ltd.

*2 : Purchase of Fujitsu I²C components conveys a license under the Philips I²C Patent Rights to use, these components in an I²C system provided that the system conforms to the I²C stand a Specification as defined by Philips.

■ PACKAGES

100-pin plastic QFP

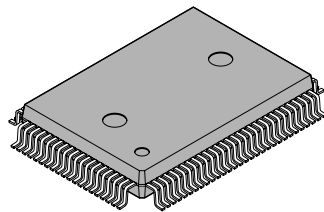

(FPT-100P-M06)

100-pin plastic LQFP

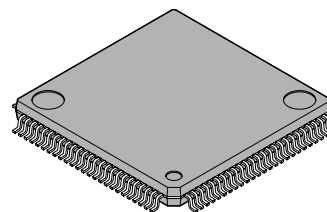

(FPT-100P-M05)

The FUJITSU logo, featuring the word "FUJITSU" in a bold, sans-serif font with a stylized infinity symbol above the letter "I".

MB90480/485 Series

■ FEATURES

- Clock
Minimum instruction execution time: 40.0 ns/6.25 MHz base frequency multiplied $\times 4$ (25 MHz internal operating frequency/3.3 V \pm 0.3 V)
62.5 ns/4 MHz base frequency multiplied $\times 4$ (16 MHz internal operating frequency/3.0 V \pm 0.3 V) PLL clock multiplier
- Maximum memory space: 16 Mbytes
- Instruction set optimized for controller applications
Supported data types (bit, byte, word, or long word)
Typical addressing modes (23 types)
Enhanced signed multiplication/division instruction and RETI instruction functions
32-bit accumulator for enhanced high-precision calculation
- Instruction set designed for high-level language (C) and multi-task operations
System stack pointer adopted
Instruction set compatibility and barrel shift instructions
- Non-multiplex bus/multiplex bus compatible
- Enhanced execution speed
4 byte instruction queue
- Enhanced interrupt functions
8 levels setting with programmable priority, 8 external interrupts
- Data transmission function (μ DMAC)
Up to 16 channels
- Embedded ROM
FLASH versions : 192 Kbytes, 256 Kbytes, 384 Kbytes, MASK versions : 192 Kbytes, 256 Kbytes
- Embedded RAM
FLASH versions : 4 Kbytes, 6 Kbytes, 10 Kbytes, 24 Kbytes, MASK versions : 10 Kbytes, 16 Kbytes
- General purpose ports
Up to 84 ports
(Except MB90V480 : Includes 16 ports with input pull-up resistance settings, 16 ports with output open-drain settings)
- A/D converter
8-channel RC sequential comparison type (10-bit resolution, 3.68 μ s conversion time (at 25 MHz))
- I²C interface (MB90485 series only) : 1 channel, P76/P77 Nch OD pin (without Pch)
Do not apply high voltage in excess of recommended operating ranges to the Nch open drain pin (with Pch) in MB90V485B.
- μ PG (MB90485 series only) : 1 channel
- UART : 1 channel
- Extended I/O serial interface : 2 channels
- 8/16-bit PPG : 3 channels (with 8-bit \times 6 channel/16-bit \times 3 channel mode switching function)
- 8/16-bit up/down timer: 1 channel (with 8-bit \times 2 channels/16-bit \times 1-channel mode switching function)
- PWC (MB90485 series only) : 3 channels (Capable of compare the inputs to two of the three)
- 3 V/5 V I/F pin (MB90485 series only)
P20 to P27, P30 to P37, P40 to P47, P70 to P77
- 16-bit reload timer : 1 channel
- 16-bit I/O timer : 2 channels input capture, 6 channels output compare, 1 channel free run timer
- On chip dual clock generator system
- Low-power consumption mode
With stop mode, sleep mode, CPU intermittent operation mode, watch mode, timebase timer mode
- Packages : QFP 100/LQFP 100
- Process : CMOS technology
- Power supply voltage : 3 V, single source (some ports can be operated by 5 V power supply at MB90485 series)

MB90480/485 Series

■ PRODUCT LINEUP

• MB90480 series

Part number		MB90F481	MB90F482	MB90V480
Item				
Classification		Flash memory product		Evaluation product
ROM size		FLASH 192 Kbytes	FLASH 256 Kbytes	—
RAM size		4 Kbytes	6 Kbytes	16 Kbytes
CPU function		Number of instructions : 351 Instruction bit length : 8-bit, 16-bit Instruction length : 1 byte to 7 bytes Data bit length : 1-bit, 8-bits, 16-bits Minimum execution time : 40 ns (25 MHz machine clock)		
Ports		General-purpose I/O ports: up to 84 General-purpose I/O ports (CMOS output) General-purpose I/O ports (with pull-up resistance) General-purpose I/O ports (Nch open drain)		
UART		1 channel, start-stop synchronized		
8/16-bit PPG timer		8-bit × 6 channels/16-bit × 3 channels		
8/16-bit up/down counter/timer		6 event input pins, 8-bit up/down counters : 2 8-bit reload/compare registers : 2		
16-bit I/O timers	16-bit free run timer	Number of channels : 1 Overflow interrupt		
	Output compare (OCU)	Number of channels : 6 Pin input factor : A match signal of compare register		
	Input capture (ICU)	Number of channels : 2 Rewriting a register value upon a pin input (rising, falling, or both edges)		
DTP/external interrupt circuit		Number of external interrupt channels : 8 (edge or level detection)		
Extended I/O serial interface		2 channels, embedded		
Timebase timer		18-bit counter Interrupt cycles: 1.0 ms, 4.1 ms, 16.4 ms, 131.1 ms (at 4 MHz base oscillator)		
A/D converter		Conversion resolution : 8/10-bit, switchable One-shot conversion mode (converts selected channel 1 time only) Scan conversion mode (conversion of multiple consecutive channels, programmable up to 8 channels) Continuous conversion mode (repeated conversion of selected channels) Stop conversion mode (conversion of selected channels with repeated pause)		
Watchdog timer		Reset generation interval : 3.58 ms, 14.33 ms, 57.23 ms, 458.75 ms (minimum value, at 4 MHz base oscillator)		
Low-power consumption (standby) modes		Sleep mode, stop mode, CPU intermittent mode, watch timer mode, timebase timer mode		
Process		CMOS		
Type		Not included security function		User terminal*1, 3 V/5 V versions
Emulator power supply*2		—		Included

*1 : User terminal : P20 to P27, P30 to P37, P40 to P47, P70 to P77

*2 : It is setting of Jumper switch (TOOL VCC) when emulator (MB2147-01) is used.
Please refer to the MB2147-01 or MB2147-20 hardware manual (3.3 Emulator-dedicated Power Supply switching) about details.

Note : Ensure that you must to FLASH at $V_{CC} = 3.13 \text{ V to } 3.60 \text{ V}$ ($3.3 \text{ V} + 10\%$, -5%) .

MB90480/485 Series

• MB90485 series

Part number Item	MB90487B	MB90488B	MB90F488B	MB90V485B	MB90F489B	MB90483B
Classification	Mask ROM product		Flash memory product	Evaluation product	Flash memory product	Mask ROM product
ROM size	192 Kbytes	256 Kbytes	256 Kbytes	—	384 Kbytes	256 Kbytes
RAM size	10 Kbytes	10 Kbytes	10 Kbytes	16 Kbytes	24 Kbytes	16 Kbytes
CPU function	Number of instructions : 351 Instruction bit length : 8-bit, 16-bit Instruction length : 1 byte to 7 bytes Data bit length : 1-bit, 8-bits, 16-bits Minimum execution time : 40 ns (25 MHz machine clock)					
Ports	General-purpose I/O ports : up to 84 General-purpose I/O ports (CMOS output) General-purpose I/O ports (with pull-up resistance) General-purpose I/O ports (Nch open drain)					
UART	1 channel, start-stop synchronized					
8/16-bit PPG timer	8-bit × 6 channels/16-bit × 3 channels					
8/16-bit up/down counter/timer	6 event input pins, 8-bit up/down counters : 2 8-bit reload/compare registers : 2					
16-bit I/O timers	16-bit free run timer	Number of channels : 1 Overflow interrupt				
	Output compare (OCU)	Number of channels : 6 Pin input factor: A match signal of compare register				
	Input capture (ICU)	Number of channels : 2 Rewriting a register value upon a pin input (rising, falling, or both edges)				
DTP/external interrupt circuit	Number of external interrupt channels: 8 (edge or level detection)					
Extended I/O serial interface	2 channels, embedded					
I ² C interface*2	1 channel					
μPG	1 channel					
PWC	3 channels					
Timebase timer	18-bit counter Interrupt cycles : 1.0 ms, 4.1 ms, 16.4 ms, 131.1 ms (at 4 MHz base oscillator)					
A/D converter	Conversion resolution : 8/10-bit, switchable One-shot conversion mode (converts selected channel 1 time only) Scan conversion mode (conversion of multiple consecutive channels, programmable up to 8 channels) Continuous conversion mode (repeated conversion of selected channels) Stop conversion mode (conversion of selected channels with repeated pause)					

(Continued)

MB90480/485 Series

(Continued)

Item \ Part number	MB90487B	MB90488B	MB90F488B	MB90V485B	MB90F489B	MB90483B
Watchdog timer	Reset generation interval: 3.58 ms, 14.33 ms, 57.23 ms, 458.75 ms (minimum value, at 4 MHz base oscillator)					
Low-power consumption (standby) modes	Sleep mode, stop mode, CPU intermittent mode, watch timer mode, timebase timer mode					
Process	CMOS					
Type	3 V/5 V power supply*1	3 V/5 V power supply*1	3 V/5 V power supply*1 Included security function	3 V/5 V power supply*1	3 V/5 V power supply*1 Included security function	3 V/5 V power supply*1
Emulator power supply*3	—	—	—	Included	—	—

*1 : 3 V/5 V I/F pin : All pins should be for 3 V power supply without P20 to P27, P30 to P37, P40 to P47, and P70 to P77.

*2 : P76/P77 pins are Nch open drain pins (without Pch) at built-in I²C. However, MB90V485B uses the Nch open drain pin (with Pch) .

*3 : It is setting of Jumper switch (TOOL VCC) when Emulator (MB2147-01) is used.
Please refer to the MB2147-01 or MB2147-20 hardware manual (3.3 Emulator-dedicated Power Supply Switching) about details.

Notes : • As for MB90V485B, Input pins (PWC0, PWC1, PWC2/EXTC/SCL and SDA pins) for PWC/ μ PG/I²C become CMOS input.
• Ensure that you must to FLASH at $V_{CC} = 3.13 \text{ V to } 3.60 \text{ V}$ ($3.3 \text{ V} + 10\%, - 5\%$) .

MB90480/485 Series

PIN ASSIGNMENT

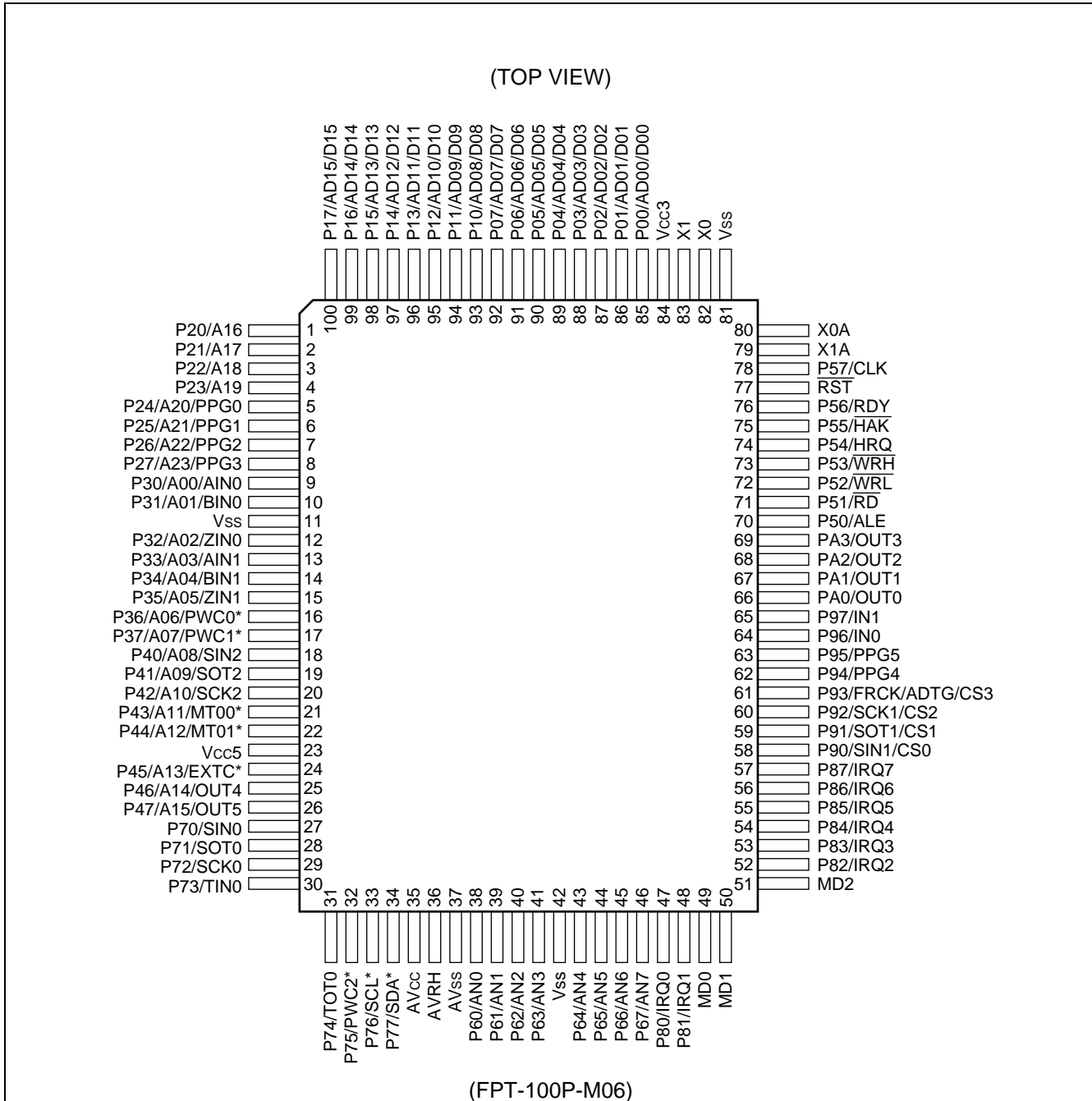

* : These are the pins for MB90485 series. The pins for MB90480 series are P36/A06, P37/A07, P43/A11, P44/A12, P45/A13, P75, P76 and P77.

Note : MB90485 series only

- I²C pin P77 and P76 are Nch open drain pin (without Pch) . However, MB90V485B uses the Nch open drain pin (with Pch) .
- P20 to P27, P30 to P37, P40 to P47 and P70 to P77 also used as 3 V/5 V I/F pin.
- As for MB90V485B, input pins (PWC0, PWC1, PWC2/EXTC/SCL and SDA pins) for PWC/ μ PG/I²C become CMOS input.

(TOP VIEW)

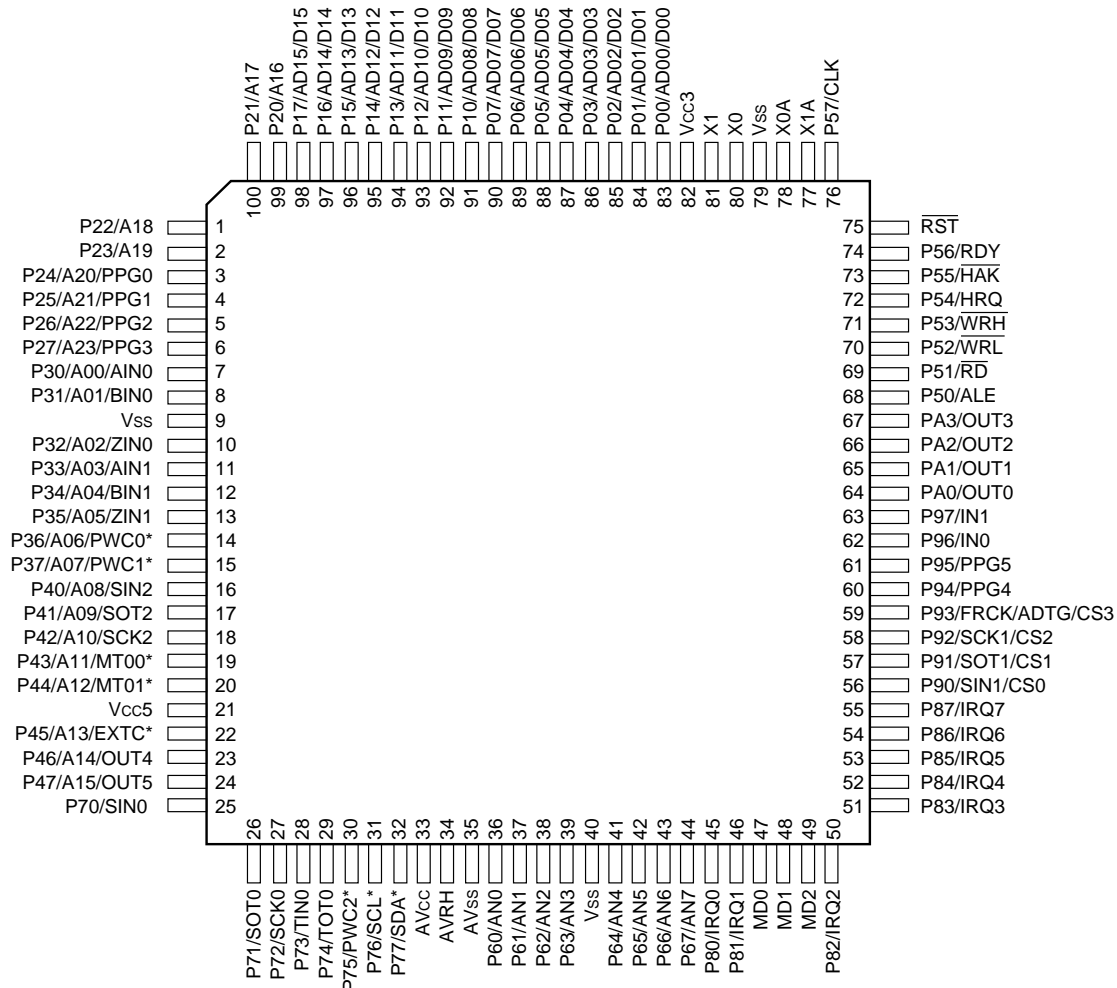

(FPT-100P-M05)

* : These are the pins for MB90485 series. The pins for MB90480 series are P36/A06, P37/A07, P43/A11, P44/A12, P45/A13, P75, P76 and P77.

Note : MB90485 series only

- I²C pin P77 and P76 are Nch open drain pin (without Pch) . However, MB90V485B uses the Nch open drain pin (with Pch) .
- P20 to P27, P30 to P37, P40 to P47 and P70 to P77 also used as 3 V/5 V I/F pin.
- As for MB90V485B, input pins (PWC0, PWC1, PWC2/EXTC/SCL and SDA pins) for PWC/ μ PG/I²C become CMOS input.

MB90480/485 Series

■ PIN DESCRIPTIONS

Pin No.		Pin name	Circuit type	Function
LQFP*1	QFP*2			
80	82	X0	A	Oscillator pin
81	83	X1	A	Oscillator pin
78	80	X0A	A	32 kHz oscillator pin
77	79	X1A	A	32 kHz oscillator pin
75	77	\overline{RST}	B	Reset input pin
83 to 90	85 to 92	P00 to P07	C (CMOS)	This is a general purpose I/O port. A setting in the pull-up resistance setting register (RDR0) can be used to apply pull-up resistance (RD00-RD07 = "1") . (Disabled when pin is set for output.)
		AD00 to AD07		In multiplex mode, these pins function as the external address/data bus low I/O pins.
		D00 to D07		In non-multiplex mode, these pins function as the external data bus low output pins.
91 to 98	93 to 100	P10 to P17	C (CMOS)	This is a general purpose I/O port. A setting in the pull-up resistance setting register (RDR1) can be used to apply pull-up resistance (RD10-RD17 = "1") . (Disabled when pin is set for output.)
		AD08 to AD15		In multiplex mode, these pins function as the external address/data bus high I/O pins.
		D08 to D15		In non-multiplex mode, these pins function as the external data bus high output pins.
99 100 1 2	1 to 4	P20 to P23	E (CMOS/H)	This is a general purpose I/O port. When the bits of external address output control register (HACR) are set to "1" in external bus mode, these pins function as general purpose I/O ports.
		A16 to A19		When the bits of external address output control register (HACR) are set to "0" in multiplex mode, these pins function as address high output pins (A16-A19).
		A16 to A19		When the bits of external address output control register (HACR) are set to "0" in non-multiplex mode, these pins function as address high output pins (A16-A19).
3 to 6	5 to 8	P24 to P27	E (CMOS/H)	This is a general purpose I/O port. When the bits of external address output control register (HACR) are set to "1" in external bus mode, these pins function as general purpose I/O ports.
		A20 to A23		When the bits of external address output control register (HACR) are set to "0" in multiplex mode, these pins function as address high output pins (A20-A23).
		A20 to A23		When the bits of external address output control register (HACR) are set to "0" in non-multiplex mode, these pins function as address high output pins (A20-A23).
		PPG0 to PPG3		PPG timer output pins.
7	9	P30	E (CMOS/H)	This is a general purpose I/O port.
		A00		In non-multiplex mode, this pin functions as an external address pin.
		AIN0		8/16-bit up/down timer input pin (channel 0) .

(Continued)

MB90480/485 Series

Pin No.		Pin name	Circuit type	Function			
LQFP*1	QFP*2						
8	10	P31	E	(CMOS/H)	This is a general purpose I/O port.		
		A01			In non-multiplex mode, this pin functions as an external address pin.		
		BIN0			8/16-bit up/down counter input pin (channel 0) .		
10	12	P32	E	(CMOS/H)	This is a general purpose I/O port.		
		A02			In non-multiplex mode, this pin functions as an external address pin.		
		ZIN0			8/16-bit up/down counter input pin (channel 0)		
11	13	P33	E	(CMOS/H)	This is a general purpose I/O port.		
		A03			In non-multiplex mode, this pin functions as an external address pin.		
		AIN1			8/16-bit up/down counter input pin (channel 1) .		
12	14	P34	E	(CMOS/H)	This is a general purpose I/O port.		
		A04			In non-multiplex mode, this pin functions as an external address pin.		
		BIN1			8/16-bit up/down counter input pin (channel 1) .		
13	15	P35	E	(CMOS/H)	This is a general purpose I/O port.		
		A05			In non-multiplex mode, this pin functions as an external address pin.		
		ZIN1			8/16-bit up/down counter input pin (channel 1)		
14 15	16 17*3	P36, P37	D	(CMOS)	MB90480 series	This is a general purpose I/O port.	
		A06, A07					In non-multiplex mode, this pin functions as an external address pin.
		P36, P37	E	(CMOS/H)	MB90485 series	This is a general purpose I/O port.	
		A06, A07					In non-multiplex mode, this pin functions as an external address pin.
		PWC0, PWC1					This is a PWC input pin.
16	18	P40	G	(CMOS/H)	This is a general purpose I/O port.		
		A08			In non-multiplex mode, this pin functions as an external address pin.		
		SIN2			Extended I/O serial interface input pin.		
17	19	P41	F	(CMOS)	This is a general purpose I/O port.		
		A09				In non-multiplex mode, this pin functions as an external address pin.	
		SOT2				Extended I/O serial interface output pin.	
18	20	P42	G	(CMOS/H)	This is a general purpose I/O port.		
		A10			In non-multiplex mode, this pin functions as an external address pin.		
		SCK2			Extended I/O serial interface clock input/output pin.		
19 20	21 22	P43, P44	F	(CMOS)	MB90480 series	This is a general purpose I/O port.	
		A11, A12					In non-multiplex mode, this pin functions as an external address pin.
		P43, P44	F	(CMOS)	MB90485 series	This is a general purpose I/O port.	
		A11, A12					In non-multiplex mode, this pin functions as an external address pin.
		MT00, MT01					μPG output pin.

(Continued)

MB90480/485 Series

Pin No.		Pin name	Circuit type	Function	
LQFP*1	QFP*2				
22	24	P45	F (CMOS)	MB90480 series	This is a general purpose I/O port.
		A13			In non-multiplex mode, this pin functions as an external address pin.
		P45	G (CMOS/ H)	MB90485 series	This is a general purpose I/O port.
		A13			In non-multiplex mode, this pin functions as an external address pin.
		EXTC*3			μPG input pin (MB90485 series only) .
23 24	25 26	P46, P47	F (CMOS)		This is a general purpose I/O port.
		A14, A15			In non-multiplex mode, this pin functions as an external address pin.
		OUT4/ OUT5			Output compare event output pins.
68	70	P50	D (CMOS)		This is a general purpose I/O port. In external bus mode, this pin functions as the ALE pin.
		ALE			In external bus mode, this pin functions as the address load enable (ALE) signal pin.
69	71	P51	D (CMOS)		This is a general purpose I/O port. In external bus mode, this pin functions as the RD pin.
		\overline{RD}			In external bus mode, this pin functions as the read strobe output (\overline{RD} signal pin).
70	72	P52	D (CMOS)		This is a general purpose I/O port. In external bus mode, when the WRE pin in the EPCR register is set to "1", this pin functions as the WRL pin.
		\overline{WRL}			In external bus mode, this pin functions as the lower data write strobe output (\overline{WRL}) pin. When the WRE bit in the EPCR register is set to "0", this pin functions as a general purpose I/O port.
71	73	P53	D (CMOS)		This is a general purpose I/O port. In external bus mode with 16-bit bus width, when the WRE bit in the EPCR register is set to "1", this pin functions as the \overline{WRH} pin.
		\overline{WRH}			In external bus mode with 16-bit bus width, this pin functions as the upper data write strobe output (\overline{WRH}) pin. When the WRE bit in the EPCR register is set to "0", this pin functions as a general purpose I/O port.
72	74	P54	D (CMOS)		This is a general purpose I/O port. In external bus mode, when the HDE bit in the EPCR register is set to "1", this pin functions as the HRQ pin.
		HRQ			In external bus mode, this pin functions as the hold request input (HRQ) pin. When the HDE bit in the EPCR register is set to "0", this pin functions as a general purpose I/O port.
73	75	P55	D (CMOS)		This is a general purpose I/O port. In external bus mode, when the HDE bit in the EPCR register is set to "1", this pin functions as the \overline{HAK} pin.
		\overline{HAK}			In external bus mode, this pin functions as the hold acknowledge (HAK) pin. When the HDE bit in the EPCR register is set to "0", this pin functions as a general purpose I/O port.

(Continued)

MB90480/485 Series

Pin No.		Pin name	Circuit type	Function	
LQFP*1	QFP*2				
74	76	P56	D (CMOS)	This is a general purpose I/O port. In external bus mode, when the RYE bit in the EPCR register is set to "1", this pin functions as the RDY pin.	
		RDY		In external bus mode, this pin functions as the external ready (RDY) input pin. When the RYE bit in the EPCR register is set to "0", this pin functions as a general purpose I/O port.	
76	78	P57	D (CMOS)	This is a general purpose I/O port. In external bus mode, when the CKE bit in the EPCR register is set to "1", this pin functions as the CLK pin.	
		CLK		In external bus mode, this pin functions as the machine cycle clock (CLK) output pin. When the CKE bit in the EPCR register is set to "0", this pin functions as a general purpose I/O port.	
36 to 39	38 to 41	P60 to P63	H (CMOS)	These are general purpose I/O ports.	
		AN0 to AN3		These are the analog input pins.	
41 to 44	43 to 46	P64 to P67	H (CMOS)	These are general purpose I/O ports.	
		AN4 to AN7		These are the analog input pins.	
25	27	P70	G (CMOS/ H)	This is a general purpose I/O port.	
		SIN0		This is the UART data input pin.	
26	28	P71	F (CMOS)	This is a general purpose I/O port.	
		SOT0		This is the UART data output pin.	
27	29	P72	G (CMOS/ H)	This is a general purpose I/O port.	
		SCK0		This is the UART clock I/O pin.	
28	30	P73	G (CMOS/ H)	This is a general purpose I/O port.	
		TIN0		This is the 16-bit reload timer event input pin.	
29	31	P74	F (CMOS)	This is a general purpose I/O port.	
		TOT0		This is the 16-bit reload timer output pin.	
30	32	P75	F (CMOS)	MB90480 series	This is a general purpose I/O port.
		P75	G (CMOS/ H)	MB90485 series	This is a general purpose I/O port.
		PWC2*3			This is a PWC input pin.
31	33	P76	F (CMOS)	MB90480 series	This is a general purpose I/O port.
		P76	I (NMOS/ H)	MB90485 series	This is a general purpose I/O port.
		SCL*3			Serves as the I ² C interface data I/O pin. During operation of the I ² C interface, leave the port output in a high impedance state.
32	34	P77	F (CMOS)	MB90480 series	This is a general purpose I/O port.
		P77	I (NMOS/ H)	MB90485 series	This is a general purpose I/O port.
		SDA*3			Serves as the I ² C interface data I/O pin. During operation of the I ² C interface, leave the port output in a high impedance state.
45 46	47 48	P80, P81 IRQ0, IRQ1	E (CMOS/ H)	These are general purpose I/O ports.	
		External interrupt input pins.			

(Continued)

MB90480/485 Series

(Continued)

Pin No.		Pin name	Circuit type	Function
LQFP*1	QFP*2			
50 to 55	52 to 57	P82 to P87	E (CMOS/H)	These are general purpose I/O ports.
		IRQ2 to IRQ7		External interrupt input pins.
56	58	P90	E (CMOS/H)	This is a general purpose I/O port.
		SIN1		Extended I/O serial interface data input pin.
		CS0		Chip select 0.
57	59	P91	D (CMOS)	This is a general purpose I/O port.
		SOT1		Extended I/O serial interface data output pin.
		CS1		Chip select 1.
58	60	P92	E (CMOS/H)	This is a general purpose I/O port.
		SCK1		Extended I/O serial interface clock input/output pin.
		CS2		Chip select 2.
59	61	P93	E (CMOS/H)	This is a general purpose I/O port.
		FRCK		When the free run timer is in use, this pin functions as the external clock input pin.
		ADTG		When the A/D converter is in use, this pin functions as the external trigger input pin.
		CS3		Chip select 3.
60	62	P94	D (CMOS)	This is a general purpose I/O port.
		PPG4		PPG timer output pin.
61	63	P95	D (CMOS)	This is a general purpose I/O port.
		PPG5		PPG timer output pin.
62	64	P96	E (CMOS/H)	This is a general purpose I/O port.
		IN0		Input capture channel 0 trigger input pin.
63	65	P97	E (CMOS/H)	This is a general purpose I/O port.
		IN1		Input capture channel 1 trigger input pin.
64 to 67	66 to 69	PA0 to PA3	D (CMOS)	These are general purpose I/O ports.
		OUT0 to OUT3		Output compare event output pins.
33	35	AV _{cc}	—	A/D converter power supply pin.
34	36	AV _{RH}	—	A/D converter external reference voltage supply pin.
35	37	AV _{ss}	—	A/D converter power supply pin.
47 to 49	49 to 51	MD0 to MD2	J (CMOS/H)	Operating mode selection input pins.
82	84	V _{cc3}	—	3.3 V ± 0.3 V power supply pins (V _{cc3}) .
21	23	V _{cc5}	—	MB90480 series 3.3 V ± 0.3 V power supply pin. Usually, use V _{cc} = V _{cc3} = V _{cc5} as a 3 V power supply.
				MB90485 series 3 V/5 V power supply pin. 5 V power supply pin when P20 to P27, P30 to P37, P40 to P47, P70 to P77 are used as 5 V I/F pins. Usually, use V _{cc} = V _{cc3} = V _{cc5} as a 3 V power supply (when the 3 V power supply is used alone) .
9 40 79	11 42 81	V _{ss}	—	Power supply input pins (GND) .

*1 : LQFP : FPT-100P-M05

*2 : QFP : FPT-100P-M06

*3 : As for MB90V485B, input pins become CMOS input.

■ I/O CIRCUIT TYPES

Type	Circuit	Remarks
A	<p>X1, X1A X0, X0A Standby control signal</p>	<p>Oscillator feedback resistance X1, X0 : approx. 1 MΩ X1A, X0A : approx. 10 MΩ with standby control</p>
B	<p>HYS</p>	<p>Hysteresis input with pull-up resistance</p>
C	<p>CTL CMOS</p>	<p>With input pull-up resistance control CMOS level input/output</p>
D	<p>CMOS</p>	<p>CMOS level input/output</p>
E	<p>CMOS</p>	<p>Hysteresis input CMOS level output</p>

(Continued)

MB90480/485 Series

(Continued)

Type	Circuit	Remarks
F	<p>Open drain control signal</p> <p>CMOS</p>	CMOS level input/output with open drain control
G	<p>Open drain control signal</p> <p>HYS</p>	CMOS level output Hysteresis input With open drain control
H	<p>Open drain control signal</p> <p>CMOS</p> <p>Analog input</p>	CMOS level input/output Analog input
I	<p>Digital output</p>	Hysteresis input Nch open drain output
J	<p>FLASH model</p> <p>Control signal</p> <p>Mode input</p> <p>Diffusion resistance</p>	(FLASH model) CMOS level input with high voltage control for flash testing
	<p>MASK model</p> <p>Hysteresis input</p>	(Mask model) Hysteresis input

■ HANDLING DEVICES

1. Be careful never to exceed maximum rated voltages (preventing latchup)

In CMOS IC devices, a condition known as latchup may occur if voltages higher than V_{CC} or lower than V_{SS} are applied to input or output pins other than medium- or high-voltage pins, or if the voltage applied between V_{CC} and V_{SS} exceeds the rated voltage level.

When latchup occurs, the power supply current increases rapidly causing the possibility of thermal damage to circuit elements. Therefore it is necessary to ensure that maximum ratings are not exceeded in circuit operation. Similarly, when turning the analog power supply on or off, it is necessary to ensure that the analog power supply voltages (AV_{CC} and AV_{RH}) and analog input voltages do not exceed the digital power supply (V_{CC}).

2. Treatment of unused pins

Leaving unused input pins unconnected can cause abnormal operation or latchup, leading to permanent damage. Unused input pins should always be pulled up or down through resistance of at least 2 k Ω . Any unused input/output pins may be set to output mode and left open, or set to input mode and treated the same as unused input pins.

3. Notes on Using External Clock

Even when using an external clock signal, an oscillation stabilization delay is applied after a power-on reset or when recovering from sub-clock or stop mode. When using an external clock, 25 MHz should be the upper frequency limit.

The following figure shows a sample use of external clock signals.

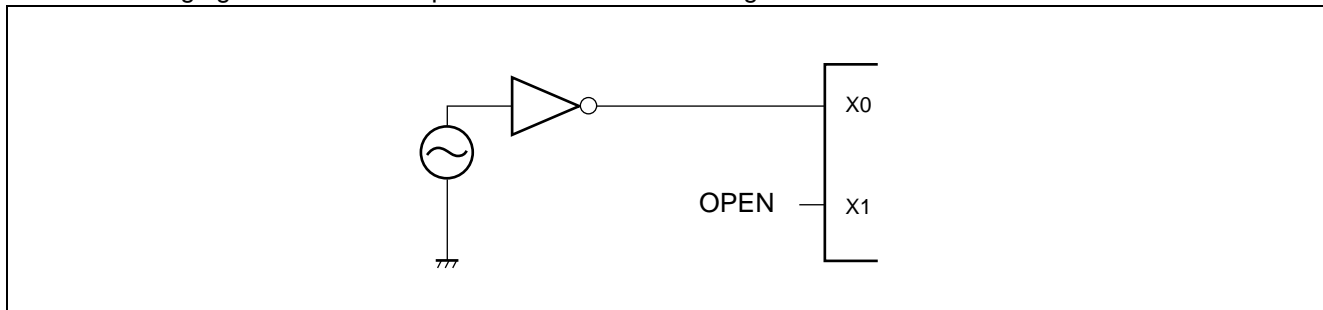

4. Treatment of Power Supply Pins (V_{CC}/V_{SS})

When multiple V_{CC}/V_{SS} pins are present, device design considerations for prevention of latch-up and unwanted electromagnetic interference, abnormal strobe signal operation due to ground level rise, and conformity with total output current ratings require that all power supply pins must be externally connected to power supply or ground.

Consideration should be given to connecting power supply sources to the V_{CC}/V_{SS} terminals of this device with as low impedance as possible. It is also recommended that a bypass capacitor of approximately 0.1 μF be placed between the V_{CC} and V_{SS} lines as close to this device as possible.

5. Crystal Oscillator Circuits

Noise around the X0/X1, or X0A/X1A pins may cause this device to operate abnormally. In the interest of stable operation it is strongly recommended that printed circuit artwork places ground bypass capacitors as close as possible to the X0/X1, X0A/X1A and crystal oscillator (or ceramic oscillator) and that oscillator lines do not cross the lines of other circuits.

MB90480/485 Series

6. Notes on during operation of PLL clock mode

If the PLL clock mode is selected, the microcontroller attempt to be working with the self-oscillating circuit even when there is no external oscillator or external clock input is stopped. Performance of this operation, however, cannot be guaranteed.

7. Proper power-on/off sequence

The A/D converter power (AV_{CC} , $AVRH$) and analog input (AN0 to AN7) must be turned on after the digital power supply (V_{CC}) is turned on. The A/D converter power (AV_{CC} , $AVRH$) and analog input (AN0 to AN7) must be shut off before the digital power supply (V_{CC}) is shut off. Care should be taken that $AVRH$ does not exceed AV_{CC} . Even when pins used as analog input pins are doubled as input ports, be sure that the input voltage does not exceed AV_{CC} .

8. Treatment of power supply pins on models with A/D converters

Even when the A/D converters are not in use, be sure to make the necessary connections $AV_{CC} = AVRH = V_{CC}$, and $AV_{SS} = V_{SS}$.

9. Precautions when turning the power supply on

In order to prevent abnormal operation in the chip's internal step-down circuits, a voltage rise time during power-on of 50 μ s (0.2 V to 2.7 V) or greater should be assured.

10. Supply Voltage Stabilization

Even within the operating range of V_{CC} supply voltage, rapid voltage fluctuations may cause abnormal operation. As a standard for power supply voltage stability, it is recommended that the peak-to-peak V_{CC} ripple voltage at commercial supply frequency (50 Hz to 60 Hz) be 10 % or less of V_{CC} , and that the transient voltage fluctuation be no more than 0.1 V/ms or less when the power supply is turned on or off.

11. Notes on Using Power Supply

Only the MB90485 series usually uses a 3 V power supply. By setting $V_{CC3} = 3$ V power supply and $V_{CC5} = 5$ V power supply, P20 to P27, P30 to P37, P40 to P47 and P70 to P77 can be interfaced as 5 V power supplies separately from the main 3 V power supply. Note that the analog power supplies (such as AV_{CC} and AV_{SS}) for the A/D converter can be used only as 3 V power supplies.

Programming into FLASH memory must be performed at an operating voltage (V_{CC}) between 3.13 V and 3.6 V.

12. Treatment of N.C. pins

N.C. (internally connected) pins should always be left open.

13. When the MB90480/485 series microcontroller is used as a single system

When the MB90480/485 series microcontroller is used as a single system, use connections so the X0A = V_{SS} , and X1A = Open.

14. Writing to FLASH memory

For serial writing to FLASH memory, always ensure that the operating voltage V_{CC} is between 3.13 V and 3.6 V. For normal writing to FLASH memory, always ensure that the operating voltage V_{CC} is between 3.0 V and 3.6 V.

■ BLOCK DIAGRAM

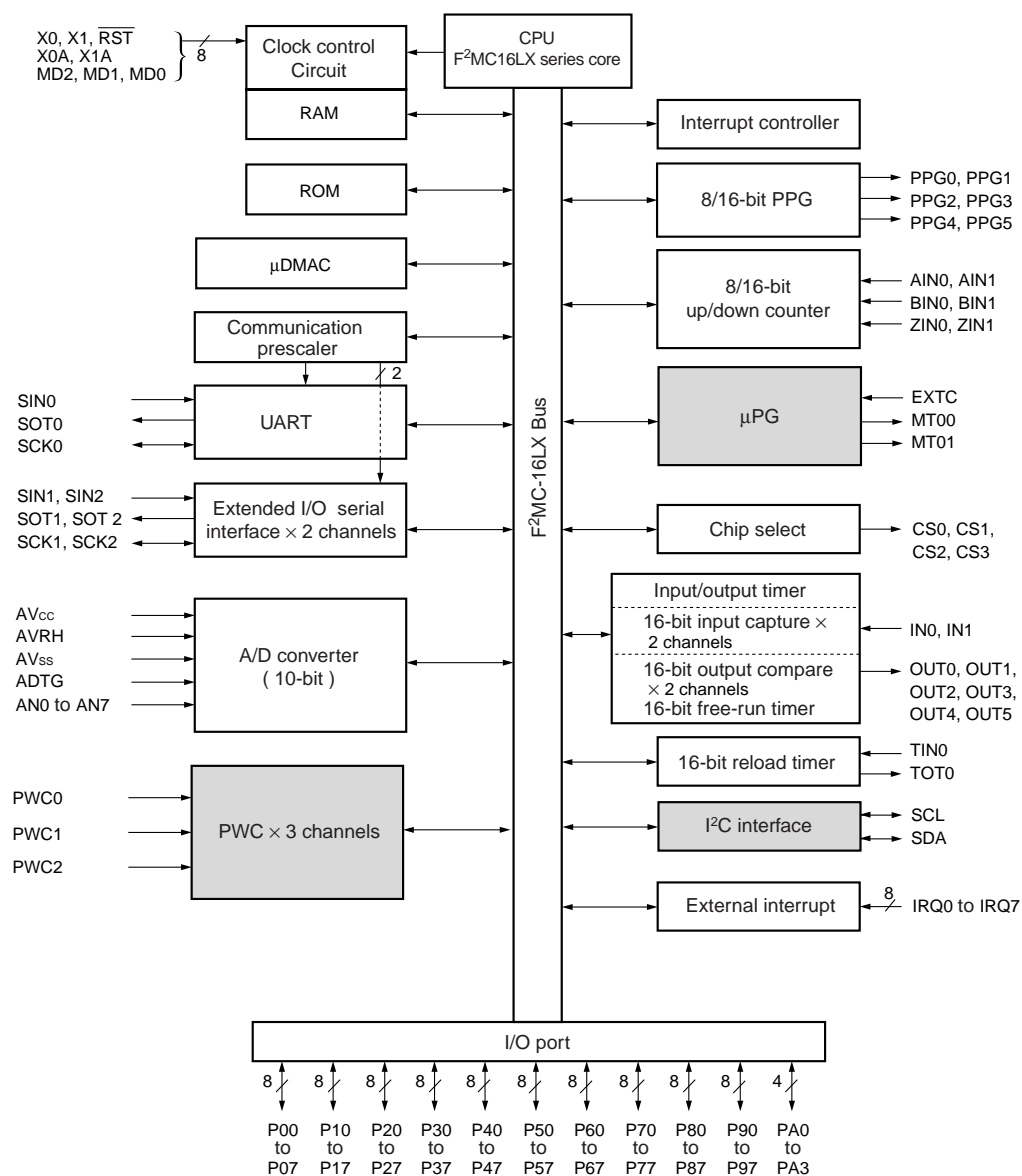

 : Only MB90485 series

- P00 to P07 (8 pins) : with an input pull-up resistance setting register.
- P10 to P17 (8 pins) : with an input pull-up resistance setting register.
- P40 to P47 (8 pins) : with an open drain setting register.
- P70 to P75 (6 pins) : with an open drain setting register.

MB90485 series only

- I²C pin P77 and P76 are Nch open drain pin (without Pch) . However, MB90V485B uses the Nch open drain pin (with Pch) .
- P20 to P27, P30 to P37, P40 to P47 and P70 to P77 also used as 3 V/5 V I/F pin.
- As for MB90V485B, input pins (PWC0, PWC1, PWC2/EXTC/SCL and SDA pins) for PWC/μPG/I²C become CMOS input.

Note : In the above diagram, I/O ports share internal function blocks and pins. However, when a set of pins is used with an internal module, it cannot also be used as an I/O port.

MB90480/485 Series

MEMORY MAP

• MB90F481/F482/487B/488B/483B/F488B/V480/V485B

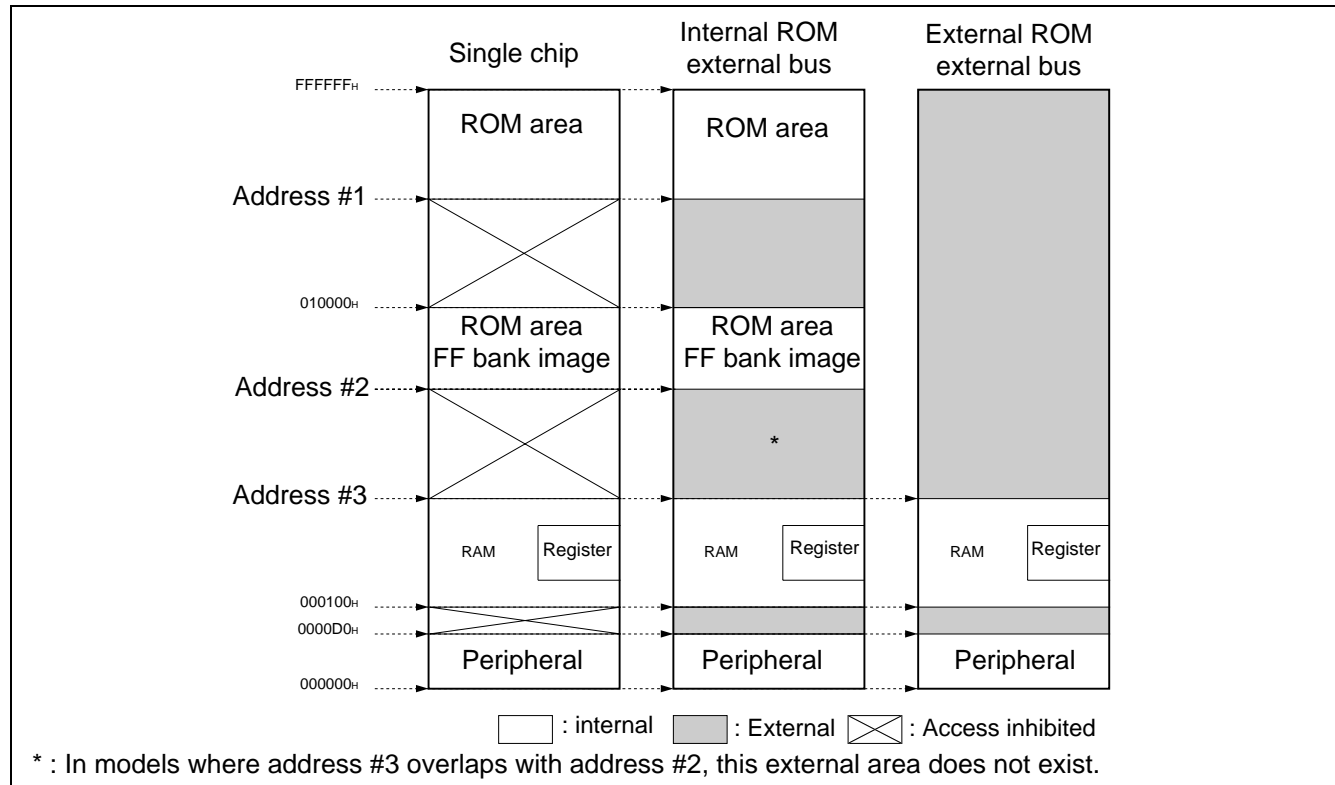

Model	Address #1	Address #2	Address #3
MB90F481	FC0000H ^{*1}	004000H or 008000H, selected by the MS bit in the ROMM register	001100H
MB90F482	FC0000H		001900H
MB90487B	FD0000H		002900H
MB90488B	FC0000H		002900H
MB90F488B	FC0000H		002900H
MB90V480	(FC0000H)		004000H
MB90V485B	(FC0000H)		004000H
MB90483B	FC0000H		004000H
MB90F489B	F90000H ^{*2}	0080000H fixed	006100H ^{*3}

^{*1} : No memory cells from FC0000H to FC7FFFH and FE0000H to FE7FFFH.

The upper part of the 00 bank is set up to mirror the image of FF bank ROM, to enable efficient use of small model C compilers. Because the lower 16-bit address of the FF bank and the lower 16-bit address of the 00 bank is the same, enabling reference to tables in ROM without the “far” pointer declaration.

For example, in accessing address 00C000H it is actually the contents of ROM at FFC000H that are accessed. If the MS bit in the ROMM register is set to “0”, the ROM area in the FF bank will exceed 48 Kbytes and it is not possible to reflect the entire area in the image in the 00 bank. Therefore the image from FF4000H to FFFFFFFH is reflected in the 00 bank and the area from FF0000H to FF3FFFH can be seen in the FF bank only.

^{*2} : In MB90F489B, there is no access to F8 bank and FC bank on the single-chip mode or the internal-ROM external-bus mode.

^{*3} : Because installed-ROM area is larger than MB90V485B, MB90F489B should execute emulation in an area that is larger than 004000H by the emulation memory area setting on the tool side.

MB90480/485 Series

•MB90F489B

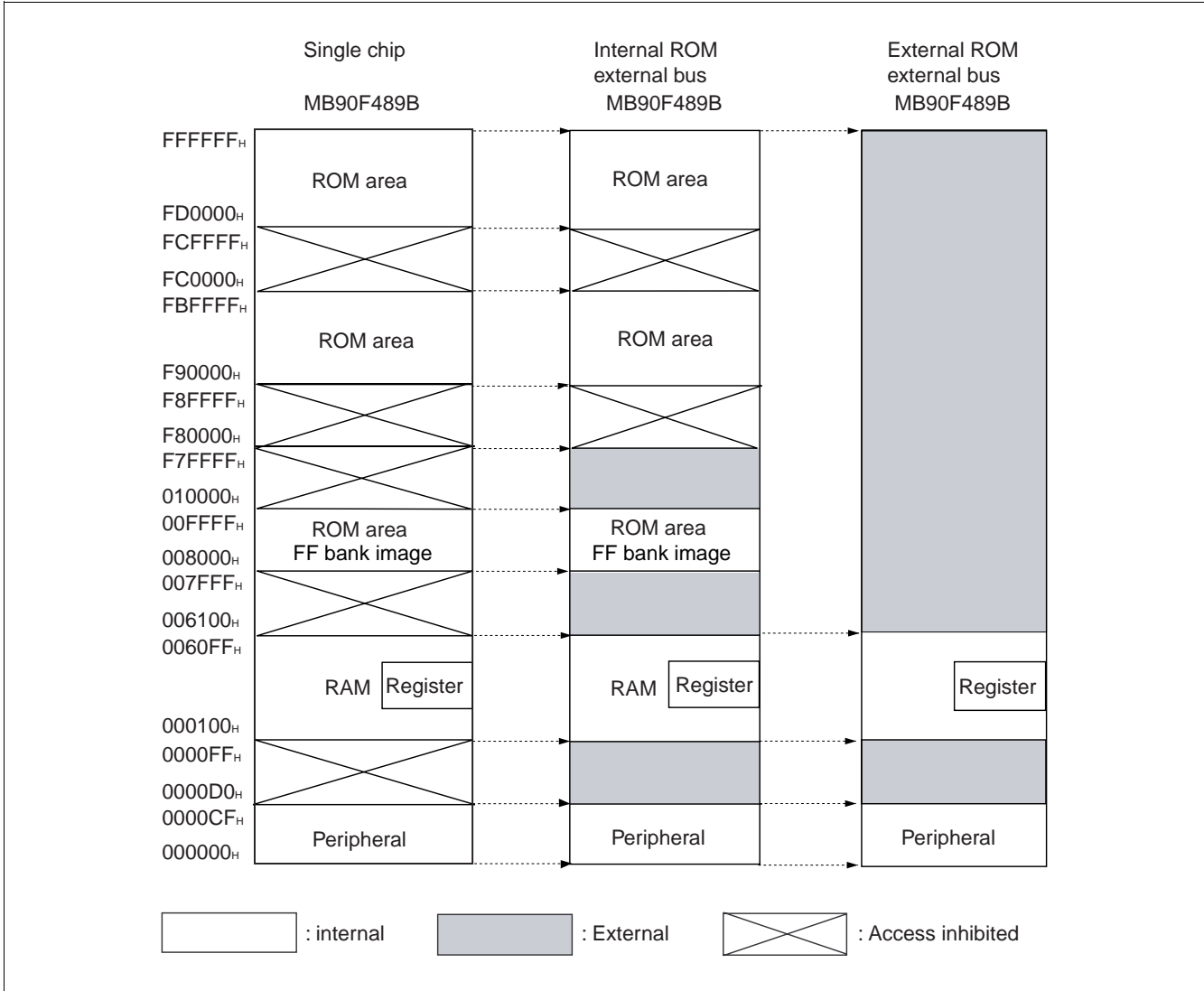

MB90480/485 Series

■ F²MC-16L CPU PROGRAMMING MODEL

•Dedicated registers

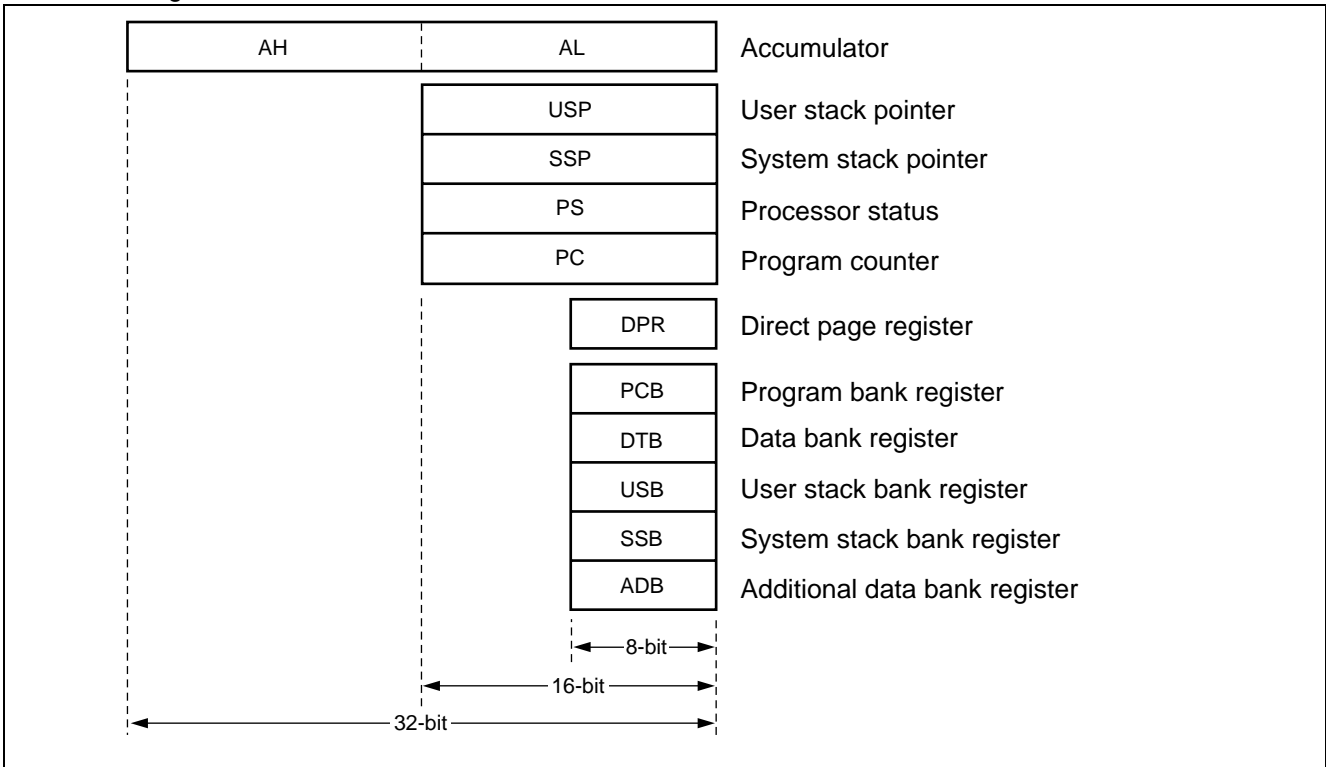

•General purpose registers

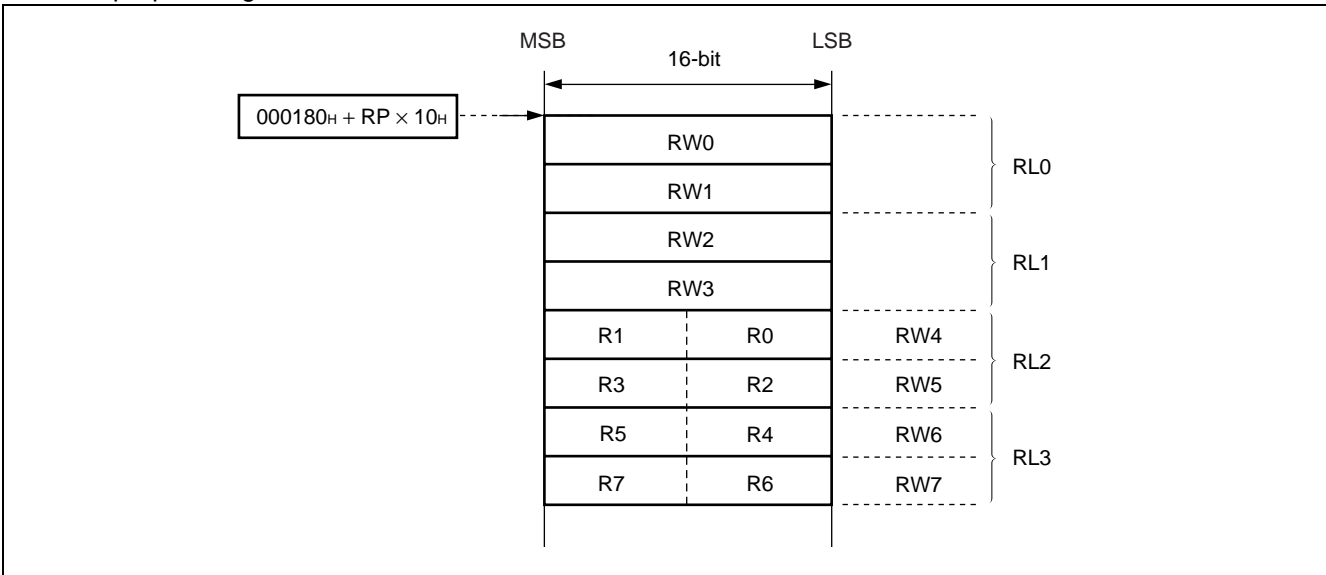

•Processor status

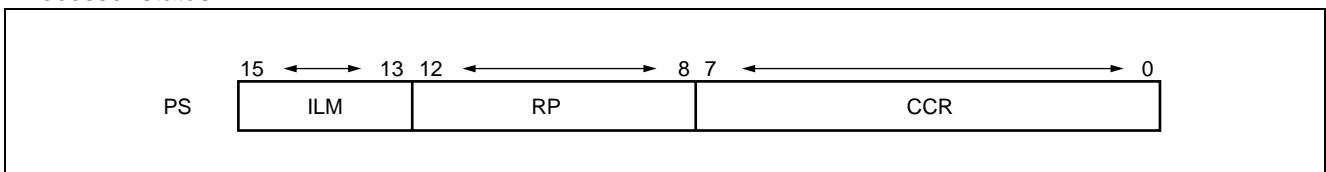

MB90480/485 Series

■ I/O MAP

Address	Register name	Abbreviated register name	Read/Write	Resource name	Initial value
00H	Port 0 data register	PDR0	R/W	Port 0	XXXXXXXX _B
01H	Port 1 data register	PDR1	R/W	Port 1	XXXXXXXX _B
02H	Port 2 data register	PDR2	R/W	Port 2	XXXXXXXX _B
03H	Port 3 data register	PDR3	R/W	Port 3	XXXXXXXX _B
04H	Port 4 data register	PDR4	R/W	Port 4	XXXXXXXX _B
05H	Port 5 data register	PDR5	R/W	Port 5	XXXXXXXX _B
06H	Port 6 data register	PDR6	R/W	Port 6	XXXXXXXX _B
07H	Port 7 data register	PDR7	R/W	Port 7	XXXXXXXX _B (MB90480 series) 11XXXXXXXX _B (MB90485 series)
08H	Port 8 data register	PDR8	R/W	Port 8	XXXXXXXX _B
09H	Port 9 data register	PDR9	R/W	Port 9	XXXXXXXX _B
0AH	Port A data register	PDRA	R/W	Port A	----XXXX _B
0BH	Up/down timer input enable register	UDRE	R/W	Up/down timer input control	XX000000 _B
0CH	Interrupt/DTP enable register	ENIR	R/W	DTP/external interrupts	00000000 _B
0DH	Interrupt/DTP source register	EIRR	R/W		XXXXXXXX _B
0EH	Request level setting register	ELVR	R/W		00000000 _B
0FH	Request level setting register		R/W		00000000 _B
10H	Port 0 direction register	DDR0	R/W	Port 0	00000000 _B
11H	Port 1 direction register	DDR1	R/W	Port 1	00000000 _B
12H	Port 2 direction register	DDR2	R/W	Port 2	00000000 _B
13H	Port 3 direction register	DDR3	R/W	Port 3	00000000 _B
14H	Port 4 direction register	DDR4	R/W	Port 4	00000000 _B
15H	Port 5 direction register	DDR5	R/W	Port 5	00000000 _B
16H	Port 6 direction register	DDR6	R/W	Port 6	00000000 _B
17H	Port 7 direction register	DDR7	R/W	Port 7	00000000 _B (MB90480 series) XX000000 _B (MB90485 series)
18H	Port 8 direction register	DDR8	R/W	Port 8	00000000 _B
19H	Port 9 direction register	DDR9	R/W	Port 9	00000000 _B
1AH	Port A direction register	DDRA	R/W	Port A	----0000 _B
1BH	Port 4 output pin register	ODR4	R/W	Port 4 (Open-drain control)	00000000 _B
1CH	Port 0 input resistance register	RDR0	R/W	Port 0 (resistance control)	00000000 _B
1DH	Port 1 input resistance register	RDR1	R/W	Port 1 (resistance control)	00000000 _B
1EH	Port 7 output pin register	ODR7	R/W	Port 7 (Open-drain control)	00000000 _B (MB90480 series) XX000000 _B (MB90485 series)
1FH	Analog input enable register	ADER	R/W	Port 6, A/D	11111111 _B

(Continued)

MB90480/485 Series

Address	Register name	Abbreviated register name	Read/Write	Resource name	Initial value
20 _H	Serial mode register	SMR	R/W	UART	0 0 0 0 X 0 0 _B
21 _H	Serial control register	SCR	R/W		0 0 0 0 0 1 0 0 _B
22 _H	Serial input/output register	SIDR/SODR	R/W		XXXXXXXX _B
23 _H	Serial status register	SSR	R/W		0 0 0 0 1 0 0 0 _B
24 _H	(Reserved area)				
25 _H	Communication prescaler control register	CDCR	R/W	Communication prescaler (UART)	0 0 - - 0 0 0 0 _B
26 _H	Serial mode control status register 0	SMCS0	R, R/W	SIO1 (ch0)	- - - - 0 0 0 0 _B
27 _H	Serial mode control status register 0	SMCS0	R, R/W		0 0 0 0 0 0 1 0 _B
28 _H	Serial data register 0	SDR0	R/W		XXXXXXXX _B
29 _H	Communication prescaler control register 0	SDCR0	R/W	Communication prescaler SIO1 (ch0)	0 - - - 0 0 0 0 _B
2A _H	Serial mode control status register 1	SMCS1	R, R/W	SIO2 (ch1)	- - - - 0 0 0 0 _B
2B _H	Serial mode control status register 1	SMCS1	R, R/W		0 0 0 0 0 0 1 0 _B
2C _H	Serial data register 1	SDR1	R/W		XXXXXXXX _B
2D _H	Communication prescaler control register 1	SDCR1	R/W	Communication prescaler SIO2 (ch1)	0 - - - 0 0 0 0 _B
2E _H	Reload register L (ch0)	PPLL0	R/W	8/16-bit PPG (ch0 to ch5)	XXXXXXXX _B
2F _H	Reload register H (ch0)	PPLH0	R/W		XXXXXXXX _B
30 _H	Reload register L (ch1)	PPLL1	R/W		XXXXXXXX _B
31 _H	Reload register H (ch1)	PPLH1	R/W		XXXXXXXX _B
32 _H	Reload register L (ch2)	PPLL2	R/W		XXXXXXXX _B
33 _H	Reload register H (ch2)	PPLH2	R/W		XXXXXXXX _B
34 _H	Reload register L (ch3)	PPLL3	R/W		XXXXXXXX _B
35 _H	Reload register H (ch3)	PPLH3	R/W		XXXXXXXX _B
36 _H	Reload register L (ch4)	PPLL4	R/W		XXXXXXXX _B
37 _H	Reload register H (ch4)	PPLH4	R/W		XXXXXXXX _B
38 _H	Reload register L (ch5)	PPLL5	R/W		XXXXXXXX _B
39 _H	Reload register H (ch5)	PPLH5	R/W		XXXXXXXX _B
3A _H	PPG0 operating mode control register	PPGC0	R/W		0 X 0 0 0 X X 1 _B
3B _H	PPG1 operating mode control register	PPGC1	R/W		0 X 0 0 0 0 0 1 _B
3C _H	PPG2 operating mode control register	PPGC2	R/W		0 X 0 0 0 X X 1 _B
3D _H	PPG3 operating mode control register	PPGC3	R/W		0 X 0 0 0 0 0 1 _B
3E _H	PPG4 operating mode control register	PPGC4	R/W	0 X 0 0 0 X X 1 _B	
3F _H	PPG5 operating mode control register	PPGC5	R/W	0 X 0 0 0 0 0 1 _B	
40 _H	PPG0, PPG1 output control register	PPG01	R/W	8/16-bit PPG	0 0 0 0 0 0 0 0 _B
41 _H	(Reserved area)				
42 _H	PPG2, PPG3 output control register	PPG23	R/W	8/16-bit PPG	0 0 0 0 0 0 0 0 _B
43 _H	(Reserved area)				

(Continued)

MB90480/485 Series

Address	Register name	Abbreviated register name	Read/Write	Resource name	Initial value
44H	PPG4, PPG5 output control register	PPG45	R/W	8/16-bit PPG	0 0 0 0 0 0 0 0 _B
45H	(Reserved area)				
46H	Control status register	ADCS1	R/W	A/Dconverter	0 0 0 0 0 0 0 0 _B
47H		ADCS2	W, R/W		0 0 0 0 0 0 0 0 _B
48H	Data register	ADCR1	R		XXXXXXXX _B
49H		ADCR2	W, R		0 0 0 0 0 XXX _B
4AH	Output compare register (ch0) lower digits	OCCP0	R/W	16-bit output timer output compare (ch0 to ch5)	0 0 0 0 0 0 0 0 _B
4BH	Output compare register (ch0) upper digits				0 0 0 0 0 0 0 0 _B
4CH	Output compare register (ch1) lower digits	OCCP1	R/W		0 0 0 0 0 0 0 0 _B
4DH	Output compare register (ch1) upper digits				0 0 0 0 0 0 0 0 _B
4EH	Output compare register (ch2) lower digits	OCCP2	R/W		0 0 0 0 0 0 0 0 _B
4FH	Output compare register (ch2) upper digits				0 0 0 0 0 0 0 0 _B
50H	Output compare register (ch3) lower digits	OCCP3	R/W		0 0 0 0 0 0 0 0 _B
51H	Output compare register (ch3) upper digits				0 0 0 0 0 0 0 0 _B
52H	Output compare register (ch4) lower digits	OCCP4	R/W		0 0 0 0 0 0 0 0 _B
53H	Output compare register (ch4) upper digits				0 0 0 0 0 0 0 0 _B
54H	Output compare register (ch5) lower digits	OCCP5	R/W		0 0 0 0 0 0 0 0 _B
55H	Output compare register (ch5) upper digits				0 0 0 0 0 0 0 0 _B
56H	Output compare control register (ch0, ch1) lower digits	OCS01	R/W		0 0 0 0 - - 0 0 _B
57H	Output compare control register (ch0, ch1) upper digits		R/W		- - - 0 0 0 0 0 0 _B
58H	Output compare control register (ch2, ch3) lower digits	OCS23	R/W		0 0 0 0 - - 0 0 _B
59H	Output compare control register (ch2, ch3) upper digits		R/W		- - - 0 0 0 0 0 0 _B
5AH	Output compare control register (ch4, ch5) lower digits	OCS45	R/W	0 0 0 0 - - 0 0 _B	
5BH	Output compare control register (ch4, ch5) upper digits		R/W	- - - 0 0 0 0 0 0 _B	
5CH	Input capture data register (ch0) lower digits	IPCP0	R	16-bit output timer input capture (ch0, ch1)	XXXXXXXX _B
5DH	Input capture data register (ch0) upper digits		R		XXXXXXXX _B
5EH	Input capture data register (ch1) lower digits	IPCP1	R		XXXXXXXX _B
5FH	Input capture data register (ch1) upper digits		R		XXXXXXXX _B
60H	Input capture control status register	ICS01	R/W	0 0 0 0 0 0 0 0 _B	
61H	(Reserved area)				

(Continued)

MB90480/485 Series

Address	Register name	Abbreviated register name	Read/Write	Resource name	Initial value
62H	Timer counter data register lower digits	TCDT	R/W	16-bit output timer free run timer	0 0 0 0 0 0 0 0 _B
63H	Timer counter data register upper digits	TCDT	R/W		0 0 0 0 0 0 0 0 _B
64H	Timer control status register	TCCS	R/W		0 0 0 0 0 0 0 0 _B
65H	Timer control status register	TCCS	R/W		0 - - 0 0 0 0 0 _B
66H	Compare clear register lower digits	CPCLR	R/W		XXXXXXXX _B
67H	Compare clear register upper digits				XXXXXXXX _B
68H	Up/down count register (ch0)	UDCR0	R	8/16-bit up/down timer counter	0 0 0 0 0 0 0 0 _B
69H	Up/down count register (ch1)	UDCR1	R		0 0 0 0 0 0 0 0 _B
6AH	Reload/compare register (ch0)	RCR0	W		0 0 0 0 0 0 0 0 _B
6BH	Reload/compare register (ch1)	RCR1	W		0 0 0 0 0 0 0 0 _B
6CH	Counter control register (ch0) lower digits	CCRL0	W, R/W		0 X 0 0 X 0 0 0 _B
6DH	Counter control register (ch0) upper digits	CCRH0	R/W		0 0 0 0 0 0 0 0 _B
6EH	(Reserved area)				
6FH	ROM mirror function select register	ROMM	R/W	ROM mirroring function	- - - - - +1 _B
70H	Counter control register (ch1) lower digits	CCRL1	W, R/W	8/16-bit up/down timer counter	0 X 0 0 X 0 0 0 _B
71H	Counter control register (ch1) upper digits	CCRH1	R/W		- 0 0 0 0 0 0 0 _B
72H	Counter status register (ch0)	CSR0	R, R/W		0 0 0 0 0 0 0 0 _B
73H	(Reserved area)				
74H	Counter status register (ch1)	CSR1	R, R/W	8/16-bit UDC	0 0 0 0 0 0 0 0 _B
75H	(Reserved area)				
76H*	PWC control/status register	PWCSR0	R, R/W	PWC timer (ch0)	0 0 0 0 0 0 0 0 _B
77H*					0 0 0 0 0 0 0 X _B
78H*	PWC data buffer register	PWCR0	R/W		0 0 0 0 0 0 0 0 _B
79H*					0 0 0 0 0 0 0 0 _B
7AH*	PWC control/status register	PWCSR1	R, R/W	PWC timer (ch 1)	0 0 0 0 0 0 0 0 _B
7BH*					0 0 0 0 0 0 0 X _B
7CH*	PWC data buffer register	PWCR1	R/W		0 0 0 0 0 0 0 0 _B
7DH*					0 0 0 0 0 0 0 0 _B
7EH*	PWC control/status register	PWCSR2	R, R/W	PWC timer (ch2)	0 0 0 0 0 0 0 0 _B
7FH*					0 0 0 0 0 0 0 X _B
80H*	PWC data buffer register	PWCR2	R/W		0 0 0 0 0 0 0 0 _B
81H*					0 0 0 0 0 0 0 0 _B
82H*	Dividing ratio control register	DIVR0	R/W	PWC (ch0)	- - - - - 0 0 _B
83H	(Reserved area)				
84H*	Dividing ratio control register	DIVR1	R/W	PWC (ch1)	- - - - - 0 0 _B
85H	(Reserved area)				
86H*	Dividing ratio control register	DIVR2	R/W	PWC (ch2)	- - - - - 0 0 _B
87H	(Reserved area)				

(Continued)

MB90480/485 Series

Address	Register name	Abbreviated register name	Read/Write	Resource name	Initial value
88 _H *	Bus status register	IBSR	R	I ² C	0 0 0 0 0 0 0 0 _B
89 _H *	Bus control register	IBCR	R/W		0 0 0 0 0 0 0 0 _B
8A _H *	Clock control register	ICCR	R/W		- - 0 X X X X X _B
8B _H *	Address register	IADR	R/W		- X X X X X X X _B
8C _H *	Data register	IDAR	R/W		XXXXXXXX _B
8D _H	(Reserved area)				
8E _H *	μPG control status register	PGCSR	R/W	μPG	0 0 0 0 0 - - - _B
8F _H to 9B _H	(Disabled)				
9C _H	μDMAC status register	DSRL	R/W	μDMAC	0 0 0 0 0 0 0 0 _B
9D _H	μDMAC status register	DSRH	R/W	μDMAC	0 0 0 0 0 0 0 0 _B
9E _H	Program address detection control status register	PACSR	R/W	Address match detection function	0 0 0 0 0 0 0 0 _B
9F _H	Delayed interrupt source general/cancel register	DIRR	R/W	Delayed interrupt generator module	- - - - - 0 _B
A0 _H	Low-power consumption mode control register	LPMCR	W, R/W	Low-power operation	0 0 0 1 1 0 0 0 _B
A1 _H	Clock select register	CKSCR	R, R/W	Low-power operation	1 1 1 1 1 1 0 0 _B
A2 _H , A3 _H	(Reserved area)				
A4 _H	μDMAC stop status register	DSSR	R/W	μDMAC	0 0 0 0 0 0 0 0 _B
A5 _H	Automatic ready function select register	ARSR	W	External pins	0 0 1 1 - - 0 0 _B
A6 _H	External address output control register	HACR	W	External pins	* * * * * _B
A7 _H	Bus control signal select register	EPCR	W	External pins	1 0 0 0 * 1 0 - _B
A8 _H	Watchdog timer control register	WDTC	R, W	Watchdog timer	XXXXX 1 1 1 _B
A9 _H	Timebase timer control register	TBTC	W, R/W	Timebase timer	1 X X 0 0 1 0 0 _B
AA _H	Watch timer control register	WTC	R, R/W	Watch timer	1 0 0 0 1 0 0 0 _B
AB _H	(Reserved area)				
AC _H	μDMAC enable area	DERL	R/W	μDMAC	0 0 0 0 0 0 0 0 _B
AD _H	μDMAC enable area	DERH	R/W	μDMAC	0 0 0 0 0 0 0 0 _B
AE _H	Flash memory control status register	FMCS	W, R/W	Flash memory interface	0 0 0 X 0 0 0 0 _B
AF _H	(Disabled)				
B0 _H	Interrupt control register 00	ICR00	W, R/W	—	X X X X 0 1 1 1 _B
B1 _H	Interrupt control register 01	ICR01	W, R/W	—	X X X X 0 1 1 1 _B
B2 _H	Interrupt control register 02	ICR02	W, R/W	—	X X X X 0 1 1 1 _B
B3 _H	Interrupt control register 03	ICR03	W, R/W	—	X X X X 0 1 1 1 _B
B4 _H	Interrupt control register 04	ICR04	W, R/W	—	X X X X 0 1 1 1 _B
B5 _H	Interrupt control register 05	ICR05	W, R/W	—	X X X X 0 1 1 1 _B
B6 _H	Interrupt control register 06	ICR06	W, R/W	—	X X X X 0 1 1 1 _B
B7 _H	Interrupt control register 07	ICR07	W, R/W	—	X X X X 0 1 1 1 _B
B8 _H	Interrupt control register 08	ICR08	W, R/W	—	X X X X 0 1 1 1 _B

(Continued)

MB90480/485 Series

Address	Register name	Abbreviated register name	Read/Write	Resource name	Initial value
B9 _H	Interrupt control register 09	ICR09	W, R/ W	—	XXXX0111 _B
BA _H	Interrupt control register 10	ICR10	W, R/ W	—	XXXX0111 _B
BB _H	Interrupt control register 11	ICR11	W, R/ W	—	XXXX0111 _B
BC _H	Interrupt control register 12	ICR12	W, R/ W	—	XXXX0111 _B
BD _H	Interrupt control register 13	ICR13	W, R/ W	—	XXXX0111 _B
BE _H	Interrupt control register 14	ICR14	W, R/ W	—	XXXX0111 _B
BF _H	Interrupt control register 15	ICR15	W, R/ W	—	XXXX0111 _B
C0 _H	Chip select area mask register 0	CMR0	R/W	Chip select function	00001111 _B
C1 _H	Chip select area register 0	CAR0	R/W	—	11111111 _B
C2 _H	Chip select area mask register 1	CMR1	R/W	—	00001111 _B
C3 _H	Chip select area register 1	CAR1	R/W	—	11111111 _B
C4 _H	Chip select area mask register 2	CMR2	R/W	—	00001111 _B
C5 _H	Chip select area register 2	CAR2	R/W	—	11111111 _B
C6 _H	Chip select area mask register 3	CMR3	R/W	—	00001111 _B
C7 _H	Chip select area register 3	CAR3	R/W	—	11111111 _B
C8 _H	Chip select control register	CSCR	R/W	—	----000* _B
C9 _H	Chip select active level register	CALR	R/W	—	----0000 _B
CA _H	Timer control status register	TMCSR	R/W	16-bit reload timer	00000000 _B
CB _H					----0000 _B
CC _H	16-bit timer register/ 16-bit reload register	TMR/TMLR	R/W		
CD _H					
CE _H	(Reserved area)				
CF _H	PLL output control register	PLLOS	W	Low-power operation	-----X0 _B
D0 _H to FF _H	(External area)				
100 _H to # _H	(RAM area)				
1FF0 _H	Program address detection resister 0 (Low order address)	PADR0	R/W	Address match detection function	XXXXXXXX _B
1FF1 _H	Program address detection resister 0 (Middle order address)				
1FF2 _H	Program address detection resister 0 (High order address)				

(Continued)

(Continued)

Address	Register name	Abbreviated register name	Read/Write	Resource name	Initial value
1FF3H	Program address detection resister 1 (Low order address)	PADR1	R/W	Address match detection function	XXXXXXXX _B
1FF4H	Program address detection resister 1 (Middle order address)				
1FF5H	Program address detection resister 1 (High order address)				

* : These registers are only for MB90485 series.
They are used as the reserved area on MB90480 series.

Descriptions for read/write

R/W : Readable and writable

R : Read only

W : Write only

Descriptions for initial value

0 : The initila value of this bit is "0".

1 : The initial value of this bit is "1".

X : The initial value of this bit is undefined.

- : This bit is not used.

* : The initial value of this bit is "1" or "0".

The value depends on the mode pin (MD2, MD1 and MD0) .

+ : The initial value of this bit is "1" or "0".

The value depends on the RAM area of device.

MB90480/485 Series

■ INTERRUPT SOURCES, INTERRUPT VECTORS, AND INTERRUPT CONTROL REGISTERS

Interrupt source	Clear of EI ² OS	μDMAC channel number	Interrupt vector		Interrupt control register	
			Number	Address	Number	Address
Reset	×	—	#08	FFFFDC _H	—	—
INT9 instruction	×	—	#09	FFFFD8 _H	—	—
Exception	×	—	#10	FFFFD4 _H	—	—
INT0 (IRQ0)	○	0	#11	FFFFD0 _H	ICR00	0000B0 _H
INT1 (IRQ1)	○	×	#12	FFFFCC _H		
INT2 (IRQ2)	○	×	#13	FFFFC8 _H	ICR01	0000B1 _H
INT3 (IRQ3)	○	×	#14	FFFFC4 _H		
INT4 (IRQ4)	○	×	#15	FFFFC0 _H	ICR02	0000B2 _H
INT5 (IRQ5)	○	×	#16	FFFFBC _H		
INT6 (IRQ6)	○	×	#17	FFFFB8 _H	ICR03	0000B3 _H
INT7 (IRQ7)	○	×	#18	FFFFB4 _H		
PWC1 (MB90485 series only)	○	×	#19	FFFFB0 _H	ICR04	0000B4 _H
PWC2 (MB90485 series only)	○	×	#20	FFFFAC _H		
PWC0 (MB90485 series only)	○	1	#21	FFFFA8 _H	ICR05	0000B5 _H
PPG0/PPG1 counter borrow	×	×	#22	FFFFA4 _H		
PPG2/PPG3 counter borrow	×	×	#23	FFFFA0 _H	ICR06	0000B6 _H
PPG4/PPG5 counter borrow	×	×	#24	FFFF9C _H		
8/16-bit up/down counter/ timer (ch0, 1) compare/ underflow/overflow/inversion	○	×	#25	FFFF98 _H	ICR07	0000B7 _H
Input capture (ch0) load	○	5	#26	FFFF94 _H		
Input capture (ch1) load	○	6	#27	FFFF90 _H	ICR08	0000B8 _H
Output compare (ch0) match	○	8	#28	FFFF8C _H		
Output compare (ch1) match	○	9	#29	FFFF88 _H	ICR09	0000B9 _H
Output compare (ch2) match	○	10	#30	FFFF84 _H		
Output compare (ch3) match	○	×	#31	FFFF80 _H	ICR10	0000BA _H
Output compare (ch4) match	○	×	#32	FFFF7C _H		
Output compare (ch5) match	○	×	#33	FFFF78 _H	ICR11	0000BB _H
UART sending completed	○	11	#34	FFFF74 _H		
16-bit free run timer overflow, 16-bit reload timer underflow*2	○	12	#35	FFFF70 _H	ICR12	0000BC _H
UART receiving completed	◎	7	#36	FFFF6C _H		
SIO1 (ch0)	○	13	#37	FFFF68 _H	ICR13	0000BD _H
SIO2 (ch1)	○	14	#38	FFFF64 _H		

(Continued)

(Continued)

Interrupt source	Clear of EI ² OS	μDMAC channel number	Interrupt vector		Interrupt control register	
			Number	Address	Number	Address
I ² C interface (MB90485 series only)	×	×	#39	FFFF60 _H	ICR14	0000BE _H
A/D conversion	○	15	#40	FFFF5C _H		
FLASH write/erase, timebase timer, watch timer *1	×	×	#41	FFFF58 _H	ICR15	0000BF _H
Delay interrupt generator module	×	×	#42	FFFF54 _H		

× : Interrupt request flag is not cleared by the interrupt clear signal.

○ : Interrupt request flag is cleared by the interrupt clear signal.

◎ : Interrupt request flag is cleared by the interrupt clear signal (stop request present) .

*1 : Caution : The FLASH write/erase, timebase timer, and watch timer cannot be used at the same time.

*2 : When the 16-bit reload timer underflow interrupt is changed from enable (TMCSR : INTE = 1) to disable (TMCSR : INTE = 0) , disable the interrupt in the interrupt control register (ICR12 : IL2 to 0 : 111_B) , then set the INTE bit to 0.

Note : If there are two interrupt sources for the same interrupt number, the resource will clear both interrupt request flags at the EI²OS/μDMAC interrupt clear signal. Therefore if either of the two sources uses the EI²OS/μDMAC function, the other interrupt function cannot be used. The interrupt request enable bit for the corresponding resource should be set to "0" and interrupt requests from that resource should be handled by software polling.

MB90480/485 Series

■ PERIPHERAL RESOURCES

1. I/O Ports

The I/O ports perform the functions of either sending data from the CPU to the I/O pins, or loading information from the I/O into the CPU, according to the setting of the corresponding port register (PDR). The input/output direction of each I/O pin can be set in individual bit units by the port direction register (DDR) for each port. The MB90480/485 series has 84 input/output pins. The I/O ports are port 0 through port A.

(1) Port Data Registers

PDR0	7	6	5	4	3	2	1	0	Initial value	Access
Address : 000000H	P07	P06	P05	P04	P03	P02	P01	P00	Undefined	R/W*1
PDR1	7	6	5	4	3	2	1	0		
Address : 000001H	P17	P16	P15	P14	P13	P12	P11	P10	Undefined	R/W*1
PDR2	7	6	5	4	3	2	1	0		
Address : 000002H	P27	P26	P25	P24	P23	P22	P21	P20	Undefined	R/W*1
PDR3	7	6	5	4	3	2	1	0		
Address : 000003H	P37	P36	P35	P34	P33	P32	P31	P30	Undefined	R/W*1
PDR4	7	6	5	4	3	2	1	0		
Address : 000004H	P47	P46	P45	P44	P43	P42	P41	P40	Undefined	R/W*1
PDR5	7	6	5	4	3	2	1	0		
Address : 000005H	P57	P56	P55	P54	P53	P52	P51	P50	Undefined	R/W*1
PDR6	7	6	5	4	3	2	1	0		
Address : 000006H	P67	P66	P65	P64	P63	P62	P61	P60	Undefined	R/W*1
PDR7	7	6	5	4	3	2	1	0		
Address : 000007H	P77	P76	P75	P74	P73	P72	P71	P70	Undefined*2	R/W*1
PDR8	7	6	5	4	3	2	1	0		
Address : 000008H	P87	P86	P85	P84	P83	P82	P81	P80	Undefined	R/W*1
PDR9	7	6	5	4	3	2	1	0		
Address : 000009H	P97	P96	P95	P94	P93	P92	P91	P90	Undefined	R/W*1
PDRA	7	6	5	4	3	2	1	0		
Address : 00000AH	—	—	—	—	PA3	PA2	PA1	PA0	Undefined	R/W*1

*1 : The R/W indication for I/O ports is somewhat different than R/W access to memory, and involves the following operations.

- Input mode
 - Read : Reads the corresponding signal pin level.
 - Write : Writes to the output latch.
- Output mode
 - Read : Reads the value from the data register latch.
 - Write : Outputs the value to the corresponding signal pin.

*2 : The initial value of this bit is "11XXXXXX_B" on MB90485 series.

(2) Port Direction Registers

Register	7	6	5	4	3	2	1	0	Initial value	Access
DDR0 Address : 000010 _H	D07	D06	D05	D04	D03	D02	D01	D00	00000000 _B	R/W
DDR1 Address : 000011 _H	D17	D16	D15	D14	D13	D12	D11	D10	00000000 _B	R/W
DDR2 Address : 000012 _H	D27	D26	D25	D24	D23	D22	D21	D20	00000000 _B	R/W
DDR3 Address : 000013 _H	D37	D36	D35	D34	D33	D32	D31	D30	00000000 _B	R/W
DDR4 Address : 000014 _H	D47	D46	D45	D44	D43	D42	D41	D40	00000000 _B	R/W
DDR5 Address : 000015 _H	D57	D56	D55	D54	D53	D52	D51	D50	00000000 _B	R/W
DDR6 Address : 000016 _H	D67	D66	D65	D64	D63	D62	D61	D60	00000000 _B	R/W
DDR7 Address : 000017 _H	D77*1	D76*1	D75	D74	D73	D72	D71	D70	00000000 _B *2	R/W
DDR8 Address : 000018 _H	D87	D86	D85	D84	D83	D82	D81	D80	00000000 _B	R/W
DDR9 Address : 000019 _H	D97	D96	D95	D94	D93	D92	D91	D90	00000000 _B	R/W
DDRA Address : 00001A _H	—	—	—	—	DA3	DA2	DA1	DA0	---- 0000 _B	R/W

*1 : The value is set to “—” on MB90485 series only.

*2 : The initial value of this bit is “XX000000_B” on MB90485 series only.

- When a set of pins is functioning as a port, the corresponding signal pins are controlled as follows.
 - 0 : Input mode.
 - 1 : Output mode. Reset to “0”.

Notes : • When any of these register are accessed using a read-modify-write type instruction (such as a bit set instruction), the bit specified in the instruction will be set to the indicated value. However, the contents of output registers corresponding to any other bits having input settings will be rewritten to the input values of those pins at that time.

For this reason, when changing any pin that has been used for input to output, first write the desired value to the PDR register before setting the DDR register for output.

- P76, P77 (MB90485 series only)

This port has no DDR. To use P77, P76 and I²C pins, set the PDR value to “1” so that port data remains enabled (to use P77 and P76 for general purposes, disable I²C). The port is an open drain output (with no Pch).

To use it as an input port, therefore, set the PDR to “1” to turn off the output transistor and add a pull-up resistor to the external output.

MB90480/485 Series

(3) Port Input Resistance Registers

RDR0	7	6	5	4	3	2	1	0	Initial value	Access
Address : 00001C _H	RD07	RD06	RD05	RD04	RD03	RD02	RD01	RD00	00000000 _B	R/W
RDR1	7	6	5	4	3	2	1	0		
Address : 00001D _H	RD17	RD16	RD15	RD14	RD13	RD12	RD11	RD10	00000000 _B	R/W

These registers control the use of pull-up resistance in input mode.

- 0 : No pull-up resistance in input mode.
- 1 : With pull-up resistance in input mode.

In output mode, these registers have no significance (no pull-up resistance) . Input/output mode settings are controlled by the port direction (DDR) registers.

In case of a stop (SPL = 1) , no pull-up resistance is applied (high impedance) . This function is prohibited when an external bus is used. Do not write to these registers.

(4) Port Output Pin Registers

ODR7	7	6	5	4	3	2	1	0	Initial value	Access
Address : 00001E _H	OD77*1	OD76*1	OD75	OD74	OD73	OD72	OD71	OD70	00000000 _B *2	R/W
ODR4	7	6	5	4	3	2	1	0		
Address : 00001B _H	OD47	OD46	OD45	OD44	OD43	OD42	OD41	OD40	00000000 _B	R/W

*1 : The value is set to “—” on MB90485 series only.

*2 : The initial value of this bit is “XX000000_B” on MB90485 series only.

These registers control open drain settings in output mode.

- 0 : Standard output port functions in output mode.
- 1 : Open drain output port in output mode.

In input mode these registers have no significance (Hi-Z output) . Input/output mode settings are controlled by direction (DDR) registers. This function is prohibited when an external bus is used. Do not write to these registers.

(5) Analog Input Enable Register

ADER	7	6	5	4	3	2	1	0	Initial value	Access
Address : 00001F _H	ADE7	ADE6	ADE5	ADE4	ADE3	ADE2	ADE1	ADE0	11111111 _B	R/W

This register controls the port 6 pins as follows.

- 0 : Port input/output mode.
- 1 : Analog input mode. The default value at reset is all “1”.

(6) Up-down Timer Input Enable Register

UDER	7	6	5	4	3	2	1	0	Initial value	Access
Address : 00000B _H	—	—	UDE5	UDE4	UDE3	UDE2	UDE1	UDE0	XX000000 _B	R/W

This register controls the port 3 pins as follows.

- 0 : Port input mode.
- 1 : Up/down timer input mode. The default value at reset is “0”.

The MB90480/485 series uses the following setting values : UDE0 : P30/AIN0, UDE1 : P31/BIN0/UDE2 : P32/ZIN0,
UDE3 : P33/AIN1, UDE4 : P34/BIN1, UDE5 : P35/ZIN1

2. UART

The UART is a serial I/O port for asynchronous (start-stop synchronized) communication as well as CLK synchronized communication.

- Full duplex double buffer
- Transfer modes : asynchronous (start-stop synchronized) , or CLK synchronized (no start bit or stop bit) .
- Multi-processor mode supported.
- Embedded proprietary baud rate generator
 - Asynchronous : 76923/38461/19230/9615/500 K/250 Kbps
 - CLK synchronized : 16 M/8 M/4 M/2 M/1 M/500 Kbps
- External clock setting available, allows use of any desired baud rate.
- Can use internal clock feed from PPG1.
- Data length : 7-bit (asynchronous normal mode only) or 8-bit.
- Master/slave type communication functions (in multi-processor mode) .
- Error detection functions (parity, framing, overrun)
- Transmission signals are NRZ encoded.
- μ DMAC supported (for receiving/sending)

MB90480/485 Series

(1) Register List

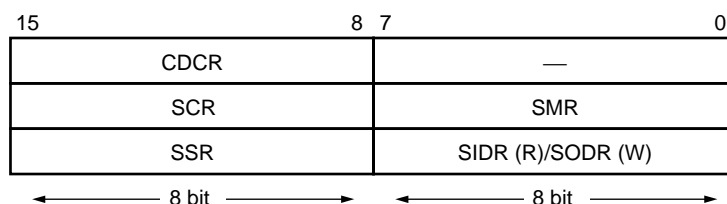

Serial mode register (SMR)

	7	6	5	4	3	2	1	0	
000020H	MD1	MD0	CS2	CS1	CS0	Reserved	SCKE	SOE	
	R/W	R/W	R/W	R/W	R/W	R/W	R/W	R/W	Initial value
	0	0	0	0	0	X	0	0	

Serial control register (SCR)

	15	14	13	12	11	10	9	8	
000021H	PEN	P	SBL	CL	A/D	REC	RXE	TXE	
	R/W	R/W	R/W	R/W	R/W	W	R/W	R/W	Initial value
	0	0	0	0	0	1	0	0	

Serial I/O register (SIDR/SODR)

	7	6	5	4	3	2	1	0	
000022H	D7	D6	D5	D4	D3	D2	D1	D0	
	R/W	R/W	R/W	R/W	R/W	R/W	R/W	R/W	Initial value
	X	X	X	X	X	X	X	X	

Serial data register (SSR)

	15	14	13	12	11	10	9	8	
000023H	PE	ORE	FRE	RDRF	TDRE	BDS	RIE	TIE	
	R	R	R	R	R	R/W	R/W	R/W	Initial value
	0	0	0	0	1	0	0	0	

Communication prescaler control register (CDCR)

	15	14	13	12	11	10	9	8	
000025H	MD	SRST	—	—	DIV3	DIV2	DIV1	DIV0	
	R/W	R/W	—	—	R/W	R/W	R/W	R/W	Initial value
	0	0	—	—	0	0	0	0	

(2) Block Diagram

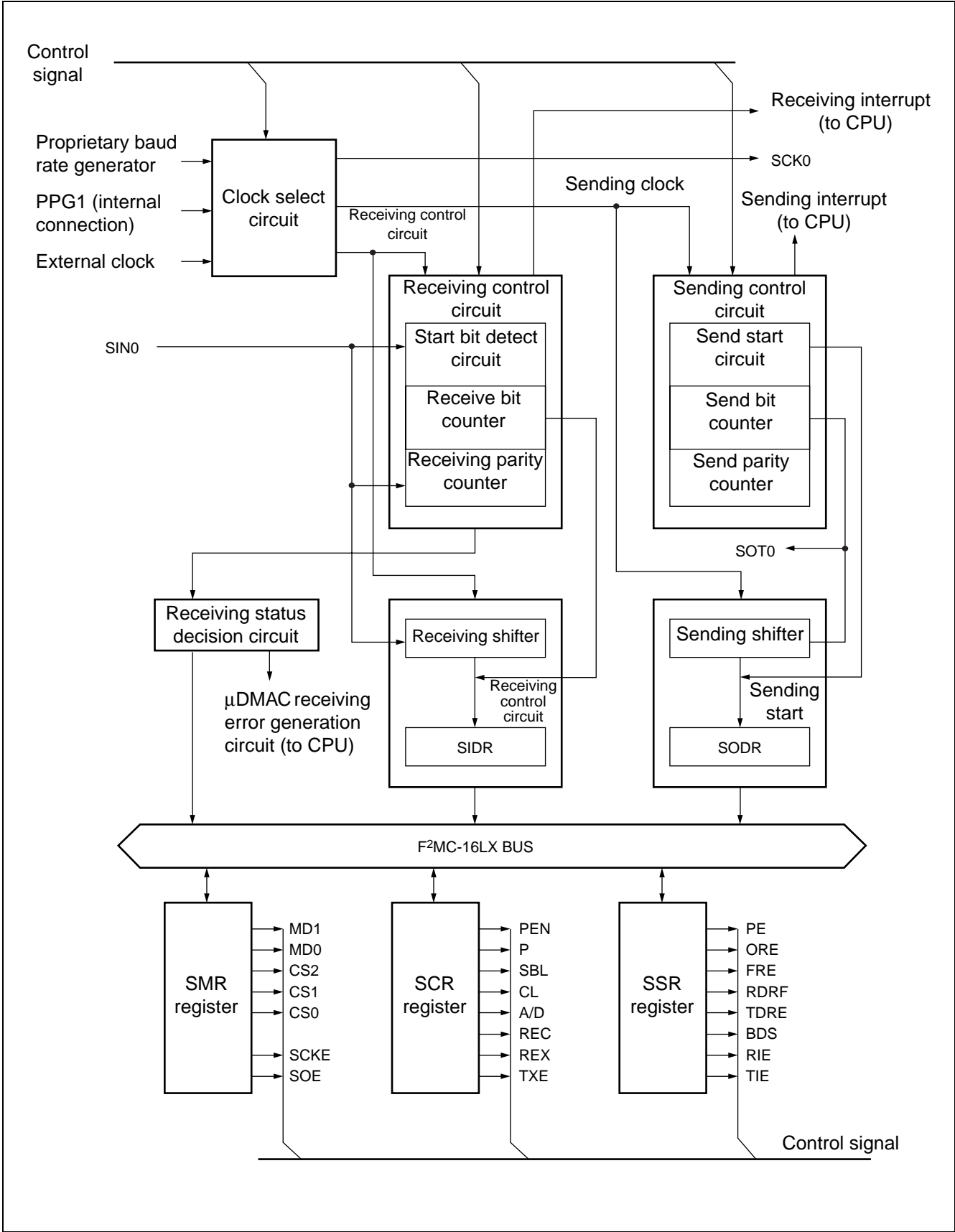

MB90480/485 Series

3. Expanded I/O Serial Interface

The expanded I/O serial interface is an 8-bit × 1-channel serial I/O interface for clock synchronized data transmission. A selection of LSB-first or MSB-first data transmission is provided.

There are two serial I/O operation modes.

- Internal shift clock mode : Data transmission is synchronized with the internal clock signal.
- External shift clock mode : Data transmission is synchronized with a clock signal input from the external clock signal pin (SCK). In this mode the general-purpose port that shares the external clock signal pin (SCK) can be used for transmission according to CPU instructions.

(1) Register List

Serial mode control status register 0/1 (SMCS0, SMCS1)								Initial value	
Address : 000027H 00002BH	15	14	13	12	11	10	9	8	00000010 _B
	SMD2	SMD1	SMD0	SIE	SIR	BUSY	STOP	STRT	
	R/W	R/W	R/W	R/W	R/W	R	R/W	R/W	
Address : 000026H 00002AH	7	6	5	4	3	2	1	0	----0000 _B
	—	—	—	—	MODE	BDS	SOE	SCOE	
					R/W	R/W	R/W	R/W	
Serial data register 0/1 (SDR0, SDR1)									
Address : 000028H 00002CH	7	6	5	4	3	2	1	0	XXXXXXXX _B
	D7	D6	D5	D4	D3	D2	D1	D0	
	R/W	R/W	R/W	R/W	R/W	R/W	R/W	R/W	
Communication prescaler control register 0/1 (SDCR0, SDCR1)									
Address : 000029H 00002DH	15	14	13	12	11	10	9	8	0---0000 _B
	MD	—	—	—	DIV3	DIV2	DIV1	DIV0	
	R/W	—	—	—	R/W	R/W	R/W	R/W	

(2) Block Diagram

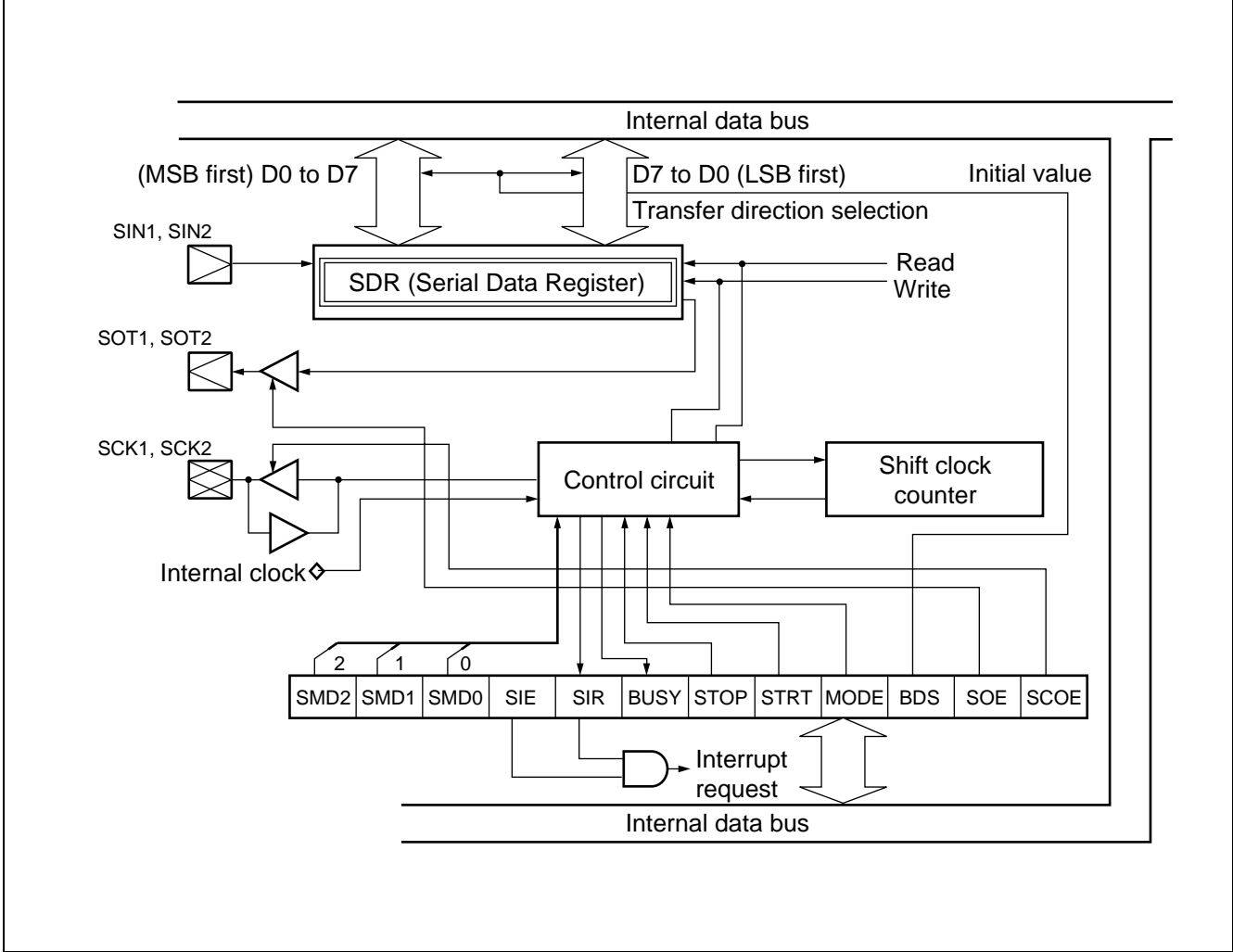

MB90480/485 Series

4. 8/10-bit A/D Converter

The A/D converter converts analog input voltage input voltages to digital values, and provides the following features.

- Conversion time : minimum 3.68 μ s per channel
(92 machine cycles at 25 MHz machine clock, including sampling time)
- Sampling time : minimum 1.92 μ s per channel
(48 machine cycles at 25 MHz machine clock)
- RC sequential comparison conversion method, with sample & hold circuit.
- 8-bit or 10-bit resolution
- Analog input selection of 8 channels

Single conversion mode : Conversion from one selected channel.

Scan conversion mode : Conversion from multiple consecutive channels, programmable selection of up to 8 channels.

Continuous conversion mode : Repeated conversion of specified channels.

Stop conversion mode : Conversion from one channel followed by a pause until the next activation.

- At the end of A/D conversion, an A/D conversion completed interrupt request can be generated. The interrupt can be used activate the μ DMAC in order to transfer the results of A/D conversion to memory for efficient continuous processing.
- The starting factor conversion may be selected from software, external trigger (falling edge) , or timer (rising edge) .

(1) Register List

ADCS2, ADCS1 (Control status register)									
ADCS1									
Address : 000046 _H	7	6	5	4	3	2	1	0	
	MD1	MD0	ANS2	ANS1	ANS0	ANE2	ANE1	ANE0	
	0	0	0	0	0	0	0	0	←Initial value
	R/W	R/W	R/W	R/W	R/W	R/W	R/W	R/W	←Bit attributes
ADCS2									
Address : 000047 _H	15	14	13	12	11	10	9	8	
	BUSY	INT	INTE	PAUS	STS1	STS0	STRT	Reserved	
	0	0	0	0	0	0	0	0	←Initial value
	R/W	R/W	R/W	R/W	R/W	R/W	W	R/W	←Bit attributes
ADCR2, ADCR1 (Data register)									
ADCR1									
Address : 000048 _H	7	6	5	4	3	2	1	0	
	D7	D6	D5	D4	D3	D2	D1	D0	
	X	X	X	X	X	X	X	X	←Initial value
	R	R	R	R	R	R	R	R	←Bit attributes
ADCR2									
Address : 000049 _H	15	14	13	12	11	10	9	8	
	S10	ST1	ST0	CT1	CT0	—	D9	D8	
	0	0	0	0	0	X	X	X	←Initial value
	R/W	W	W	W	W	R	R	R	←Bit attributes

(2) Block Diagram

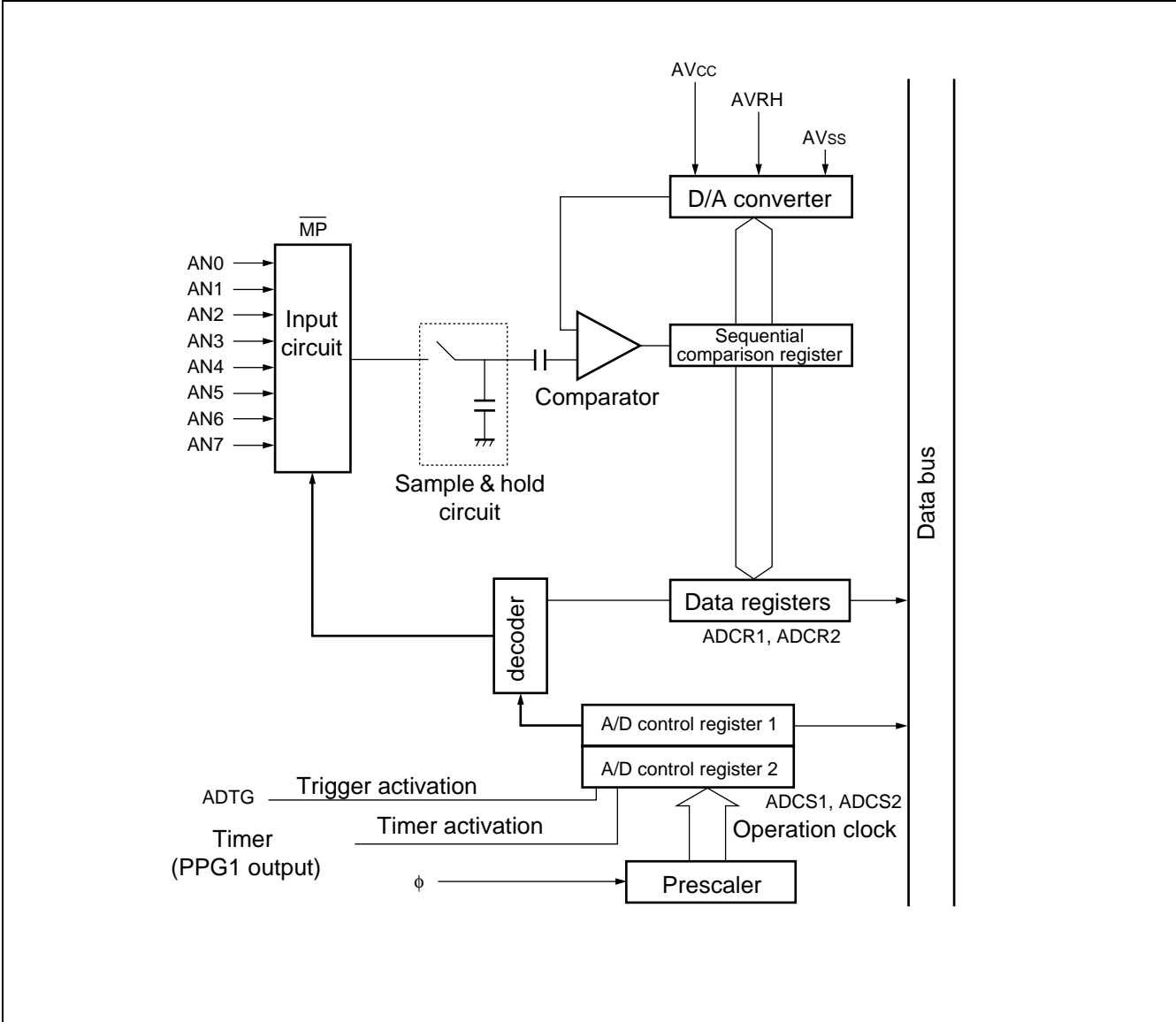

MB90480/485 Series

5. 8/16-bit PPG

The 8/16-bit PPG is an 8-bit reload timer module that produces a PPG output using a pulse from the timer operation. Hardware resources include 6 × 8-bit down counters, 12 × 8-bit reload timers, 3 × 16-bit control registers, 6 external bus output pins, and 6 interrupt outputs. Note that MB90480/485 series has six channels for 8-bit PPG use, which can also be combined as PPG0 + PPG1, PPG2 + PPG3, and PPG4 + PPG5 to operate as a three-channel 16-bit PPG. The following is a summary of functions.

- 8-bit PPG output 6-channel independent mode : Provides PPG output operation on six independent channels.
- 16-bit PPG output operation mode : Provides 16-bit PPG output on three channels. The six original channels are used in combination as PPG0 + PPG1, PPG2 + PPG3, and PPG4 + PPG5.
- 8 + 8-bit PPG operation mode : Output from PPG0 (PPG2/PPG4) is used as clock input to PPG1 (PPG3/PPG5) to provide to 8-bit PPG output at any desired period length.
- PPG output operation : Produces pulse waves at any desired period and duty ratio. The PPG module can also be used with external circuits as a D/A converter.

(1) Register List

PPGC0/PPGC2/PPGC4 (PPG0/PPG2/PPG4 operation mode control register)

	7	6	5	4	3	2	1	0	
00003AH	PEN0	—	PE00	PIE0	PUF0	—	—	Reserved	
00003CH									
00003EH	R/W	—	R/W	R/W	R/W	—	—	—	Read/write
	0	X	0	0	0	X	X	1	Initial value

PPGC1/PPGC3/PPGC5 (PPG1/PPG3/PPG5 operation mode control register)

	15	14	13	12	11	10	9	8	
00003BH	PEN1	—	PE10	PIE1	PUF1	MD1	MD0	Reserved	
00003DH									
00003FH	R/W	—	R/W	R/W	R/W	R/W	R/W	—	Read/write
	0	X	0	0	0	0	0	1	Initial value

PPG01/PPG23/PPG45 (PPG0 to PPG5 output control register)

	7	6	5	4	3	2	1	0	
000040H	PCS2	PCS1	PCS0	PCM2	PCM1	PCM0	Reserved	Reserved	
000042H									
000044H	R/W	R/W	R/W	R/W	R/W	R/W	R/W	R/W	Read/write
	0	0	0	0	0	0	0	0	Initial value

PPLL0 to PPLL5 (Reload register L)

	7	6	5	4	3	2	1	0	
00002EH	D07	D06	D05	D04	D03	D02	D01	D00	
000030H									
000032H									
000034H	R/W	R/W	R/W	R/W	R/W	R/W	R/W	R/W	Read/write
000036H	X	X	X	X	X	X	X	X	Initial value
000038H									

PPLH0 to PPLH5 (Reload register H)

	15	14	13	12	11	10	9	8	
00002FH	D15	D14	D13	D12	D11	D10	D09	D08	
000031H									
000033H									
000035H	R/W	R/W	R/W	R/W	R/W	R/W	R/W	R/W	Read/write
000037H	X	X	X	X	X	X	X	X	Initial value
000039H									

(2) Block Diagram

•8-bit PPG channel 0/2/4 block Diagram

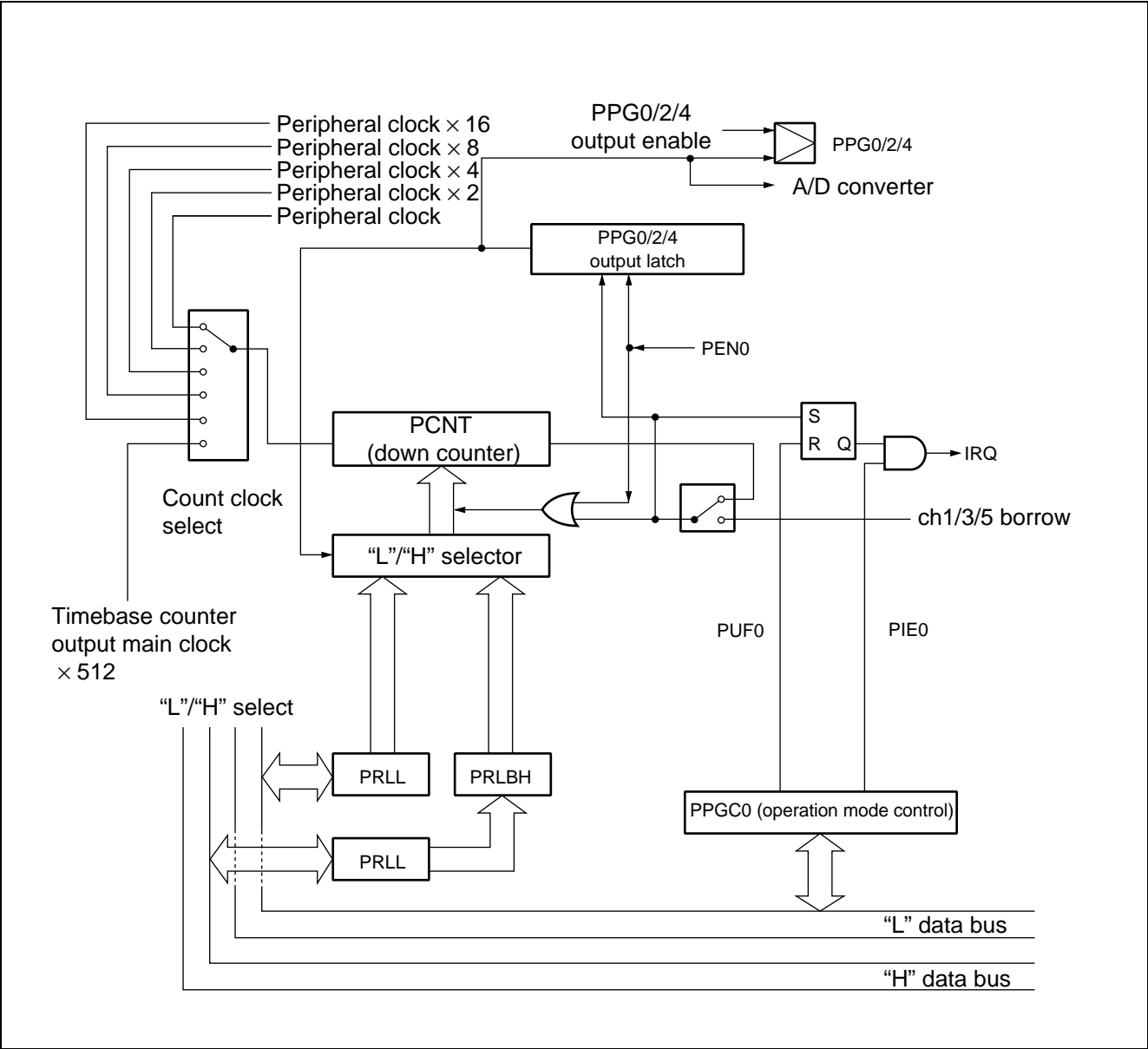

MB90480/485 Series

• 8-bit PPG ch1/3/5 Block Diagram

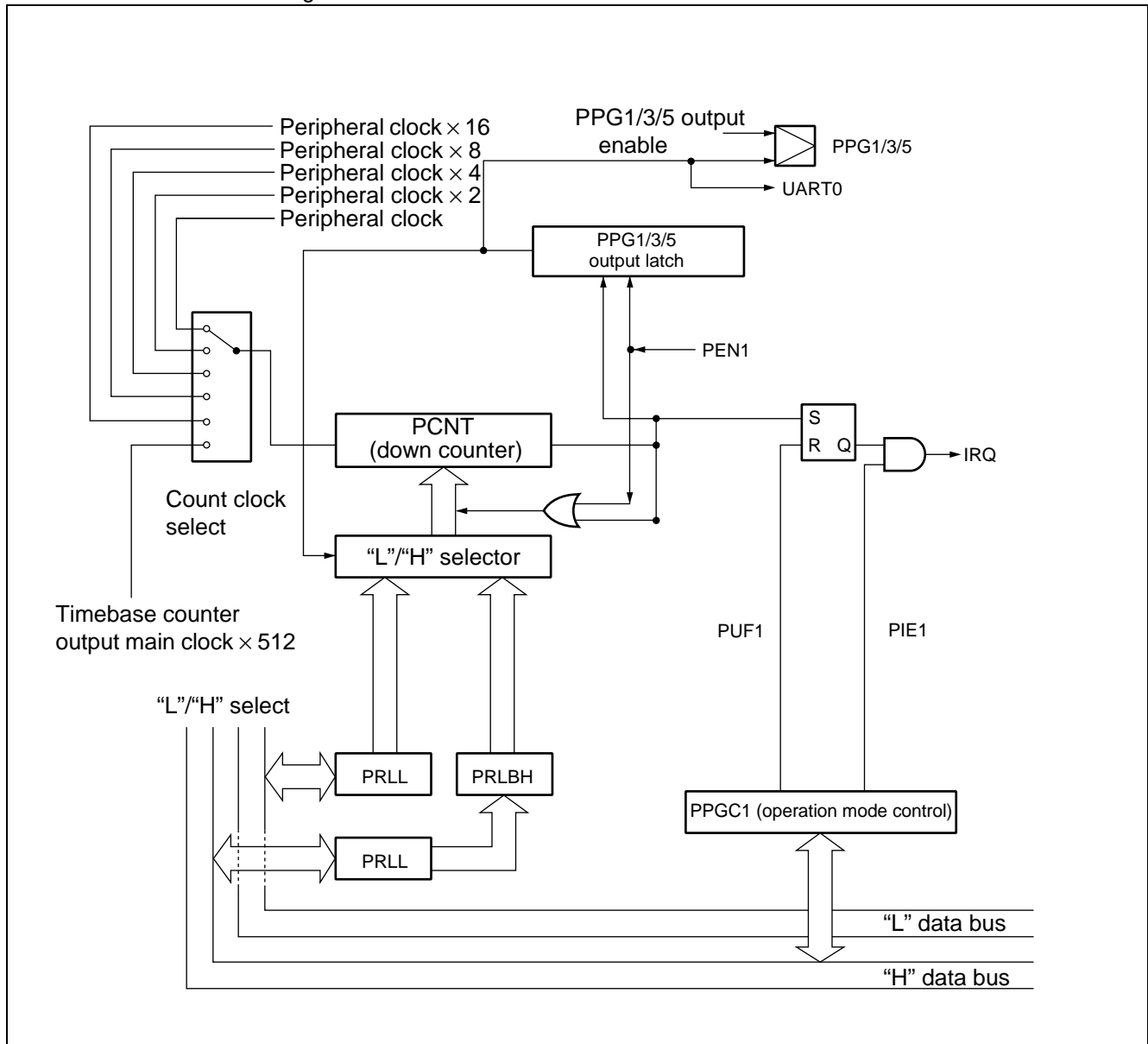

6. 8/16-bit up/down Counter/Timer

8/16-bit up/down counter/timer consists of up/down counter/timer circuits including six event input pins, two 8-bit up/down counters, two 8-bit reload/compare registers, as well as the related control circuits.

(1) Principal Functions

- 8-bit count register enables counting in the range 0 to 256.
(In 16-bit \times 1 mode, counting is enabled in the range 0 to 65535)
- Count clock selection provides four count modes.

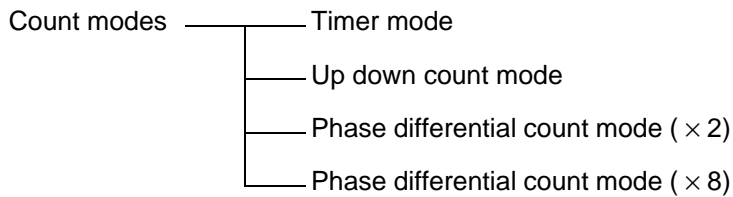

- In timer mode, there is a choice of two internal count clock signals.

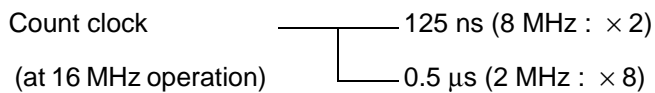

- In up/down count mode there is a choice of trigger edge detection for the input signal from external pins.

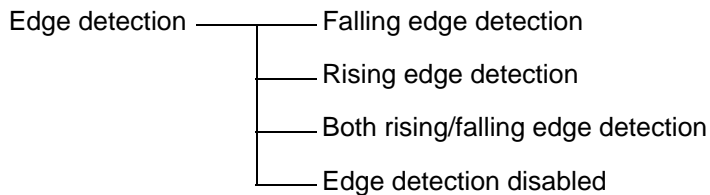

- In phase differential count mode, to handle encoder counting for mortors, the encode A-phase, B-phase, and Z-phase are each input, enabling easy and highly accurate counting of angle of rotation, speed of rotation, etc.
- The ZIN pin provides a selection of two functions

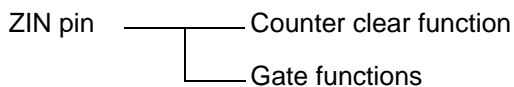

- A compare function and reload function are provided, each for use separately or in combination. Both functions can be activated together for up/down counting in any desired bandwidth.

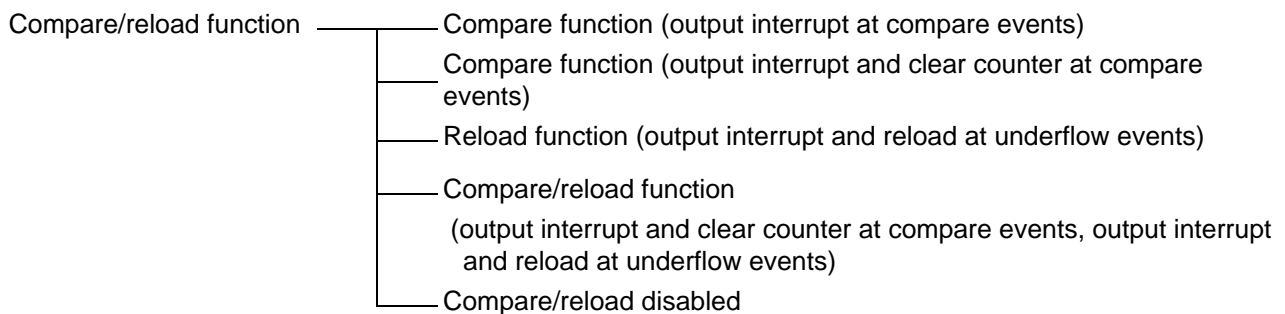

- Individual control over interrupts at compare, reload (underflow) and overflow events.
- Count direction flag enables identification of the last previous count direction.
- Interrupt generated when count direction changes.

MB90480/485 Series

(2) Register List

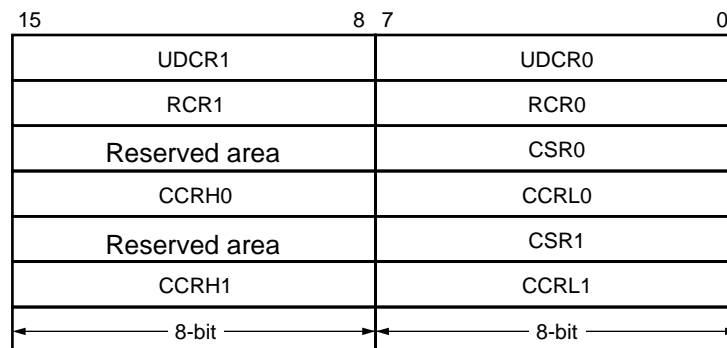

CCRH0 (Counter Control Register High ch0)

Address : 00006D _H	15	14	13	12	11	10	9	8	Initial value
	M16E	CDCF	CFIE	CLKS	CMS1	CMS0	CES1	CES0	0000000 _B
	R/W	R/W	R/W	R/W	R/W	R/W	R/W	R/W	

CCRH1 (Counter Control Register High ch1)

Address : 000071 _H	15	14	13	12	11	10	9	8	Initial value
	—	CDCF	CFIE	CLKS	CMS1	CMS0	CES1	CES0	-0000000 _B
		R/W	R/W	R/W	R/W	R/W	R/W	R/W	

CCRL0/1 (Counter Control Register Low ch0/ch1)

Address : 00006C _H	7	6	5	4	3	2	1	0	Initial value
Address : 000070 _H	UDMS	CTUT	UCRE	RLDE	UDCC	CGSC	CGE1	CGE0	0X00X000 _B
	R/W	W	R/W	R/W	W	R/W	R/W	R/W	

CSR0/1 (Counter Status Register ch0/ch1)

Address : 000072 _H	7	6	5	4	3	2	1	0	Initial value
Address : 000074 _H	CSTR	CITE	UDIE	CMPF	OVFF	UDFF	UDF1	UDF0	0000000 _B
	R/W	R/W	R/W	R/W	R/W	R/W	R	R	

UDCR0/1 (Up Down Count Register ch0/ch1)

Address : 000069 _H	15	14	13	12	11	10	9	8	Initial value
	D17	D16	D15	D14	D13	D12	D11	D10	0000000 _B
	R	R	R	R	R	R	R	R	

Address : 000068 _H	7	6	5	4	3	2	1	0	Initial value
	D07	D06	D05	D04	D03	D02	D01	D00	0000000 _B
	R	R	R	R	R	R	R	R	

RCR0/1 (Reload/Compare Register ch0/ch1)

Address : 00006B _H	15	14	13	12	11	10	9	8	Initial value
	D17	D16	D15	D14	D13	D12	D11	D10	0000000 _B
	W	W	W	W	W	W	W	W	

Address : 00006A _H	7	6	5	4	3	2	1	0	Initial value
	D07	D06	D05	D04	D03	D02	D01	D00	0000000 _B
	W	W	W	W	W	W	W	W	

(3) Block Diagram

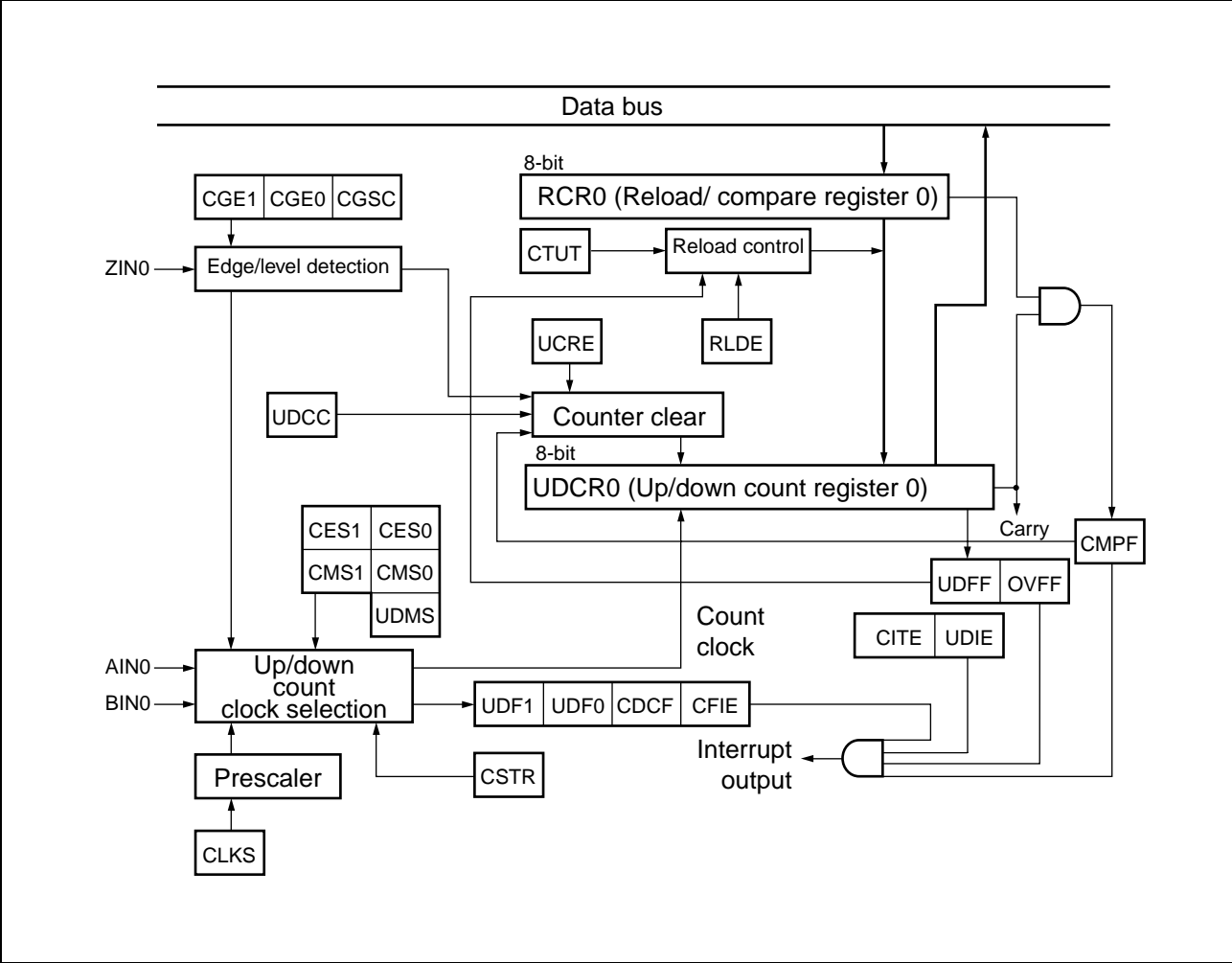

MB90480/485 Series

7. DTP/External Interrupt

The DTP (Data Transfer Peripheral) is a peripheral block that interfaces external peripherals to the F²MC-16LX CPU. The DTP receives DMA and interrupt processing requests from external peripherals and passes the requests to the F²MC-16LX CPU to activate the extended intelligent μ DMAC or interrupt processing.

(1) Detailed Register Descriptions

Interrupt/DTP Enable Register (ENIR : Enable Interrupt Request Register)								Initial value	
ENIR	7	6	5	4	3	2	1	0	00000000 _B
Address : 00000C _H	EN7	EN6	EN5	EN4	EN3	EN2	EN1	EN0	
	R/W	R/W	R/W	R/W	R/W	R/W	R/W	R/W	
Interrupt/DTP Source Register (EIRR : External Interrupt Request Register)								Initial value	
EIRR	15	14	13	12	11	10	9	8	XXXXXXXX _B
Address : 00000D _H	ER7	ER6	ER5	ER4	ER3	ER2	ER1	ER0	
	R/W	R/W	R/W	R/W	R/W	R/W	R/W	R/W	
Interrupt Level Setting Register (ELVR : External Level Register)								Initial value	
Address : 00000E _H	7	6	5	4	3	2	1	0	00000000 _B
	LB3	LA3	LB2	LA2	LB1	LA1	LB0	LA0	
	R/W	R/W	R/W	R/W	R/W	R/W	R/W	R/W	
Address : 00000F _H	15	14	13	12	11	10	9	8	00000000 _B
	LB7	LA7	LB6	LA6	LB5	LA5	LB4	LA4	
	R/W	R/W	R/W	R/W	R/W	R/W	R/W	R/W	

(2) Block Diagram

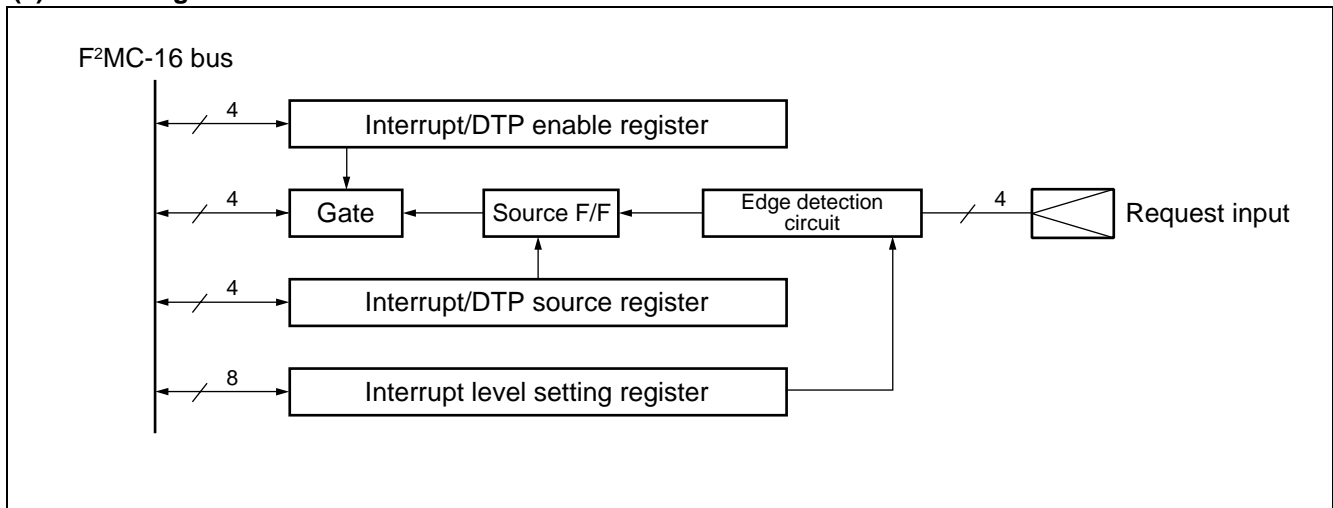

8. 16-bit Input/Output Timer

The 16-bit input/output timer module is composed of one 16-bit free run timer, six output compare and two input capture modules. These functions can be used to output six independent waveforms based on the 16-bit free run timer, enabling input pulse width measurement and external clock frequency measurement.

- Register List

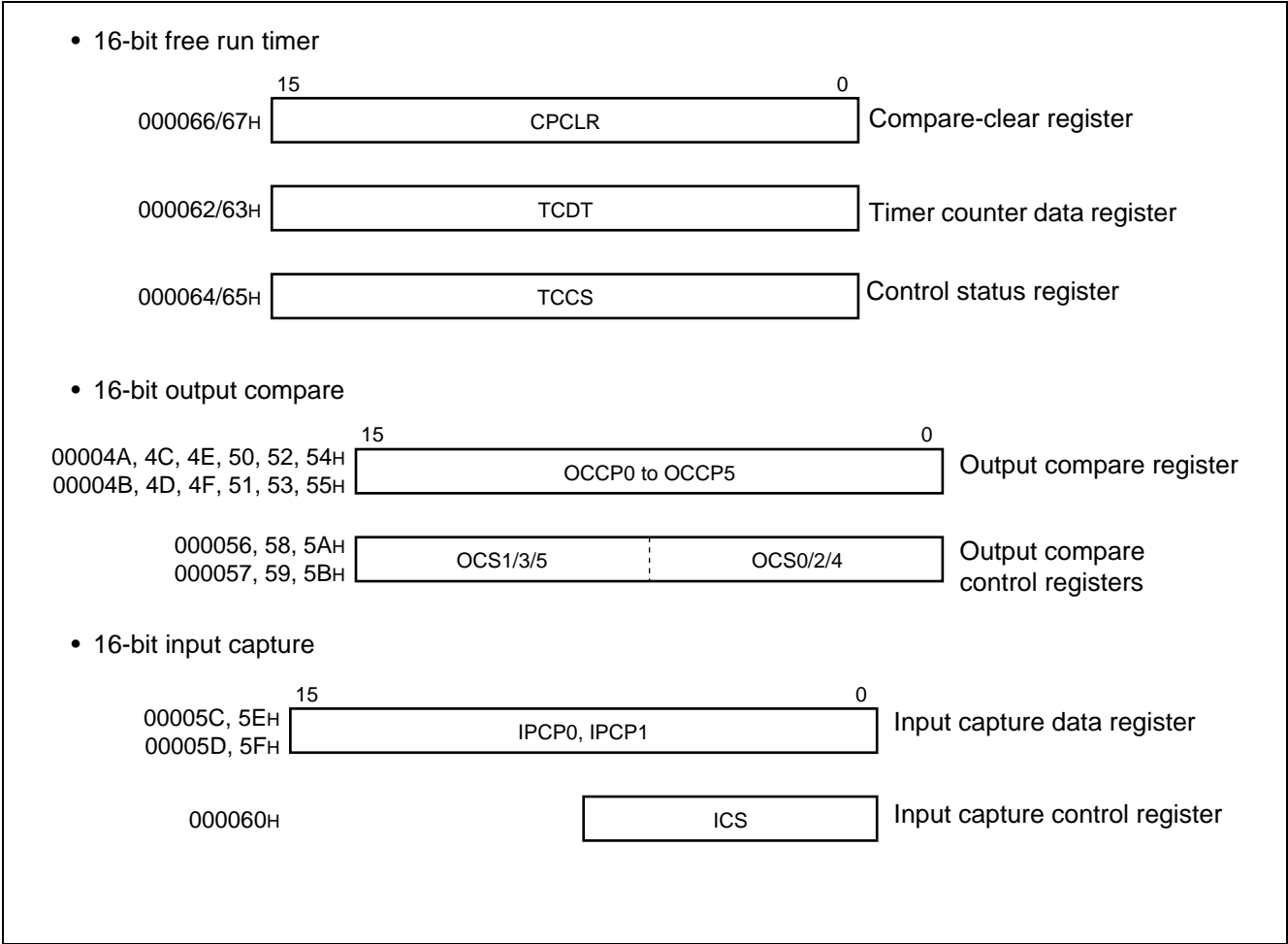

MB90480/485 Series

• Block Diagram

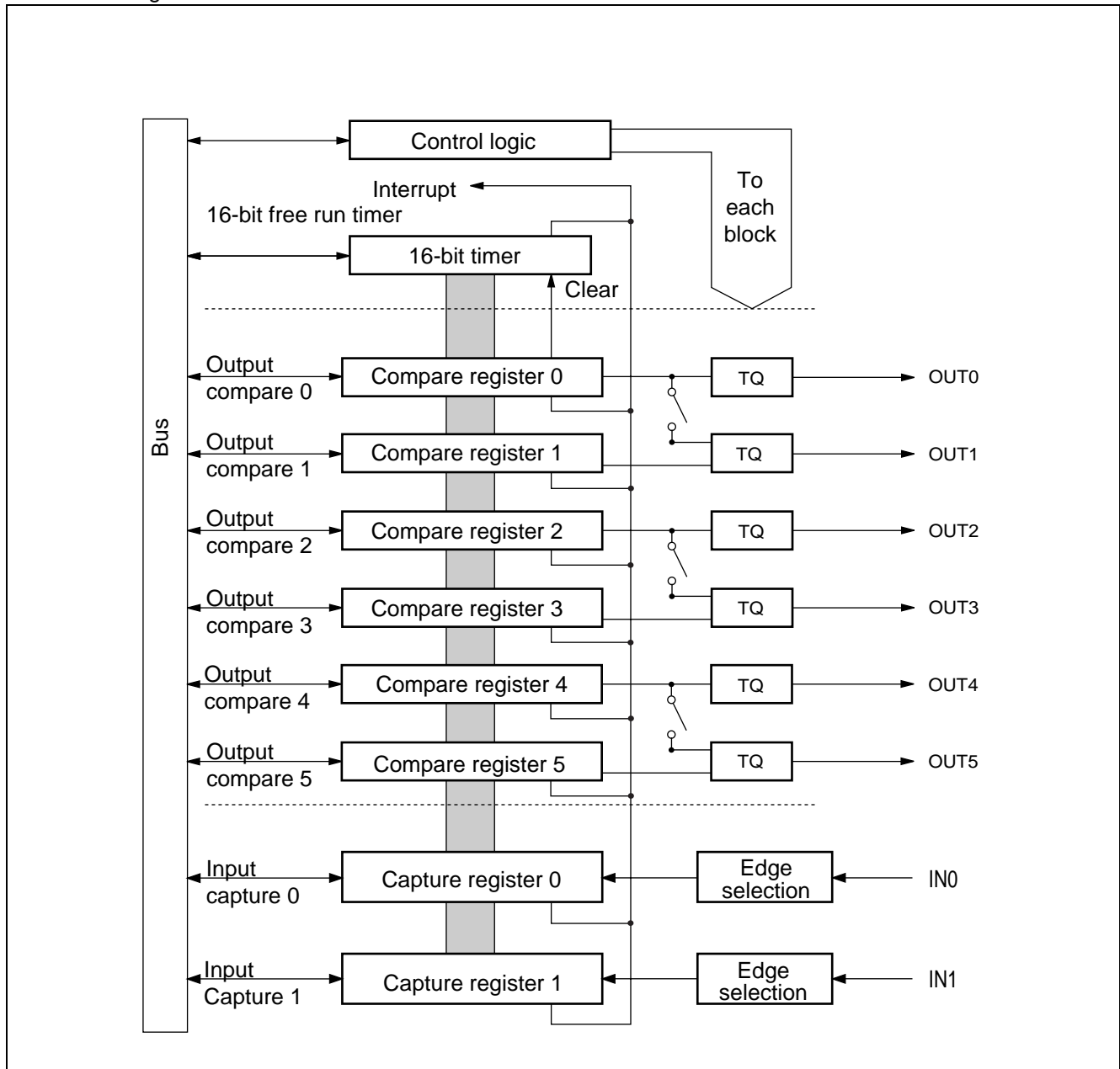

(1) 16-bit Free Run Timer

The 16-bit free run timer is composed of a 16-bit up-down counter and control status register. The counter value of this timer is used as the base timer for the input capture and output compare.

- The counter operation provides a choice of eight clock types.
- A counter overflow interrupt can be produced.
- A mode setting is available to initialize the counter value whenever the output compare value matches the value in the compare clear register.

• Register List

Compare clear register (CPCLR)								Initial value	
000067 _H	15	14	13	12	11	10	9	8	XXXXXXXX _B
	CL15	CL14	CL13	CL12	CL11	CL10	CL09	CL08	
	R/W	R/W	R/W	R/W	R/W	R/W	R/W	R/W	
								Initial value	
000066 _H	7	6	5	4	3	2	1	0	XXXXXXXX _B
	CL07	CL06	CL05	CL04	CL03	CL02	CL01	CL00	
	R/W	R/W	R/W	R/W	R/W	R/W	R/W	R/W	
Timer counter data register (TCDT)								Initial value	
000063 _H	15	14	13	12	11	10	9	8	0000000 _B
	T15	T14	T13	T12	T11	T10	T09	T08	
	R/W	R/W	R/W	R/W	R/W	R/W	R/W	R/W	
								Initial value	
000062 _H	7	6	5	4	3	2	1	0	0000000 _B
	T07	T06	T05	T04	T03	T02	T01	T00	
	R/W	R/W	R/W	R/W	R/W	R/W	R/W	R/W	
Timer control status register (TCCS)								Initial value	
000065 _H	15	14	13	12	11	10	9	8	0--0000 _B
	ECKE	—	—	MSI2	MSI1	MSI0	ICLR	ICRE	
	R/W	R/W	R/W	R/W	R/W	R/W	R/W	R/W	
								Initial value	
000064 _H	7	6	5	4	3	2	1	0	0000000 _B
	IVF	IVFE	STOP	MODE	SCLR	CLK2	CLK1	CLK0	
	R/W	R/W	R/W	R/W	R/W	R/W	R/W	R/W	

MB90480/485 Series

- Block Diagram

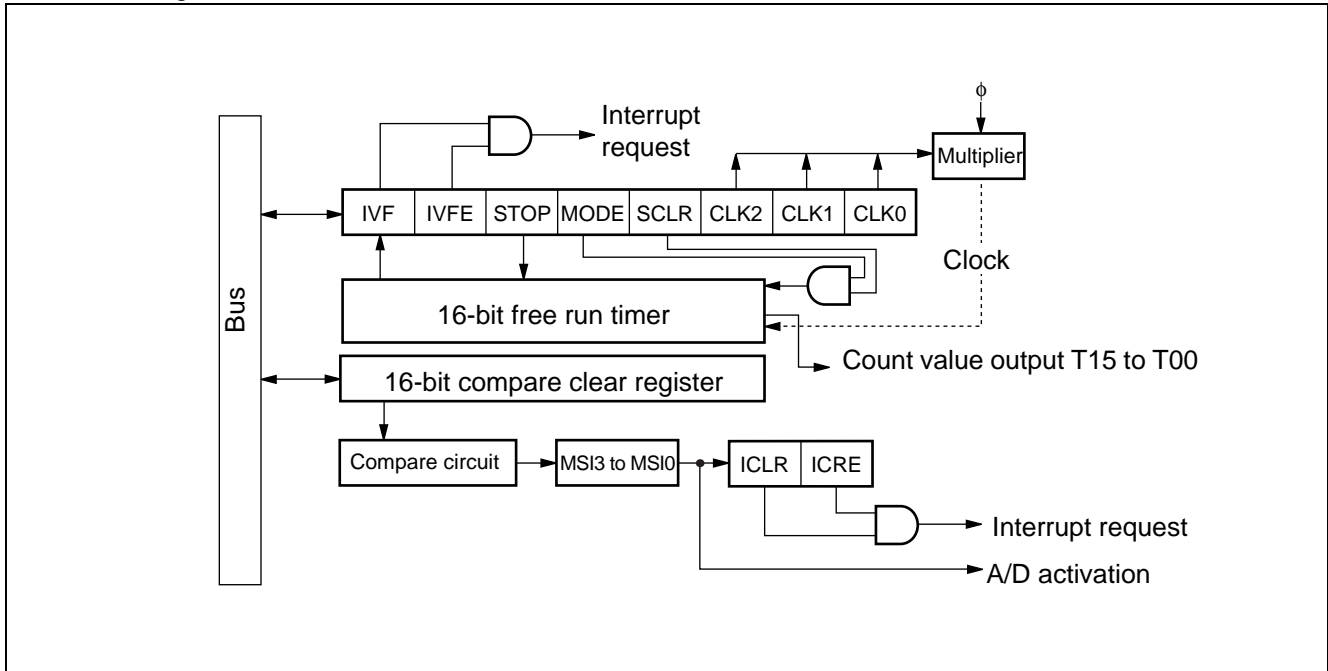

(2) Output Compare

The output compare module is composed of a 16-bit compare register, compare output pin group, and control register. When the value in the compare register in this module matches the 16-bit free run timer, the pin output levels can be inverted and an interrupt generated.

- There are six compare registers in all, each operating independently. A setting is available to allow two compare registers to be used to control output.
- Interrupts can be set in terms of compare match events.

- Register List

Output compare registers (OCCP0 to OCCP5)								Initial value	
00004B _H	15	14	13	12	11	10	9	8	00000000 _B
00004D _H	C15	C14	C13	C12	C11	C10	C09	C08	
00004F _H	R/W	R/W	R/W	R/W	R/W	R/W	R/W	R/W	
000051 _H									
000053 _H									
000055 _H									
								Initial value	
00004A _H	7	6	5	4	3	2	1	0	00000000 _B
00004C _H	C07	C06	C05	C04	C03	C02	C01	C00	
00004E _H	R/W	R/W	R/W	R/W	R/W	R/W	R/W	R/W	
000050 _H									
000052 _H									
000054 _H									
Output control registers (OCS1/OCS3/OCS5)								Initial value	
000057 _H	15	14	13	12	11	10	9	8	---0000 _B
000059 _H	—	—	—	CMOD	OTE1	OTE0	OTD1	OTD0	
00005B _H	—	—	—	R/W	R/W	R/W	R/W	R/W	
Output control registers (OCS0/OCS2/OCS4)								Initial values	
000056 _H	7	6	5	4	3	2	1	0	0000--00 _B
000058 _H	ICPIC	ICP0	ICE1	ICE0	—	—	CST1	CST0	
00005A _H	R/W	R/W	R/W	R/W	—	—	R/W	R/W	

MB90480/485 Series

• Block Diagram

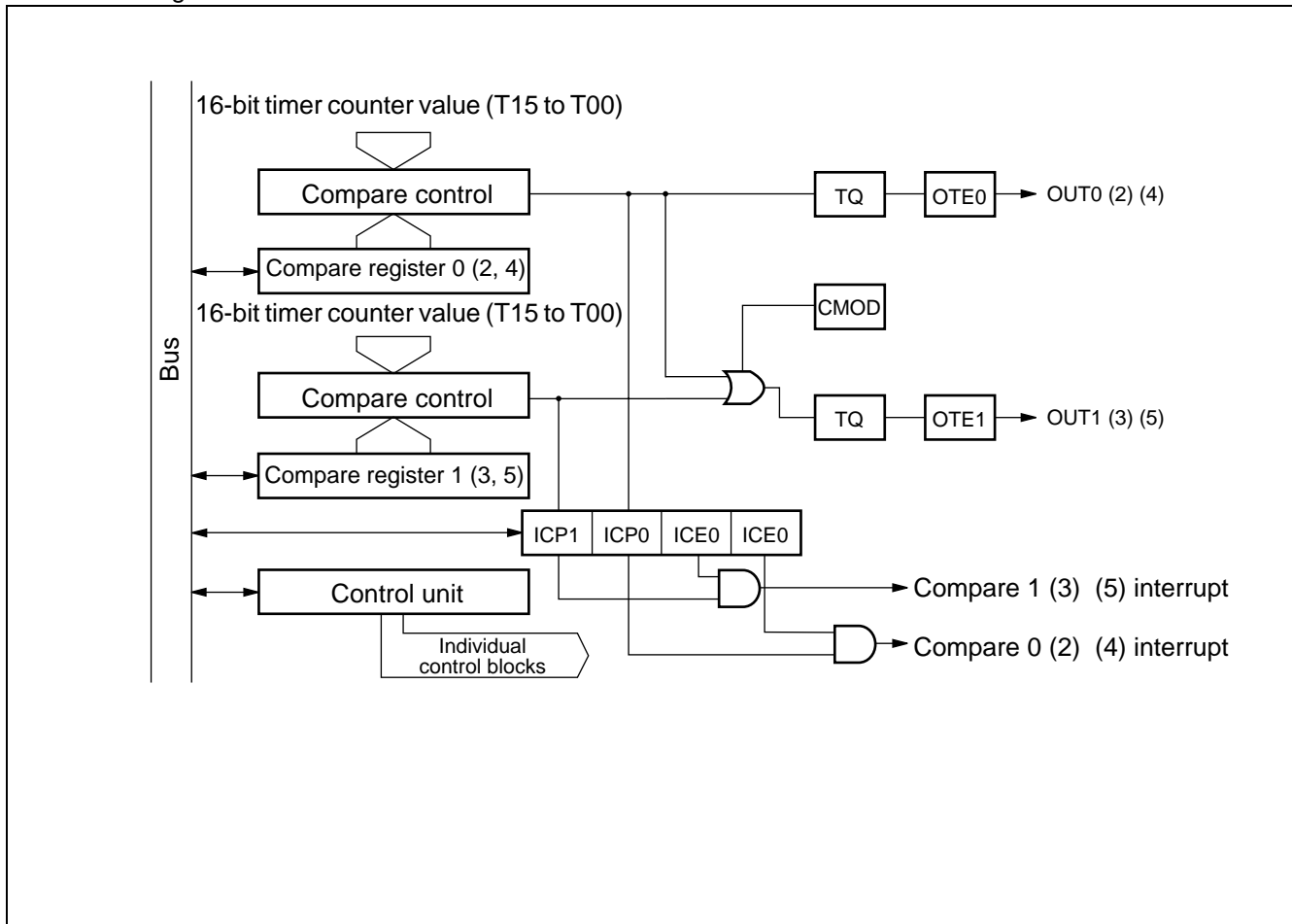

(3) Input Capture

The input capture module performs the functions of detecting the rising edge, falling edge, or both edges of signal input from external circuits, and saving the 16-bit free run timer value at that moment to a register. An interrupt can also be generated at the instant of edge detection.

The input capture module consists of input capture registers and a control register. Each input capture module has its own external input pin.

- Section of three types of valid edge for external input signals.
Rising edge, falling edge, both edges.
- An interrupt can be generated when a valid edge is detected in the external input signal.

• Register List

Input capture data register (IPCP0, IPCP1)			Initial value XXXXXXXX _B																								
00005D _H 00005F _H	<table border="1"> <tr> <td>15</td><td>14</td><td>13</td><td>12</td><td>11</td><td>10</td><td>9</td><td>8</td> </tr> <tr> <td>CP15</td><td>CP14</td><td>CP13</td><td>CP12</td><td>CP11</td><td>CP10</td><td>CP09</td><td>CP08</td> </tr> <tr> <td>R</td><td>R</td><td>R</td><td>R</td><td>R</td><td>R</td><td>R</td><td>R</td> </tr> </table>	15	14	13	12	11	10	9	8	CP15	CP14	CP13	CP12	CP11	CP10	CP09	CP08	R	R	R	R	R	R	R	R		
15	14	13	12	11	10	9	8																				
CP15	CP14	CP13	CP12	CP11	CP10	CP09	CP08																				
R	R	R	R	R	R	R	R																				
00005C _H 00005E _H	<table border="1"> <tr> <td>7</td><td>6</td><td>5</td><td>4</td><td>3</td><td>2</td><td>1</td><td>0</td> </tr> <tr> <td>CP07</td><td>CP06</td><td>CP05</td><td>CP04</td><td>CP03</td><td>CP02</td><td>CP01</td><td>CP00</td> </tr> <tr> <td>R</td><td>R</td><td>R</td><td>R</td><td>R</td><td>R</td><td>R</td><td>R</td> </tr> </table>	7	6	5	4	3	2	1	0	CP07	CP06	CP05	CP04	CP03	CP02	CP01	CP00	R	R	R	R	R	R	R	R		Initial value XXXXXXXX _B
7	6	5	4	3	2	1	0																				
CP07	CP06	CP05	CP04	CP03	CP02	CP01	CP00																				
R	R	R	R	R	R	R	R																				
Input capture control register (ICS0, ICS1)			Initial value 00000000 _B																								
000060 _H	<table border="1"> <tr> <td>7</td><td>6</td><td>5</td><td>4</td><td>3</td><td>2</td><td>1</td><td>0</td> </tr> <tr> <td>ICP1</td><td>ICP0</td><td>ICE1</td><td>ICE0</td><td>EG11</td><td>EG10</td><td>EG01</td><td>EG00</td> </tr> <tr> <td>R/W</td><td>R/W</td><td>R/W</td><td>R/W</td><td>R/W</td><td>R/W</td><td>R/W</td><td>R/W</td> </tr> </table>	7	6	5	4	3	2	1	0	ICP1	ICP0	ICE1	ICE0	EG11	EG10	EG01	EG00	R/W	R/W	R/W	R/W	R/W	R/W	R/W	R/W		
7	6	5	4	3	2	1	0																				
ICP1	ICP0	ICE1	ICE0	EG11	EG10	EG01	EG00																				
R/W	R/W	R/W	R/W	R/W	R/W	R/W	R/W																				

• Block Diagram

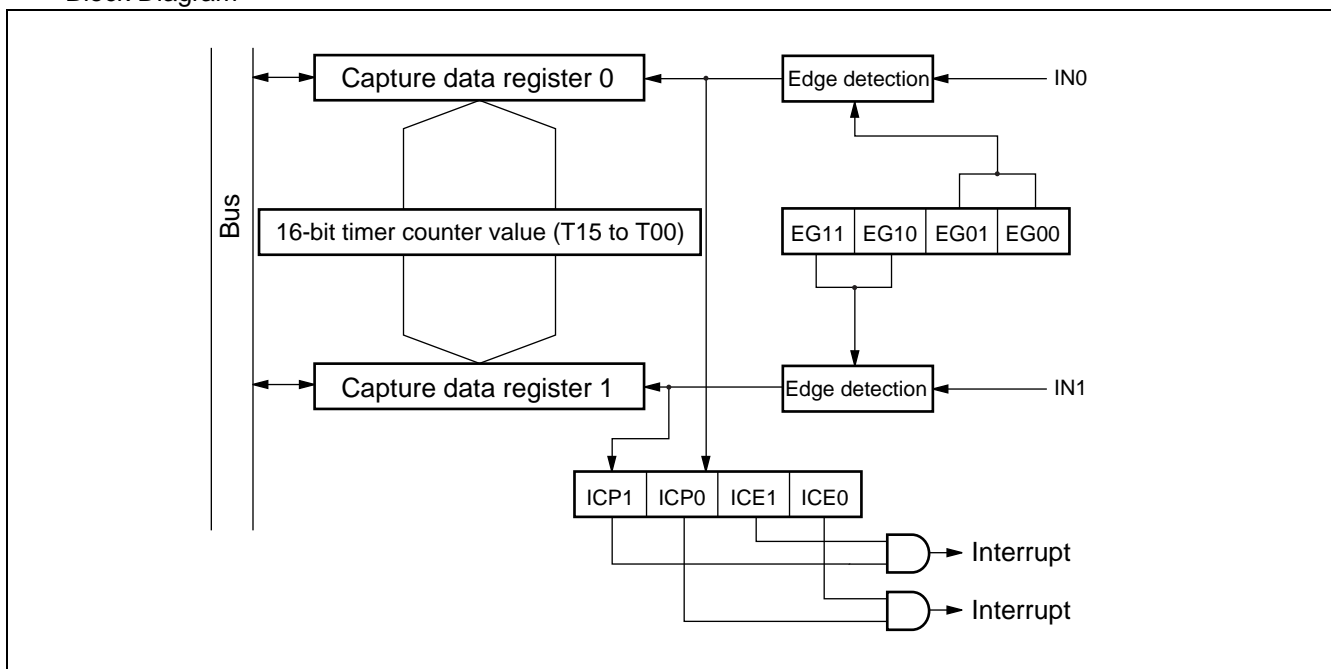

MB90480/485 Series

9. I²C Interface (MB90485 series only)

The I²C interface is a serial I/O port supporting the Inter IC BUS. Serves as a master/slave device on the I²C bus. The I²C interface has the following functions.

- Master/slave transmit/receive
- Arbitration function
- Clock synchronization
- Slave address/general call address detection function
- Forwarding direction detection function
- Start condition repeated generation and detection
- Bus error detection function

(1) Register List

Bus Status Register (IBSR)		Initial value																								
000088 _H	<table border="1"> <tr> <td>7</td><td>6</td><td>5</td><td>4</td><td>3</td><td>2</td><td>1</td><td>0</td> </tr> <tr> <td>BB</td><td>RSC</td><td>AL</td><td>LRB</td><td>TRX</td><td>AAS</td><td>GCA</td><td>FBT</td> </tr> <tr> <td>R</td><td>R</td><td>R</td><td>R</td><td>R</td><td>R</td><td>R</td><td>R</td> </tr> </table>	7	6	5	4	3	2	1	0	BB	RSC	AL	LRB	TRX	AAS	GCA	FBT	R	R	R	R	R	R	R	R	0 0 0 0 0 0 0 0 _B
7	6	5	4	3	2	1	0																			
BB	RSC	AL	LRB	TRX	AAS	GCA	FBT																			
R	R	R	R	R	R	R	R																			
Bus control register (IBCR)		Initial value																								
000089 _H	<table border="1"> <tr> <td>15</td><td>14</td><td>13</td><td>12</td><td>11</td><td>10</td><td>9</td><td>8</td> </tr> <tr> <td>BER</td><td>BEIE</td><td>SCC</td><td>MSS</td><td>ACK</td><td>GCAA</td><td>INTE</td><td>INT</td> </tr> <tr> <td>R/W</td><td>R/W</td><td>R/W</td><td>R/W</td><td>R/W</td><td>R/W</td><td>R/W</td><td>R/W</td> </tr> </table>	15	14	13	12	11	10	9	8	BER	BEIE	SCC	MSS	ACK	GCAA	INTE	INT	R/W	R/W	R/W	R/W	R/W	R/W	R/W	R/W	0 0 0 0 0 0 0 0 _B
15	14	13	12	11	10	9	8																			
BER	BEIE	SCC	MSS	ACK	GCAA	INTE	INT																			
R/W	R/W	R/W	R/W	R/W	R/W	R/W	R/W																			
Clock control register (ICCR)		Initial value																								
00008A _H	<table border="1"> <tr> <td>7</td><td>6</td><td>5</td><td>4</td><td>3</td><td>2</td><td>1</td><td>0</td> </tr> <tr> <td>—</td><td>—</td><td>EN</td><td>CS4</td><td>CS3</td><td>CS2</td><td>CS1</td><td>CS0</td> </tr> <tr> <td>—</td><td>—</td><td>R/W</td><td>R/W</td><td>R/W</td><td>R/W</td><td>R/W</td><td>R/W</td> </tr> </table>	7	6	5	4	3	2	1	0	—	—	EN	CS4	CS3	CS2	CS1	CS0	—	—	R/W	R/W	R/W	R/W	R/W	R/W	-- 0 XXXXX _B
7	6	5	4	3	2	1	0																			
—	—	EN	CS4	CS3	CS2	CS1	CS0																			
—	—	R/W	R/W	R/W	R/W	R/W	R/W																			
Address register (IADR)		Initial value																								
00008B _H	<table border="1"> <tr> <td>15</td><td>14</td><td>13</td><td>12</td><td>11</td><td>10</td><td>9</td><td>8</td> </tr> <tr> <td>—</td><td>A6</td><td>A5</td><td>A4</td><td>A3</td><td>A2</td><td>A1</td><td>A0</td> </tr> <tr> <td>—</td><td>R/W</td><td>R/W</td><td>R/W</td><td>R/W</td><td>R/W</td><td>R/W</td><td>R/W</td> </tr> </table>	15	14	13	12	11	10	9	8	—	A6	A5	A4	A3	A2	A1	A0	—	R/W	R/W	R/W	R/W	R/W	R/W	R/W	- XXXXXXX _B
15	14	13	12	11	10	9	8																			
—	A6	A5	A4	A3	A2	A1	A0																			
—	R/W	R/W	R/W	R/W	R/W	R/W	R/W																			
Data register (IDAR)		Initial value																								
00008C _H	<table border="1"> <tr> <td>7</td><td>6</td><td>5</td><td>4</td><td>3</td><td>2</td><td>1</td><td>0</td> </tr> <tr> <td>D7</td><td>D6</td><td>D5</td><td>D4</td><td>D3</td><td>D2</td><td>D1</td><td>D0</td> </tr> <tr> <td>R/W</td><td>R/W</td><td>R/W</td><td>R/W</td><td>R/W</td><td>R/W</td><td>R/W</td><td>R/W</td> </tr> </table>	7	6	5	4	3	2	1	0	D7	D6	D5	D4	D3	D2	D1	D0	R/W	R/W	R/W	R/W	R/W	R/W	R/W	R/W	XXXXXXXX _B
7	6	5	4	3	2	1	0																			
D7	D6	D5	D4	D3	D2	D1	D0																			
R/W	R/W	R/W	R/W	R/W	R/W	R/W	R/W																			

(2) Block Diagram

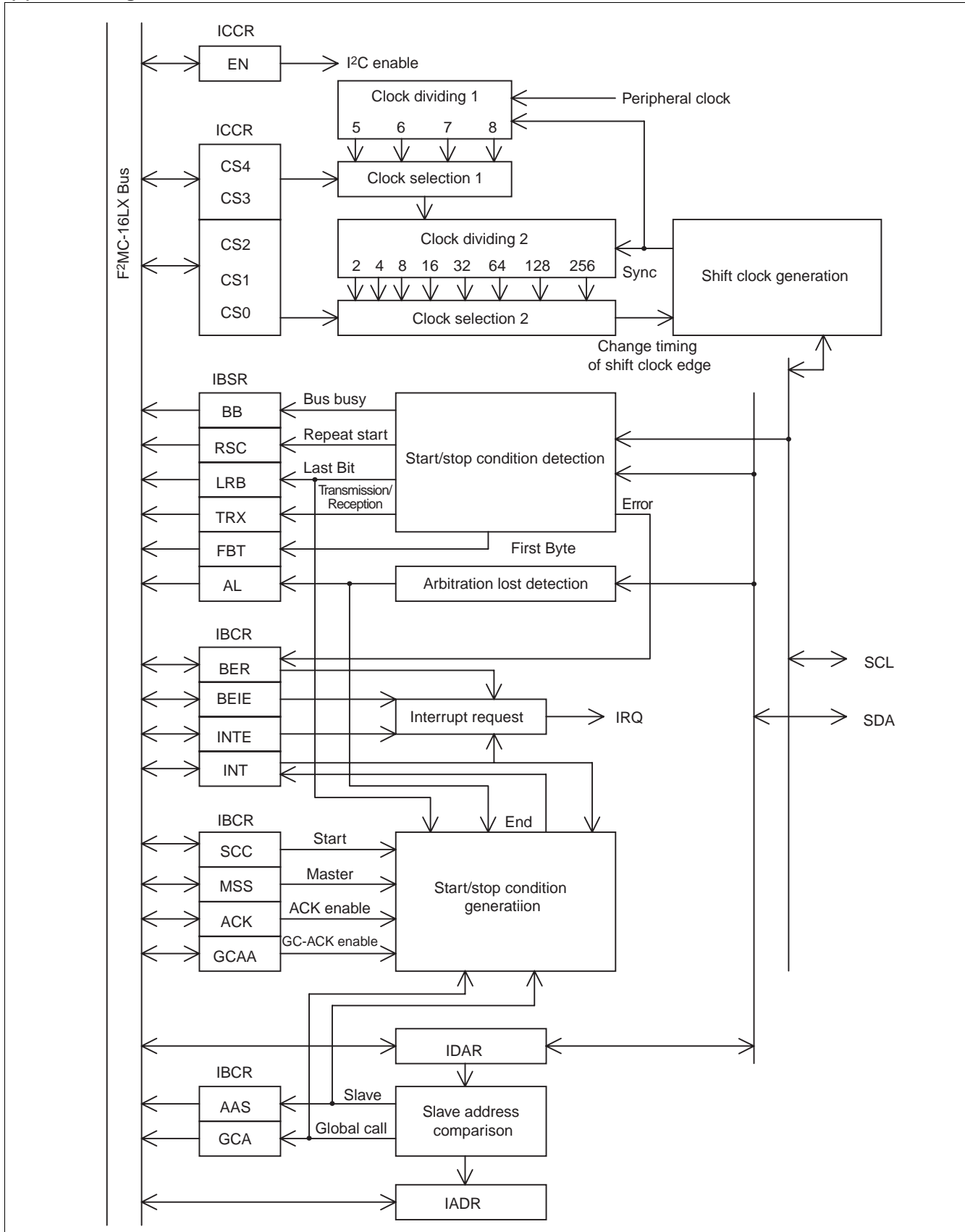

MB90480/485 Series

10. 16-bit Reload Timer

The 16-bit reload timer provides a choice of functions, including internal clock signals that count down in synchronization with three types of internal clock, as well as an event count mode that counts down at specified edge detection events in pulse signals input from external pins. This timer defines an underflow as a change in count value from 0000H to FFFFH. Thus an underflow will occur when counting from the value "reload register setting value + 1". The choice of counting operations includes reload mode, in which the count setting values is reload and counting continues following an underflow event, and one-shot mode, in which an underflow event causes counting to stop. An interrupt can be generated at counter underflow, and the timer is DTC compatible.

(1) Register List

- TMCSR (Timer control status register)

Timer control status register (high) (TMCSR)

0000CB _H	15	14	13	12	11	10	9	8	
	—	—	—	—	CSL1	CSL0	MOD2	MOD1	
	—	—	—	—	R/W	R/W	R/W	R/W	Read/Write
	—	—	—	—	0	0	0	0	Initial value

Timer control status register (low) (TMCSR)

0000CA _H	7	6	5	4	3	2	1	0	
	MOD0	OUTE	OUTL	RELD	INTE	UF	CNTE	TRG	
	R/W	R/W	R/W	R/W	R/W	R/W	R/W	R/W	Read/Write
	0	0	0	0	0	0	0	0	Initial value

- 16-bit timer register/16-bit reload register

TMR/TMRLR (high)

0000CD _H	15	14	13	12	11	10	9	8	
	D15	D14	D13	D12	D11	D10	D09	D08	
	R/W	R/W	R/W	R/W	R/W	R/W	R/W	R/W	Read/Write
	X	X	X	X	X	X	X	X	Initial value

TMR/TMRLR (low)

0000CC _H	7	6	5	4	3	2	1	0	
	D07	D06	D05	D04	D03	D02	D01	D00	
	R/W	R/W	R/W	R/W	R/W	R/W	R/W	R/W	Read/Write
	X	X	X	X	X	X	X	X	Initial value

(2) Block Diagram

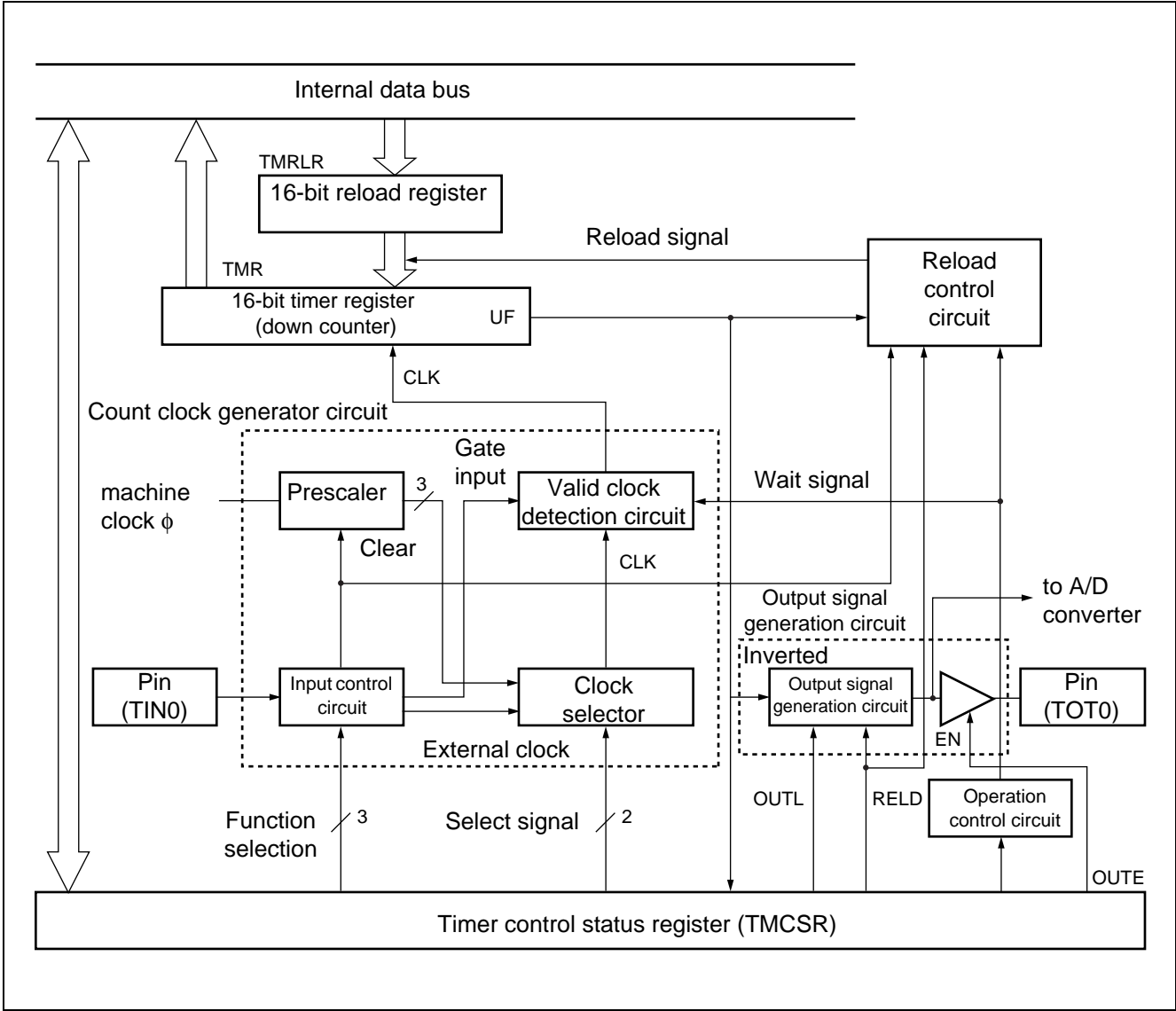

MB90480/485 Series

11. μ PG Timer (MB90485 only)

The μ PG timer performs pulse output in response to the external input.

(1) Register List

μ PG control status register (PGCSR)								Initial value	
00008EH	7	6	5	4	3	2	1	0	0 0 0 0 0 --- B
	PEN0	PE1	PE0	PMT1	PMT0	—	—	—	
	R/W	R/W	R/W	R/W	R/W	—	—	—	

(2) Block Diagram

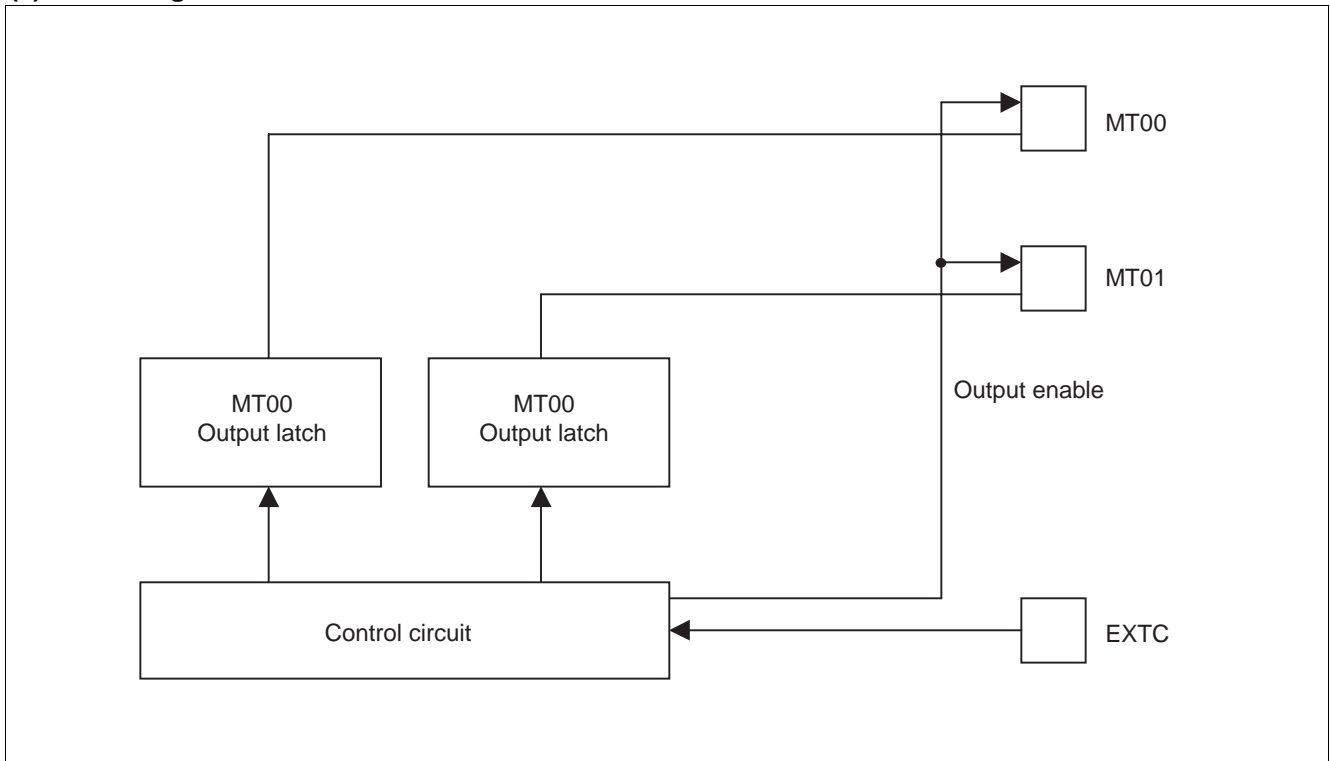

12. PWC Timer (MB90485 only)

The PWC timer is a 16-bit multifunction up-count timer capable of measuring the pulse width of the input signal. A total of three channels are provided, each consisting of a 16-bit up-count timer, an input pulse divider & divide ratio control register, a measurement input pin, and a 16-bit control register. These components provide the following functions.

Timer function : • Capable of generating an interrupt request at fixed intervals specified.
• The internal clock used as the reference clock can be selected from among three types.

Pulse width measurement function : • Measures the time between arbitrary events based on external pulse inputs.
• The internal clock used as the reference clock can be selected from among three types.
• Measurement modes
- "H" pulse width (\uparrow to \downarrow) / "L" pulse width (\uparrow to \downarrow)
- Rising cycle (\uparrow to \uparrow) / Falling cycle (\downarrow to \downarrow)
- Measurement between edges (\uparrow or \downarrow to \downarrow or \uparrow)
• The 8-bit input divider can be used for division measurement by dividing the input pulse by 22 ns ($n = 1, 2, 3, 4$) .
• An interrupt can be generated upon completion of measurement.
• One-time measurement or fast measurement can be selected.

MB90480/485 Series

(1) Register list

PWC control/status register (PWCSR0 to PWCSR2)

000077H	15	14	13	12	11	10	9	8
00007BH	STRT	STOP	EDIR	EDIE	OVIR	OVIE	ERR	Reserved
00007FH	R/W	R/W	R	R/W	R/W	R/W	R	—

Initial value
0000000X_B

PWC control/status register (PWCSR0 to PWCSR2)

000076H	7	6	5	4	3	2	1	0
00007AH	CKS1	CKS0	PIS1	PIS0	S/C	MOD2	MOD1	MOD0
00007EH	R/W	R/W	R/W	R/W	R/W	R/W	R/W	R/W

Initial value
00000000_B

PWC data buffer register (PWCR0 to PWCR2)

000079H	15	14	13	12	11	10	9	8
00007DH	D15	D14	D13	D12	D11	D10	D9	D8
000081H	R/W	R/W	R/W	R/W	R/W	R/W	R/W	R/W

Initial value
00000000_B

PWC data buffer register (PWCR0 to PWCR2)

000078H	7	6	5	4	3	2	1	0
00007CH	D7	D6	D5	D4	D3	D2	D1	D0
000080H	R/W	R/W	R/W	R/W	R/W	R/W	R/W	R/W

Initial value
00000000_B

Dividing ratio control register (DIVR0 to DIVR2)

000082H	7	6	5	4	3	2	1	0
000084H	—	—	—	—	—	—	DIV1	DIV0
000086H	—	—	—	—	—	—	R/W	R/W

Initial value
-----00_B

(2) Block Diagram

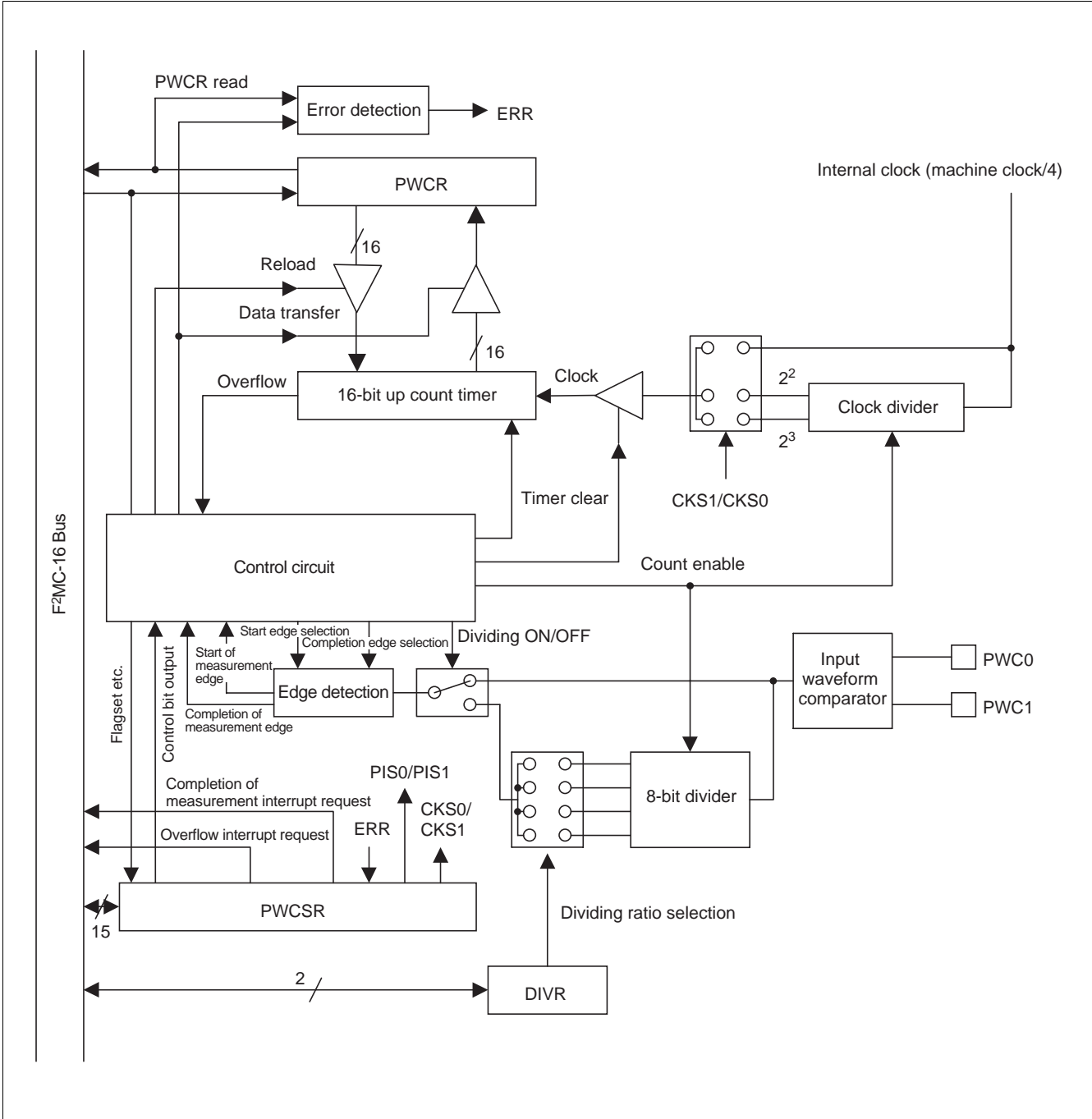

MB90480/485 Series

13. Watch Timer

The watch timer is a 15-bit timer using the sub clock. This circuit can generate interrupts at predetermined intervals. Also a setting is available to enable it to be used as the clock source for the watchdog timer.

(1) Register List

Watch timer control register (WTC)								Read/write Initial value	
7	6	5	4	3	2	1	0		
0000AA _H	WDCS	SCE	WTIE	WTOF	WTR	WTC2	WTC1	WTC0	
	R/W	R	R/W	R/W	R/W	R/W	R/W	R/W	
	1	0	0	0	1	0	0	0	

(2) Block Diagram

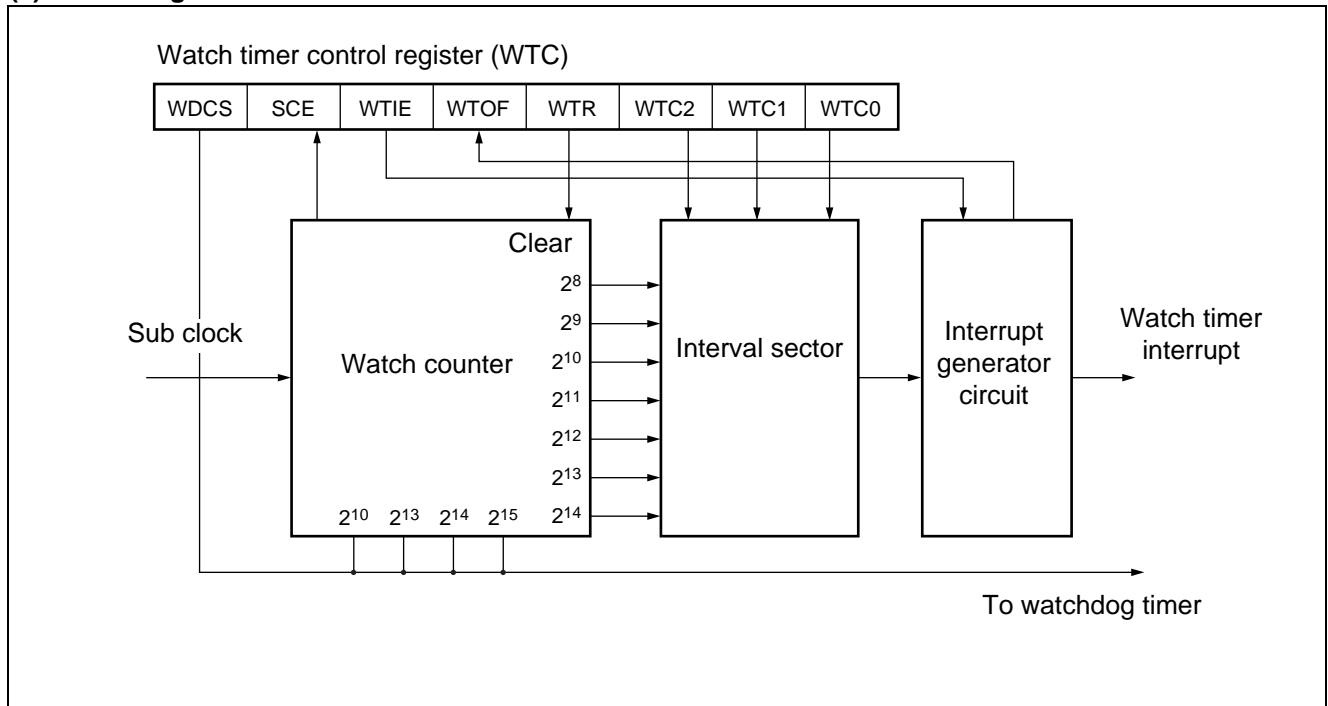

14. Watchdog timer

The watchdog timer is a 2-bit counter that uses the output from the timebase timer or watch timer as a count clock signal, and will reset the CPU if not cleared within a predetermined time interval after it is activated.

(1) Register List

Watchdog timer control register (WDTC)									
0000A8H	7	6	5	4	3	2	1	0	
	PONR	Reserved	WRST	ERST	SRST	WTE	WT1	WT0	
	R	—	R	R	R	W	W	W	Read/write
	X	X	X	X	X	1	1	1	Initial value

(2) Block Diagram

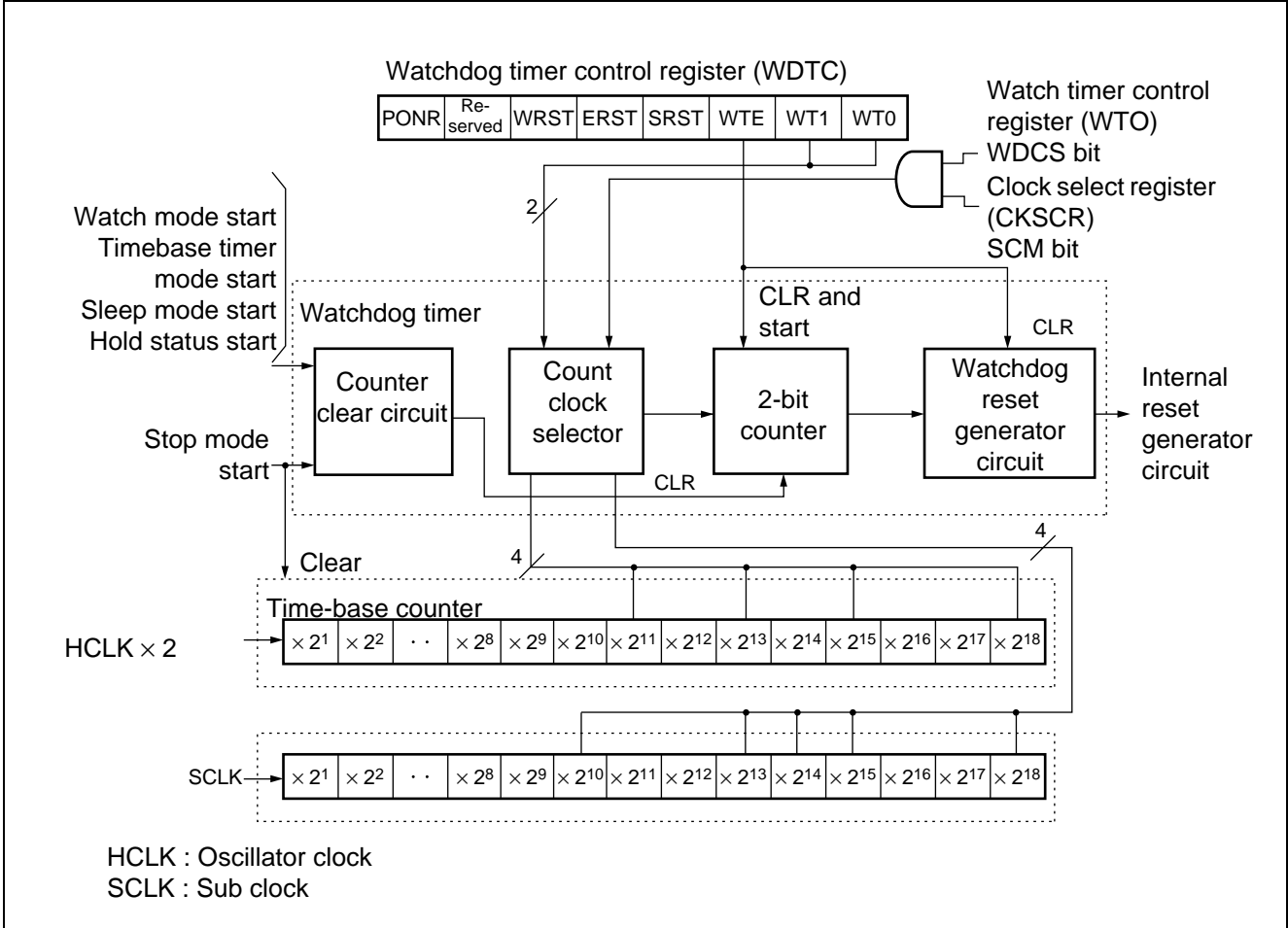

MB90480/485 Series

15. Timebase Timer

The timebase timer is an 18-bit free run counter (timebase counter) that counts up in synchronization with the internal count clock signal (base oscillator $\times 2$), and functions as an interval timer with a choice of four types of time intervals. Other functions provided by this module include timer output for the oscillator stabilization wait period, and operating clock signal feed for other timer circuits such as the watchdog timer.

(1) Register List

Timebase timer control register (TBTC)									
15	14	13	12	11	10	9	8		
0000A9H	RESV	—	—	TBIE	TBOF	TBR	TBC1	TBC0	Read/write
	R/W	—	—	R/W	R/W	W	R/W	R/W	Initial value
	1	X	X	0	0	1	0	0	

(2) Block Diagram

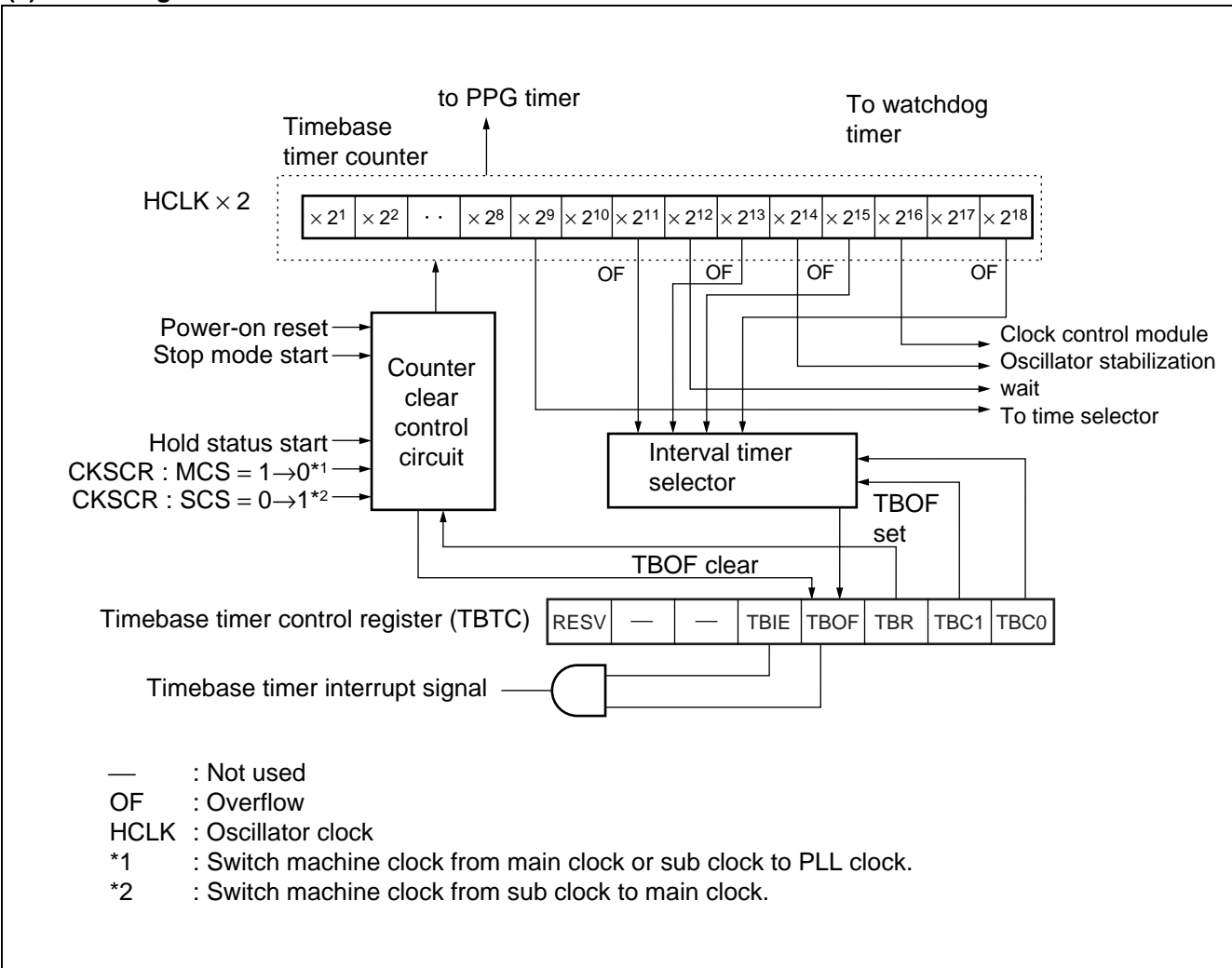

16. Clock

The clock generator module controls the operation of the internal clock circuits that serve as the operating clock for the CPU and peripheral devices. This internal clock is referred to as the machine clock, and one cycle is referred to as a machine cycle. Also, the clock signals from the base oscillator are called the oscillator clock, and those from the PLL oscillator are called the PLL clock.

(1) Register List

Clock select register (CKSCR)									
0000A1 _H	15	14	13	12	11	10	9	8	
	SCM	MCM	WS1	WS0	SCS	MCS	CS1	CS0	
	R	R	R/W	R/W	R/W	R/W	R/W	R/W	Read/write
	1	1	1	1	1	1	0	0	Initial value
PLL output select register (PLLOS)									
0000CF _H	15	14	13	12	11	10	9	8	
	—	—	—	—	—	—	—	PLL2	
	—	—	—	—	—	—	W	W	Read/write
	—	—	—	—	—	—	X	0	Initial value

MB90480/485 Series

(2) Block Diagram

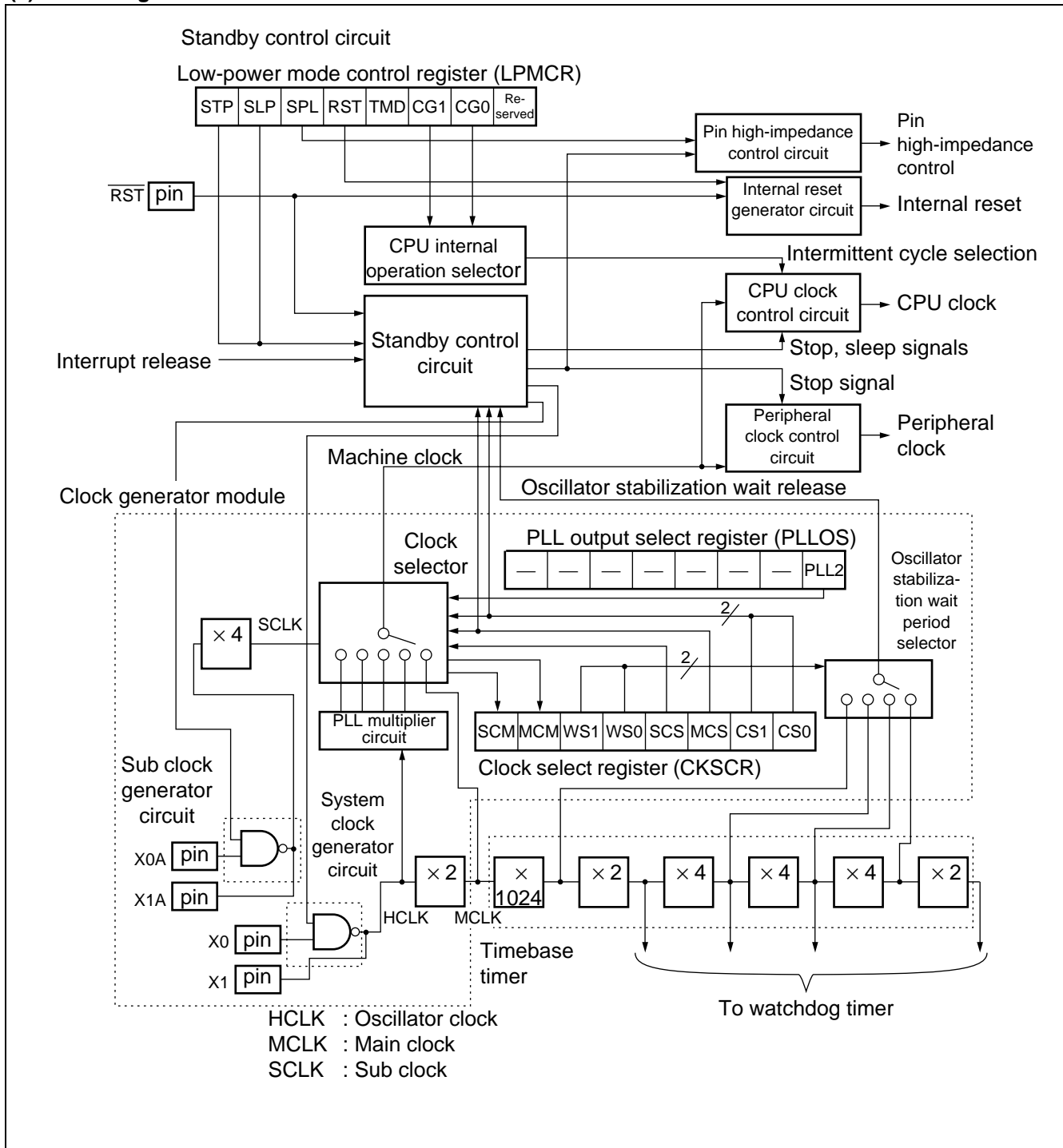

(3) Clock Feed Map

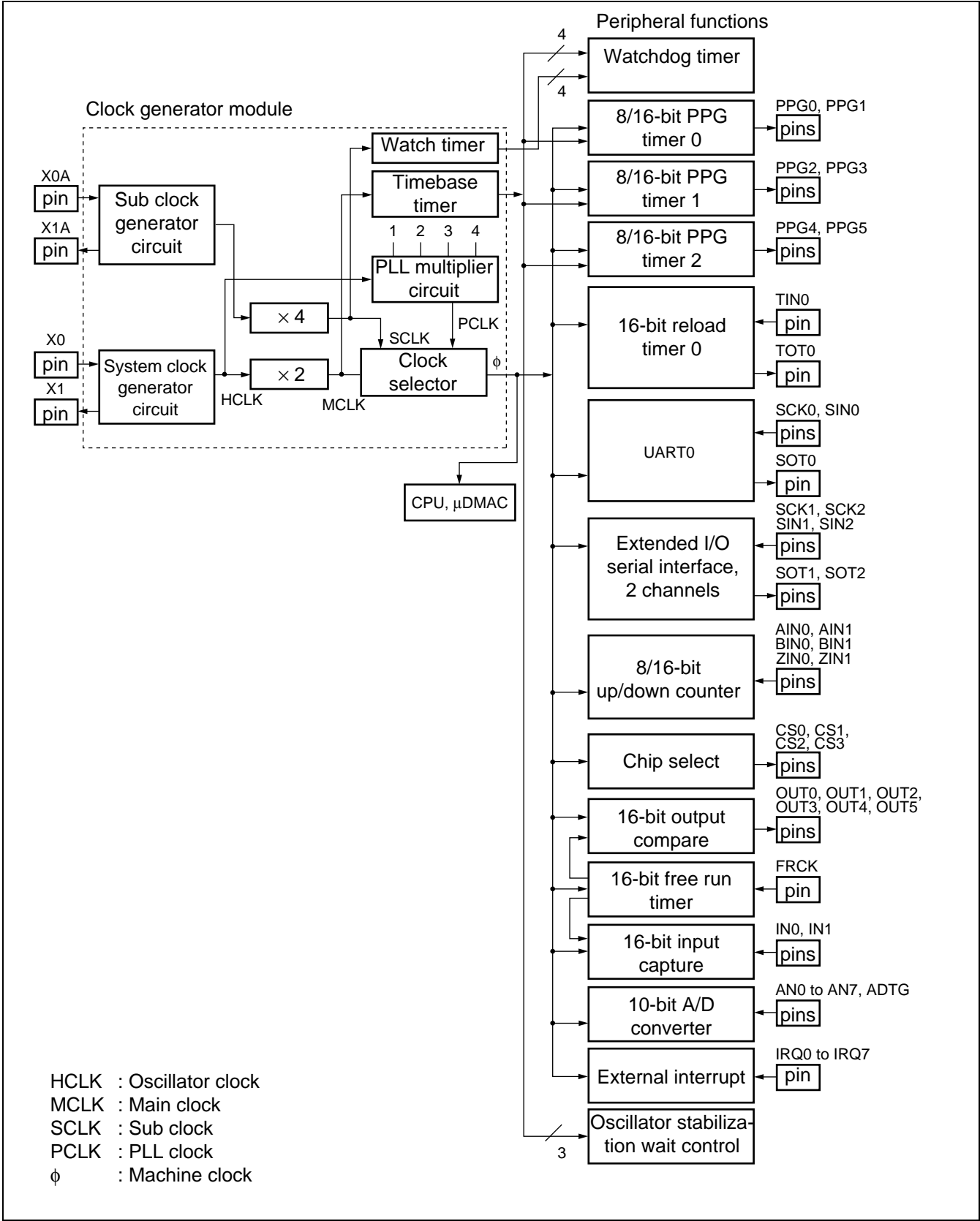

MB90480/485 Series

17. Low-power Consumption Mode

The MB90480/485 series uses operating clock selection and clock operation controls to provide the following CPU operating modes :

- Clock modes
(PLL clock mode, main clock mode, sub clock mode)
- CPU intermittent operating modes
(PLL clock intermittent mode, main clock intermittent mode, sub clock intermittent mode)
- Standby modes
(Sleep mode, timebase timer mode, stop mode, watch mode)

(1) Register List

Low-power mode control register (LPMCR)									
0000A0H	7	6	5	4	3	2	1	0	
	STP	SLP	SPL	RST	TMD	CG1	CG0	Reserved	Read/write
	W	W	R/W	W	R/W	R/W	R/W	R/W	Initial value
	0	0	0	1	1	0	0	0	

(2) Block Diagram

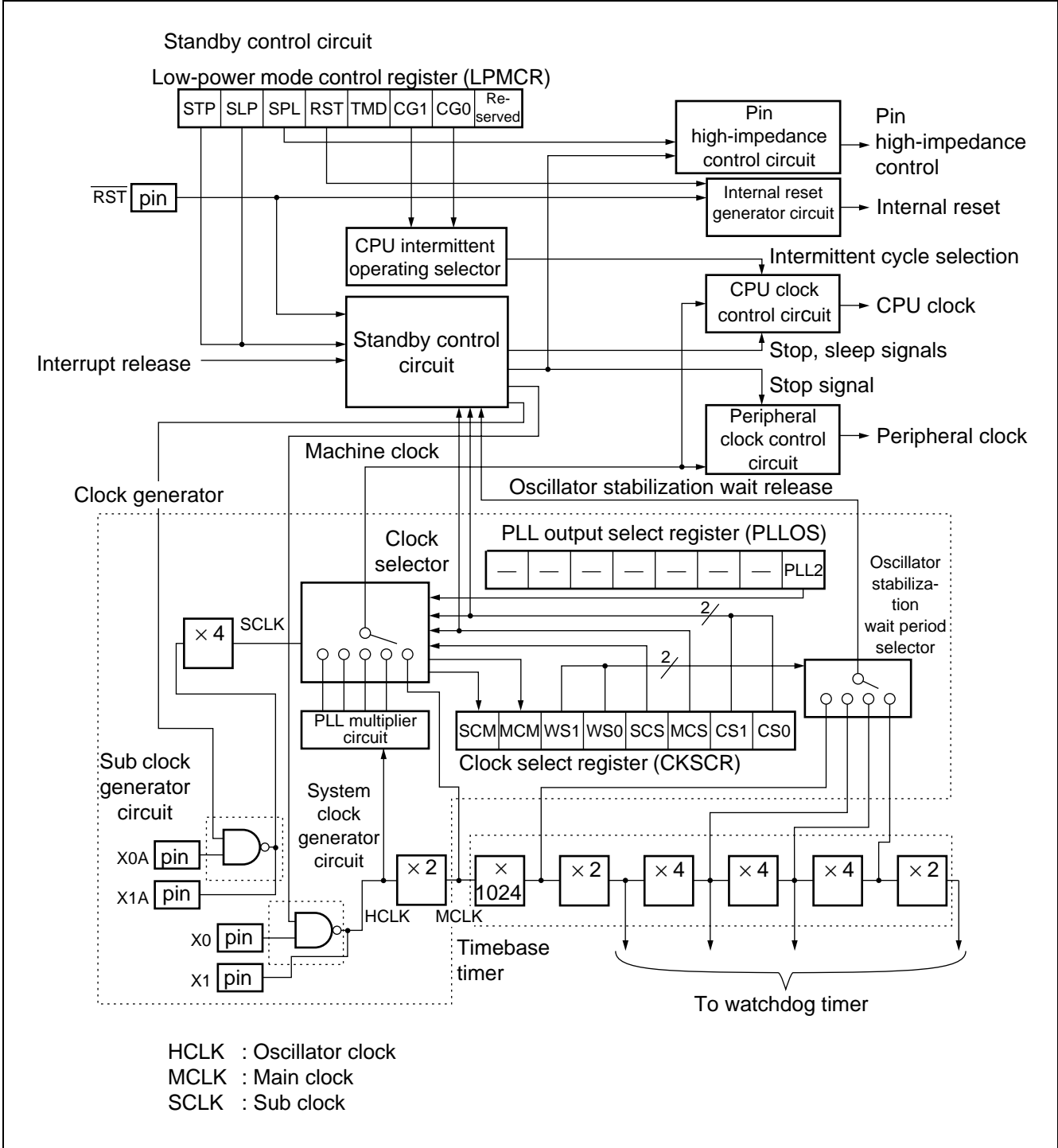

MB90480/485 Series

(3) Status Transition Chart

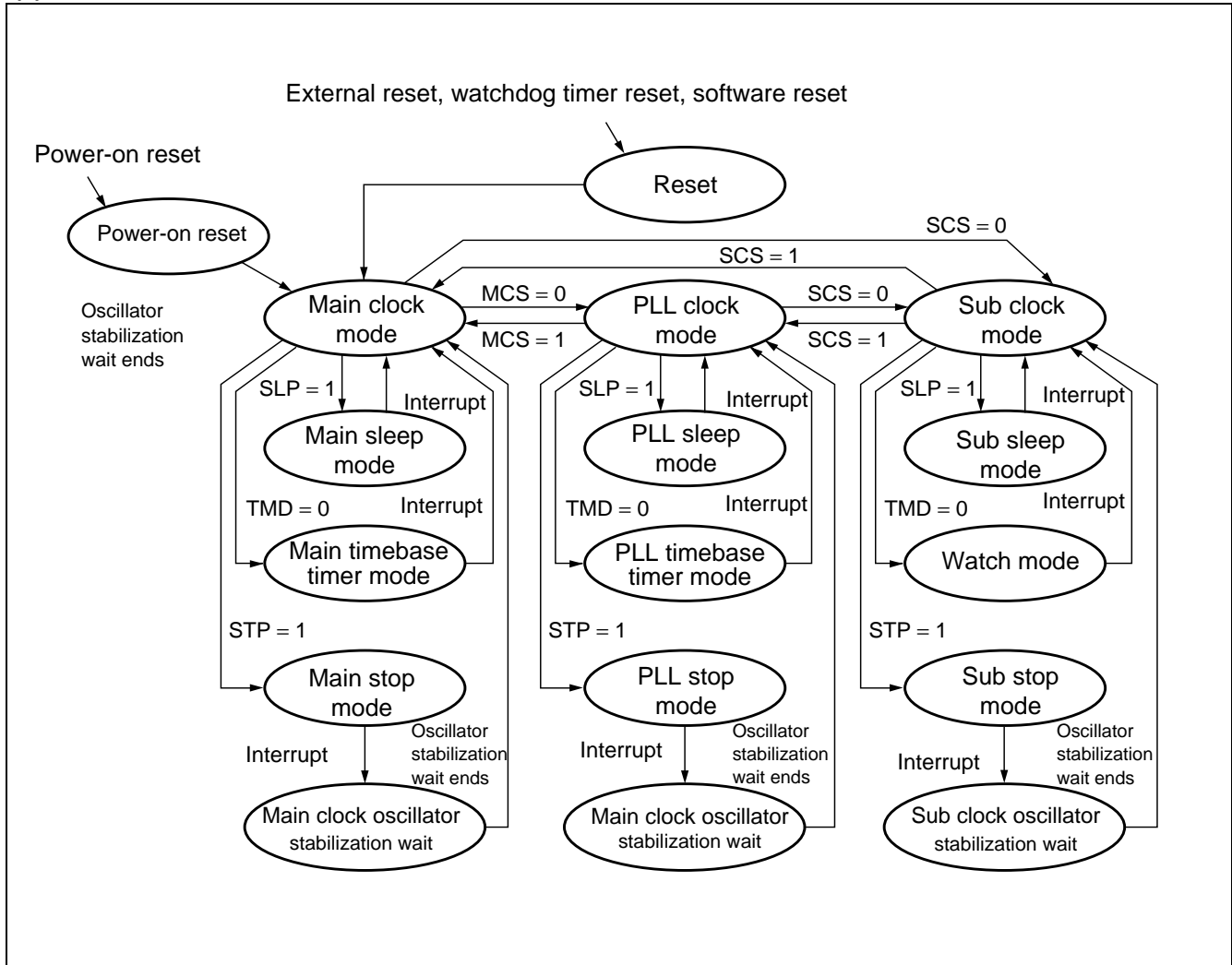

18. External Bus Pin Control Circuit

The external bus pin control circuit controls the external bus pins used to expand the CPU address/data bus connections to external circuits.

(1) Register List

- Auto ready function select register (ARSR)

Address : 0000A5H

15	14	13	12	11	10	9	8
IOR1	IOR0	HMR1	HMR0	—	—	LMR1	LMR0
W	W	W	W	—	—	W	W

Initial value
0011--00_B

- External address output control register (HACR)

Address : 0000A6H

7	6	5	4	3	2	1	0
E23	E22	E21	E20	E19	E18	E17	E16
W	W	W	W	W	W	W	W

Initial value
*****_B

- Bus control signal select register (EPCR)

Address : 0000A7H

15	14	13	12	11	10	9	8
CKE	RYE	HDE	IOBS	HMBS	WRE	LMBS	—
W	W	W	W	W	W	W	—

Initial value
1000*10_{-B}

W : Write only
 — : Not used
 * : May be either "1" or "0"

(2) Block Diagram

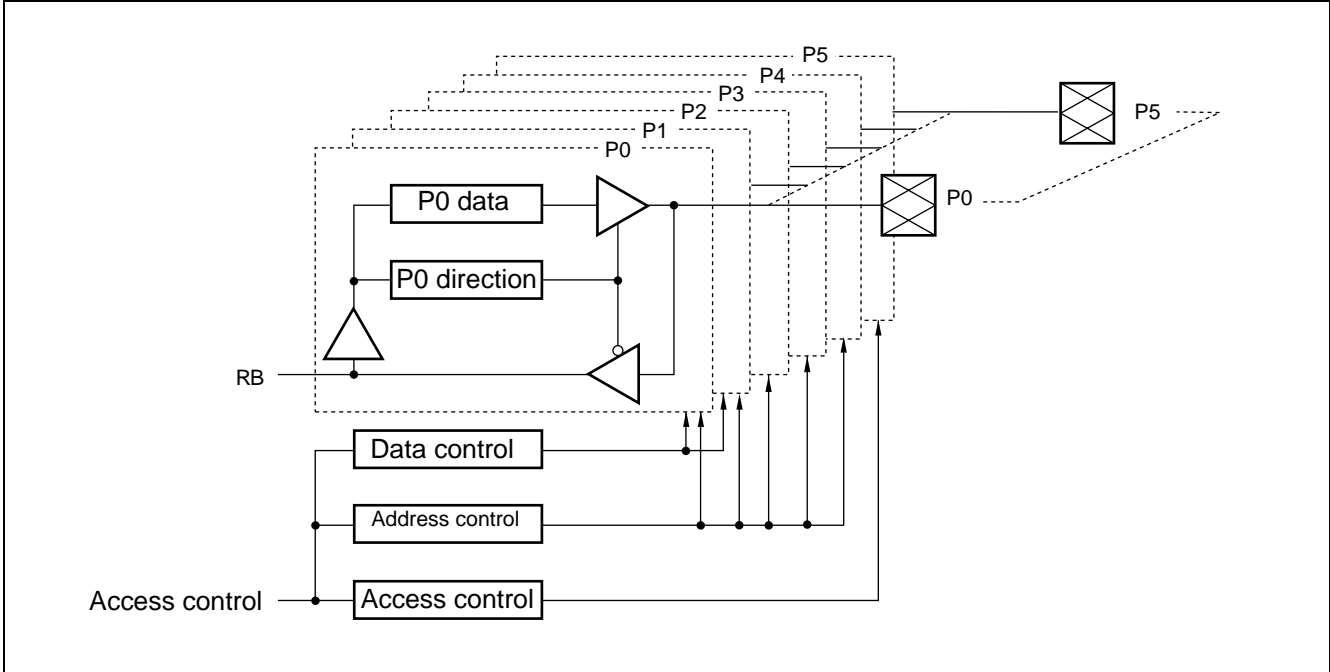

MB90480/485 Series

19. Chip Select Function Description

The chip select module generates a chip select signals, which are used to facilitate connections to external memory devices. The MB90480/485 series has four chip select output pins, each having a chip select area register setting that specifies the corresponding hardware area and select signal that is output when access to the corresponding external address is detected.

- Chip select function features

The chip select function uses two 8-bit registers for each output pin. One of these registers (CARx) is able to detect memory areas in 64 Kbytes units by specifying the upper 8-bit of the address for match detection. The other register (CMRx) can be used to expand the detection area beyond 64 Kbytes by masking bits for match detection.

Note that during external bus holds, the CS output is set to high impedance.

(1) Register List

15	8	7	0	R/W
CAR0		CMR0		R/W
CAR1		CMR1		R/W
CAR2		CMR2		R/W
CAR3		CMR3		R/W
CALR		CSCR		R/W

Chip select area mask register (CMRx)

0000C0H	7	6	5	4	3	2	1	0	Read/write initial value
0000C2H	M7	M6	M5	M4	M3	M2	M1	M0	
0000C4H	R/W	R/W	R/W	R/W	R/W	R/W	R/W	R/W	
0000C6H	0	0	0	0	1	1	1	1	

Chip select area register (CARx)

0000C1H	15	14	13	12	11	10	9	8	Read/write initial value
0000C3H	A7	A6	A5	A4	A3	A2	A1	A0	
0000C5H	R/W	R/W	R/W	R/W	R/W	R/W	R/W	R/W	
0000C7H	1	1	1	1	1	1	1	1	

Chip select control register (CSCR)

0000C8H	7	6	5	4	3	2	1	0	Read/write initial value
	—	—	—	—	OPL3	OPL2	OPL1	OPL0	
	—	—	—	—	R/W	R/W	R/W	R/W	
	—	—	—	—	0	0	0	*	

Chip select active level register (CALR)

0000C9H	15	14	13	12	11	10	9	8	Read/write initial value
	—	—	—	—	ACTL3	ACTL2	ACTL1	ACTL0	
	—	—	—	—	R/W	R/W	R/W	R/W	
	—	—	—	—	0	0	0	0	

* : The initial value of this bit is "1" or "0".
The value depends on the mode pin (MD2, MD1 and MD0) .

(2) Block Diagram

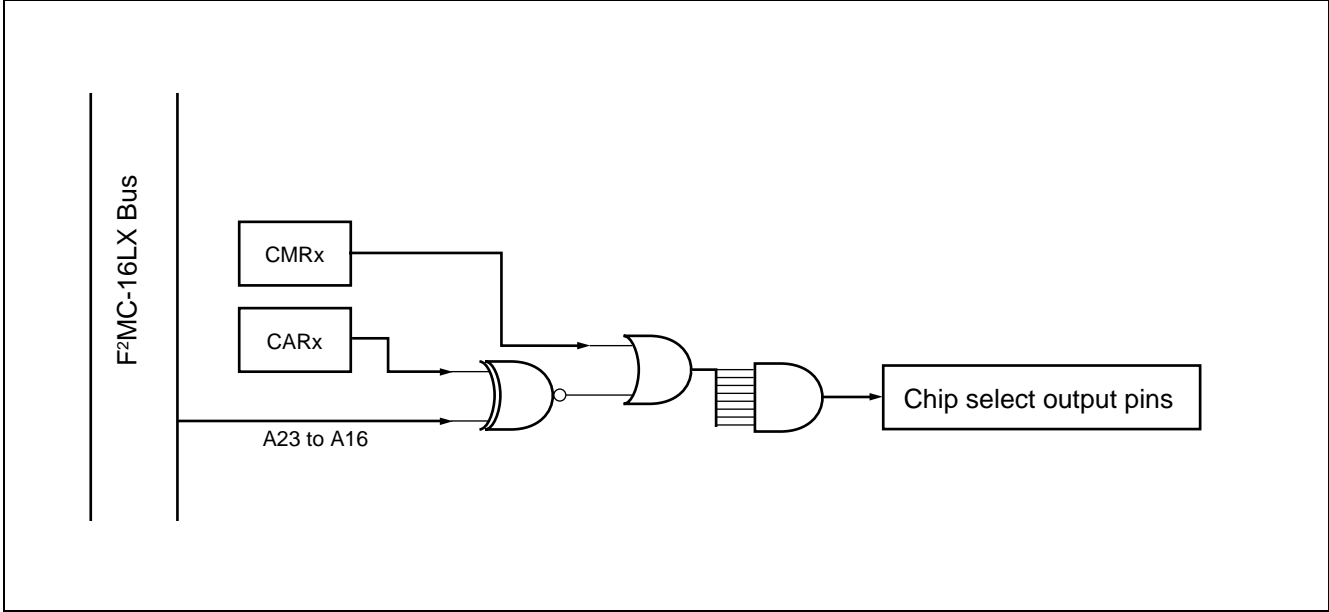

MB90480/485 Series

20. ROM Mirror Function Select Module

The ROM mirror function selection module sets the data in ROM assigned to FF bank so that the data is read by access to 00 bank.

(1) Register List

- ROM mirror function select register (ROMM)

Address : 00006F _H	15	14	13	12	11	10	9	8	Initial value
	-	-	-	-	-	-	MS	MI	-----+1 _B
							R/W	R/W	(+) : MB90F489B : Read only, fixed at "1"
							(+)		Other : Selectable, Initial value 0

- : Not used

(2) Block Diagram

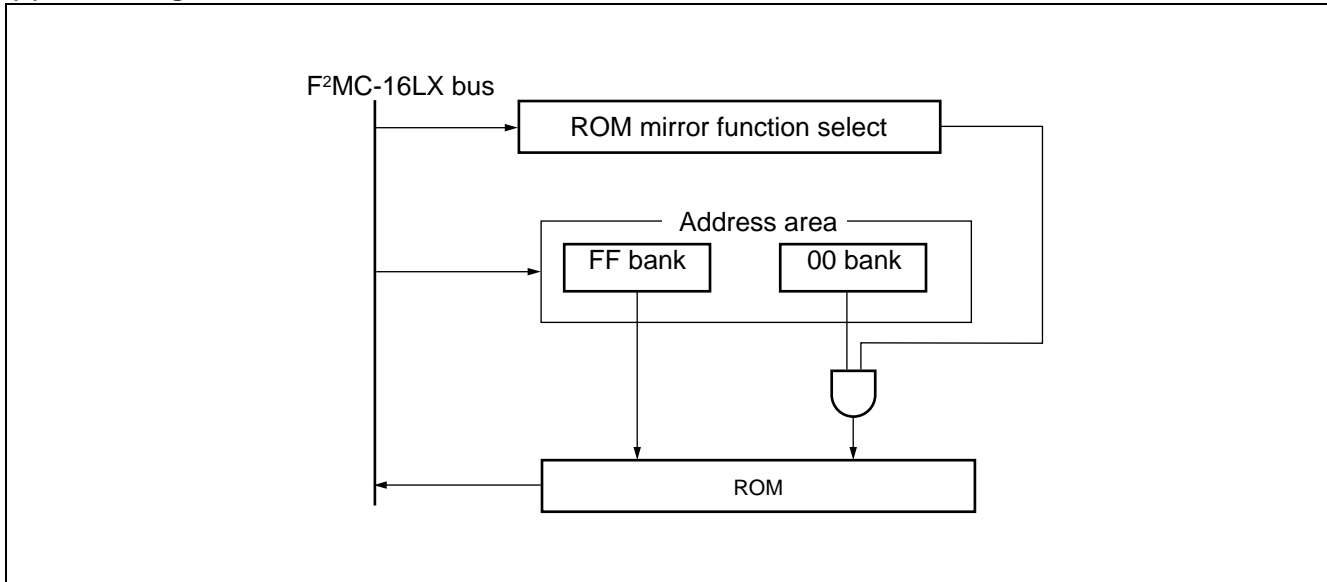

Note : Do not access ROM mirror function selection register (ROMM) on using the area of address 004000_H to 00FFFF_H (008000_H to 00FFFF_H) .

21. Interrupt Controller

The interrupt control register is built in interrupt control, and is supported for all I/O of interrupt function. This register set corresponding peripheral interrupt level.

(1) Register List

Interrupt control registers

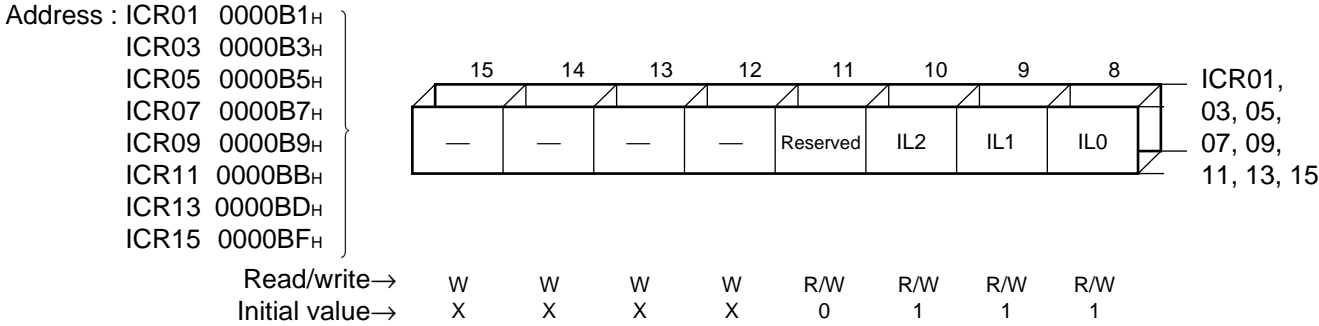

Interrupt control registers

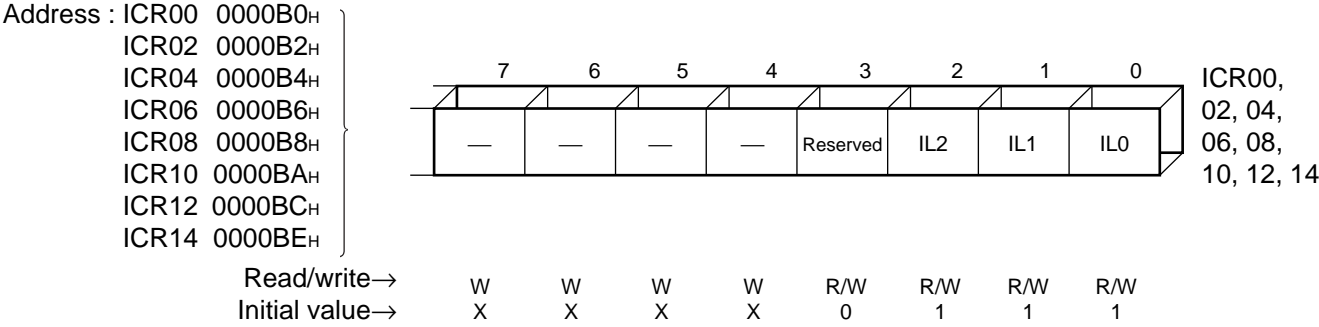

Note : The use of access involving read-modify-write instructions may lead to abnormal operation, and should be avoided.

MB90480/485 Series

(2) Block Diagram

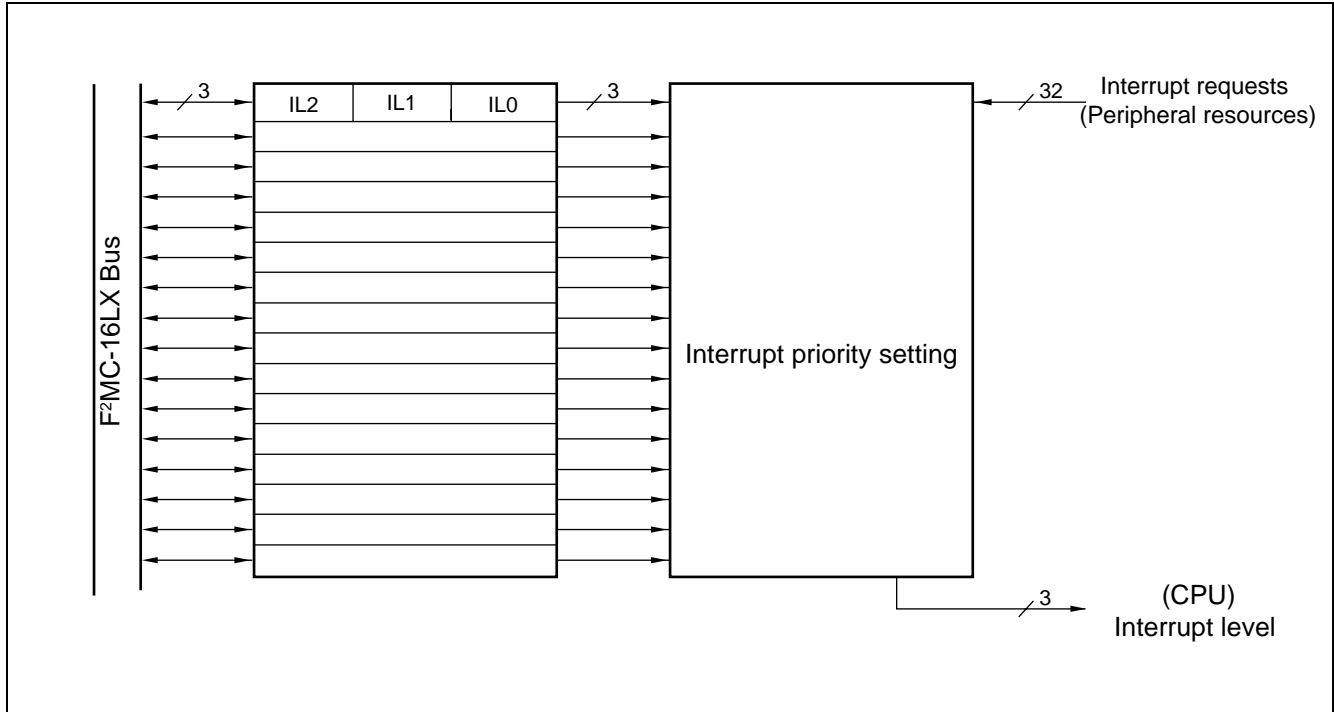

22. μ DMAC

The μ DMAC is a simplified DMA module with functions equivalent to EI²OS. The μ DMAC has 16 DMA data transfer channels, and provides the following functions.

- Automatic data transfer between peripheral resources (I/O) and memory.
- CPU program execution stops during DMA operation.
- Incremental addressing for transfer source and destination can be turned on and off.
- DMA transfer control from the μ DMAC enable register, μ DMAC stop status register, μ DMAC status register, and descriptor.
- Stop requests from resources can stop DMA transfer.
- When DMA transfer is completed, the μ DMAC status register sets a flag in the bit for the corresponding channel on which transfer was completed, and outputs a completion interrupt to the interrupt controller.

(1) Register List

μ DMAC enable register			Initial value																							
DERH : 0000AD _H	<table border="1"> <tr> <td>15</td><td>14</td><td>13</td><td>12</td><td>11</td><td>10</td><td>9</td><td>8</td> </tr> <tr> <td>EN15</td><td>EN14</td><td>EN13</td><td>EN12</td><td>EN11</td><td>EN10</td><td>EN9</td><td>EN8</td> </tr> <tr> <td>R/W</td><td>R/W</td><td>R/W</td><td>R/W</td><td>R/W</td><td>R/W</td><td>R/W</td><td>R/W</td> </tr> </table>	15	14	13	12	11	10	9	8	EN15	EN14	EN13	EN12	EN11	EN10	EN9	EN8	R/W	R/W	R/W	R/W	R/W	R/W	R/W	R/W	00000000 _B
15	14	13	12	11	10	9	8																			
EN15	EN14	EN13	EN12	EN11	EN10	EN9	EN8																			
R/W	R/W	R/W	R/W	R/W	R/W	R/W	R/W																			
μ DMAC enable register			Initial value																							
DERL : 0000AC _H	<table border="1"> <tr> <td>7</td><td>6</td><td>5</td><td>4</td><td>3</td><td>2</td><td>1</td><td>0</td> </tr> <tr> <td>EN7</td><td>EN6</td><td>EN5</td><td>EN4</td><td>EN3</td><td>EN2</td><td>EN1</td><td>EN0</td> </tr> <tr> <td>R/W</td><td>R/W</td><td>R/W</td><td>R/W</td><td>R/W</td><td>R/W</td><td>R/W</td><td>R/W</td> </tr> </table>	7	6	5	4	3	2	1	0	EN7	EN6	EN5	EN4	EN3	EN2	EN1	EN0	R/W	R/W	R/W	R/W	R/W	R/W	R/W	R/W	00000000 _B
7	6	5	4	3	2	1	0																			
EN7	EN6	EN5	EN4	EN3	EN2	EN1	EN0																			
R/W	R/W	R/W	R/W	R/W	R/W	R/W	R/W																			
μ DMAC stop status register			Initial value																							
DSSR : 0000A4 _H	<table border="1"> <tr> <td>7</td><td>6</td><td>5</td><td>4</td><td>3</td><td>2</td><td>1</td><td>0</td> </tr> <tr> <td>STP7</td><td>STP6</td><td>STP5</td><td>STP4</td><td>STP3</td><td>STP2</td><td>STP1</td><td>STP0</td> </tr> <tr> <td>R/W</td><td>R/W</td><td>R/W</td><td>R/W</td><td>R/W</td><td>R/W</td><td>R/W</td><td>R/W</td> </tr> </table>	7	6	5	4	3	2	1	0	STP7	STP6	STP5	STP4	STP3	STP2	STP1	STP0	R/W	R/W	R/W	R/W	R/W	R/W	R/W	R/W	00000000 _B
7	6	5	4	3	2	1	0																			
STP7	STP6	STP5	STP4	STP3	STP2	STP1	STP0																			
R/W	R/W	R/W	R/W	R/W	R/W	R/W	R/W																			
μ DMAC status register			Initial value																							
DSRH : 00009D _H	<table border="1"> <tr> <td>15</td><td>14</td><td>13</td><td>12</td><td>11</td><td>10</td><td>9</td><td>8</td> </tr> <tr> <td>DE15</td><td>DE14</td><td>DE13</td><td>DE12</td><td>DE11</td><td>DE10</td><td>DE9</td><td>DE8</td> </tr> <tr> <td>R/W</td><td>R/W</td><td>R/W</td><td>R/W</td><td>R/W</td><td>R/W</td><td>R/W</td><td>R/W</td> </tr> </table>	15	14	13	12	11	10	9	8	DE15	DE14	DE13	DE12	DE11	DE10	DE9	DE8	R/W	R/W	R/W	R/W	R/W	R/W	R/W	R/W	00000000 _B
15	14	13	12	11	10	9	8																			
DE15	DE14	DE13	DE12	DE11	DE10	DE9	DE8																			
R/W	R/W	R/W	R/W	R/W	R/W	R/W	R/W																			
μ DMAC status register			Initial value																							
DSRL : 00009C _H	<table border="1"> <tr> <td>7</td><td>6</td><td>5</td><td>4</td><td>3</td><td>2</td><td>1</td><td>0</td> </tr> <tr> <td>DE7</td><td>DE6</td><td>DE5</td><td>DE4</td><td>DE3</td><td>DE2</td><td>DE1</td><td>DE0</td> </tr> <tr> <td>R/W</td><td>R/W</td><td>R/W</td><td>R/W</td><td>R/W</td><td>R/W</td><td>R/W</td><td>R/W</td> </tr> </table>	7	6	5	4	3	2	1	0	DE7	DE6	DE5	DE4	DE3	DE2	DE1	DE0	R/W	R/W	R/W	R/W	R/W	R/W	R/W	R/W	00000000 _B
7	6	5	4	3	2	1	0																			
DE7	DE6	DE5	DE4	DE3	DE2	DE1	DE0																			
R/W	R/W	R/W	R/W	R/W	R/W	R/W	R/W																			

MB90480/485 Series

(2) Block Diagram

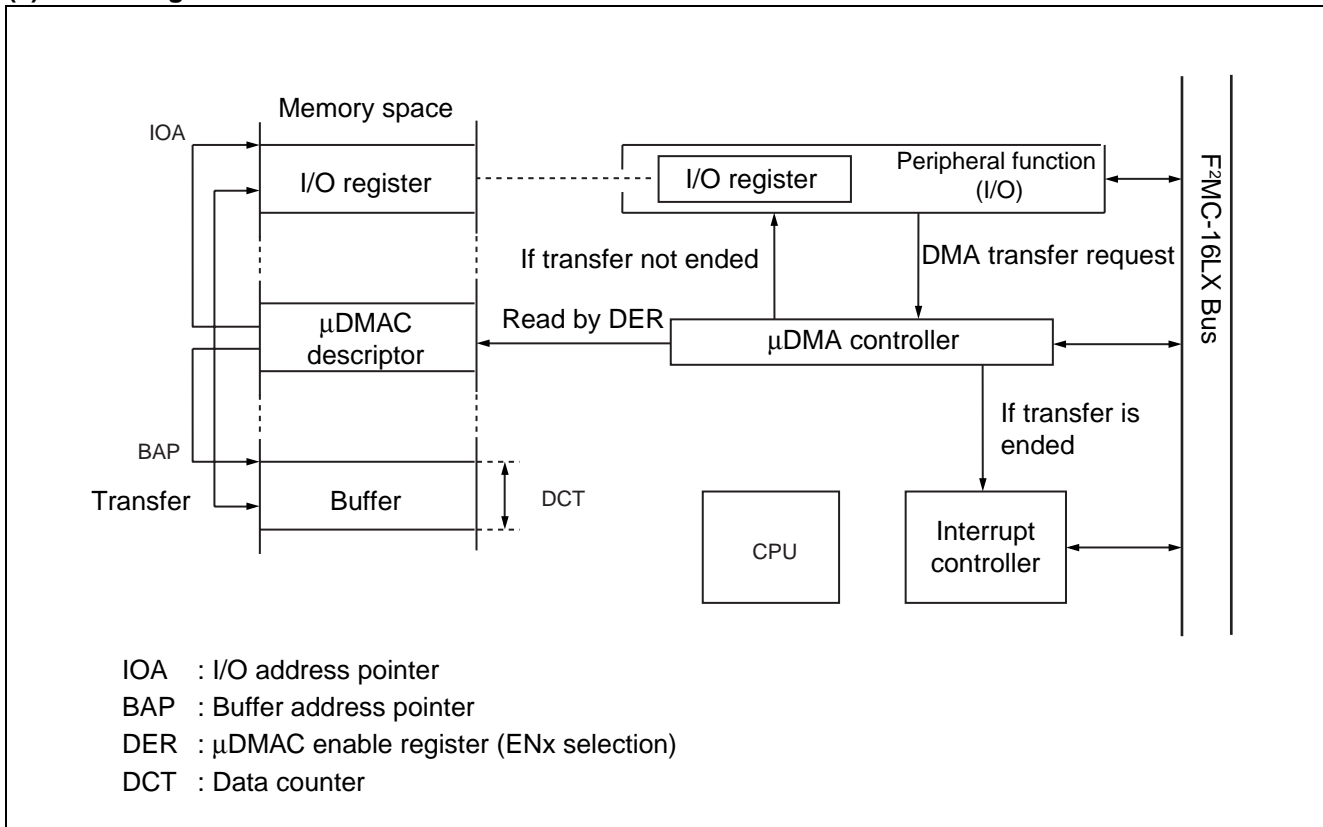

23. Address Match Detection Function

When the address is equal to a value set in the address detection register, the instruction code loaded into the CPU is replaced forcibly with the INT9 instruction code (01H). As a result, when the CPU executes a set instruction, the INT9 instruction is executed. Processing by the INT#9 interrupt routine allows the program patching function to be implemented.

Two address detection registers are supported. An interrupt enable bit is prepared for each register. If the value set in the address detection register matches an address and if the interrupt enable bit is set at "1", the instruction code loaded into the CPU is replaced forcibly with the INT9 instruction code.

(1) Register Configuration

- Program address detection register 0 (PADR0)

PADR0 (Low order address) : 001FF0H	Address	7	6	5	4	3	2	1	0	Initial value XXXXXXXX _B
		R/W	R/W	R/W	R/W	R/W	R/W	R/W	R/W	

PADR0 (Middle order address) : 001FF1H	Address	7	6	5	4	3	2	1	0	Initial value XXXXXXXX _B
		R/W	R/W	R/W	R/W	R/W	R/W	R/W	R/W	

PADR0 (High order address) : 001FF2H	Address	7	6	5	4	3	2	1	0	Initial value XXXXXXXX _B
		R/W	R/W	R/W	R/W	R/W	R/W	R/W	R/W	

- Program address detection register 1 (PADR1)

PADR1 (Low order address) : 001FF3H	Address	7	6	5	4	3	2	1	0	Initial value XXXXXXXX _B
		R/W	R/W	R/W	R/W	R/W	R/W	R/W	R/W	

PADR1 (Middle order address) : 001FF4H	Address	7	6	5	4	3	2	1	0	Initial value XXXXXXXX _B
		R/W	R/W	R/W	R/W	R/W	R/W	R/W	R/W	

PADR1 (High order address) : 001FF5H	Address	7	6	5	4	3	2	1	0	Initial value XXXXXXXX _B
		R/W	R/W	R/W	R/W	R/W	R/W	R/W	R/W	

- Program address detection control status register (PACSR)

00009EH	Address	7	6	5	4	3	2	1	0	Initial value 00000000 _B
		RESV	RESV	RESV	RESV	AD1E	RESV	AD0E	RESV	
		R/W	R/W	R/W	R/W	R/W	R/W	R/W	R/W	

R/W : Readable and writable
 X : Undefined
 RESV : Reserved bit

MB90480/485 Series

(2) Block Diagram

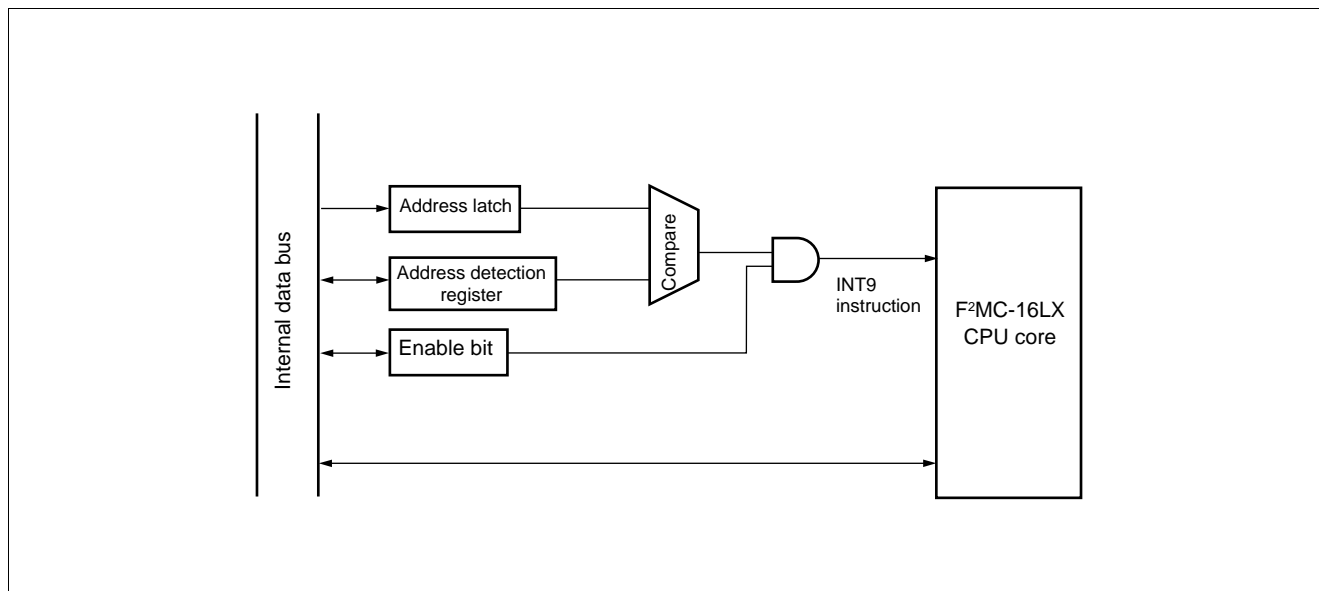

■ ELECTRICAL CHARACTERISTICS

1. Absolute Maximum Ratings

Parameter	Symbol	Rating		Unit	Remarks
		Min	Max		
Power supply voltage*1	V _{CC3}	V _{SS} - 0.3	V _{SS} + 4.0	V	
	V _{CC5}	V _{SS} - 0.3	V _{SS} + 7.0	V	
	AV _{CC}	V _{SS} - 0.3	V _{SS} + 4.0	V	*2
	AV _{RH}	V _{SS} - 0.3	V _{SS} + 4.0	V	
Input voltage*1	V _I	V _{SS} - 0.3	V _{SS} + 4.0	V	*3
		V _{SS} - 0.3	V _{SS} + 7.0	V	*3, *8, *9
Output volatage*1	V _O	V _{SS} - 0.3	V _{SS} + 4.0	V	*3
		V _{SS} - 0.3	V _{SS} + 7.0	V	*3, *8, *9
Maximum clamp current	I _{CLAMP}	-2.0	+2.0	mA	*7
Total maximum clamp current	$\sum I_{CLAMP} $	—	20	mA	*7
“L” level maximum output current	I _{OL}	—	10	mA	*4
“L” level average output current	I _{OLAV}	—	3	mA	*5
“L” level maximum total output current	$\sum I_{OL}$	—	60	mA	
“L” level total average output current	$\sum I_{OLAV}$	—	30	mA	*6
“H” level maximum output current	I _{OH}	—	-10	mA	*4
“H” level average output current	I _{OHAV}	—	-3	mA	*5
“H” level maximum total output current	$\sum I_{OH}$	—	-60	mA	
“H” level total average output current	$\sum I_{OHAV}$	—	-30	mA	*6
Power consumption	P _D	—	320	mW	
Operating temperature	T _A	-40	+85	°C	
Storage temperature	T _{stg}	-55	+150	°C	

*1 : This parameter is based on V_{SS} = AV_{SS} = 0.0 V.

*2 : AV_{CC} and AV_{RH} must not exceed V_{CC}. Also, AV_{RH} must not exceed AV_{CC}.

*3 : V_I and V_O must not exceed V_{CC} + 0.3 V. However, if the maximum current to/from and input is limited by some means with external components, the I_{CLAMP} rating supersedes the V_I rating.

*4 : Maximum output current is defined as the peak value for one of the corresponding pins.

*5 : Average output current is defined as the average current flow in a 100 ms interval at one of the corresponding pins.

*6 : Average total output current is defined as the average current flow in a 100 ms interval at all corresponding pins.

*7 : • Applicable to pins : P00 to P07, P10 to P17, P20 to P27, P30 to P37, P40 to P46, P60 to P67, P70 to P77, P80 to P87, P90 to P97, PA0 to PA3

- Use within recommended operating conditions.
- Use at DC voltage (current) .
- The +B signal should always be applied with a limiting resistance placed between the +B signal and the microcontroller.
- The value of the limiting resistance should be set so that when the +B signal is applied the input current to the microcontroller pin does not exceed rated values, either instantaneously or for prolonged periods.

MB90480/485 Series

- Note that when the microcontroller drive current is low, such as in the power saving modes, the +B input potential may pass through the protective diode and increase the potential at the V_{CC} pin, and this may affect other devices.
- Note that if a +B signal is input when the microcontroller current is off (not fixed at 0 V), the power supply is provided from the pins, so that incomplete operation may result.
- Note that if the +B input is applied during power-on, the power supply is provided from the pins and the resulting supply voltage may not be sufficient to operate the power-on reset.
- Care must be taken not to leave the +B input pin open.
- Note that analog system input/output pins other than the A/D input pins (LCD drive pins, comparator input pins, etc.) cannot accept +B signal input.
- Sample recommended circuits:

- Input/Output Equivalent circuits

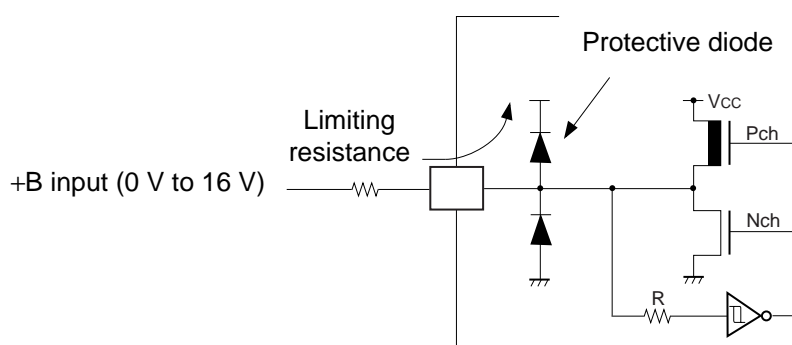

*8 : MB90485 series only

P20 to P27, P30 to P37, P40 to P47, P70 to P77 pins can be used as 5 V I/F pin on applied 5 V to V_{CC5} pin.
P76 and P77 is Nch open drain pin.

*9 : As for P76 and P77 (Nch open drain pin), even if using at 3 V simplicity (V_{CC3} = V_{CC5}), the ratings are applied.

WARNING: Semiconductor devices can be permanently damaged by application of stress (voltage, current, temperature, etc.) in excess of absolute maximum ratings. Do not exceed these ratings.

2. Recommended Operating Conditions

($V_{SS} = AV_{SS} = 0.0\text{ V}$)

Parameter	Symbol	Value		Unit	Remarks
		Min	Max		
Supply voltage	V_{CC3}	2.7	3.6	V	During normal operation
		1.8	3.6	V	To maintain RAM state in stop mode
	V_{CC5}	2.7	5.5	V	During normal operation*
		1.8	5.5	V	To maintain RAM state in stop mode*
“H” level input voltage	V_{IH}	$0.7 V_{CC}$	$V_{CC} + 0.3$	V	All pins other than V_{IH2} , V_{IHS} , V_{IHM} and V_{IHx}
	V_{IH2}	$0.7 V_{CC}$	$V_{SS} + 5.8$	V	MB90485 series only P76, P77 pins (Nch open drain pins)
	V_{IHS}	$0.8 V_{CC}$	$V_{CC} + 0.3$	V	Hysteresis input pins
	V_{IHM}	$V_{CC} - 0.3$	$V_{CC} + 0.3$	V	MD pin input
	V_{IHx}	$0.8 V_{CC}$	$V_{CC} + 0.3$	V	X0A pin, X1A pin
“L” level input voltage	V_{IL}	$V_{SS} - 0.3$	$0.3 V_{CC}$	V	All pins other than V_{ILS} , V_{ILM} and V_{ILx}
	V_{ILS}	$V_{SS} - 0.3$	$0.2 V_{CC}$	V	Hysteresis input pins
	V_{ILM}	$V_{SS} - 0.3$	$V_{SS} + 0.3$	V	MD pin input
	V_{ILx}	$V_{SS} - 0.3$	0.1	V	X0A pin, X1A pin
Operating temperature	T_A	-40	+85	°C	

* : MB90485 series only

P20 to P27, P30 to P37, P40 to P47, P70 to P77 pins can be used as 5 V I/F pin on applied 5 V to V_{CC5} pin.

WARNING: The recommended operating conditions are required in order to ensure the normal operation of the semiconductor device. All of the device's electrical characteristics are warranted when the device is operated within these ranges.

Always use semiconductor devices within their recommended operating condition ranges. Operation outside these ranges may adversely affect reliability and could result in device failure.

No warranty is made with respect to uses, operating conditions, or combinations not represented on the data sheet. Users considering application outside the listed conditions are advised to contact their FUJITSU representatives beforehand.

MB90480/485 Series

3. DC Characteristics

($V_{CC} = 2.7\text{ V to }3.6\text{ V}$, $V_{SS} = 0.0\text{ V}$, $T_A = -40\text{ }^\circ\text{C to }+85\text{ }^\circ\text{C}$)

Parameter	Symbol	Pin name	Condition	Value			Unit	Remarks
				Min	Typ	Max		
“H” level output voltage	V_{OH}	All output pins	$V_{CC} = 2.7\text{ V}$, $I_{OH} = -1.6\text{ mA}$	$V_{CC3} - 0.3$	—	—	V	
			$V_{CC} = 4.5\text{ V}$, $I_{OH} = -4.0\text{ mA}$	$V_{CC5} - 0.5$	—	—	V	At using 5 V power supply
“L” level output voltage	V_{OL}	All output pins	$V_{CC} = 2.7\text{ V}$, $I_{OL} = 2.0\text{ mA}$	—	—	0.4	V	
			$V_{CC} = 4.5\text{ V}$, $I_{OH} = 4.0\text{ mA}$	—	—	0.4	V	At using 5 V power supply
Input leakage current	I_{IL}	All input pins	$V_{CC} = 3.3\text{ V}$, $V_{SS} < V_I < V_{CC}$	-10	—	+10	μA	
Pull-up resistance	RPULL	—	$V_{CC} = 3.0\text{ V}$, at $T_A = +25\text{ }^\circ\text{C}$	20	53	200	$\text{k}\Omega$	
Open drain output current	I_{leak}	P40 to P47, P70 to P77	—	—	0.1	10	μA	
Power supply current	I_{CC}	—	At $V_{CC} = 3.3\text{ V}$, internal 25 MHz operation, normal operation	—	45	60	mA	
			At $V_{CC} = 3.3\text{ V}$, internal 25 MHz operation, FLASH programming	—	55	70	mA	
	I_{CCS}	—	At $V_{CC} = 3.3\text{ V}$, internal 25 MHz operation, sleep mode	—	17	35	mA	
	I_{CCL}	—	At $V_{CC} = 3.3\text{ V}$, external 32 kHz, internal 8 kHz operation, sub clock operation ($T_A = +25\text{ }^\circ\text{C}$)	—	15	140	μA	
	I_{CCT}	—	At $V_{CC} = 3.3\text{ V}$, external 32 kHz, internal 8 kHz operation, watch mode ($T_A = +25\text{ }^\circ\text{C}$)	—	1.8	40	μA	
	I_{CCH}	—	$T_A = +25\text{ }^\circ\text{C}$, stop mode, At $V_{CC} = 3.3\text{ V}$	—	0.8	40	μA	
Input capacitance	C_{IN}	Other than AV_{CC} , AV_{SS} , V_{CC} , V_{SS}	—	—	5	15	pF	

- Notes :
- Pins P40 to P47, and P70 to P77 are controlled Nch open drain pins, and should always be used at CMOS levels.
 - MB90485 series only
 - P40 to P47 and P70 to P77 are Nch open drain pins with control, which are usually used as CMOS.
 - P76 and P77 are open drain pins without Pch.
 - For use as a single 3 V power supply products, set $V_{CC} = V_{CC3} = V_{CC5}$.
 - When the device is used with dual power supplies, P20 to P27, P30 to P37, P40 to P47 and P70 to P77 serve as 5 V pins while the other pins serve as 3 V I/O pins.

4. AC Characteristics

(1) Clock Timing

($V_{SS} = 0.0 \text{ V}$, $T_A = -40 \text{ }^\circ\text{C}$ to $+85 \text{ }^\circ\text{C}$)

Parameter	Symbol	Pinname	Condition	Value			Unit	Remarks
				Min	Typ	Max		
Clock frequency	F _{CH}	X0, X1	—	3	—	25	MHz	External crystal oscillator
			—	3	—	50		External clock input
			—	4	—	25		1 multiplied PLL
			—	3	—	12.5		2 multiplied PLL
			—	3	—	6.66		3 multiplied PLL
			—	3	—	6.25		4 multiplied PLL
			—	3	—	4.16		6 multiplied PLL
			—	3	—	3.12		8 multiplied PLL
	F _{CL}	X0A, X1A	—	—	32.768	—	kHz	
Clock cycle time	t _c	X0, X1	—	20	—	333	ns	*1
	t _{CL}	X0A, X1A	—	—	30.5	—	μs	
Input clock pulse width	P _{WH} P _{WL}	X0	—	5	—	—	ns	
	P _{WLH} P _{WLL}	X0A	—	—	15.2	—	μs	*2
Input clock rise, fall time	t _{cr} t _{cf}	X0	—	—	—	5	ns	With external clock
Internal operating clock frequency	f _{CP}	—	—	1.5	—	25	MHz	*1
	f _{CPL}	—	—	—	8.192	—	kHz	
Internal operating clock cycle time	t _{CP}	—	—	40.0	—	666	ns	*1
	t _{CPL}	—	—	—	122.1	—	μs	

*1 : Be careful of the operating voltage.

*2 : Duty ratio should be 50 % ± 3 %.

MB90480/485 Series

- X0, X1 clock timing

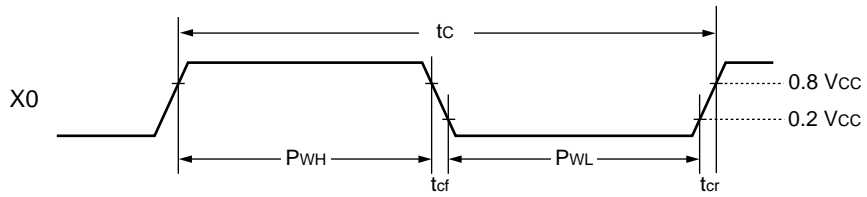

- X0A, X1A clock timing

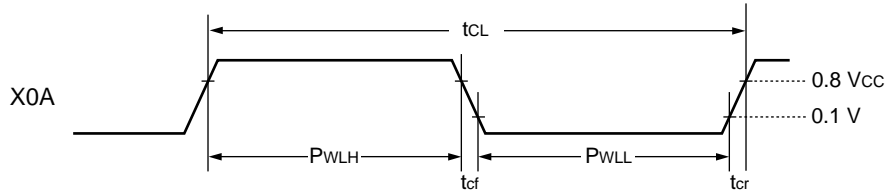

• Range of warranted PLL operation

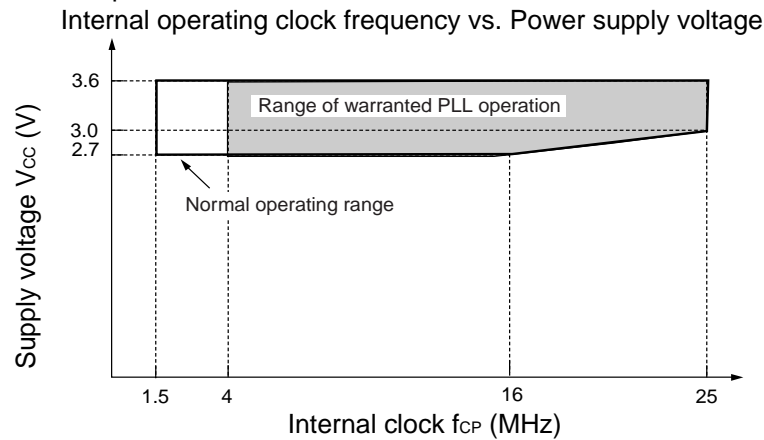

- Notes:
- For A/D operating frequency, refer to “5. A/D Converter Electrical Characteristics”
 - Only at 1 multiplied PLL, use with more than $f_{CP} = 4$ MHz.

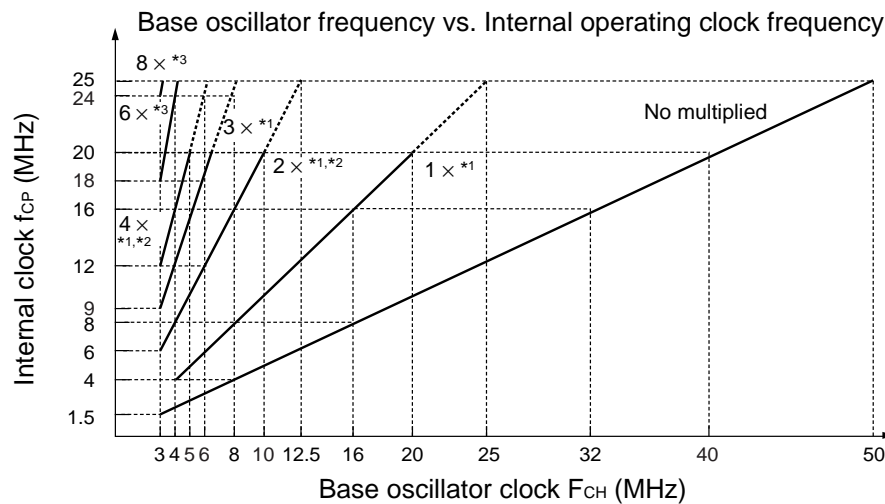

*1 : In setting as 1, 2, 3 and 4 multiplied PLL, when the internal clock is used at $20 \text{ MHz} < f_{CP} \leq 25 \text{ MHz}$, set the PLLOS register to “DIV2 bit = 1” and “PLL2 bit = 1”.

[Example] When using the base oscillator frequency of 24 MHz at 1 multiplied PLL :

CKSCR register : CS1 bit = “0”, CS0 bit = “0” PLLOS register : DIV2 bit = “1”, PLL2 bit = “1”

[Example] When using the base oscillator frequency of 6 MHz at 3 multiplied PLL :

CKSCR register : CS1 bit = “1”, CS0 bit = “0” PLLOS register : DIV2 bit = “1”, PLL2 bit = “1”

*2 : In setting as 2 and 4 multiplied PLL, when the internal clock is used at $20 \text{ MHz} < f_{CP} \leq 25 \text{ MHz}$, the following setting is also enabled.

2 multiplied PLL : CKSCR register : CS1 bit = “0”, CS0 bit = “0”

PLLOS register : DIV2 bit = “0”, PLL2 bit = “1”

4 multiplied PLL : CKSCR register : CS1 bit = “0”, CS0 bit = “1”

PLLOS register : DIV2 bit = “0”, PLL2 bit = “1”

*3 : When using in setting as 6 and 8 multiplied PLL, set the PLLOS register to “DIV2 bit = 0” and “PLL2 bit = 1”.

[Example] When using the base oscillator frequency of 4 MHz at 6 multiplied PLL :

CKSCR register : CS1 bit = “1”, CS0 bit = “0” PLLOS register : DIV2 bit = “0”, PLL2 bit = “1”

[Example] When using the base oscillator frequency of 3 MHz at 8 multiplied PLL :

CKSCR register : CS1 bit = “1”, CS0 bit = “1” PLLOS register : DIV2 bit = “0”, PLL2 bit = “1”

MB90480/485 Series

AC standards are set at the following measurement voltage values.

- Input signal waveform

Hysteresis input pins

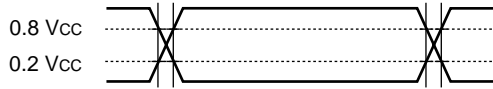

- Pins other than hysteresis input/MD input

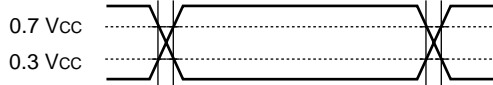

- Output signal waveform

Output pins

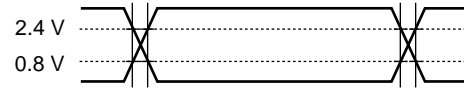

(2) Clock Output Timing

($V_{SS} = 0.0\text{ V}$, $T_A = -40\text{ }^\circ\text{C}$ to $+85\text{ }^\circ\text{C}$)

Parameter	Symbol	Pin name	Conditions	Value		Unit	Remarks
				Min	Max		
Cycle time	t_{CYC}	CLK	—	t_{CP}^*	—	ns	
CLK \uparrow →CLK \downarrow	t_{CHCL}	CLK	$V_{CC} = 3.0\text{ V}$ to 3.6 V	$t_{CP}^* / 2 - 15$	$t_{CP}^* / 2 + 15$	ns	at $f_{CP} = 25\text{ MHz}$
			$V_{CC} = 2.7\text{ V}$ to 3.3 V	$t_{CP}^* / 2 - 20$	$t_{CP}^* / 2 + 20$	ns	at $f_{CP} = 16\text{ MHz}$
			$V_{CC} = 2.7\text{ V}$ to 3.3 V	$t_{CP}^* / 2 - 64$	$t_{CP}^* / 2 + 64$	ns	at $f_{CP} = 5\text{ MHz}$

* : t_{CP} is internal operating clock cycle time. Refer to “(1) Clock Timing”.

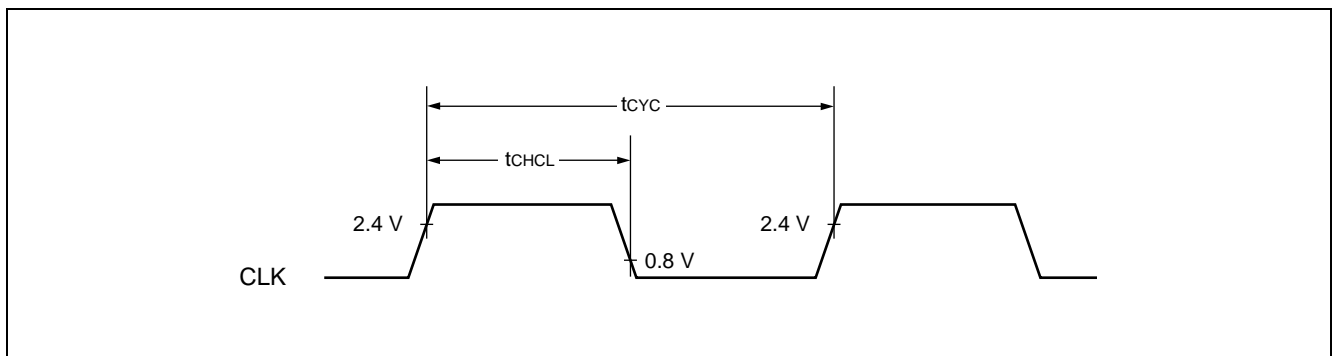

MB90480/485 Series

(3) Reset Input Standards

($V_{CC} = 2.7\text{ V to }3.6\text{ V}$, $V_{SS} = 0.0\text{ V}$, $T_A = -40\text{ }^\circ\text{C to }+85\text{ }^\circ\text{C}$)

Parameter	Symbol	Pin name	Conditions	Value		Unit	Remarks
				Min	Max		
Reset input time	t_{RSTL}	\overline{RST}	—	$16 t_{CP}^{*1}$	—	ns	Normal operation
				Oscillator oscillation time ^{*2} $+ 4 t_{CP}^{*1}$	—	ms	Stop mode

*1 : t_{CP} is internal operating clock cycle time. Refer to “ (1) Clock Timing”.

*2 : Oscillator oscillation time is the time to 90 % of amplitude. For a crystal oscillator this is on the order of several milliseconds to tens of milliseconds. For a FAR/ceramic oscillator, this is several hundred microseconds to several milliseconds. For an external clock signal the value is 0 ms.

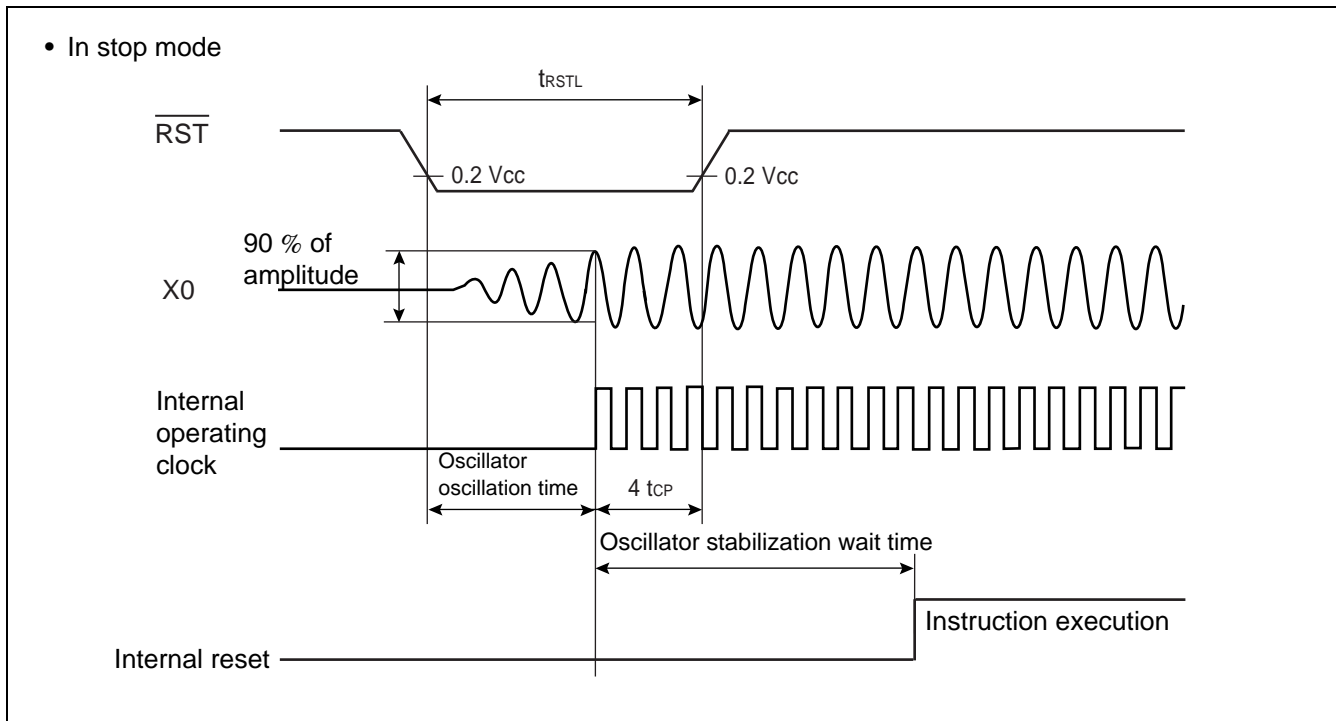

• Condition for measurement of AC standards

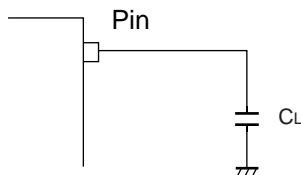

C_L : Load capacitance applied during testing
 CLK, ALE : $C_L = 30\text{ pF}$
 AD15 to AD00 (address data bus) , \overline{RD} , \overline{WR} ,
 A23 to A00/D15 to D00 : $C_L = 30\text{ pF}$

(4) Power-on Reset Standards

($V_{CC} = 2.7\text{ V to }3.6\text{ V}$, $V_{SS} = 0.0\text{ V}$, $T_A = -40\text{ }^\circ\text{C to }+85\text{ }^\circ\text{C}$)

Parameter	Symbol	Pin name	Conditions	Value		Unit	Remarks
				Min	Max		
Power rise time	t_R	V_{CC}	—	—	30	ms	*
Power down time	t_{OFF}	V_{CC}	—	1	—	ms	In repeated operation

* : Power rise time requires $V_{CC} < 0.2\text{ V}$.

Notes: • The above standards are for the application of a power-on reset.

- Within the device, the power-on reset should be applied by switching the power supply off and on again.

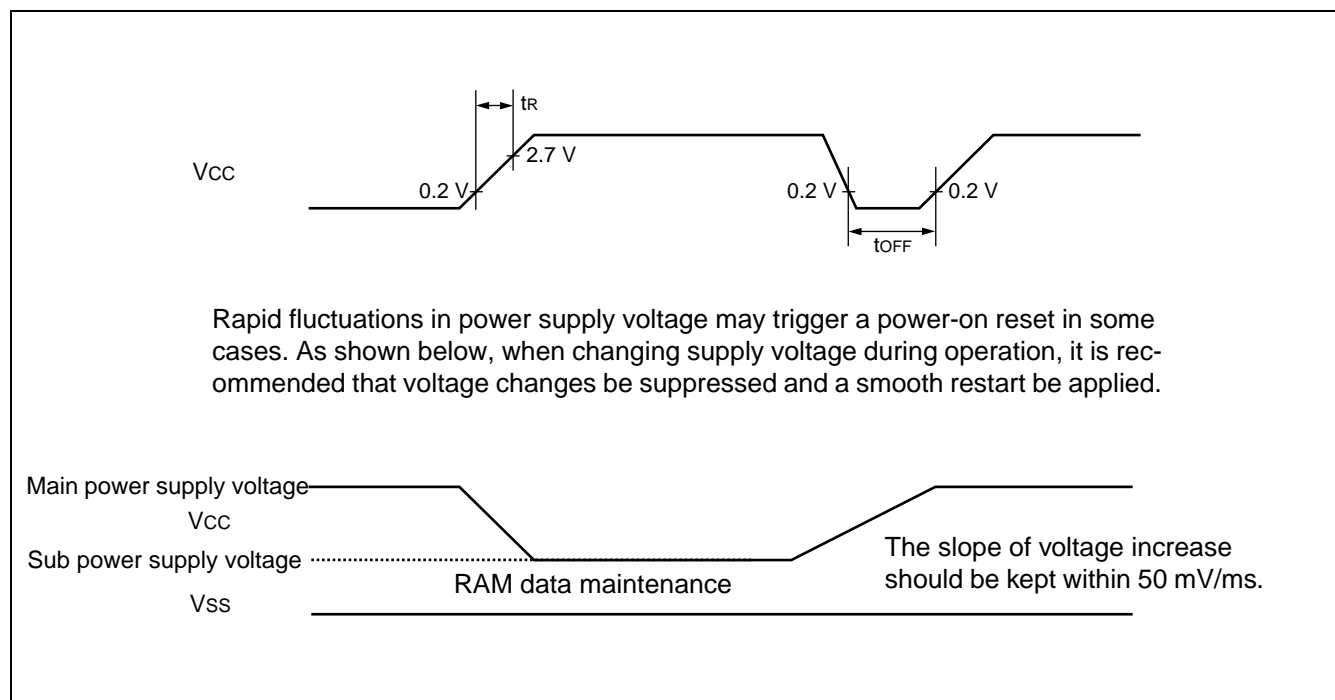

MB90480/485 Series

(5) Bus Read Timing

($V_{CC} = 2.7\text{ V to }3.6\text{ V}$, $V_{SS} = 0.0\text{ V}$, $T_A = 0\text{ }^\circ\text{C to }+70\text{ }^\circ\text{C}$)

Parameter	Symbol	Pin name	Conditions	Value		Unit	Remarks
				Min	Max		
ALE pulse width	t_{LHLL}	ALE	—	$t_{CP}^* / 2 - 15$	—	ns	$16\text{ MHz} < f_{CP} \leq 25\text{ MHz}$
				$t_{CP}^* / 2 - 20$	—	ns	$8\text{ MHz} < f_{CP} \leq 16\text{ MHz}$
				$t_{CP}^* / 2 - 35$	—	ns	$f_{CP} \leq 8\text{ MHz}$
Valid address→ ALE↓time	t_{AVLL}	Address, ALE	—	$t_{CP}^* / 2 - 17$	—	ns	
				$t_{CP}^* / 2 - 40$	—	ns	$f_{CP} \leq 8\text{ MHz}$
ALE↓→ address valid time	t_{LLAX}	ALE, Address	—	$t_{CP}^* / 2 - 15$	—	ns	
Valid address→ \overline{RD} ↓time	t_{AVRL}	\overline{RD} , address	—	$t_{CP}^* - 25$	—	ns	
Valid address→ valid data input	t_{AVDV}	Address, Data	—	—	$5 t_{CP}^* / 2 - 55$	ns	
				—	$5 t_{CP}^* / 2 - 80$	ns	$f_{CP} \leq 8\text{ MHz}$
\overline{RD} pulse width	t_{RLRH}	\overline{RD}	—	$3 t_{CP}^* / 2 - 25$	—	ns	$16\text{ MHz} < f_{CP} \leq 25\text{ MHz}$
				$3 t_{CP}^* / 2 - 20$	—	ns	$8\text{ MHz} < f_{CP} \leq 16\text{ MHz}$
\overline{RD} ↓→ valid data input	t_{RLDV}	\overline{RD} , Data	—	—	$3 t_{CP}^* / 2 - 55$	ns	
				—	$3 t_{CP}^* / 2 - 80$	ns	$f_{CP} \leq 8\text{ MHz}$
\overline{RD} ↑→data hold time	t_{RHDX}	\overline{RD} , Data	—	0	—	ns	
\overline{RD} ↑→ALE↑rise time	$t_{RH LH}$	\overline{RD} , ALE	—	$t_{CP}^* / 2 - 15$	—	ns	
\overline{RD} ↑→ address valid time	t_{RHAX}	Address, \overline{RD}	—	$t_{CP}^* / 2 - 10$	—	ns	
Valid address→ CLK↑time	t_{AVCH}	Address, CLK	—	$t_{CP}^* / 2 - 17$	—	ns	
\overline{RD} ↓→CLK↑time	t_{RLCH}	\overline{RD} , CLK	—	$t_{CP}^* / 2 - 17$	—	ns	
ALE↓→ \overline{RD} ↓time	t_{LLRL}	\overline{RD} , ALE	—	$t_{CP}^* / 2 - 15$	—	ns	

* : t_{CP} is internal operating clock cycle time. Refer to “(1) Clock Timing”.

MB90480/485 Series

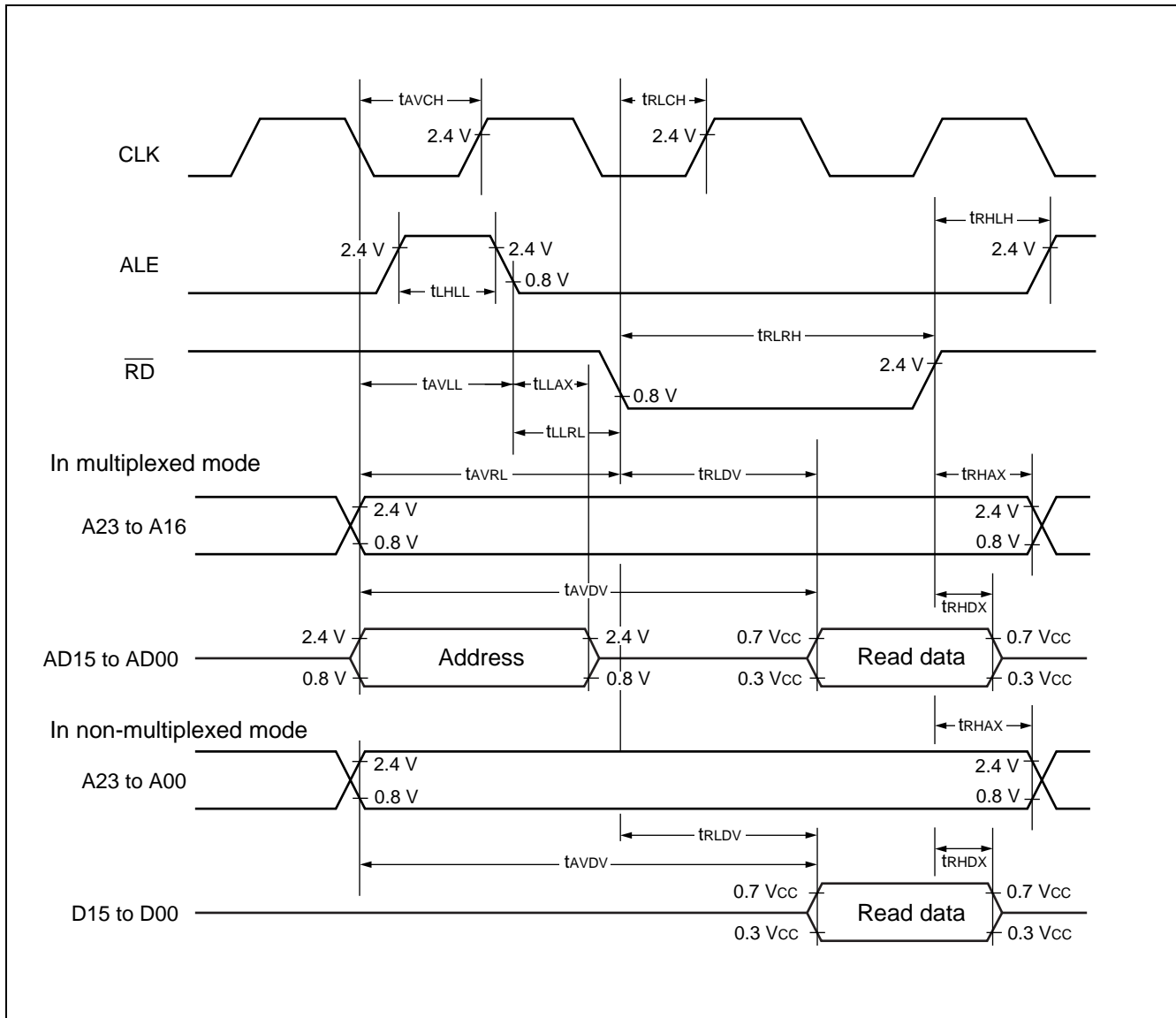

MB90480/485 Series

(6) Bus Write Timing

($V_{CC} = 2.7\text{ V to }3.6\text{ V}$, $V_{SS} = 0.0\text{ V}$, $T_A = 0\text{ }^{\circ}\text{C to }+70\text{ }^{\circ}\text{C}$)

Parameter	Symbol	Pin name	Condition	Value		Unit	Remarks
				Min	Max		
Valid address $\rightarrow \overline{\text{WR}} \downarrow$ time	t_{AVWL}	Address, $\overline{\text{WR}}$	—	$t_{CP}^* - 15$	—	ns	
$\overline{\text{WR}}$ pulse width	t_{WLWH}	$\overline{\text{WRL}}$, $\overline{\text{WRH}}$	—	$3 t_{CP}^* / 2 - 25$	—	ns	$16\text{ MHz} < f_{CP} \leq 25\text{ MHz}$
			—	$3 t_{CP}^* / 2 - 20$	—	ns	$8\text{ MHz} < f_{CP} \leq 16\text{ MHz}$
Valid data output $\rightarrow \overline{\text{WR}} \uparrow$ time	t_{DVWH}	Data, $\overline{\text{WR}}$	—	$3 t_{CP}^* / 2 - 15$	—	ns	
$\overline{\text{WR}} \uparrow \rightarrow$ data hold time	t_{WHDX}	$\overline{\text{WR}}$, Data	—	10	—	ns	$16\text{ MHz} < f_{CP} \leq 25\text{ MHz}$
			—	20	—	ns	$8\text{ MHz} < f_{CP} \leq 16\text{ MHz}$
			—	30	—	ns	$f_{CP} \leq 8\text{ MHz}$
$\overline{\text{WR}} \uparrow \rightarrow$ address valid time	t_{WHAX}	$\overline{\text{WR}}$, Address	—	$t_{CP}^* / 2 - 10$	—	ns	
$\overline{\text{WR}} \uparrow \rightarrow \text{ALE} \uparrow$ time	t_{WHLH}	$\overline{\text{WR}}$, ALE	—	$t_{CP}^* / 2 - 15$	—	ns	
$\overline{\text{WR}} \downarrow \rightarrow \text{CLK} \uparrow$ time	t_{WLCH}	$\overline{\text{WR}}$, CLK	—	$t_{CP}^* / 2 - 17$	—	ns	

* : t_{CP} is internal operating clock cycle time. Refer to “(1) Clock Timing”.

MB90480/485 Series

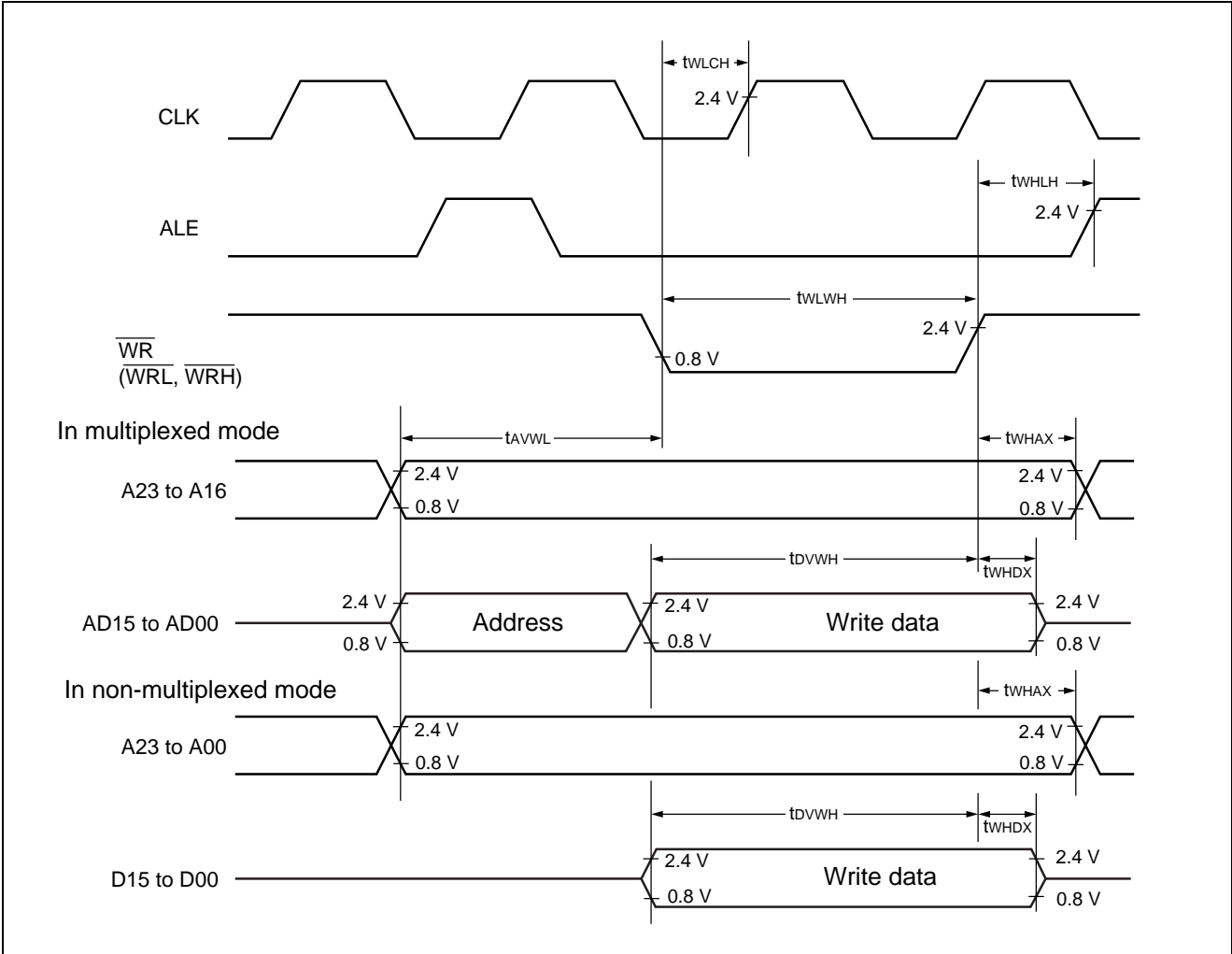

MB90480/485 Series

(7) Ready Input Timing

($V_{CC} = 2.7\text{ V}$ to 3.6 V , $V_{SS} = 0.0\text{ V}$, $T_A = 0\text{ }^{\circ}\text{C}$ to $+70\text{ }^{\circ}\text{C}$).

Parameter	Symbol	Pin name	Conditions	Value		Unit	Remarks
				Min	Max		
RDY setup time	t_{RYHS}	RDY	—	35	—	ns	at $f_{CP} = 8\text{ MHz}$
			—	70	—	ns	
RDY hold time	t_{RYHH}		—	0	—	ns	

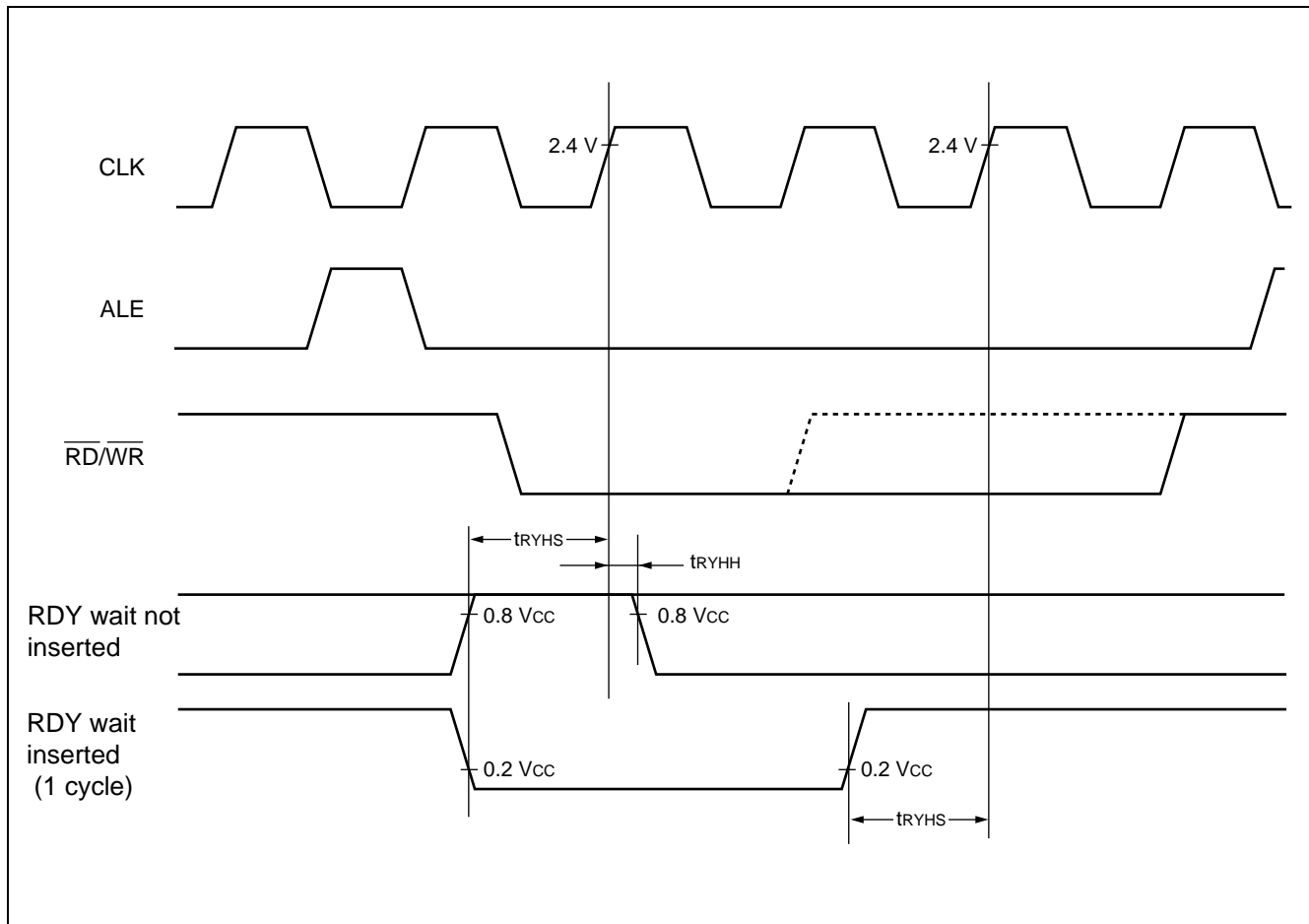

MB90480/485 Series

(8) Hold Timing

($V_{CC} = 2.7\text{ V to }3.6\text{ V}$, $V_{SS} = 0.0\text{ V}$, $T_A = 0\text{ }^\circ\text{C to }+70\text{ }^\circ\text{C}$)

Parameter	Symbol	Pin name	Conditions	Value		Unit	Remarks
				Min	Max		
Pin floating→ $\overline{\text{HAK}}\downarrow$ time	t_{XHAL}	$\overline{\text{HAK}}$	—	30	t_{CP}^*	ns	
$\overline{\text{HAK}}\downarrow$ →pin valid time	t_{HAHV}	$\overline{\text{HAK}}$	—	t_{CP}^*	$2 t_{CP}^*$	ns	

* : t_{CP} is internal operating clock cycle time. Refer to “(1) Clock Timing”.

Note : One or more cycles are required from the time the HRQ pin is read until the $\overline{\text{HAK}}$ signal changes.

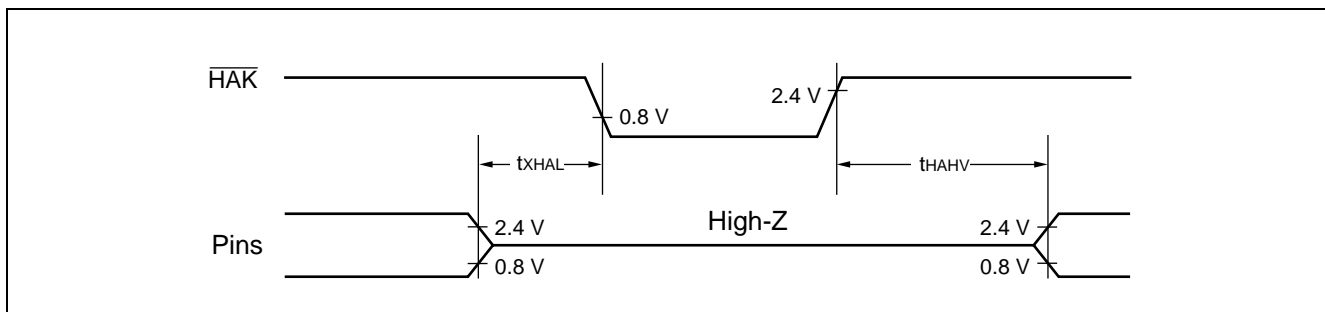

(9) UART Timing

($V_{CC} = 2.7\text{ V to }3.6\text{ V}$, $V_{SS} = 0.0\text{ V}$, $T_A = -40\text{ }^\circ\text{C to }+85\text{ }^\circ\text{C}$)

Parameter	Symbol	Pin	Conditions	Value		Unit	Remarks
				Min	Max		
Serial clock cycle time	t_{SCYC}	—	Internal shift clock mode output pins : $C_L^{*1} = 80\text{ pF} + 1\text{ TTL}$	$8 t_{CP}^{*2}$	—	ns	
SCK \downarrow →SOT delay time	t_{SLOV}	—		-80	+80	ns	$f_{CP} = 8\text{ MHz}$
Valid SIN→SCK \uparrow	t_{IVSH}	—		100	—	ns	
				200	—	ns	$f_{CP} = 8\text{ MHz}$
SCK \uparrow →valid SIN hold time	t_{SHIX}	—		t_{CP}^{*2}	—	ns	
Serial clock “H” pulse width	t_{SHSL}	—	External shift clock mode output pins : $C_L^{*1} = 80\text{ pF} + 1\text{ TTL}$	$4 t_{CP}^{*2}$	—	ns	
Serial clock “L” pulse width	t_{SLSH}	—		$4 t_{CP}^{*2}$	—	ns	
SCK \downarrow →SOT delay time	t_{SLOV}	—		—	150	ns	
				—	200	ns	$f_{CP} = 8\text{ MHz}$
Valid SIN→SCK \uparrow	t_{IVSH}	—		60	—	ns	
				120	—	ns	$f_{CP} = 8\text{ MHz}$
SCK \uparrow →valid SIN hold time	t_{SHIX}	—		60	—	ns	
				120	—	ns	$f_{CP} = 8\text{ MHz}$

*1 : C_L is the load capacitance applied to pins for testing.

*2 : t_{CP} is internal operating clock cycle time. Refer to “(1) Clock Timing”.

Note : AC ratings are for CLK synchronized mode.

MB90480/485 Series

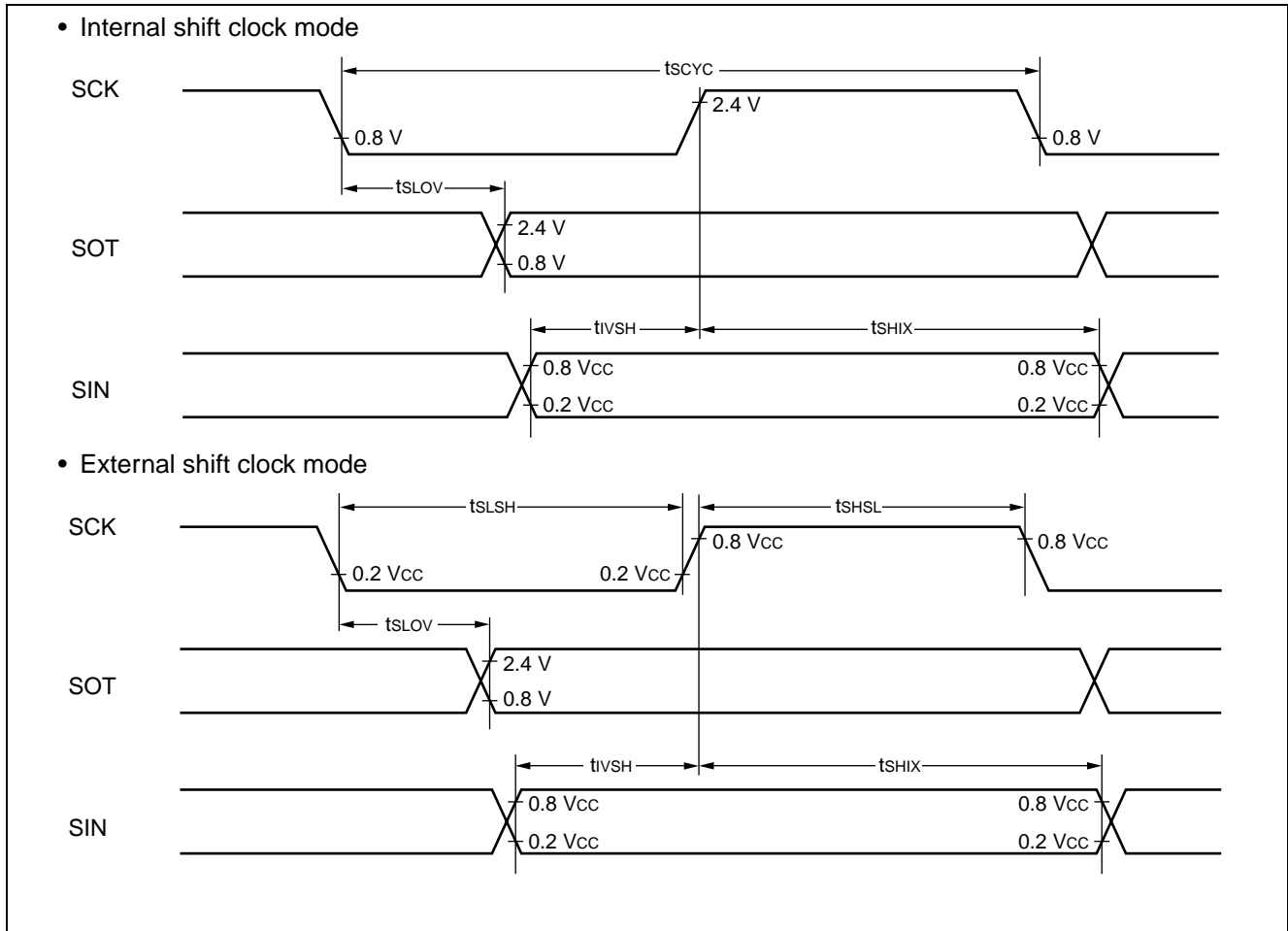

(10) Extended I/O serial interface Timing

($V_{CC} = 2.7\text{ V to }3.6\text{ V}$, $V_{SS} = 0.0\text{ V}$, $T_A = -40\text{ }^\circ\text{C to }+85\text{ }^\circ\text{C}$)

Parameter	Symbol	Pin name	Conditions	Value		Unit	Remarks
				Min	Max		
Serial clock cycle time	t_{SCYC}	—	Internal shift clock mode output pins : $C_L^{*1} = 80\text{ pF} + 1\text{ TTL}$	$8 t_{CP}^{*2}$	—	ns	
SCK↓→SOT delay time	t_{SLOV}	—		-80	+ 80	ns	
Valid SIN→SCK↑	t_{IVSH}	—		-120	+ 120	ns	$f_{CP} = 8\text{ MHz}$
SCK↑→valid SIN hold time	t_{SHIX}	—		100	—	ns	
				200	—	ns	$f_{CP} = 8\text{ MHz}$
Serial clock "H" pulse width	t_{SHSL}	—	External shift clock mode output pins : $C_L^{*1} = 80\text{ pF} + 1\text{ TTL}$	t_{CP}^{*2}	—	ns	
Serial clock "L" pulse width	t_{SLSH}	—		$4 t_{CP}^{*2}$	—	ns	
SCK↓→SOT delay time	t_{SLOV}	—		—	150	ns	
Valid SIN→SCK↑	t_{IVSH}	—		—	200	ns	$f_{CP} = 8\text{ MHz}$
				60	—	ns	
				120	—	ns	$f_{CP} = 8\text{ MHz}$
SCK↑→valid SIN hold time	t_{SHIX}	—		60	—	ns	
				120	—	ns	$f_{CP} = 8\text{ MHz}$

*1 : C_L is the load capacitance applied to pins for testing.

*2 : t_{CP} is internal operating clock cycle time. Refer to “ (1) Clock Timing”.

Notes : • AC ratings are for CLK synchronized mode.
• Values on this table are target values.

MB90480/485 Series

- Internal shift clock mode

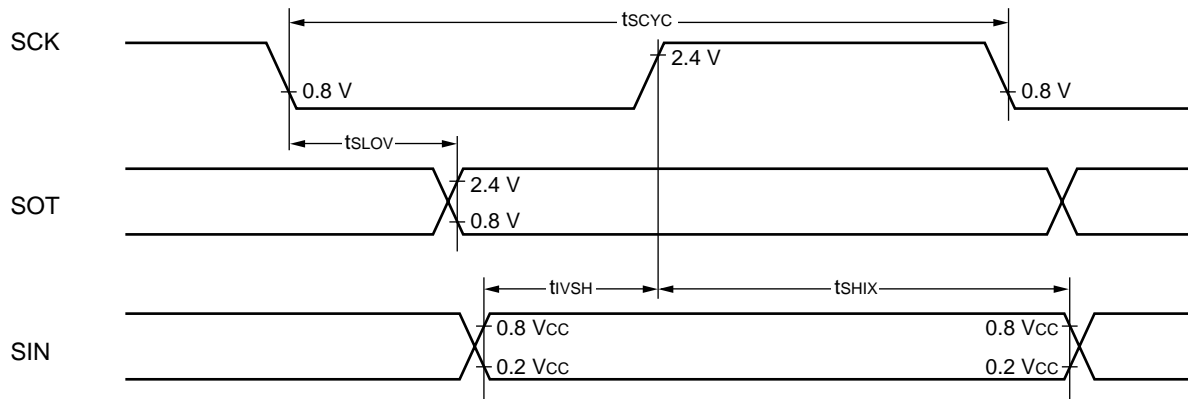

- External shift clock mode

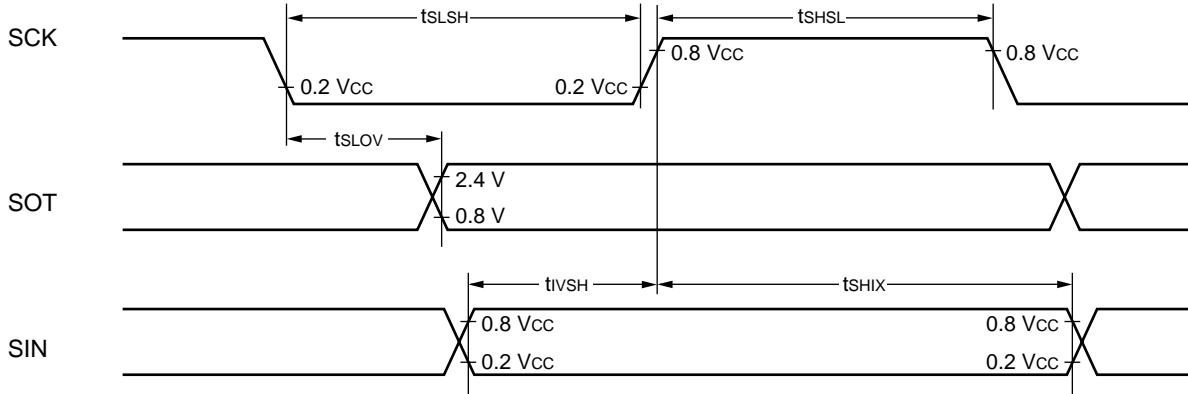

(11) Timer Input Timing

($V_{CC} = 2.7\text{ V to }3.6\text{ V}$, $V_{SS} = 0.0\text{ V}$, $T_A = -40\text{ }^\circ\text{C to }+85\text{ }^\circ\text{C}$)

Parameter	Symbol	Pin name	Conditions	Value		Unit	Remarks
				Min	Max		
Input pulse width	t_{TIWH} t_{TIWL}	TIN0, IN0, IN1, PWC0 to PWC2	—	$4 t_{CP}^*$	—	ns	

* : t_{CP} is internal operating clock cycle time. Refer to “(1) Clock Timing”.

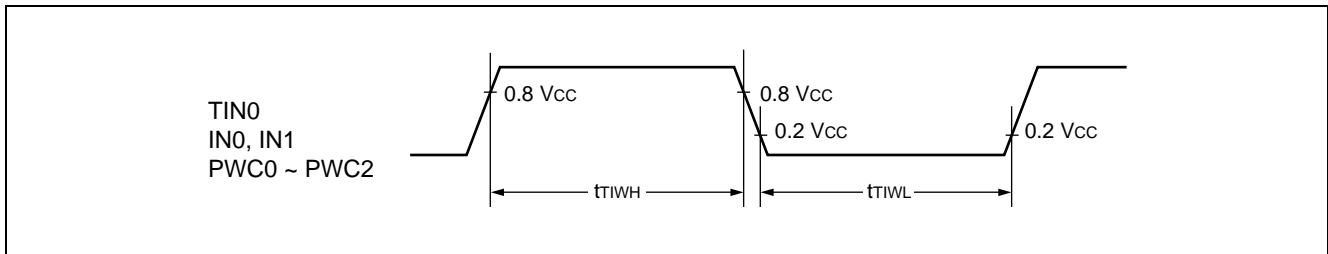

(12) Timer Output Timing

($V_{CC} = 2.7\text{ V to }3.6\text{ V}$, $V_{SS} = 0.0\text{ V}$, $T_A = -40\text{ }^\circ\text{C to }+85\text{ }^\circ\text{C}$)

Parameter	Symbol	Pin name	Conditions	Value		Unit	Remarks
				Min	Max		
CLK \uparrow →Change time PPG0 to PPG5 change time OUT0 to OUT5 change time	t_{TO}	TOT0, PPG0 to PPG5, OUT0 to OUT5	Load conditions 80 pF	30	—	ns	

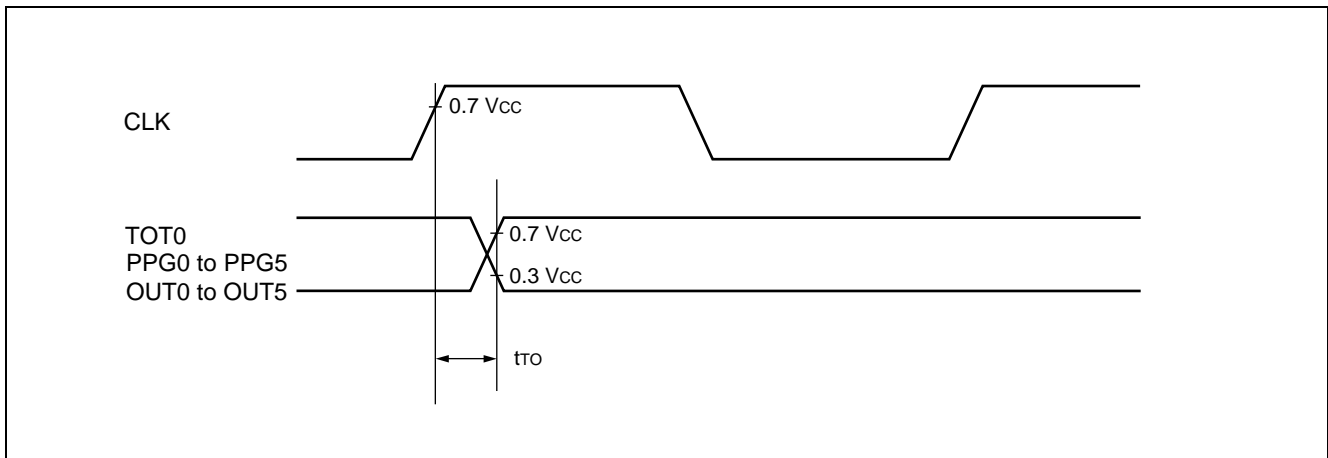

MB90480/485 Series

(13) I²C Timing

(V_{CC} = 2.7 V to 3.6 V, V_{SS} = 0.0 V, T_A = -40 °C to +85 °C)

Parameter	Symbol	Condition	Standard-mode		Unit
			Min	Max	
SCL clock frequency	f _{SCL}		0	100	kHz
Hold time (repeated) START condition SDA↓→SCL↓	t _{HDSTA}	When power supply voltage of external pull-up resistance is 5.5 V R = 1.3 kΩ, C = 50 pF*2	4.0	—	μs
“L” width of the SCL clock	t _{LOW}		4.7	—	μs
“H” width of the SCL clock	t _{HIGH}		4.0	—	μs
Set-up time (repeated) START condition SCL↑→SDA↓	t _{SUSTA}	When power supply voltage of external pull-up resistance is 3.6 V R = 1.6 kΩ, C = 50 pF*2	4.7	—	μs
Data hold time SCL↓→SDA↓↑	t _{HDDAT}		0	3.45*3	μs
Data set-up time SDA↓↑→SCL↑	t _{SUDAT}	When power supply voltage of external pull-up resistance is 5.5 V f _{CP} *1 ≤ 20 MHz, R = 1.3 kΩ, C = 50 pF*2 When power supply voltage of external pull-up resistance is 3.6 V f _{CP} *1 ≤ 20 MHz, R = 1.6 kΩ, C = 50 pF*2	250*4	—	ns
		When power supply voltage of external pull-up resistance is 5.5 V f _{CP} *1 > 20 MHz, R = 1.3 kΩ, C = 50 pF*2 When power supply voltage of external pull-up resistance is 3.6 V f _{CP} *1 > 20 MHz, R = 1.6 kΩ, C = 50 pF*2	200*4	—	ns
Set-up time for STOP condition SCL↑→SDA↑	t _{SUSTO}	When power supply voltage of external pull-up resistance is 5.5 V R = 1.3 kΩ, C = 50 pF*2	4.0	—	μs
Bus free time between a STOP and START condition	t _{BUS}	When power supply voltage of external pull-up resistance is 3.6 V R = 1.6 kΩ, C = 50 pF*2	4.7	—	μs

*1 : f_{CP} is internal operation clock frequency. Refer to “(1) Clock Timing”.

*2 : R,C : Pull-up resistor and load capacitor of the SCL and SDA lines.

*3 : The maximum t_{HDDAT} only has to be met if the device does not stretch the “L” width (t_{LOW}) of the SCL signal.

*4 : Refer to “Note of SDA and SCL set-up time”.

Note : V_{CC} = V_{CC3} = V_{CC5}

- Note of SDA and SCL set-up time

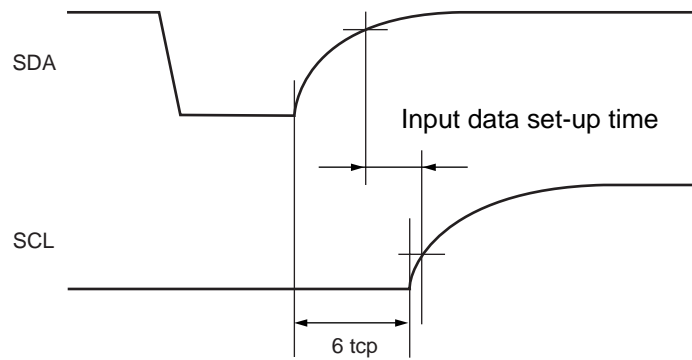

Note : The rating of the input data set-up time in the device connected to the bus cannot be satisfied depending on the load capacitance or pull-up resistor.

Be sure to adjust the pull-up resistor of SDA and SCL if the rating of the input data set-up time cannot be satisfied.

- Timing definition

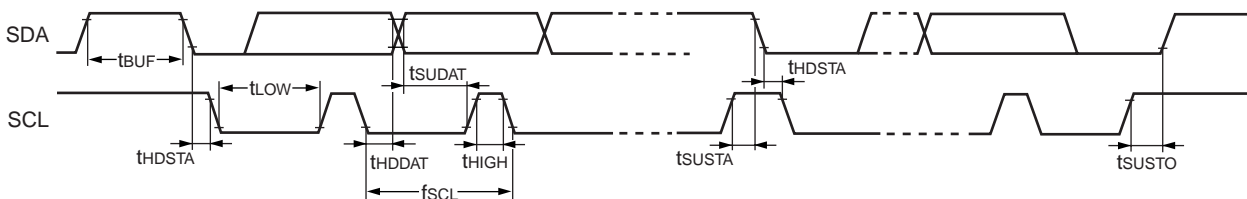

MB90480/485 Series

(14) Trigger Input Timing

($V_{CC} = 2.7\text{ V to }3.6\text{ V}$, $V_{SS} = 0.0\text{ V}$, $T_A = -40\text{ }^\circ\text{C to }+85\text{ }^\circ\text{C}$)

Parameter	Symbol	Pin name	Conditions	Value		Unit	Remarks
				Min	Max		
Input pulse width	t_{TRGH}	ADTG, IRQ0 to IRQ7	—	$5 t_{CP}^*$	—	ns	Normal operation
	t_{TRGL}			1	—	μs	Stop mode

* : t_{CP} is internal operating clock cycle time. Refer to “(1) Clock Timing”.

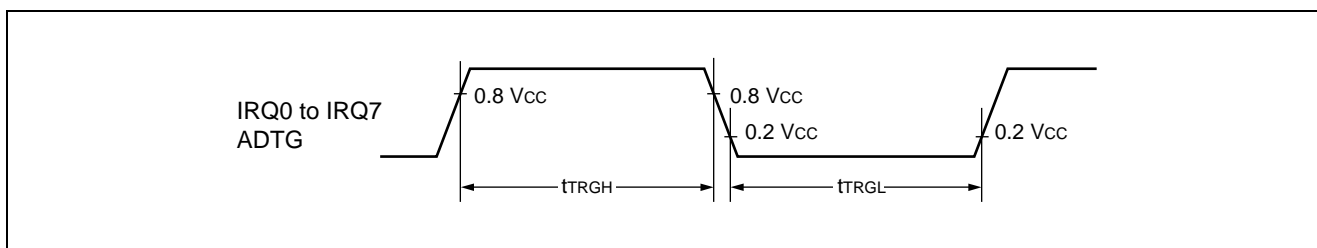

(15) Up-down Counter Timing

($V_{CC} = 2.7\text{ V to }3.6\text{ V}$, $V_{SS} = 0.0\text{ V}$, $T_A = -40\text{ }^\circ\text{C to }+85\text{ }^\circ\text{C}$)

Parameter	Symbol	Pin name	Conditions	Value		Unit	Remarks
				Min	Max		
AIN input “H” pulse width	t_{AHL}	AIN0, AIN1, BIN0, BIN1	Load conditions 80 pF	$8 t_{CP}^*$	—	ns	
AIN input “L” pulse width	t_{ALL}			$8 t_{CP}^*$	—	ns	
BIN input “H” pulse width	t_{BHL}			$8 t_{CP}^*$	—	ns	
BIN input “L” pulse width	t_{BLL}			$8 t_{CP}^*$	—	ns	
AIN \uparrow →BIN \uparrow rise time	t_{AUBU}			$4 t_{CP}^*$	—	ns	
BIN \uparrow →AIN \downarrow fall time	t_{BUAD}			$4 t_{CP}^*$	—	ns	
AIN \downarrow →BIN \uparrow rise time	t_{ADBD}			$4 t_{CP}^*$	—	ns	
BIN \downarrow →AIN \uparrow rise time	t_{BDAU}			$4 t_{CP}^*$	—	ns	
BIN \uparrow →AIN \uparrow rise time	t_{BUAU}			$4 t_{CP}^*$	—	ns	
AIN \uparrow →BIN \downarrow fall time	t_{AUBD}			$4 t_{CP}^*$	—	ns	
BIN \downarrow →AIN \uparrow rise time	t_{BDAD}			$4 t_{CP}^*$	—	ns	
AIN \downarrow →BIN \uparrow rise time	t_{ADBU}			$4 t_{CP}^*$	—	ns	
ZIN input “H” pulse width	t_{ZHL}	ZIN0, ZIN1		$4 t_{CP}^*$	—	ns	
ZIN input “L” pulse width	t_{ZLL}			$4 t_{CP}^*$	—	ns	

* : t_{CP} is internal operating clock cycle time. Refer to “(1) Clock Timing”.

MB90480/485 Series

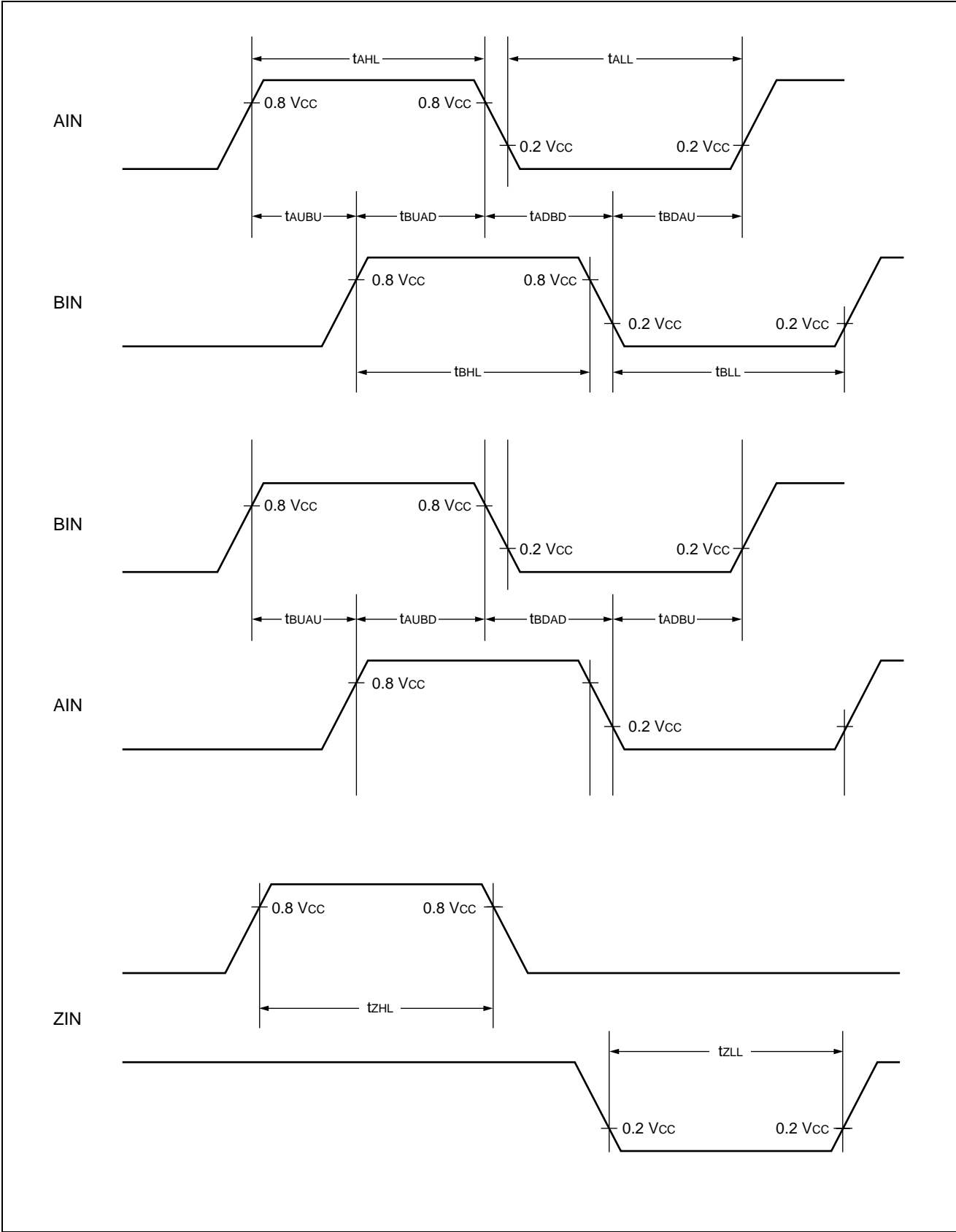

MB90480/485 Series

(16) Chip Select Output Timing

($V_{CC} = 2.7\text{ V to }3.6\text{ V}$, $V_{SS} = 0.0\text{ V}$, $T_A = -40\text{ }^{\circ}\text{C to }+85\text{ }^{\circ}\text{C}$)

Parameter	Symbol	Pin name	Conditions	Value		Unit	Remarks
				Min	Max		
Chip select output valid time $\rightarrow \overline{RD}\downarrow$	t_{SVRL}	CS0 to CS3, \overline{RD}	—	$t_{CP}^* / 2 - 7$	—	ns	
Chip select output valid time $\rightarrow \overline{WR}\downarrow$	t_{SVWL}	CS0 to CS3, \overline{WRH} , \overline{WRL}	—	$t_{CP}^* / 2 - 7$	—	ns	
$\overline{RD}\uparrow \rightarrow$ chip select output valid time	t_{RHVS}	\overline{RD} , CS0 to CS3	—	$t_{CP}^* / 2 - 17$	—	ns	
$\overline{WR}\uparrow \rightarrow$ chip select output valid time	t_{WHVS}	\overline{WRH} , \overline{WRL} , CS0 to CS3	—	$t_{CP}^* / 2 - 17$	—	ns	

* : t_{CP} is internal operating clock cycle time. Refer to “(1) Clock Timing”.

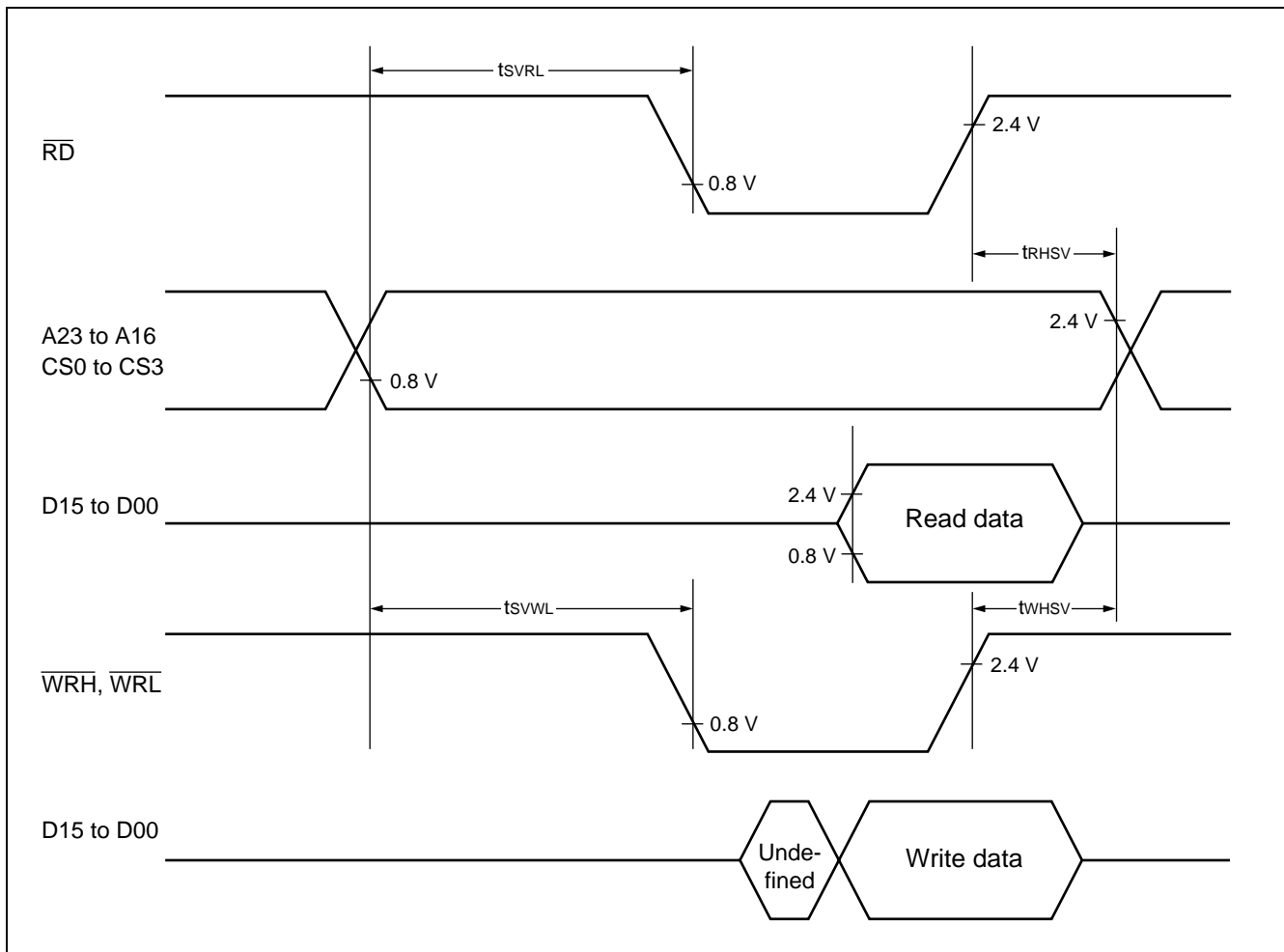

Note : Due to the configuration of the internal bus, changes in the chip select output signal are clock synchronous and therefore may causes bus conflict conditions. AC cannot be warranted between the ALE output signal and the chip select output signal.

5. A/D Converter Electrical Characteristics

($V_{CC} = AV_{CC} = 2.7\text{ V}$ to 3.6 V , $V_{SS} = AV_{SS} = 0.0\text{ V}$, $2.7\text{ V} \leq AVRH$, $T_A = -40\text{ }^\circ\text{C}$ to $+85\text{ }^\circ\text{C}$)

Parameter	Symbol	Pin name	Value			Unit	Remarks
			Min	Typ	Max		
Resolution	—	—	—	—	10	bit	
Total error	—	—	—	—	± 3.0	LSB	
Non-linear error	—	—	—	—	± 2.5	LSB	
Differential linearity error	—	—	—	—	± 1.9	LSB	
Zero transition voltage	V_{OT}	AN0 to AN7	$AV_{SS} - 1.5\text{ LSB}$	$AV_{SS} + 0.5\text{ LSB}$	$AV_{SS} + 2.5\text{ LSB}$	mV	
Full scale transition voltage	V_{FST}	AN0 to AN7	$AVRH - 3.5\text{ LSB}$	$AVRH - 1.5\text{ LSB}$	$AVRH + 0.5\text{ LSB}$	mV	
Conversion time	—	—	3.68 *1	—	—	μs	
Analog port input current	I_{AIN}	AN0 to AN7	—	0.1	10	μA	
Analog input voltage	V_{AIN}	AN0 to AN7	AV_{SS}	—	$AVRH$	V	
Reference voltage	—	$AVRH$	$AV_{SS} + 2.2$	—	AV_{CC}	V	
Power supply current	I_A	AV_{CC}	—	1.4	3.5	mA	
	I_{AH}	AV_{CC}	—	—	5 *2	μA	
Reference voltage supply current	I_R	$AVRH$	—	94	150	μA	
	I_{RH}	$AVRH$	—	—	5 *2	μA	
Offset between channels	—	AN0 to AN7	—	—	4	LSB	

*1 : At machine clock frequency of 25 MHz.

*2 : CPU stop mode current when A/D converter is not operating (at $V_{CC} = AV_{CC} = AVRH = 3.0\text{ V}$).

(Continued)

MB90480/485 Series

(Continued)

- **About the external impedance of the analog input and its sampling time**

- A/D converter with sample and hold circuit. If the external impedance is too high to keep sufficient sampling time, the analog voltage charged to the internal sample and hold capacitor is insufficient, adversely affecting A/D conversion precision.

- Analog input circuit model

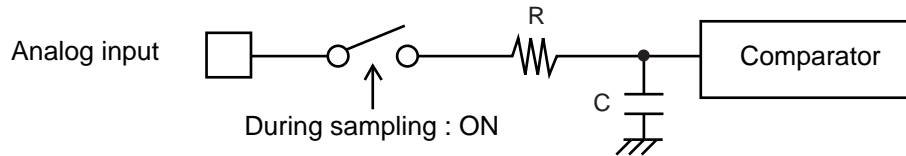

	R	C
MB90487B	2.5 kΩ (Max)	31.0 pF (Max)
MB90F481/F482	1.9 kΩ (Max)	25.0 pF (Max)
MB90F488B/F489B	1.9 kΩ (Max)	25.0 pF (Max)

Note: The values are reference values.

- To satisfy the A/D conversion precision standard, consider the relationship between the external impedance and minimum sampling time and either adjust the resistor value and operating frequency or decrease the external impedance so that the sampling time is longer than the minimum value.

- The relationship between external impedance and minimum sampling time

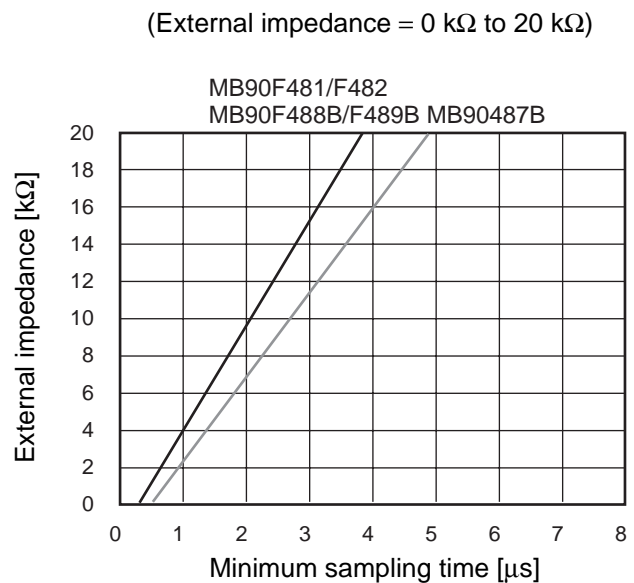
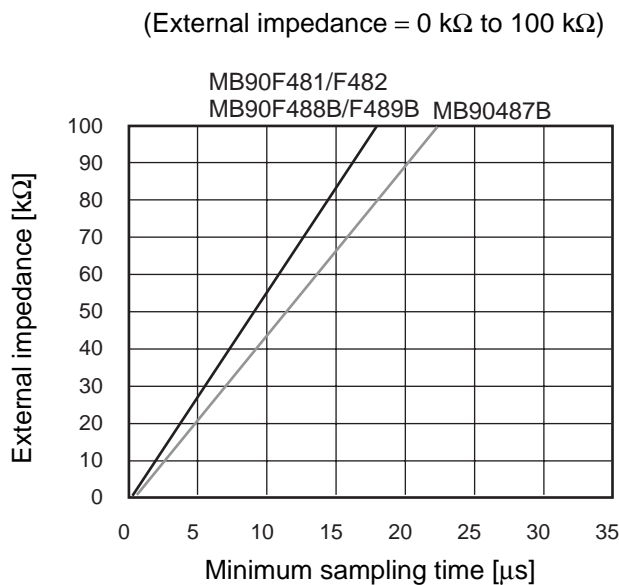

- If the sampling time cannot be sufficient, connect a capacitor of about 0.1 μF to the analog input pin.

- **About errors**

As $|AV_{RH} - AV_{SS}|$ becomes smaller, values of relative errors grow larger.

Note : Concerning sampling time, and compare time When $3.6 V \geq AV_{CC} \geq 2.7 V$, then

Sampling time : 1.92 μs, compare time : 1.1 μs

Settings should ensure that actual values do not go below these values due to operating frequency changes.

•Flash Memory Program/Erase Characteristics

Parameter	Conditions	Value			Unit	Remarks
		Min	Typ	Max		
Sector erase time	$T_A = +25\text{ }^\circ\text{C}$, $V_{CC} = 3.0\text{ V}$	—	1	15	s	Excludes 00H programming prior erasure
Chip erase time		—	7	—	s	Excludes 00H programming prior erasure
Word (16-bit) programming time		—	16	3,600	μs	Excludes system-level overhead
Program/Erase cycle	—	10,000	—	—	cycle	
Flash Memory Data hold time	Average $T_A = +85\text{ }^\circ\text{C}$	10	—	—	year	*

* : The value comes from the technology qualification (using Arrhenius equation to translate high temperature measurements into normalized value at +85 °C) .

•Use of the X0/X1, X0A/X1A pins

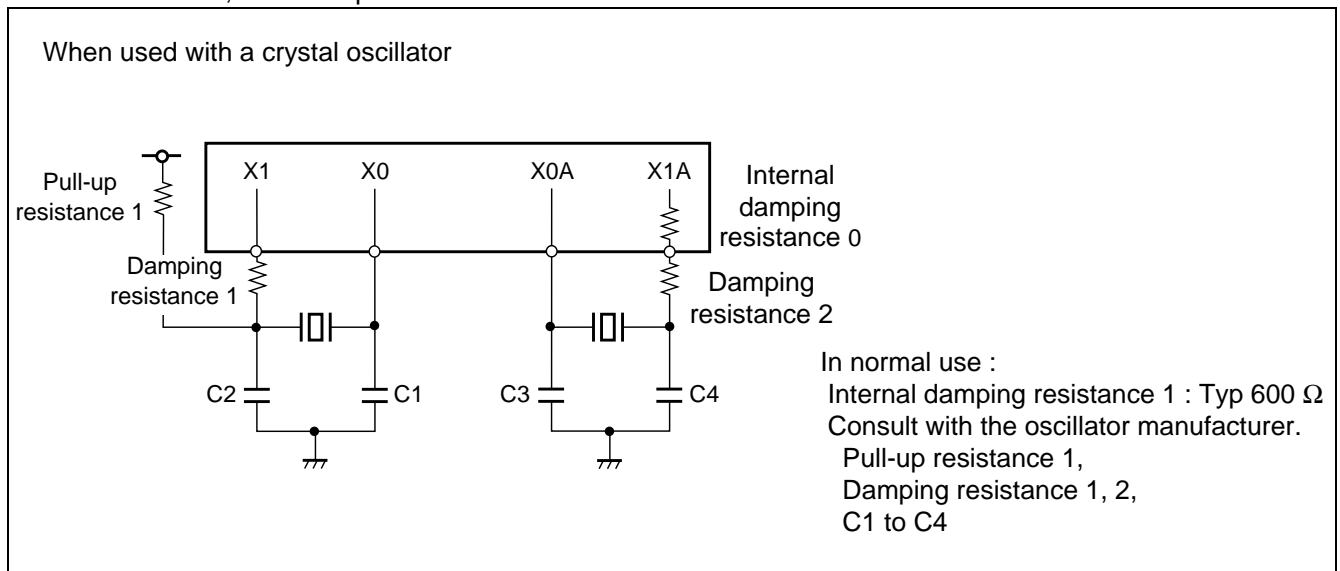

•Sample use with external clock input

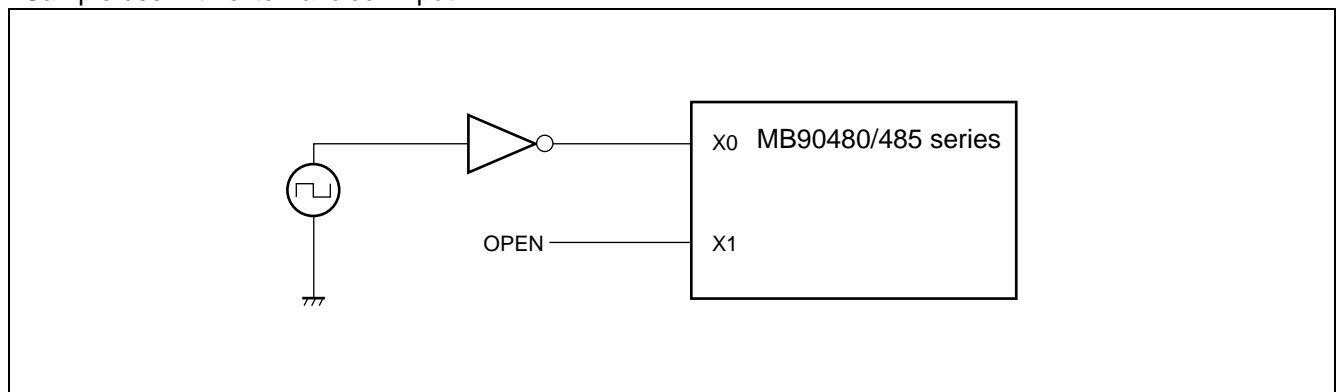

MB90480/485 Series

EXAMPLE CHARACTERISTICS

• MB90F482

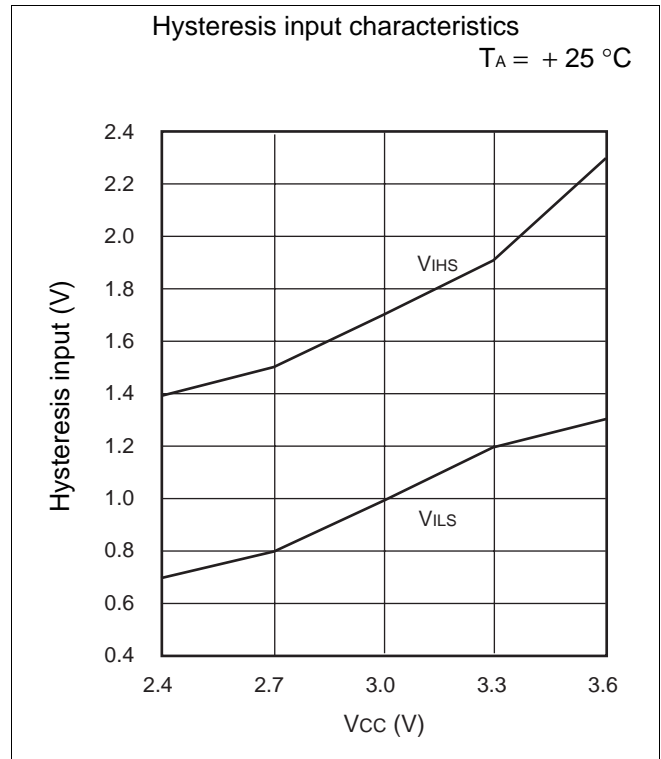
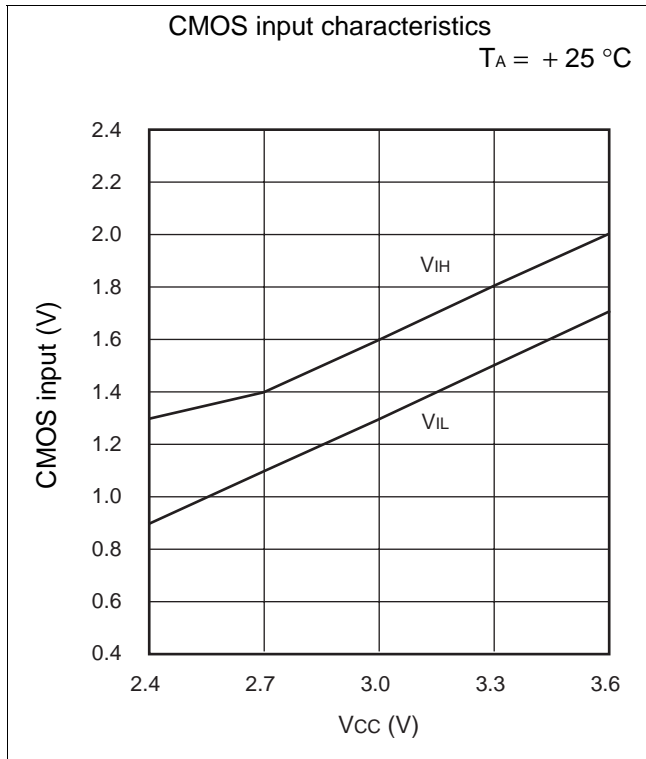
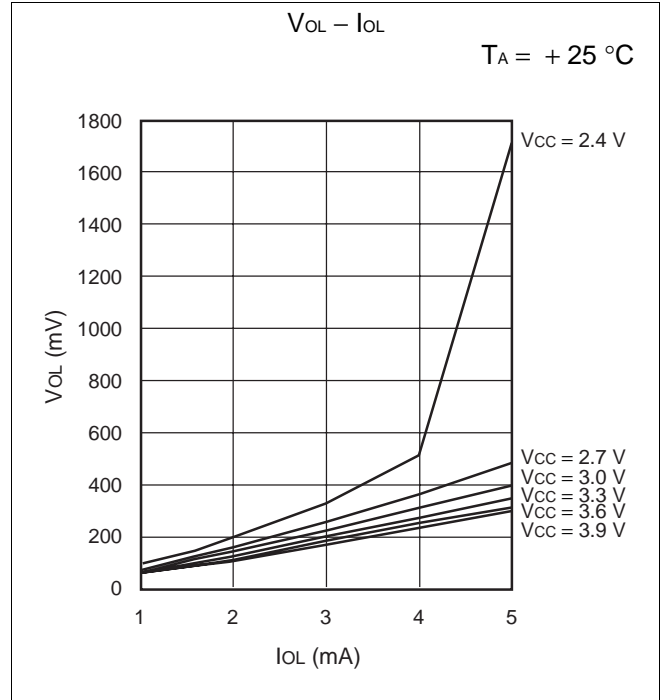
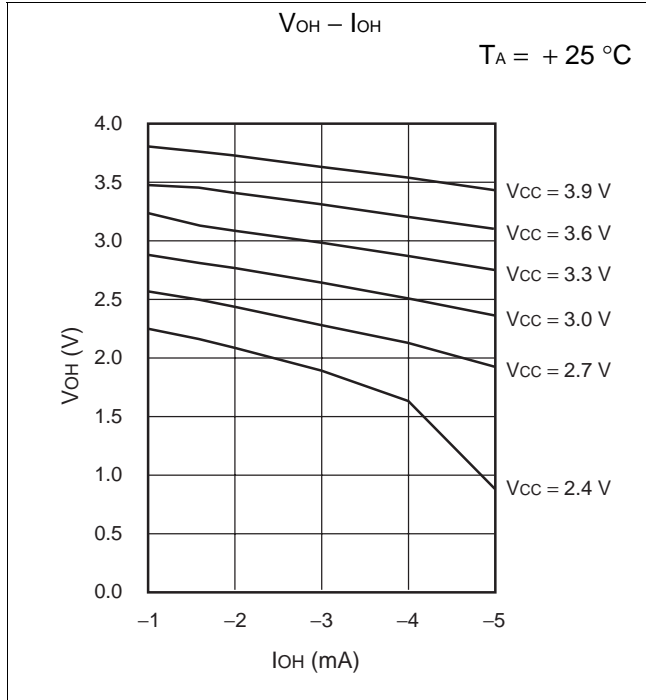

(Continued)

MB90480/485 Series

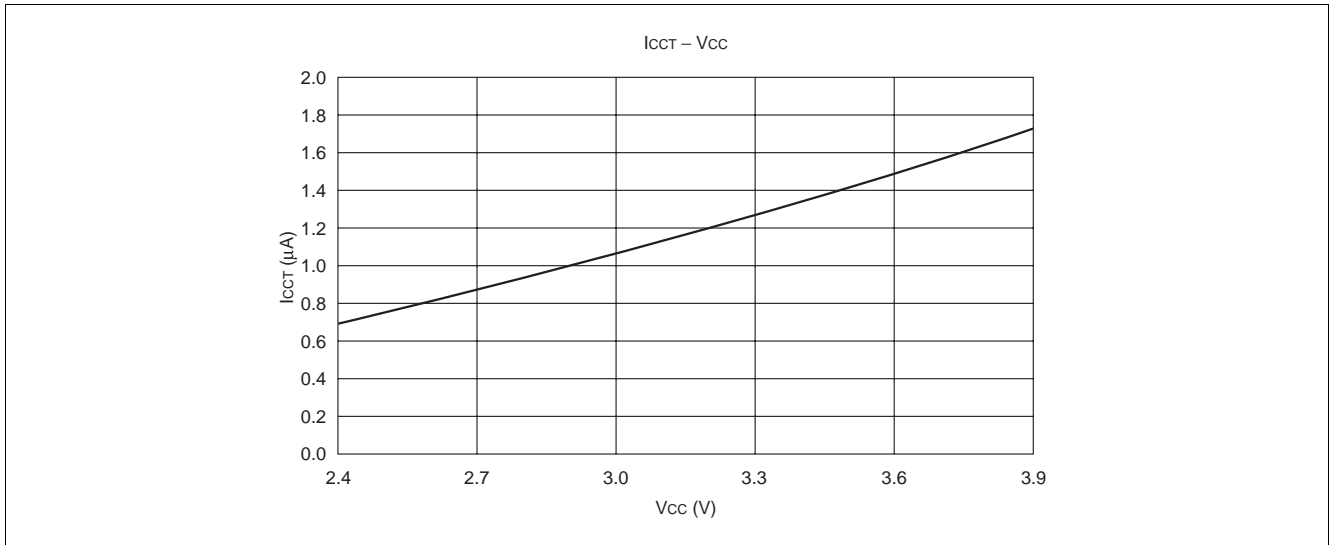
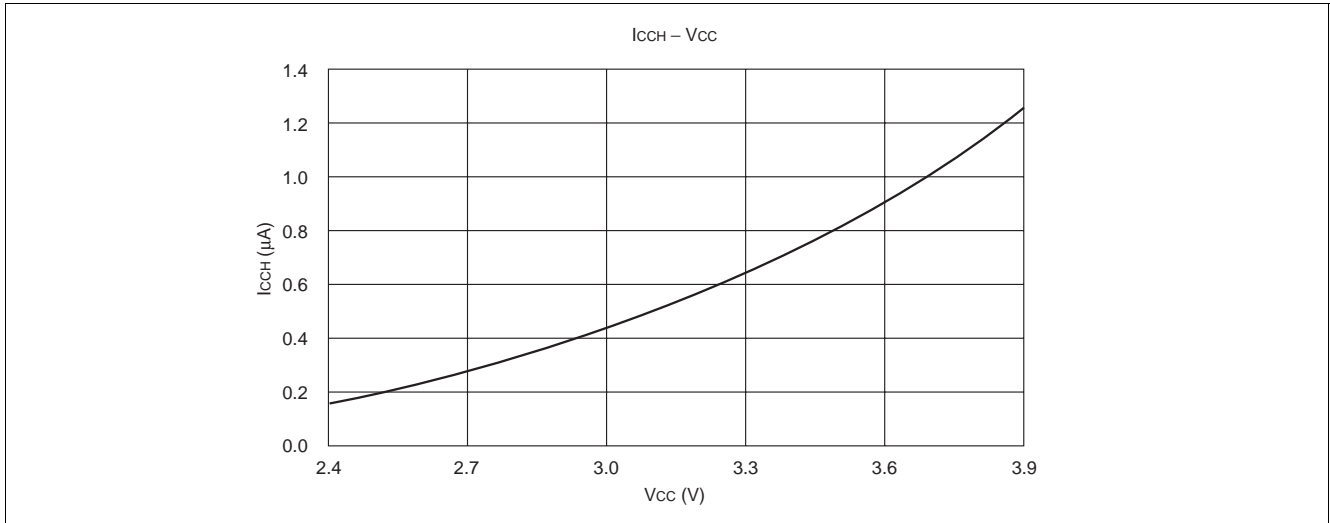
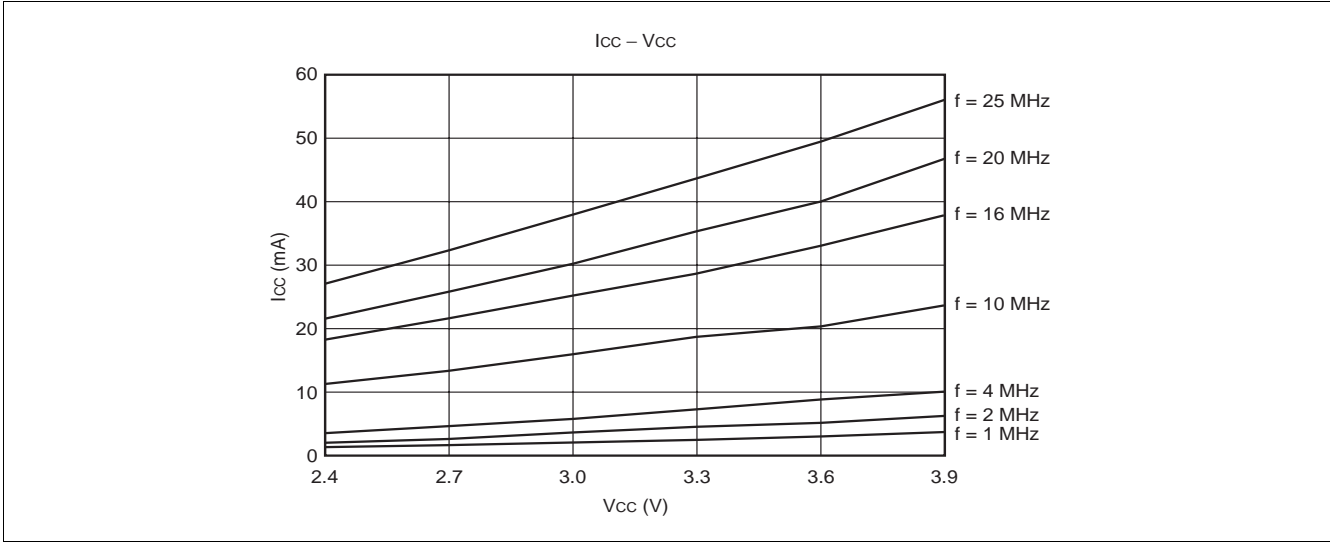

(Continued)

MB90480/485 Series

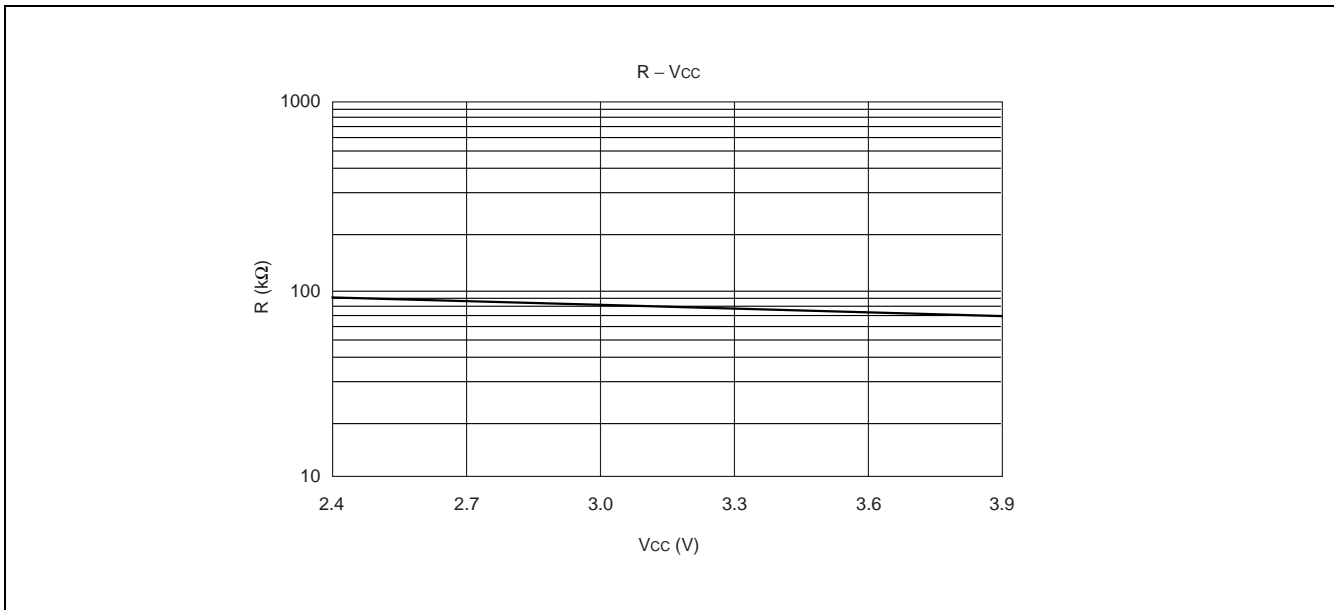
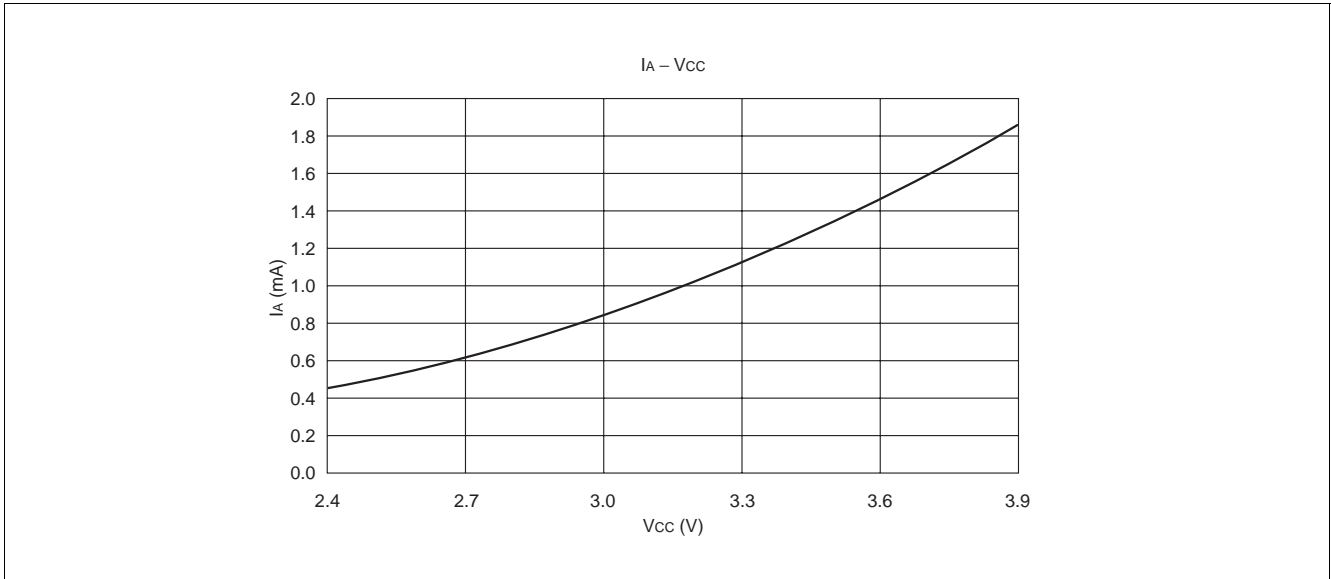

(Continued)

(Continued)

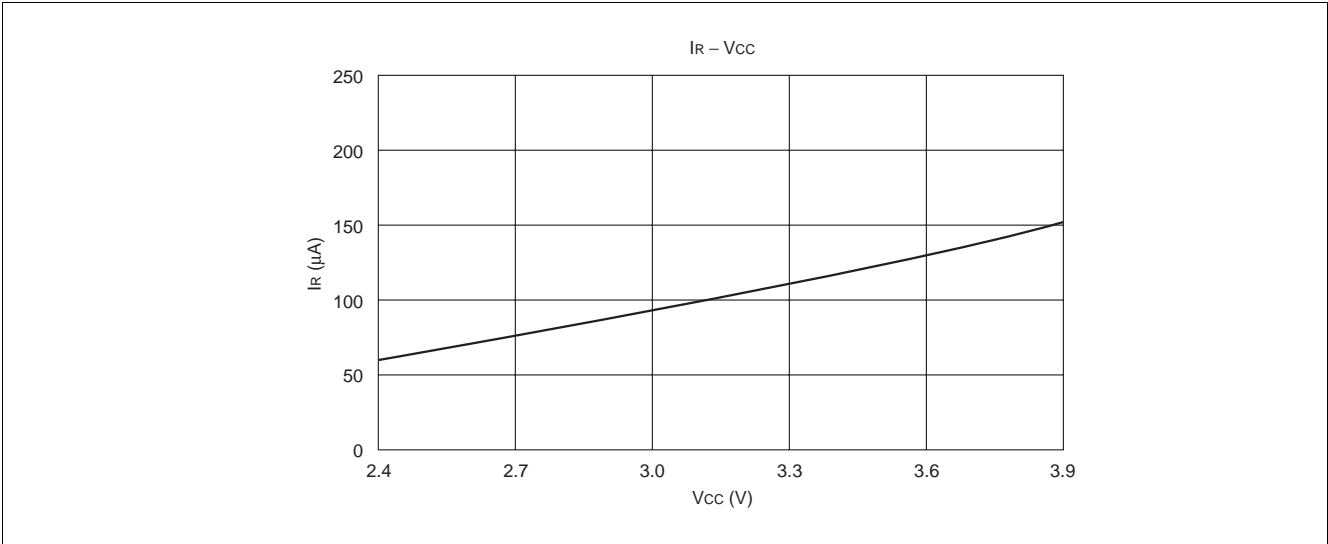
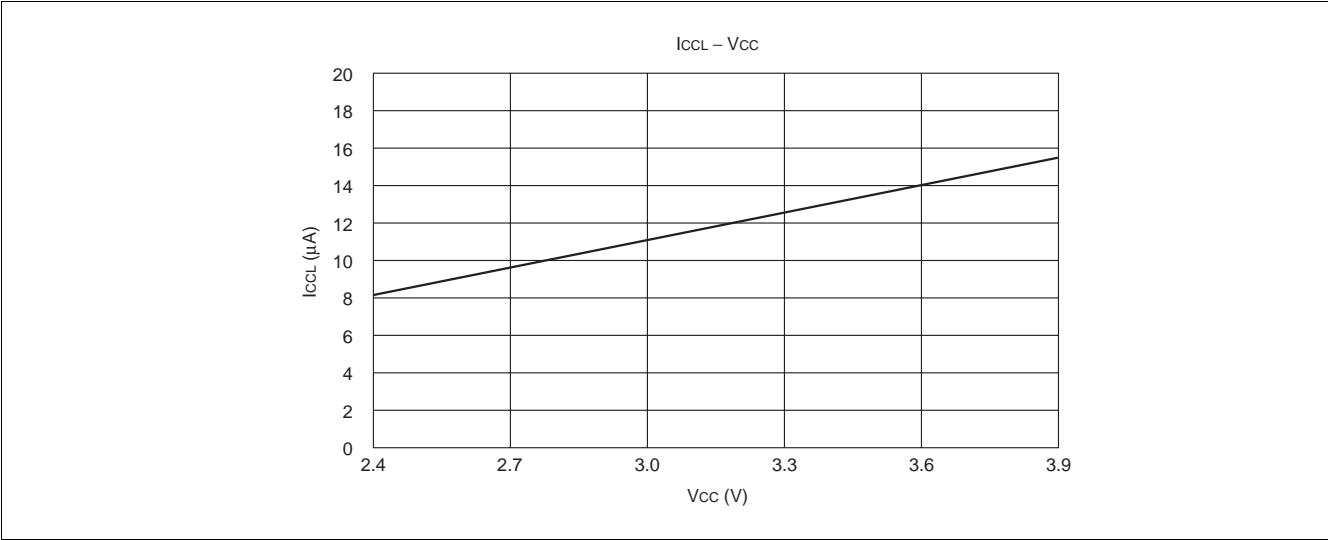
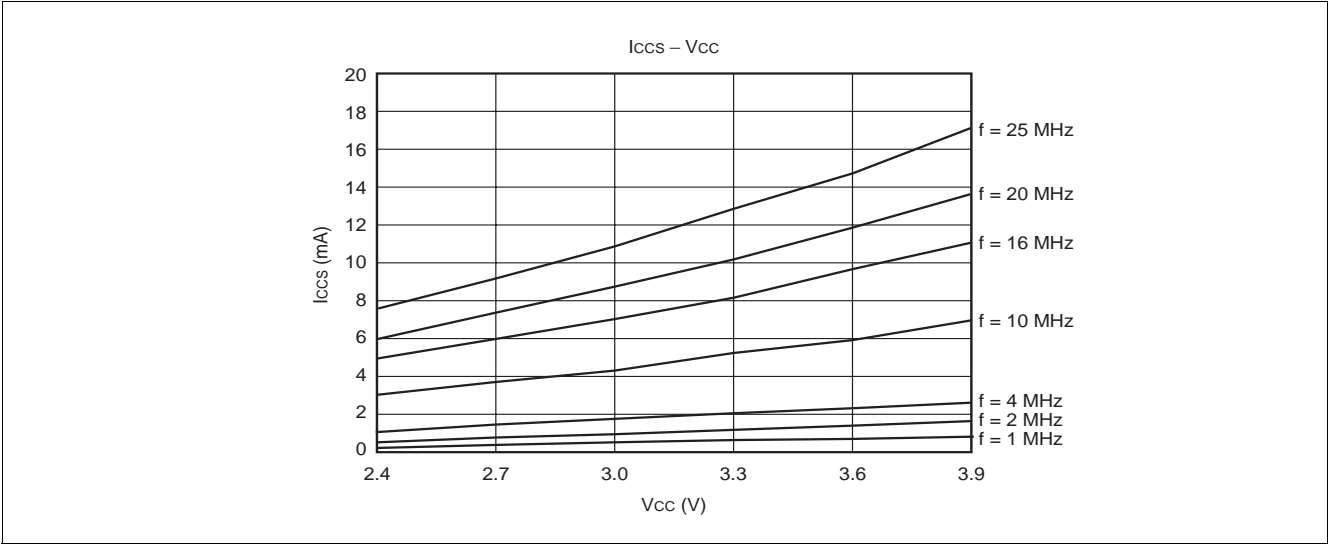

MB90480/485 Series

■ ORDERING INFORMATION

Model	Package	Remarks
MB90F481PF MB90F482PF MB90487BPF MB90488BPF MB90F488BPF MB90483BPF MB90F489BPF	100-pin plastic QFP (FPT-100P-M06)	
MB90F481PFV MB90F482PFV MB90487BPFV MB90488BPFV MB90F488BPFV MB90483BPFV MB90F489BPFV	100-pin plastic LQFP (FPT-100P-M05)	

MB90480/485 Series

■ PACKAGE DIMENSIONS

100-pin plastic QFP
(FPT-100P-M06)

Note 1) * : These dimensions do not include resin protrusion.
 Note 2) Pins width and pins thickness include plating thickness.
 Note 3) Pins width do not include tie bar cutting remainder.

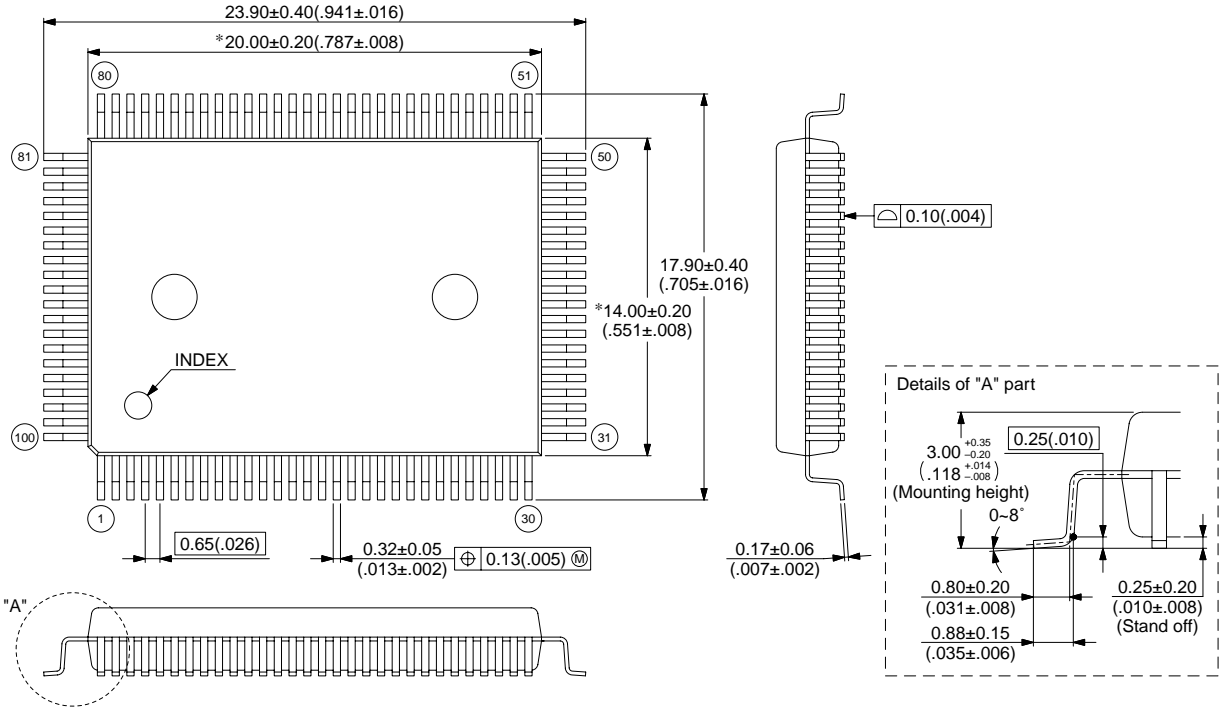

© 2002 FUJITSU LIMITED F100008S-c-5-5

Dimensions in mm (inches)
 Note : The values in parentheses are reference values.

(Continued)

MB90480/485 Series

(Continued)

100-pin plastic LQFP
(FPT-100P-M05)

Note 1) * : These dimensions do not include resin protrusion.
 Note 2) Pins width and pins thickness include plating thickness.
 Note 3) Pins width do not include tie bar cutting remainder.

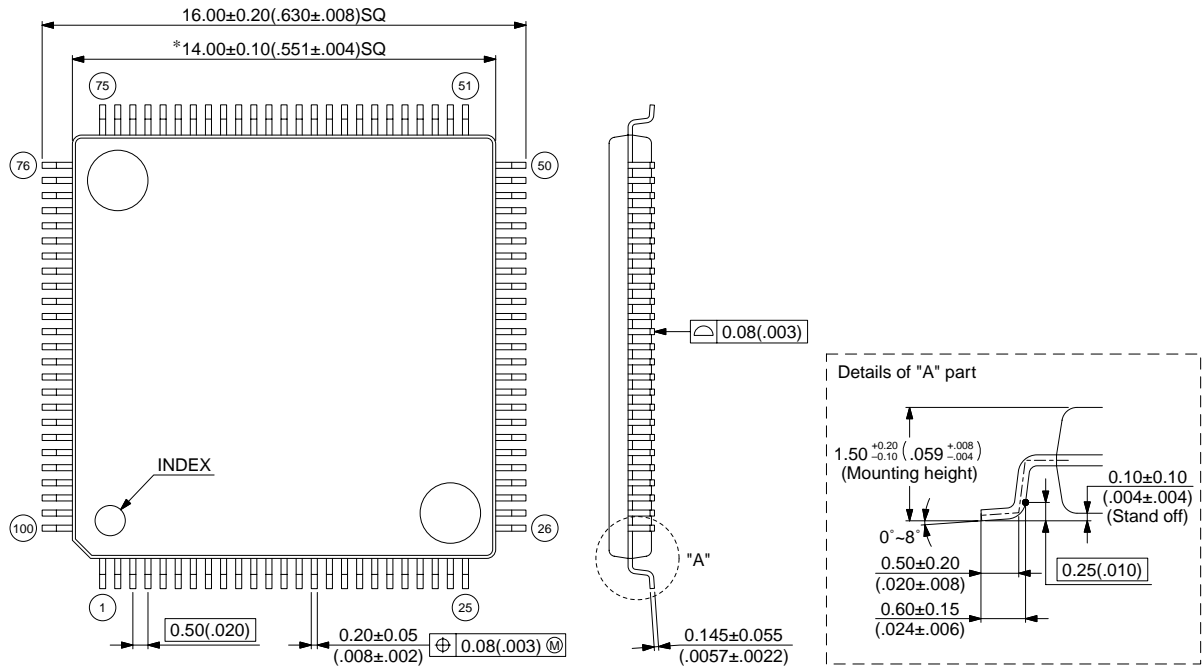

© 2003 FUJITSU LIMITED F100007S-c-4-6

Dimensions in mm (inches)
 Note : The values in parentheses are reference values.

FUJITSU LIMITED

All Rights Reserved.

The contents of this document are subject to change without notice. Customers are advised to consult with FUJITSU sales representatives before ordering.

The information, such as descriptions of function and application circuit examples, in this document are presented solely for the purpose of reference to show examples of operations and uses of Fujitsu semiconductor device; Fujitsu does not warrant proper operation of the device with respect to use based on such information. When you develop equipment incorporating the device based on such information, you must assume any responsibility arising out of such use of the information. Fujitsu assumes no liability for any damages whatsoever arising out of the use of the information.

Any information in this document, including descriptions of function and schematic diagrams, shall not be construed as license of the use or exercise of any intellectual property right, such as patent right or copyright, or any other right of Fujitsu or any third party or does Fujitsu warrant non-infringement of any third-party's intellectual property right or other right by using such information. Fujitsu assumes no liability for any infringement of the intellectual property rights or other rights of third parties which would result from the use of information contained herein.

The products described in this document are designed, developed and manufactured as contemplated for general use, including without limitation, ordinary industrial use, general office use, personal use, and household use, but are not designed, developed and manufactured as contemplated (1) for use accompanying fatal risks or dangers that, unless extremely high safety is secured, could have a serious effect to the public, and could lead directly to death, personal injury, severe physical damage or other loss (i.e., nuclear reaction control in nuclear facility, aircraft flight control, air traffic control, mass transport control, medical life support system, missile launch control in weapon system), or (2) for use requiring extremely high reliability (i.e., submersible repeater and artificial satellite).

Please note that Fujitsu will not be liable against you and/or any third party for any claims or damages arising in connection with above-mentioned uses of the products.

Any semiconductor devices have an inherent chance of failure. You must protect against injury, damage or loss from such failures by incorporating safety design measures into your facility and equipment such as redundancy, fire protection, and prevention of over-current levels and other abnormal operating conditions.

If any products described in this document represent goods or technologies subject to certain restrictions on export under the Foreign Exchange and Foreign Trade Law of Japan, the prior authorization by Japanese government will be required for export of those products from Japan.

F0509

© 2005 FUJITSU LIMITED Printed in Japan