

Am29LV64IMH/L

Data Sheet



RETIRED
PRODUCT

This product has been retired and is not available for designs. For new and current designs, S29GL064A supersedes Am29LV641M H/L and is the factory-recommended migration path. Please refer to the S29GL064A datasheet for specifications and ordering information. Availability of this document is retained for reference and historical purposes only.

April 2005

The following document specifies Spansion memory products that are now offered by both Advanced Micro Devices and Fujitsu. Although the document is marked with the name of the company that originally developed the specification, these products will be offered to customers of both AMD and Fujitsu.

Continuity of Specifications

There is no change to this datasheet as a result of offering the device as a Spansion product. Any changes that have been made are the result of normal datasheet improvement and are noted in the document revision summary, where supported. Future routine revisions will occur when appropriate, and changes will be noted in a revision summary.

For More Information

Please contact your local AMD or Fujitsu sales office for additional information about Spansion memory solutions.



THIS PAGE LEFT INTENTIONALLY BLANK.



Am29LV641MH/L

64 Megabit (4 M x 16-Bit) MirrorBit™ 3.0 Volt-only Uniform Sector Flash Memory with Versatile/O™ Control

This product has been retired and is not available for designs. For new and current designs, S29GL064A supersedes Am29LV641M H/L and is the factory-recommended migration path. Please refer to the S29GL064A datasheet for specifications and ordering information. Availability of this document is retained for reference and historical purposes only.

ARCHITECTURAL ADVANTAGES

- **Single power supply operation**
 - 3 V for read, erase, and program operations
- **Versatile/O™ control**
 - Device generates data output voltages and tolerates data input voltages on CE# and the DQ inputs/outputs as determined by the voltage on the V_{IO} pin; operates from 1.65 to 3.6 V
- **Manufactured on 0.23 μm MirrorBit process technology**
- **SecSi™ (Secured Silicon) Sector region**
 - 128-word sector for permanent, secure identification through an 8-word random Electronic Serial Number, accessible through a command sequence
 - May be programmed and locked at the factory or by the customer
- **Flexible sector architecture**
 - One hundred twenty-eight 32 Kword sectors
- **Compatibility with JEDEC standards**
 - Provides pinout and software compatibility for single-power supply flash, and superior inadvertent write protection
- **Minimum 100,000 erase cycle guarantee per sector**
- **20-year data retention at 125°C**

PERFORMANCE CHARACTERISTICS

- **High performance**
 - 90 ns access time
 - 25 ns page read times
 - 0.5 s typical sector erase time
 - 22 μs typical effective write buffer word programming time: 16-word write buffer reduces overall programming time for multiple-word updates
 - 4-word page read buffer
 - 16-word write buffer

- **Low power consumption (typical values at 3.0 V, 5 MHz)**
 - 30 mA typical active read current
 - 50 mA typical erase/program current
 - 1 μA typical standby mode current

- **Package options**
 - 48-pin TSOP

SOFTWARE & HARDWARE FEATURES

- **Software features**
 - Program Suspend & Resume: read other sectors before programming operation is completed
 - Erase Suspend & Resume: read/program other sectors before an erase operation is completed
 - Data# polling & toggle bits provide status
 - Unlock Bypass Program command reduces overall multiple-word programming time
 - CFI (Common Flash Interface) compliant: allows host system to identify and accommodate multiple flash devices
- **Hardware features**
 - Sector Group Protection: hardware-level method of preventing write operations within a sector group
 - Temporary Sector Unprotect: V_{ID}-level method of changing code in locked sectors
 - ACC (high voltage) input accelerates programming time for higher throughput during system production
 - Write Protect input (WP#) protects first or last sector regardless of sector protection settings
 - Hardware reset input (RESET#) resets device

GENERAL DESCRIPTION

The Am29LV641MH/L is a 64 Mbit, 3.0 volt single power supply flash memory devices organized as 4,194,304 words. The devices have a 16-bit wide data bus, and can be programmed either in the host system or in standard EPROM programmers.

An access time of 90, 100, 110, or 120 ns is available. Note that each access time has a specific operating voltage range (V_{CC}) and an I/O voltage range (V_{IO}), as specified in the [Product Selector Guide](#) and the [Ordering Information](#) sections. The device is offered in a 48-pin TSOP package. Each device has separate chip enable (CE#), write enable (WE#) and output enable (OE#) controls.

Each device requires only a **single 3.0 volt power supply** for both read and write functions. In addition to a V_{CC} input, a high-voltage **accelerated program (ACC)** input provides shorter programming times through increased current. This feature is intended to facilitate factory throughput during system production, but may also be used in the field if desired.

The device is entirely command set compatible with the **JEDEC single-power-supply Flash standard**. Commands are written to the device using standard microprocessor write timing. Write cycles also internally latch addresses and data needed for the programming and erase operations.

The **sector erase architecture** allows memory sectors to be erased and reprogrammed without affecting the data contents of other sectors. The device is fully erased when shipped from the factory.

Device programming and erasure are initiated through command sequences. Once a program or erase operation has begun, the host system need only poll the DQ7 (Data# Polling) or DQ6 (toggle) **status bits** to determine whether the operation is complete. To facilitate programming, an **Unlock Bypass** mode reduces command sequence overhead by requiring only two write cycles to program data instead of four.

The **VersatileI/O™** (V_{IO}) control allows the host system to set the voltage levels that the device generates and tolerates on the CE# control input and DQ I/Os to the same voltage level that is asserted on the V_{IO} pin.

Refer to the [Ordering Information](#) section for valid V_{IO} options.

Hardware data protection measures include a low V_{CC} detector that automatically inhibits write operations during power transitions. The hardware sector protection feature disables both program and erase operations in any combination of sectors of memory. This can be achieved in-system or via programming equipment.

The **Erase Suspend/Erase Resume** feature allows the host system to pause an erase operation in a given sector to read or program any other sector and then complete the erase operation. The **Program Suspend/Program Resume** feature enables the host system to pause a program operation in a given sector to read any other sector and then complete the program operation.

The **hardware RESET# pin** terminates any operation in progress and resets the device, after which it is then ready for a new operation. The RESET# pin may be tied to the system reset circuitry. A system reset would thus also reset the device, enabling the host system to read boot-up firmware from the Flash memory device.

The device reduces power consumption in the **standby mode** when it detects specific voltage levels on CE# and RESET#, or when addresses have been stable for a specified period of time.

The **SecSi™ (Secured Silicon) Sector** provides a 128-word area for code or data that can be permanently protected. Once this sector is protected, no further changes within the sector can occur.

The **Write Protect (WP#)** feature protects the first or last sector by asserting a logic low on the WP# pin. The protected sector will still be protected even during accelerated programming.

AMD MirrorBit flash technology combines years of Flash memory manufacturing experience to produce the highest levels of quality, reliability and cost effectiveness. The device electrically erases all bits within a sector simultaneously via hot-hole assisted erase. The data is programmed using hot electron injection.

MIRRORBIT 64 MBIT DEVICE FAMILY

| Device | Bus | Sector Architecture | Packages | V _{IO} | RY/BY# | WP#, ACC | WP# Protection |
|-----------|--------|------------------------------------|---|-----------------|--------|------------------------------|-------------------------------|
| LV065MU | x8 | Uniform (64K-byte) | 48-pin TSOP (std. & rev. pinout), 63-ball FBGA | Yes | Yes | ACC only | No WP# |
| LV640MT/B | x8/x16 | Boot (8x8K-byte @ top & bottom) | 48-pin TSOP, 63-ball Fine-pitch BGA, 64-ball Fortified BGA | No | Yes | WP#/ACC pin | 2 x 8 Kbyte top or bottom |
| LV640MH/L | x8/x16 | Uniform (64K-byte) | 56-pin TSOP (std. & rev. pinout), 64 Fortified BGA | Yes | Yes | WP#/ACC pin | 1 x 64 Kbyte high or low |
| LV641MH/L | x16 | Uniform (32K-word) | 48-pin TSOP (std. & rev. pinout) | Yes | No | Separate WP# and ACC pins | 1 x 32 Kword top or bottom |
| LV640MU | x16 | Uniform (32K-word) | 63-ball Fine-pitch BGA, 64 Ball Fortified BGA | Yes | Yes | ACC only | No WP# |

RELATED DOCUMENTS

To download related documents, click on the following links or go to www.amd.com→Flash Memory→Product Information→MirrorBit→Flash Information→Technical Documentation.

[MirrorBit™ Flash Memory Write Buffer Programming and Page Buffer Read](#)

[Implementing a Common Layout for AMD MirrorBit and Intel StrataFlash Memory Devices](#)

[AMD MirrorBit™ White Paper](#)

[Migrating from Single-byte to Three-byte Device IDs](#)

TABLE OF CONTENTS

| | | | |
|---|-----------|---|-----------|
| Continuity of Specifications | i | Sector Erase Command Sequence | 28 |
| For More Information | i | Erase Suspend/Erase Resume Commands | 29 |
| Product Selector Guide | 5 | Figure 7. Erase Operation..... | 30 |
| Block Diagram | 5 | Command Definitions | 31 |
| Connection Diagrams | 6 | Table 10. Command Definitions..... | 31 |
| Pin Description | 7 | Write Operation Status | 32 |
| Logic Symbol | 7 | DQ7: Data# Polling | 32 |
| Ordering Information | 8 | Figure 8. Data# Polling Algorithm | 32 |
| Device Bus Operations | 9 | DQ6: Toggle Bit I | 33 |
| Table 1. Device Bus Operations | 9 | Figure 9. Toggle Bit Algorithm..... | 33 |
| VersatileIO™ (V _{IO}) Control | 9 | DQ2: Toggle Bit II | 34 |
| Requirements for Reading Array Data | 9 | Reading Toggle Bits DQ6/DQ2 | 34 |
| Page Mode Read | 10 | DQ5: Exceeded Timing Limits | 34 |
| Writing Commands/Command Sequences | 10 | DQ3: Sector Erase Timer | 34 |
| Write Buffer | 10 | DQ1: Write-to-Buffer Abort | 35 |
| Accelerated Program Operation | 10 | Table 11. Write Operation Status | 35 |
| Autoselect Functions | 10 | Absolute Maximum Ratings | 36 |
| Standby Mode | 10 | Figure 10. Maximum Negative Overshoot Waveform | 36 |
| Automatic Sleep Mode | 10 | Figure 11. Maximum Positive Overshoot Waveform..... | 36 |
| RESET#: Hardware Reset Pin | 11 | Operating Ranges | 36 |
| Output Disable Mode | 11 | DC Characteristics | 37 |
| Table 2. Sector Address Table | 12 | Test Conditions | 38 |
| Autoselect Mode | 14 | Figure 12. Test Setup..... | 38 |
| Table 3. Autoselect Codes, (High Voltage Method) | 14 | Table 12. Test Specifications | 38 |
| Sector Group Protection and Unprotection | 15 | Key to Switching Waveforms | 38 |
| Table 4. Sector Group Protection/Unprotection Address Table | 15 | Figure 13. Input Waveforms and | |
| Write Protect (WP#) | 16 | Measurement Levels..... | 38 |
| Temporary Sector Group Unprotect | 16 | AC Characteristics | 39 |
| Figure 1. Temporary Sector Group Unprotect Operation..... | 16 | Read-Only Operations | 39 |
| Figure 2. In-System Sector Group Protect/Unprotect Algorithms ... | 17 | Figure 14. Read Operation Timings..... | 39 |
| SecSi (Secured Silicon) Sector Flash Memory Region | 18 | Figure 15. Page Read Timings | 40 |
| Table 5. SecSi Sector Contents | 18 | Hardware Reset (RESET#) | 41 |
| Figure 3. SecSi Sector Protect Verify..... | 19 | Figure 16. Read Operation Timings..... | 41 |
| Hardware Data Protection | 19 | Figure 17. Reset Timings..... | 42 |
| Low VCC Write Inhibit | 19 | Erase and Program Operations | 43 |
| Write Pulse “Glitch” Protection | 19 | Figure 18. Program Operation Timings..... | 44 |
| Logical Inhibit | 19 | Figure 19. Accelerated Program Timing Diagram..... | 44 |
| Power-Up Write Inhibit | 19 | Figure 20. Chip/Sector Erase Operation Timings | 45 |
| Common Flash Memory Interface (CFI) | 19 | Figure 21. Data# Polling Timings | |
| Table 6. CFI Query Identification String | 20 | (During Embedded Algorithms)..... | 46 |
| Table 7. System Interface String..... | 20 | Figure 22. Toggle Bit Timings | |
| Table 8. Device Geometry Definition..... | 21 | (During Embedded Algorithms)..... | 47 |
| Table 9. Primary Vendor-Specific Extended Query..... | 22 | Figure 23. DQ2 vs. DQ6..... | 47 |
| Command Definitions | 22 | Temporary Sector Unprotect | 48 |
| Reading Array Data | 22 | Figure 24. Temporary Sector Group Unprotect Timing Diagram ... | 48 |
| Reset Command | 23 | Figure 25. Sector Group Protect and Unprotect Timing Diagram .. | 49 |
| Autoselect Command Sequence | 23 | Alternate CE# Controlled Erase and Program Operations | 50 |
| Enter SecSi Sector/Exit SecSi Sector Command Sequence .. | 23 | Figure 26. Alternate CE# Controlled Write (Erase/Program) | |
| Word Program Command Sequence | 23 | Operation Timings..... | 51 |
| Unlock Bypass Command Sequence | 24 | Erase And Programming Performance | 52 |
| Write Buffer Programming | 24 | Latchup Characteristics | 52 |
| Accelerated Program | 25 | TSOP Pin Capacitance | 53 |
| Figure 4. Write Buffer Programming Operation..... | 26 | Data Retention | 53 |
| Figure 5. Program Operation | 27 | Physical Dimensions | 54 |
| Program Suspend/Program Resume Command Sequence ... | 27 | TS 048—48-Pin Standard Thin Small Outline Package | 54 |
| Figure 6. Program Suspend/Program Resume..... | 28 | TSR048—48-Pin Reverse Thin Small Outline Package | 55 |
| Chip Erase Command Sequence | 28 | Revision Summary | 56 |

PRODUCT SELECTOR GUIDE

| Part Number | | Am29LV641MH/L | | | | | |
|--------------------------------------|-------------------------------------|---|--|---|--|---|--|
| Speed Option | $V_{CC} = 3.0\text{--}3.6\text{ V}$ | 90R ($V_{IO} = 3.0\text{--}3.6\text{ V}$) | 101R ($V_{IO} = 2.7\text{--}3.6\text{ V}$) | 112R ($V_{IO} = 1.65\text{--}3.6\text{ V}$) | | 120R ($V_{IO} = 1.65\text{--}3.6\text{ V}$) | |
| | $V_{CC} = 2.7\text{--}3.6\text{ V}$ | | 101 ($V_{IO} = 2.7\text{--}3.6\text{ V}$) | | 112 ($V_{IO} = 1.65\text{--}3.6\text{ V}$) | | 120 ($V_{IO} = 1.65\text{--}3.6\text{ V}$) |
| Max. Access Time (ns) | | 90 | 100 | 110 | | 120 | |
| Max. CE# Access Time (ns) | | 90 | 100 | 110 | | 120 | |
| Max. Page access time (t_{PACC}) | | 25 | 30 | 30 | 40 | 30 | 40 |
| Max. OE# Access Time (ns) | | 25 | 30 | 30 | 40 | 30 | 40 |

Notes:

1. See "AC Characteristics" for full specifications.
2. For the Am29LV641MH/L device, the last numeric digit in the speed option (e.g. 101, 112, 120) is used for internal purposes only. Please use OPNs as listed when placing orders.

BLOCK DIAGRAM

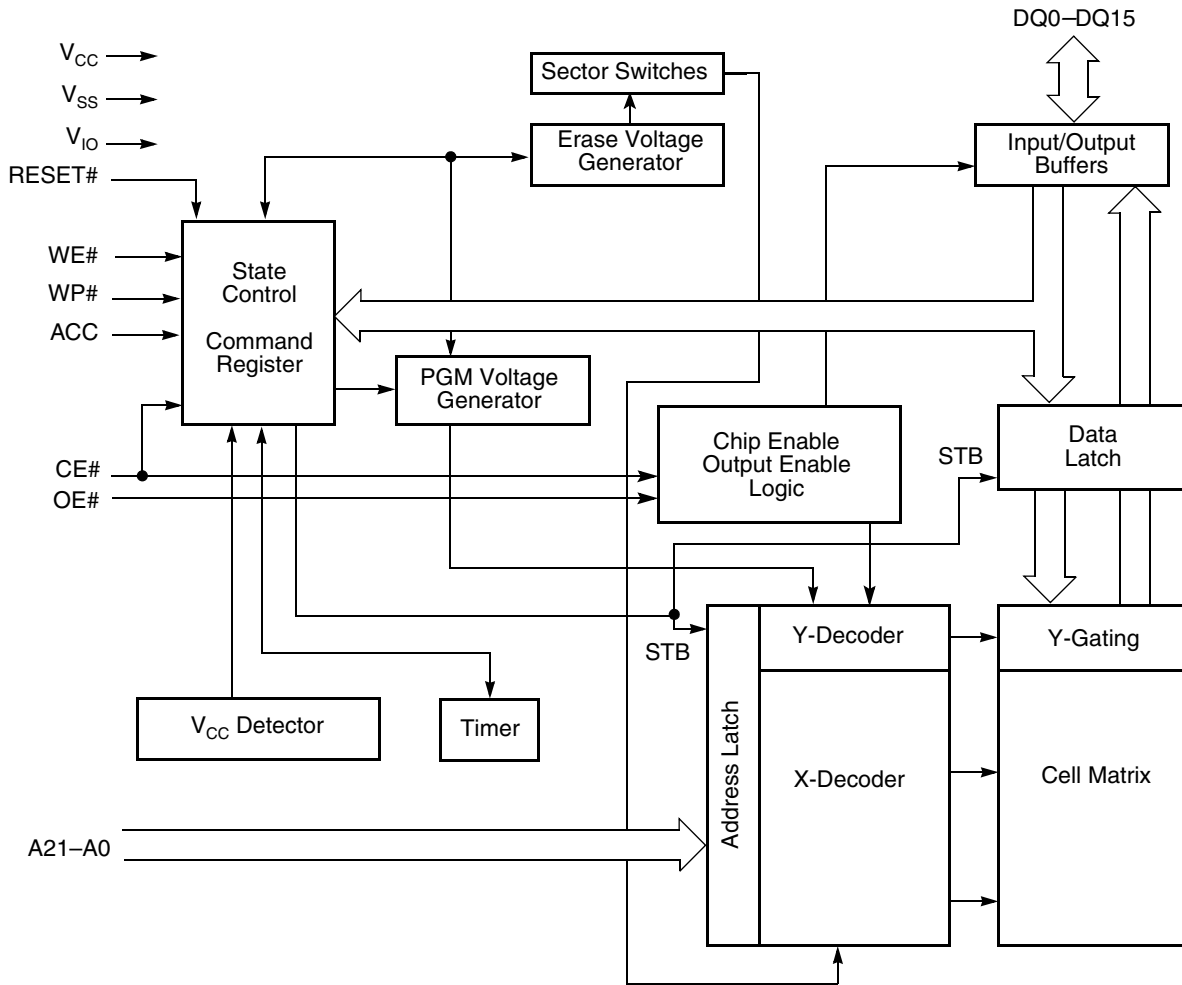

CONNECTION DIAGRAMS

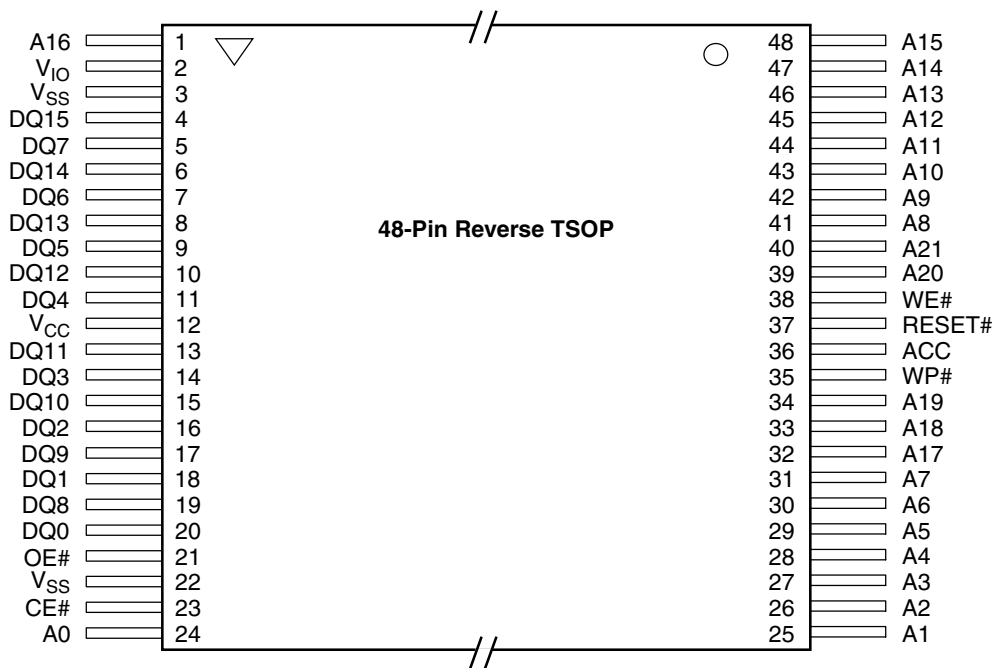
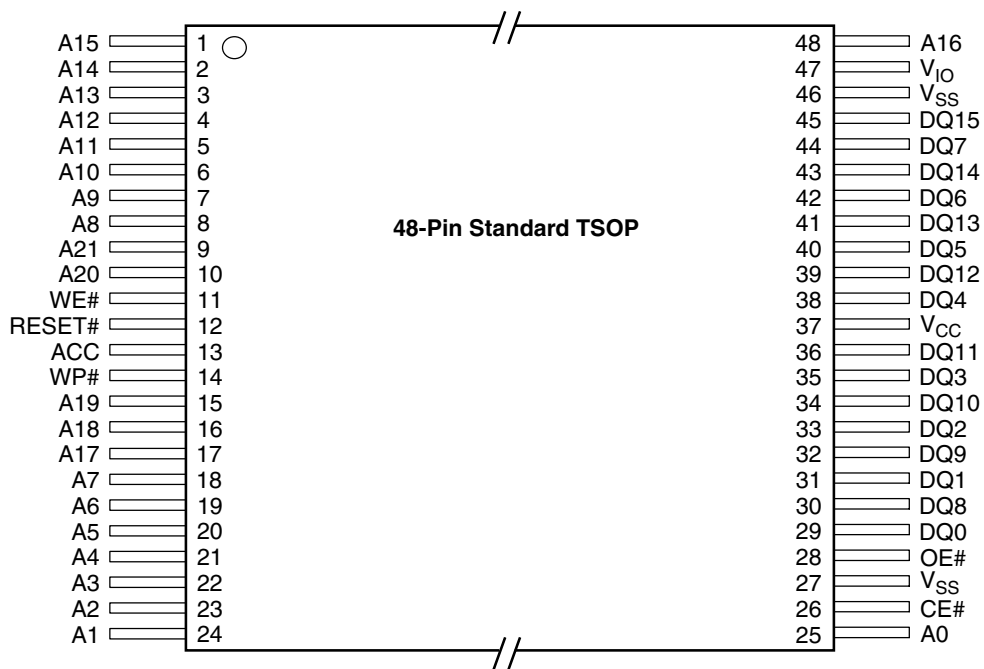

PIN DESCRIPTION

- A21–A0 = 22 Address inputs
- DQ15–DQ0 = 16 Data inputs/outputs
- CE# = Chip Enable input
- OE# = Output Enable input
- WE# = Write Enable input
- WP# = Hardware Write Protect input
- ACC = Acceleration input
- RESET# = Hardware Reset Pin input
- V_{CC} = 3.0 volt-only single power supply
(see Product Selector Guide for speed options and voltage supply tolerances)
- V_{IO} = Output Buffer power
- V_{SS} = Device Ground
- NC = Pin Not Connected Internally

LOGIC SYMBOL

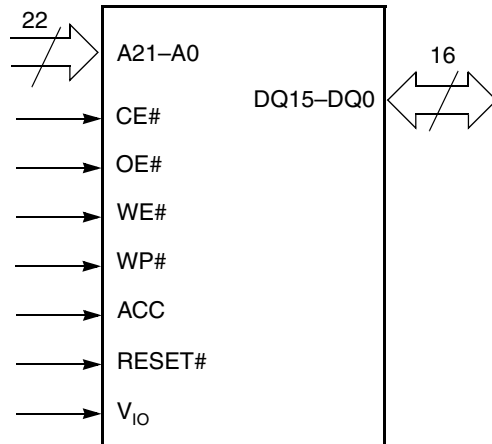

ORDERING INFORMATION

Standard Products

AMD standard products are available in several packages and operating ranges. The order number (Valid Combination) is formed by a combination of the following:

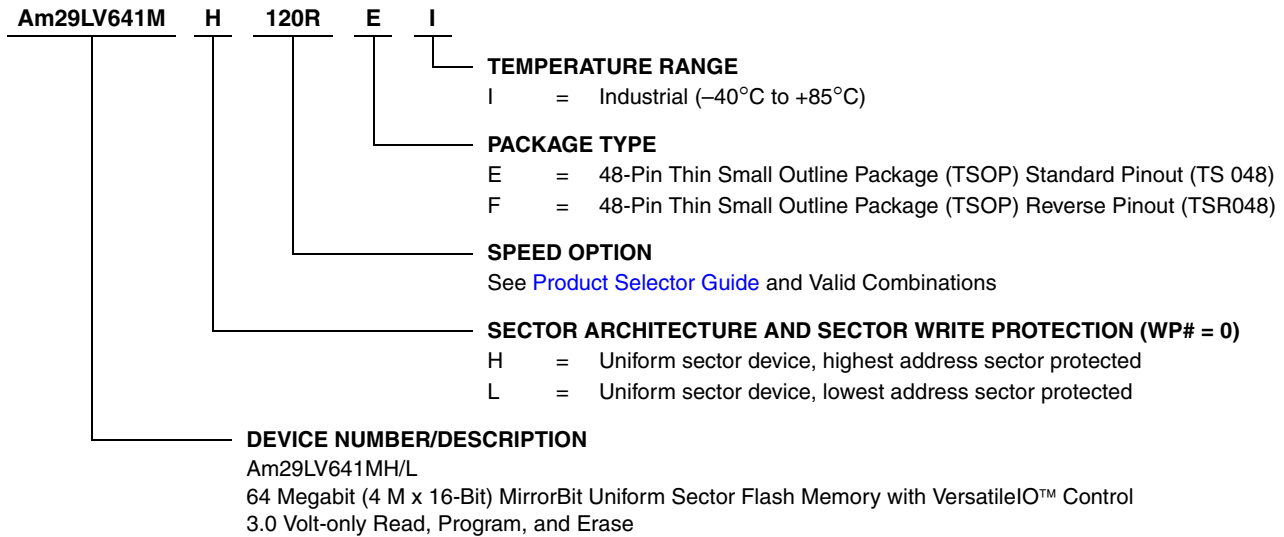

| Valid Combinations for TSOP Packages | | Speed (ns) | V _{IO} Range | V _{CC} Range |
|--------------------------------------|--------|------------|-----------------------|-----------------------|
| Am29LV641MH90R, Am29LV641ML90R | EI, FI | 90 | 3.0–3.6 V | 3.0–3.6 V |
| Am29LV641MH101, Am29LV641ML101 | | 100 | 2.7–3.6 V | 2.7–3.6 V |
| Am29LV641MH112, Am29LV641ML112 | | 110 | 1.65–3.6 V | |
| Am29LV641MH120, Am29LV641ML120 | | 120 | 1.65–3.6 V | 3.0–3.6 V |
| Am29LV641MH101R, Am29LV641ML101R | | 100 | 2.7–3.6 V | |
| Am29LV641MH112R, Am29LV641ML112R | | 110 | 1.65–3.6 V | |
| Am29LV641MH120R, Am29LV641ML120R | | 120 | 1.65–3.6 V | |

Valid Combinations

Valid Combinations list configurations planned to be supported in volume for this device. Consult the local AMD sales office to confirm availability of specific valid combinations and to check on newly released combinations.

Note:

For the Am29LV641MH/L device, the last numeric digit in the speed option (e.g. 101, 112, 120) is used for internal purposes only. Please use OPNs as listed when placing orders.

DEVICE BUS OPERATIONS

This section describes the requirements and use of the device bus operations, which are initiated through the internal command register. The command register itself does not occupy any addressable memory location. The register is a latch used to store the commands, along with the address and data information needed to execute the command. The contents of the

register serve as inputs to the internal state machine. The state machine outputs dictate the function of the device. Table 1 lists the device bus operations, the inputs and control levels they require, and the resulting output. The following subsections describe each of these operations in further detail.

Table 1. Device Bus Operations

| Operation | CE# | OE# | WE# | RESET# | WP# | ACC | Addresses (Note 2) | DQ0–DQ15 |
|----------------------------------|-------------------------|-----|-----|-------------------------|----------|-----------------|----------------------------------|------------------|
| Read | L | L | H | H | X | L/H | A _{IN} | D _{OUT} |
| Write (Program/Erase) | L | H | L | H | (Note 3) | L/H | A _{IN} | (Note 4) |
| Accelerated Program | L | H | L | H | (Note 3) | V _{HH} | A _{IN} | (Note 4) |
| Standby | V _{CC} ± 0.3 V | X | X | V _{CC} ± 0.3 V | X | H | X | High-Z |
| Output Disable | L | H | H | H | X | L/H | X | High-Z |
| Reset | X | X | X | L | X | L/H | X | High-Z |
| Sector Group Protect (Note 2) | L | H | L | V _{ID} | H | L/H | SA, A6=L, A3=L, A2=L, A1=H, A0=L | (Note 4) |
| Sector Group Unprotect (Note 2) | L | H | L | V _{ID} | H | L/H | SA, A6=H, A3=L, A2=L, A1=H, A0=L | (Note 4) |
| Temporary Sector Group Unprotect | X | X | X | V _{ID} | H | L/H | A _{IN} | (Note 4) |

Legend: L = Logic Low = V_{IL}, H = Logic High = V_{IH}, V_{ID} = 11.5–12.5 V, V_{HH} = 11.5–12.5 V, X = Don't Care, SA = Sector Address, A_{IN} = Address In, D_{IN} = Data In, D_{OUT} = Data Out

Notes:

1. Addresses are A21:A0. Sector addresses are A21:A15.
2. The sector protect and sector unprotect functions may also be implemented via programming equipment. See the “Sector Group Protection and Unprotection” section.
3. If WP# = V_{IL}, the first or last sector remains protected. If WP# = V_{IH}, the first or last sector will be protected or unprotected as determined by the method described in “Sector Group Protection and Unprotection”. All sectors are unprotected when shipped from the factory (The SecSi Sector may be factory protected depending on version ordered.)
4. D_{IN} or D_{OUT} as required by command sequence, data polling, or sector protect algorithm (see Figure 2).

VersatileIO™ (V_{IO}) Control

The VersatileIO™ (V_{IO}) control allows the host system to set the voltage levels that the device generates and tolerates on CE# and DQ I/Os to the same voltage level that is asserted on V_{IO}. See “Ordering Information” on page 8 for V_{IO} options on this device.

For example, a V_{IO} of 1.65–3.6 volts allows for I/O at the 1.8 or 3 volt levels, driving and receiving signals to and from other 1.8 or 3 V devices on the same data bus.

Requirements for Reading Array Data

To read array data from the outputs, the system must drive the CE# and OE# pins to V_{IL}. CE# is the power control and selects the device. OE# is the output control and gates array data to the output pins. WE# should remain at V_{IH}.

The internal state machine is set for reading array data upon device power-up, or after a hardware reset. This ensures that no spurious alteration of the memory content occurs during the power transition. No command is necessary in this mode to obtain array data. Standard microprocessor read cycles that assert valid addresses on the device address inputs produce valid

data on the device data outputs. The device remains enabled for read access until the command register contents are altered.

See “Reading Array Data” for more information. Refer to the AC [Read-Only Operations](#) table for timing specifications and to Figure 14 for the timing diagram. Refer to the DC Characteristics table for the active current specification on reading array data.

Page Mode Read

The device is capable of fast page mode read and is compatible with the page mode Mask ROM read operation. This mode provides faster read access speed for random locations within a page. The page size of the device is 4 words. The appropriate page is selected by the higher address bits A(max)–A2. Address bits A1–A0 determine the specific word within a page. This is an asynchronous operation; the microprocessor supplies the specific word location.

The random or initial page access is equal to t_{ACC} or t_{CE} and subsequent page read accesses (as long as the locations specified by the microprocessor falls within that page) is equivalent to t_{PACC} . When CE# is deasserted and reasserted for a subsequent access, the access time is t_{ACC} or t_{CE} . Fast page mode accesses are obtained by keeping the “read-page addresses” constant and changing the “intra-read page” addresses.

Writing Commands/Command Sequences

To write a command or command sequence (which includes programming data to the device and erasing sectors of memory), the system must drive WE# and CE# to V_{IL} , and OE# to V_{IH} .

The device features an **Unlock Bypass** mode to facilitate faster programming. Once the device enters the Unlock Bypass mode, only two write cycles are required to program a word, instead of four. The “Word Program Command Sequence” section has details on programming data to the device using both standard and Unlock Bypass command sequences.

An erase operation can erase one sector, multiple sectors, or the entire device. Table 2 indicates the address space that each sector occupies.

Refer to the DC Characteristics table for the active current specification for the write mode. The [AC Characteristics](#) section contains timing specification tables and timing diagrams for write operations.

Write Buffer

Write Buffer Programming allows the system to write a maximum of 16 words in one programming operation. This results in faster effective programming time than the standard programming algorithms. See “Write Buffer” for more information.

Accelerated Program Operation

The device offers accelerated program operations through the ACC function. This function is primarily intended to allow faster manufacturing throughput during system production.

If the system asserts V_{HH} on this pin, the device automatically enters the aforementioned Unlock Bypass mode, temporarily unprotects any protected sectors, and uses the higher voltage on the pin to reduce the time required for program operations. The system would use a two-cycle program command sequence as required by the Unlock Bypass mode. Removing V_{HH} from the ACC pin returns the device to normal operation. *Note that the ACC pin must not be at V_{HH} for operations other than accelerated programming, or device damage may result.*

Autoselect Functions

If the system writes the autoselect command sequence, the device enters the autoselect mode. The system can then read autoselect codes from the internal register (which is separate from the memory array) on DQ7–DQ0. Standard read cycle timings apply in this mode. Refer to the [Autoselect Mode](#) and [Autoselect Command Sequence](#) sections for more information.

Standby Mode

When the system is not reading or writing to the device, it can place the device in the standby mode. In this mode, current consumption is greatly reduced, and the outputs are placed in the high impedance state, independent of the OE# input.

The device enters the CMOS standby mode when the CE# and RESET# pins are both held at $V_{IO} \pm 0.3$ V. (Note that this is a more restricted voltage range than V_{IH} .) If CE# and RESET# are held at V_{IH} , but not within $V_{IO} \pm 0.3$ V, the device will be in the standby mode, but the standby current will be greater. The device requires standard access time (t_{CE}) for read access when the device is in either of these standby modes, before it is ready to read data.

If the device is deselected during erasure or programming, the device draws active current until the operation is completed.

Refer to the [DC Characteristics](#) table for the standby current specification.

Automatic Sleep Mode

The automatic sleep mode minimizes Flash device energy consumption. The device automatically enables this mode when addresses remain stable for $t_{ACC} + 30$ ns. The automatic sleep mode is independent of the CE#, WE#, and OE# control signals. Standard address access timings provide new data when ad-

addresses are changed. While in sleep mode, output data is latched and always available to the system. Refer to the [DC Characteristics](#) table for the automatic sleep mode current specification.

RESET#: Hardware Reset Pin

The RESET# pin provides a hardware method of resetting the device to reading array data. When the RESET# pin is driven low for at least a period of t_{RP} the device immediately terminates any operation in progress, tristates all output pins, and ignores all read/write commands for the duration of the RESET# pulse. The device also resets the internal state machine to reading array data. The operation that was interrupted should be reinitiated once the device is ready to accept another command sequence, to ensure data integrity.

Current is reduced for the duration of the RESET# pulse. When RESET# is held at $V_{SS} \pm 0.3$ V, the device draws CMOS standby current (I_{CC4}). If RESET# is held at V_{IL} but not within $V_{SS} \pm 0.3$ V, the standby current will be greater.

The RESET# pin may be tied to the system reset circuitry. A system reset would thus also reset the Flash memory, enabling the system to read the boot-up firmware from the Flash memory.

Refer to the [AC Characteristics](#) tables for RESET# parameters and to Figure 17 for the timing diagram.

Output Disable Mode

When the OE# input is at V_{IH} , output from the device is disabled. The output pins are placed in the high impedance state.

Table 2. Sector Address Table

| Sector | A21–A15 | | | | | | | 16-bit Address Range (in hexadecimal) | Sector | A21–A15 | | | | | | | 16-bit Address Range (in hexadecimal) |
|--------|---------|---|---|---|---|---|---|---------------------------------------|--------|---------|---|---|---|---|---|---|---------------------------------------|
| SA0 | 0 | 0 | 0 | 0 | 0 | 0 | 0 | 000000–007FFF | SA32 | 0 | 1 | 0 | 0 | 0 | 0 | 0 | 100000–107FFF |
| SA1 | 0 | 0 | 0 | 0 | 0 | 0 | 1 | 008000–00FFFF | SA33 | 0 | 1 | 0 | 0 | 0 | 0 | 1 | 108000–10FFFF |
| SA2 | 0 | 0 | 0 | 0 | 0 | 1 | 0 | 010000–017FFF | SA34 | 0 | 1 | 0 | 0 | 0 | 1 | 0 | 110000–117FFF |
| SA3 | 0 | 0 | 0 | 0 | 0 | 1 | 1 | 018000–01FFFF | SA35 | 0 | 1 | 0 | 0 | 0 | 1 | 1 | 118000–11FFFF |
| SA4 | 0 | 0 | 0 | 0 | 1 | 0 | 0 | 020000–027FFF | SA36 | 0 | 1 | 0 | 0 | 1 | 0 | 0 | 120000–127FFF |
| SA5 | 0 | 0 | 0 | 0 | 1 | 0 | 1 | 028000–02FFFF | SA37 | 0 | 1 | 0 | 0 | 1 | 0 | 1 | 128000–12FFFF |
| SA6 | 0 | 0 | 0 | 0 | 1 | 1 | 0 | 030000–037FFF | SA38 | 0 | 1 | 0 | 0 | 1 | 1 | 0 | 130000–137FFF |
| SA7 | 0 | 0 | 0 | 0 | 1 | 1 | 1 | 038000–03FFFF | SA39 | 0 | 1 | 0 | 0 | 1 | 1 | 1 | 138000–13FFFF |
| SA8 | 0 | 0 | 0 | 1 | 0 | 0 | 0 | 040000–047FFF | SA40 | 0 | 1 | 0 | 1 | 0 | 0 | 0 | 140000–147FFF |
| SA9 | 0 | 0 | 0 | 1 | 0 | 0 | 1 | 048000–04FFFF | SA41 | 0 | 1 | 0 | 1 | 0 | 0 | 1 | 148000–14FFFF |
| SA10 | 0 | 0 | 0 | 1 | 0 | 1 | 0 | 050000–057FFF | SA42 | 0 | 1 | 0 | 1 | 0 | 1 | 0 | 150000–157FFF |
| SA11 | 0 | 0 | 0 | 1 | 0 | 1 | 1 | 058000–05FFFF | SA43 | 0 | 1 | 0 | 1 | 0 | 1 | 1 | 158000–15FFFF |
| SA12 | 0 | 0 | 0 | 1 | 1 | 0 | 0 | 060000–067FFF | SA44 | 0 | 1 | 0 | 1 | 1 | 0 | 0 | 160000–167FFF |
| SA13 | 0 | 0 | 0 | 1 | 1 | 0 | 1 | 068000–06FFFF | SA45 | 0 | 1 | 0 | 1 | 1 | 0 | 1 | 168000–16FFFF |
| SA14 | 0 | 0 | 0 | 1 | 1 | 1 | 0 | 070000–077FFF | SA46 | 0 | 1 | 0 | 1 | 1 | 1 | 0 | 170000–177FFF |
| SA15 | 0 | 0 | 0 | 1 | 1 | 1 | 1 | 078000–07FFFF | SA47 | 0 | 1 | 0 | 1 | 1 | 1 | 1 | 178000–17FFFF |
| SA16 | 0 | 0 | 1 | 0 | 0 | 0 | 0 | 080000–087FFF | SA48 | 0 | 1 | 1 | 0 | 0 | 0 | 0 | 180000–187FFF |
| SA17 | 0 | 0 | 1 | 0 | 0 | 0 | 1 | 088000–08FFFF | SA49 | 0 | 1 | 1 | 0 | 0 | 0 | 1 | 188000–18FFFF |
| SA18 | 0 | 0 | 1 | 0 | 0 | 1 | 0 | 090000–097FFF | SA50 | 0 | 1 | 1 | 0 | 0 | 1 | 0 | 190000–197FFF |
| SA19 | 0 | 0 | 1 | 0 | 0 | 1 | 1 | 098000–09FFFF | SA51 | 0 | 1 | 1 | 0 | 0 | 1 | 1 | 198000–19FFFF |
| SA20 | 0 | 0 | 1 | 0 | 1 | 0 | 0 | 0A0000–0A7FFF | SA52 | 0 | 1 | 1 | 0 | 1 | 0 | 0 | 1A0000–1A7FFF |
| SA21 | 0 | 0 | 1 | 0 | 1 | 0 | 1 | 0A8000–0AFFFF | SA53 | 0 | 1 | 1 | 0 | 1 | 0 | 1 | 1A8000–1AFFFF |
| SA22 | 0 | 0 | 1 | 0 | 1 | 1 | 0 | 0B0000–0B7FFF | SA54 | 0 | 1 | 1 | 0 | 1 | 1 | 0 | 1B0000–1B7FFF |
| SA23 | 0 | 0 | 1 | 0 | 1 | 1 | 1 | 0B8000–0BFFFF | SA55 | 0 | 1 | 1 | 0 | 1 | 1 | 1 | 1B8000–1BFFFF |
| SA24 | 0 | 0 | 1 | 1 | 0 | 0 | 0 | 0C0000–0C7FFF | SA56 | 0 | 1 | 1 | 1 | 0 | 0 | 0 | 1C0000–1C7FFF |
| SA25 | 0 | 0 | 1 | 1 | 0 | 0 | 1 | 0C8000–0CFFFF | SA57 | 0 | 1 | 1 | 1 | 0 | 0 | 1 | 1C8000–1CFFFF |
| SA26 | 0 | 0 | 1 | 1 | 0 | 1 | 0 | 0D0000–0D7FFF | SA58 | 0 | 1 | 1 | 1 | 0 | 1 | 0 | 1D0000–1D7FFF |
| SA27 | 0 | 0 | 1 | 1 | 0 | 1 | 1 | 0D8000–0DFFFF | SA59 | 0 | 1 | 1 | 1 | 0 | 1 | 1 | 1D8000–1DFFFF |
| SA28 | 0 | 0 | 1 | 1 | 1 | 0 | 0 | 0E0000–0E7FFF | SA60 | 0 | 1 | 1 | 1 | 1 | 0 | 0 | 1E0000–1E7FFF |
| SA29 | 0 | 0 | 1 | 1 | 1 | 0 | 1 | 0E8000–0EFFFF | SA61 | 0 | 1 | 1 | 1 | 1 | 0 | 1 | 1E8000–1EFFFF |
| SA30 | 0 | 0 | 1 | 1 | 1 | 1 | 0 | 0F0000–0F7FFF | SA62 | 0 | 1 | 1 | 1 | 1 | 1 | 0 | 1F0000–1F7FFF |
| SA31 | 0 | 0 | 1 | 1 | 1 | 1 | 1 | 0F8000–0FFFFF | SA63 | 0 | 1 | 1 | 1 | 1 | 1 | 1 | 1F8000–1FFFFF |
| SA64 | 1 | 0 | 0 | 0 | 0 | 0 | 0 | 200000–207FFF | SA96 | 1 | 1 | 0 | 0 | 0 | 0 | 0 | 300000–307FFF |
| SA65 | 1 | 0 | 0 | 0 | 0 | 0 | 1 | 208000–20FFFF | SA97 | 1 | 1 | 0 | 0 | 0 | 0 | 1 | 308000–30FFFF |
| SA66 | 1 | 0 | 0 | 0 | 0 | 1 | 0 | 210000–217FFF | SA98 | 1 | 1 | 0 | 0 | 0 | 1 | 0 | 310000–317FFF |
| SA67 | 1 | 0 | 0 | 0 | 0 | 1 | 1 | 218000–21FFFF | SA99 | 1 | 1 | 0 | 0 | 0 | 1 | 1 | 318000–31FFFF |
| SA68 | 1 | 0 | 0 | 0 | 1 | 0 | 0 | 220000–227FFF | SA100 | 1 | 1 | 0 | 0 | 1 | 0 | 0 | 320000–327FFF |
| SA69 | 1 | 0 | 0 | 0 | 1 | 0 | 1 | 228000–22FFFF | SA101 | 1 | 1 | 0 | 0 | 1 | 0 | 1 | 328000–32FFFF |
| SA70 | 1 | 0 | 0 | 0 | 1 | 1 | 0 | 230000–237FFF | SA102 | 1 | 1 | 0 | 0 | 1 | 1 | 0 | 330000–337FFF |
| SA71 | 1 | 0 | 0 | 0 | 1 | 1 | 1 | 238000–23FFFF | SA103 | 1 | 1 | 0 | 0 | 1 | 1 | 1 | 338000–33FFFF |
| SA72 | 1 | 0 | 0 | 1 | 0 | 0 | 0 | 240000–247FFF | SA104 | 1 | 1 | 0 | 1 | 0 | 0 | 0 | 340000–347FFF |
| SA73 | 1 | 0 | 0 | 1 | 0 | 0 | 1 | 248000–24FFFF | SA105 | 1 | 1 | 0 | 1 | 0 | 0 | 1 | 348000–34FFFF |
| SA74 | 1 | 0 | 0 | 1 | 0 | 1 | 0 | 250000–257FFF | SA106 | 1 | 1 | 0 | 1 | 0 | 1 | 0 | 350000–357FFF |
| SA75 | 1 | 0 | 0 | 1 | 0 | 1 | 1 | 258000–25FFFF | SA107 | 1 | 1 | 0 | 1 | 0 | 1 | 1 | 358000–35FFFF |

Table 2. Sector Address Table (Continued)

| Sector | A21–A15 | | | | | | | 16-bit Address Range (in hexadecimal) | Sector | A21–A15 | | | | | | | 16-bit Address Range (in hexadecimal) |
|--------|---------|---|---|---|---|---|---|---------------------------------------|--------|---------|---|---|---|---|---|---|---------------------------------------|
| | | | | | | | | | | | | | | | | | |
| SA76 | 1 | 0 | 0 | 1 | 1 | 0 | 0 | 260000–267FFF | SA108 | 1 | 1 | 0 | 1 | 1 | 0 | 0 | 360000–367FFF |
| SA77 | 1 | 0 | 0 | 1 | 1 | 0 | 1 | 268000–26FFFF | SA109 | 1 | 1 | 0 | 1 | 1 | 0 | 1 | 368000–36FFFF |
| SA78 | 1 | 0 | 0 | 1 | 1 | 1 | 0 | 270000–277FFF | SA110 | 1 | 1 | 0 | 1 | 1 | 1 | 0 | 370000–377FFF |
| SA79 | 1 | 0 | 0 | 1 | 1 | 1 | 1 | 278000–27FFFF | SA111 | 1 | 1 | 0 | 1 | 1 | 1 | 1 | 378000–37FFFF |
| SA80 | 1 | 0 | 1 | 0 | 0 | 0 | 0 | 280000–287FFF | SA112 | 1 | 1 | 1 | 0 | 0 | 0 | 0 | 380000–387FFF |
| SA81 | 1 | 0 | 1 | 0 | 0 | 0 | 1 | 288000–28FFFF | SA113 | 1 | 1 | 1 | 0 | 0 | 0 | 1 | 388000–38FFFF |
| SA82 | 1 | 0 | 1 | 0 | 0 | 1 | 0 | 290000–297FFF | SA114 | 1 | 1 | 1 | 0 | 0 | 1 | 0 | 390000–397FFF |
| SA83 | 1 | 0 | 1 | 0 | 0 | 1 | 1 | 298000–29FFFF | SA115 | 1 | 1 | 1 | 0 | 0 | 1 | 1 | 398000–39FFFF |
| SA84 | 1 | 0 | 1 | 0 | 1 | 0 | 0 | 2A0000–2A7FFF | SA116 | 1 | 1 | 1 | 0 | 1 | 0 | 0 | 3A0000–3A7FFF |
| SA85 | 1 | 0 | 1 | 0 | 1 | 0 | 1 | 2A8000–2AFFFF | SA117 | 1 | 1 | 1 | 0 | 1 | 0 | 1 | 3A8000–3AFFFF |
| SA86 | 1 | 0 | 1 | 0 | 1 | 1 | 0 | 2B0000–2B7FFF | SA118 | 1 | 1 | 1 | 0 | 1 | 1 | 0 | 3B0000–3B7FFF |
| SA87 | 1 | 0 | 1 | 0 | 1 | 1 | 1 | 2B8000–2BFFFF | SA119 | 1 | 1 | 1 | 0 | 1 | 1 | 1 | 3B8000–3BFFFF |
| SA88 | 1 | 0 | 1 | 1 | 0 | 0 | 0 | 2C0000–2C7FFF | SA120 | 1 | 1 | 1 | 1 | 0 | 0 | 0 | 3C0000–3C7FFF |
| SA89 | 1 | 0 | 1 | 1 | 0 | 0 | 1 | 2C8000–2CFFFF | SA121 | 1 | 1 | 1 | 1 | 0 | 0 | 1 | 3C8000–3CFFFF |
| SA90 | 1 | 0 | 1 | 1 | 0 | 1 | 0 | 2D0000–2D7FFF | SA122 | 1 | 1 | 1 | 1 | 0 | 1 | 0 | 3D0000–3D7FFF |
| SA91 | 1 | 0 | 1 | 1 | 0 | 1 | 1 | 2D8000–2DFFFF | SA123 | 1 | 1 | 1 | 1 | 0 | 1 | 1 | 3D8000–3DFFFF |
| SA92 | 1 | 0 | 1 | 1 | 1 | 0 | 0 | 2E0000–2E7FFF | SA124 | 1 | 1 | 1 | 1 | 1 | 0 | 0 | 3E0000–3E7FFF |
| SA93 | 1 | 0 | 1 | 1 | 1 | 0 | 1 | 2E8000–2EFFFF | SA125 | 1 | 1 | 1 | 1 | 1 | 0 | 1 | 3E8000–3EFFFF |
| SA94 | 1 | 0 | 1 | 1 | 1 | 1 | 0 | 2F0000–2F7FFF | SA126 | 1 | 1 | 1 | 1 | 1 | 1 | 0 | 3F0000–3F7FFF |
| SA95 | 1 | 0 | 1 | 1 | 1 | 1 | 1 | 2F8000–2FFFFF | SA127 | 1 | 1 | 1 | 1 | 1 | 1 | 1 | 3F8000–3FFFFF |

Note: All sectors are 32 Kwords in size.

Autoselect Mode

The autoselect mode provides manufacturer and device identification, and sector protection verification, through identifier codes output on DQ7–DQ0. This mode is primarily intended for programming equipment to automatically match a device to be programmed with its corresponding programming algorithm. However, the autoselect codes can also be accessed in-system through the command register.

When using programming equipment, the autoselect mode requires V_{ID} on address pin A9. Address pins A6, A3, A2, A1, and A0 must be as shown in Table 3.

In addition, when verifying sector protection, the sector address must appear on the appropriate highest order address bits (see Table 2). Table 3 shows the remaining address bits that are don't care. When all necessary bits have been set as required, the programming equipment may then read the corresponding identifier code on DQ7–DQ0.

To access the autoselect codes in-system, the host system can issue the autoselect command via the command register, as shown in Table 10. This method does not require V_{ID} . Refer to the [Autoselect Command Sequence](#) section for more information.

Table 3. Autoselect Codes, (High Voltage Method)

| Description | CE# | OE# | WE# | A21 to A15 | A14 to A10 | A9 | A8 to A7 | A6 | A5 to A4 | A3 to A2 | A1 | A0 | DQ15 to DQ0 | | |
|---|---------|-----|-----|------------|------------|----------|----------|----------|----------|----------|----|----|---|-------|-------|
| Manufacturer ID: AMD | L | L | H | X | X | V_{ID} | X | L | X | L | L | L | 0001h | | |
| Device ID | Cycle 1 | | | | | | | | | L | L | H | 227Eh | | |
| | Cycle 2 | | L | L | H | X | X | V_{ID} | X | L | X | H | H | L | 2213h |
| | Cycle 3 | | | | | | | | | | H | H | H | 2201h | |
| Sector Protection Verification | L | L | H | SA | X | V_{ID} | X | L | X | L | H | L | XX01h (protected), XX00h (unprotected) | | |
| SecSi Sector Indicator Bit (DQ7), WP# protects highest address sector | L | L | H | X | X | V_{ID} | X | L | X | L | H | H | XX98h (factory locked), XX18h (not factory locked) | | |
| SecSi Sector Indicator Bit (DQ7), WP# protects lowest address sector | L | L | H | X | X | V_{ID} | X | L | X | L | H | H | XX88h (factory locked), XX08h (not factory locked) | | |

Legend: L = Logic Low = V_{IL} , H = Logic High = V_{IH} , SA = Sector Address, X = Don't care.

Sector Group Protection and Unprotection

The hardware sector group protection feature disables both program and erase operations in any sector group. In this device, a sector group consists of four adjacent sectors that are protected or unprotected at the same time (see Table 4). The hardware sector group unprotection feature re-enables both program and erase operations in previously protected sector groups. Sector group protection/unprotection can be implemented via two methods.

Sector protection/unprotection requires V_{ID} on the RESET# pin only, and can be implemented either in-system or via programming equipment. Figure 2 shows the algorithms and Figure 25 shows the timing diagram. This method uses standard microprocessor bus cycle timing. For sector group unprotect, all unprotected sector groups must first be protected prior to the first sector group unprotect write cycle.

The device is shipped with all sector groups unprotected. AMD offers the option of programming and protecting sector groups at its factory prior to shipping the device through AMD's ExpressFlash™ Service. Contact an AMD representative for details.

It is possible to determine whether a sector group is protected or unprotected. See the [Autoselect Mode](#) section for details.

Table 4. Sector Group Protection/Unprotection Address Table

| Sector Group | A21–A17 |
|--------------|---------|
| SA0–SA3 | 00000 |
| SA4–SA7 | 00001 |
| SA8–SA11 | 00010 |
| SA12–SA15 | 00011 |
| SA16–SA19 | 00100 |
| SA20–SA23 | 00101 |
| SA24–SA27 | 00110 |
| SA28–SA31 | 00111 |
| SA32–SA35 | 01000 |
| SA36–SA39 | 01001 |
| SA40–SA43 | 01010 |
| SA44–SA47 | 01011 |
| SA48–SA51 | 01100 |
| SA52–SA55 | 01101 |
| SA56–SA59 | 01110 |
| SA60–SA63 | 01111 |
| SA64–SA67 | 10000 |
| SA68–SA71 | 10001 |
| SA72–SA75 | 10010 |
| SA76–SA79 | 10011 |
| SA80–SA83 | 10100 |
| SA84–SA87 | 10101 |
| SA88–SA91 | 10110 |
| SA92–SA95 | 10111 |
| SA96–SA99 | 11000 |
| SA100–SA103 | 11001 |
| SA104–SA107 | 11010 |
| SA108–SA111 | 11011 |
| SA112–SA115 | 11100 |
| SA116–SA119 | 11101 |
| SA120–SA123 | 11110 |
| SA124–SA127 | 11111 |

Note: All sector groups are 128 Kwords in size.

Write Protect (WP#)

The Write Protect function provides a hardware method of protecting the first or last sector without using V_{ID} .

If the system asserts V_{IL} on the WP# pin, the device disables program and erase functions in the first or last sector independently of whether those sectors were protected or unprotected using the method described in "Sector Group Protection and Unprotection". Note that if WP# is at V_{IL} when the device is in the standby mode, the maximum input load current is increased. See the table in "DC Characteristics".

If the system asserts V_{IH} on the WP# pin, the device reverts to whether the first or last sector was previously set to be protected or unprotected using the method described in "Sector Group Protection and Unprotection".

Temporary Sector Group Unprotect

Note: In this device, a sector group consists of four adjacent sectors that are protected or unprotected at the same time (see Table 4).

This feature allows temporary unprotection of previously protected sector groups to change data in-system. The Sector Group Unprotect mode is activated by setting the RESET# pin to V_{ID} . During this mode, formerly protected sector groups can be programmed or erased by selecting the sector group addresses. Once V_{ID} is removed from the RESET# pin, all the previously protected sector groups are protected again. Figure 1 shows the algorithm, and Figure 24 shows the timing diagrams, for this feature.

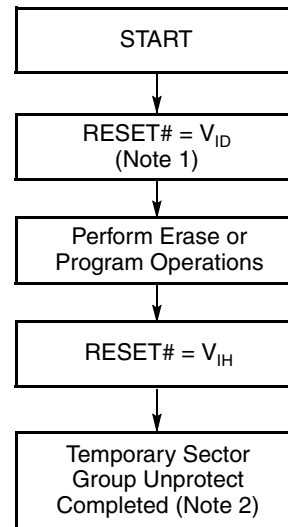

Notes:

1. All protected sector groups unprotected (If WP# = V_{IL} , the first or last sector will remain protected).
2. All previously protected sector groups are protected once again.

Figure 1. Temporary Sector Group Unprotect Operation

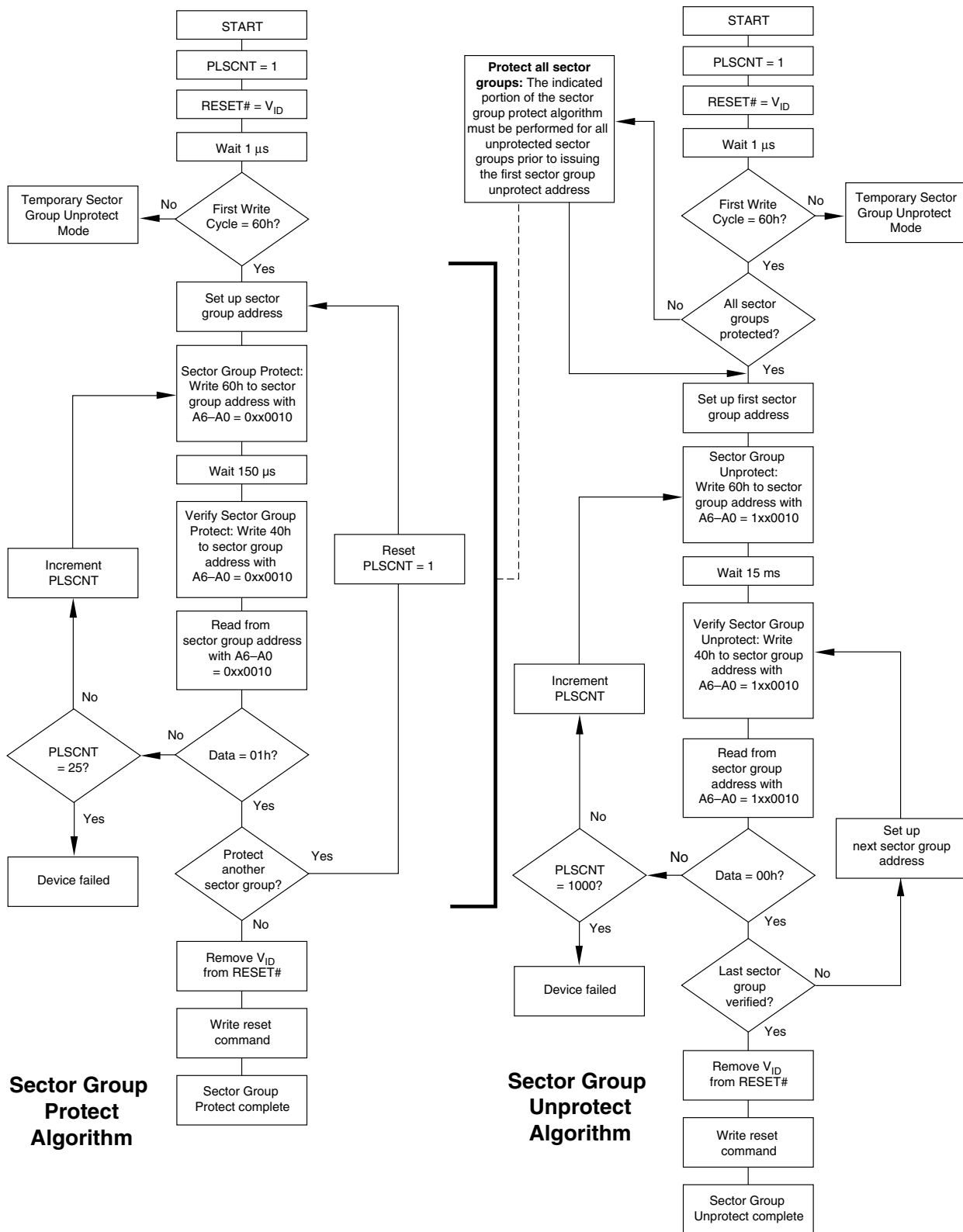

Figure 2. In-System Sector Group Protect/Unprotect Algorithms

SecSi (Secured Silicon) Sector Flash Memory Region

The SecSi (Secured Silicon) Sector feature provides a Flash memory region that enables permanent part identification through an Electronic Serial Number (ESN). The SecSi Sector is 128 words in length, and uses a SecSi Sector Indicator Bit (DQ7) to indicate whether or not the SecSi Sector is locked when shipped from the factory. This bit is permanently set at the factory and cannot be changed, which prevents cloning of a factory locked part. This ensures the security of the ESN once the product is shipped to the field.

AMD offers the device with the SecSi Sector either factory locked or customer lockable. The factory-locked version is always protected when shipped from the factory, and has the SecSi (Secured Silicon) Sector Indicator Bit permanently set to a “1.” The customer-lockable version is shipped with the SecSi Sector unprotected, allowing customers to program the sector after receiving the device. The customer-lockable version also has the SecSi Sector Indicator Bit permanently set to a “0.” Thus, the SecSi Sector Indicator Bit prevents customer-lockable devices from being used to replace devices that are factory locked.

The SecSi sector address space in this device is allocated as follows:

Table 5. SecSi Sector Contents

| SecSi Sector Address Range | Standard Factory Locked | ExpressFlash Factory Locked | Customer Lockable |
|----------------------------|-------------------------|-------------------------------|------------------------|
| 000000h–000007h | ESN | ESN or determined by customer | Determined by customer |
| 000008h–00007Fh | Unavailable | Determined by customer | |

The system accesses the SecSi Sector through a command sequence (see “Enter SecSi Sector/Exit SecSi Sector Command Sequence”). After the system has written the Enter SecSi Sector command sequence, it may read the SecSi Sector by using the addresses normally occupied by the first sector (SA0). This mode of operation continues until the system issues the Exit SecSi Sector command sequence, or until power is removed from the device. On power-up, or following a hardware reset, the device reverts to sending commands to sector SA0.

Factory Locked: SecSi Sector Programmed and Protected At the Factory

In devices with an ESN, the SecSi Sector is protected when the device is shipped from the factory. The SecSi Sector cannot be modified in any way. A factory locked device has an 8-word random ESN at addresses 000000h–000007h.

Customers may opt to have their code programmed by AMD through the AMD ExpressFlash service. The devices are then shipped from AMD’s factory with the SecSi Sector permanently locked. Contact an AMD representative for details on using AMD’s ExpressFlash service.

Customer Lockable: SecSi Sector NOT Programmed or Protected At the Factory

As an alternative to the factory-locked version, the device may be ordered such that the customer may program and protect the 128-word SecSi sector.

The system may program the SecSi Sector using the write-buffer, accelerated and/or unlock bypass methods, in addition to the standard programming command sequence. See [Command Definitions](#).

Programming and protecting the SecSi Sector must be used with caution since, once protected, there is no procedure available for unprotecting the SecSi Sector area and none of the bits in the SecSi Sector memory space can be modified in any way.

The SecSi Sector area can be protected using one of the following procedures:

- Write the three-cycle Enter SecSi Sector Region command sequence, and then follow the in-system sector protect algorithm as shown in Figure 2, except that *RESET#* may be at either V_{IH} or V_{ID} . This allows in-system protection of the SecSi Sector without raising any device pin to a high voltage. Note that this method is only applicable to the SecSi Sector.
- To verify the protect/unprotect status of the SecSi Sector, follow the algorithm shown in Figure 3.

Once the SecSi Sector is programmed, locked and verified, the system must write the Exit SecSi Sector Region command sequence to return to reading and writing within the remainder of the array.

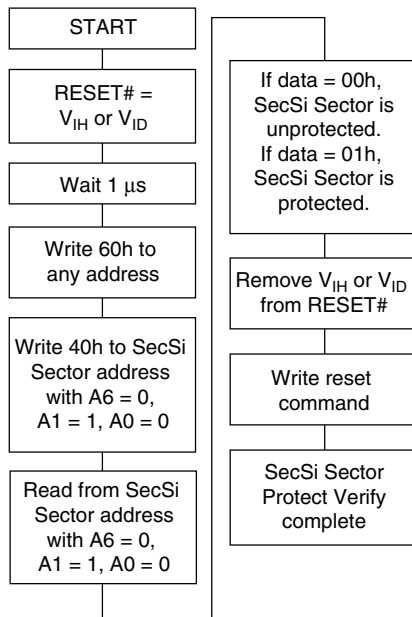

Figure 3. SecSi Sector Protect Verify

Hardware Data Protection

The command sequence requirement of unlock cycles for programming or erasing provides data protection against inadvertent writes (refer to Table 10 for command definitions). In addition, the following hardware

data protection measures prevent accidental erasure or programming, which might otherwise be caused by spurious system level signals during V_{CC} power-up and power-down transitions, or from system noise.

Low V_{CC} Write Inhibit

When V_{CC} is less than V_{LKO} , the device does not accept any write cycles. This protects data during V_{CC} power-up and power-down. The command register and all internal program/erase circuits are disabled, and the device resets to the read mode. Subsequent writes are ignored until V_{CC} is greater than V_{LKO} . The system must provide the proper signals to the control pins to prevent unintentional writes when V_{CC} is greater than V_{LKO} .

Write Pulse “Glitch” Protection

Noise pulses of less than 5 ns (typical) on OE#, CE# or WE# do not initiate a write cycle.

Logical Inhibit

Write cycles are inhibited by holding any one of OE# = V_{IL} , CE# = V_{IH} or WE# = V_{IH} . To initiate a write cycle, CE# and WE# must be a logical zero while OE# is a logical one.

Power-Up Write Inhibit

If WE# = CE# = V_{IL} and OE# = V_{IH} during power up, the device does not accept commands on the rising edge of WE#. The internal state machine is automatically reset to the read mode on power-up.

COMMON FLASH MEMORY INTERFACE (CFI)

The Common Flash Interface (CFI) specification outlines device and host system software interrogation handshake, which allows specific vendor-specified software algorithms to be used for entire families of devices. Software support can then be device-independent, JEDEC ID-independent, and forward- and backward-compatible for the specified flash device families. Flash vendors can standardize their existing interfaces for long-term compatibility.

This device enters the CFI Query mode when the system writes the CFI Query command, 98h, to address 55h, any time the device is ready to read array data. The system can read CFI information at the addresses given in Tables 6–9. To terminate reading CFI data, the system must write the reset command.

The system can also write the CFI query command when the device is in the autoselect mode. The device enters the CFI query mode, and the system can read CFI data at the addresses given in Tables 6–9. The system must write the reset command to return the device to reading array data.

For further information, please refer to the CFI Specification and CFI Publication 100, available via the World Wide Web at <http://www.amd.com/flash/cfi>. Alternatively, contact an AMD representative for copies of these documents.

Table 6. CFI Query Identification String

| Addresses (x16) | Data | Description |
|-------------------|-------------------------|--|
| 10h 11h 12h | 0051h 0052h 0059h | Query Unique ASCII string "QRY" |
| 13h 14h | 0002h 0000h | Primary OEM Command Set |
| 15h 16h | 0040h 0000h | Address for Primary Extended Table |
| 17h 18h | 0000h 0000h | Alternate OEM Command Set (00h = none exists) |
| 19h 1Ah | 0000h 0000h | Address for Alternate OEM Extended Table (00h = none exists) |

Table 7. System Interface String

| Addresses (x16) | Data | Description |
|-----------------|-------|---|
| 1Bh | 0027h | V _{CC} Min. (write/erase) D7–D4: volt, D3–D0: 100 millivolt |
| 1Ch | 0036h | V _{CC} Max. (write/erase) D7–D4: volt, D3–D0: 100 millivolt |
| 1Dh | 0000h | V _{PP} Min. voltage (00h = no V _{PP} pin present) |
| 1Eh | 0000h | V _{PP} Max. voltage (00h = no V _{PP} pin present) |
| 1Fh | 0007h | Typical timeout per single byte/word write 2 ^N μs |
| 20h | 0007h | Typical timeout for Min. size buffer write 2 ^N μs (00h = not supported) |
| 21h | 000Ah | Typical timeout per individual block erase 2 ^N ms |
| 22h | 0000h | Typical timeout for full chip erase 2 ^N ms (00h = not supported) |
| 23h | 0001h | Max. timeout for byte/word write 2 ^N times typical |
| 24h | 0005h | Max. timeout for buffer write 2 ^N times typical |
| 25h | 0004h | Max. timeout per individual block erase 2 ^N times typical |
| 26h | 0000h | Max. timeout for full chip erase 2 ^N times typical (00h = not supported) |

Table 8. Device Geometry Definition

| Addresses (x16) | Data | Description |
|--------------------------|----------------------------------|---|
| 27h | 0017h | Device Size = 2 ^N byte |
| 28h 29h | 0001h 0000h | Flash Device Interface description (refer to CFI publication 100) |
| 2Ah 2Bh | 0005h 0000h | Max. number of byte in multi-byte write = 2 ^N (00h = not supported) |
| 2Ch | 0001h | Number of Erase Block Regions within device (01h = uniform device, 02h = boot device) |
| 2Dh 2Eh 2Fh 30h | 007Fh 0000h 0000h 0001h | Erase Block Region 1 Information (refer to the CFI specification or CFI publication 100) |
| 31h 32h 33h 34h | 0000h 0000h 0000h 0000h | Erase Block Region 2 Information (refer to CFI publication 100) |
| 35h 36h 37h 38h | 0000h 0000h 0000h 0000h | Erase Block Region 3 Information (refer to CFI publication 100) |
| 39h 3Ah 3Bh 3Ch | 0000h 0000h 0000h 0000h | Erase Block Region 4 Information (refer to CFI publication 100) |

Table 9. Primary Vendor-Specific Extended Query

| Addresses (x16) | Data | Description |
|-------------------|-------------------------|---|
| 40h 41h 42h | 0050h 0052h 0049h | Query-unique ASCII string "PRI" |
| 43h | 0031h | Major version number, ASCII |
| 44h | 0033h | Minor version number, ASCII |
| 45h | 0008h | Address Sensitive Unlock (Bits 1-0) 0 = Required, 1 = Not Required Process Technology (Bits 7-2) 0010b = 0.23 μ m MirrorBit |
| 46h | 0002h | Erase Suspend 0 = Not Supported, 1 = To Read Only, 2 = To Read & Write |
| 47h | 0004h | Sector Protect 0 = Not Supported, X = Number of sectors in per group |
| 48h | 0001h | Sector Temporary Unprotect 00 = Not Supported, 01 = Supported |
| 49h | 0004h | Sector Protect/Unprotect scheme 04 = 29LV800 mode |
| 4Ah | 0000h | Simultaneous Operation 00 = Not Supported, X = Number of Sectors in Bank |
| 4Bh | 0000h | Burst Mode Type 00 = Not Supported, 01 = Supported |
| 4Ch | 0001h | Page Mode Type 00 = Not Supported, 01 = 4 Word Page, 02 = 8 Word Page |
| 4Dh | 00B5h | ACC (Acceleration) Supply Minimum 00h = Not Supported, D7-D4: Volt, D3-D0: 100 mV |
| 4Eh | 00C5h | ACC (Acceleration) Supply Maximum 00h = Not Supported, D7-D4: Volt, D3-D0: 100 mV |
| 4Fh | 0004h/ 0005h | Top/Bottom Boot Sector Flag 00h = Uniform Device without WP# protect, 02h = Bottom Boot Device, 03h = Top Boot Device, 04h = Uniform sectors bottom WP# protect, 05h = Uniform sectors top WP# protect |
| 50h | 0001h | Program Suspend 00h = Not Supported, 01h = Supported |

COMMAND DEFINITIONS

Writing specific address and data commands or sequences into the command register initiates device operations. Table 10 defines the valid register command sequences. Writing **incorrect address and data values** or writing them in the **improper sequence** may place the device in an unknown state. A reset command is then required to return the device to reading array data.

All addresses are latched on the falling edge of WE# or CE#, whichever happens later. All data is latched on the rising edge of WE# or CE#, whichever happens

first. Refer to the [AC Characteristics](#) section for timing diagrams.

Reading Array Data

The device is automatically set to reading array data after device power-up. No commands are required to retrieve data. The device is ready to read array data after completing an Embedded Program or Embedded Erase algorithm.

After the device accepts an Erase Suspend command, the device enters the erase-suspend-read mode, after which the system can read data from any

non-erase-suspended sector. After completing a programming operation in the Erase Suspend mode, the system may once again read array data with the same exception. See the [Erase Suspend/Erase Resume Commands](#) section for more information.

The system *must* issue the reset command to return the device to the read (or erase-suspend-read) mode if DQ5 goes high during an active program or erase operation, or if the device is in the autoselect mode. See the next section, [Reset Command](#), for more information.

See also [Requirements for Reading Array Data](#) in the [Device Bus Operations](#) section for more information. The [Read-Only Operations](#) table provides the read parameters, and Figure 14 shows the timing diagram.

Reset Command

Writing the reset command resets the device to the read or erase-suspend-read mode. Address bits are don't cares for this command.

The reset command may be written between the sequence cycles in an erase command sequence before erasing begins. This resets the device to the read mode. Once erasure begins, however, the device ignores reset commands until the operation is complete.

The reset command may be written between the sequence cycles in a program command sequence before programming begins. This resets the device to the read mode. If the program command sequence is written while the device is in the Erase Suspend mode, writing the reset command returns the device to the erase-suspend-read mode. Once programming begins, however, the device ignores reset commands until the operation is complete.

The reset command may be written between the sequence cycles in an autoselect command sequence. Once in the autoselect mode, the reset command must be written to return to the read mode. If the device entered the autoselect mode while in the Erase Suspend mode, writing the reset command returns the device to the erase-suspend-read mode.

If DQ5 goes high during a program or erase operation, writing the reset command returns the device to the read mode (or erase-suspend-read mode if the device was in Erase Suspend).

Note that if DQ1 goes high during a Write Buffer Programming operation, the system must write the Write-to-Buffer-Abort Reset command sequence to reset the device for the next operation.

Autoselect Command Sequence

The autoselect command sequence allows the host system to read several identifier codes at specific addresses:

| Identifier Code | A7:A0 |
|------------------------------|---------|
| Manufacturer ID | 00h |
| Device ID, Cycle 1 | 01h |
| Device ID, Cycle 2 | 0Eh |
| Device ID, Cycle 3 | 0Fh |
| SecSi Sector Factory Protect | 03h |
| Sector Protect Verify | (SA)02h |

Note: The device ID is read over three cycles. SA = Sector Address

Table 10 shows the address and data requirements. This method is an alternative to that shown in Table 3, which is intended for PROM programmers and requires V_{ID} on address pin A9. The autoselect command sequence may be written to an address that is either in the read or erase-suspend-read mode. The autoselect command may not be written while the device is actively programming or erasing.

The autoselect command sequence is initiated by first writing two unlock cycles. This is followed by a third write cycle that contains the autoselect command. The device then enters the autoselect mode. The system may read at any address any number of times without initiating another autoselect command sequence

The system must write the reset command to return to the read mode (or erase-suspend-read mode if the device was previously in Erase Suspend).

Enter SecSi Sector/Exit SecSi Sector Command Sequence

The SecSi Sector region provides a secured data area containing an 8-word random Electronic Serial Number (ESN). The system can access the SecSi Sector region by issuing the three-cycle Enter SecSi Sector command sequence. The device continues to access the SecSi Sector region until the system issues the four-cycle Exit SecSi Sector command sequence. The Exit SecSi Sector command sequence returns the device to normal operation. Table 10 shows the address and data requirements for both command sequences. See also "SecSi (Secured Silicon) Sector Flash Memory Region" for further information. *Note that the ACC function and unlock bypass modes are not available when the SecSi Sector is enabled.*

Word Program Command Sequence

Programming is a four-bus-cycle operation. The program command sequence is initiated by writing two unlock write cycles, followed by the program set-up command. The program address and data are written next, which in turn initiate the Embedded Program algorithm. The system is *not* required to provide further

controls or timings. The device automatically provides internally generated program pulses and verifies the programmed cell margin. Table 10 shows the address and data requirements for the word program command sequence.

When the Embedded Program algorithm is complete, the device then returns to the read mode and addresses are no longer latched. The system can determine the status of the program operation by using DQ7 or DQ6. Refer to the [Write Operation Status](#) section for information on these status bits.

Any commands written to the device during the Embedded Program Algorithm are ignored. Note that a **hardware reset** immediately terminates the program operation. The program command sequence should be reinitiated once the device has returned to the read mode, to ensure data integrity. *Note that the ACC function and unlock bypass modes are not available when the SecSi Sector is enabled.*

Programming is allowed in any sequence and across sector boundaries. **A bit cannot be programmed from “0” back to a “1.”** Attempting to do so may cause the device to set DQ5 = 1, or cause the DQ7 and DQ6 status bits to indicate the operation was successful. However, a succeeding read will show that the data is still “0.” Only erase operations can convert a “0” to a “1.”

Unlock Bypass Command Sequence

The unlock bypass feature allows the system to program words to the device faster than using the standard program command sequence. The unlock bypass command sequence is initiated by first writing two unlock cycles. This is followed by a third write cycle containing the unlock bypass command, 20h. The device then enters the unlock bypass mode. A two-cycle unlock bypass program command sequence is all that is required to program in this mode. The first cycle in this sequence contains the unlock bypass program command, A0h; the second cycle contains the program address and data. Additional data is programmed in the same manner. This mode dispenses with the initial two unlock cycles required in the standard program command sequence, resulting in faster total programming time. Table 10 shows the requirements for the command sequence.

During the unlock bypass mode, only the Unlock Bypass Program and Unlock Bypass Reset commands are valid. To exit the unlock bypass mode, the system must issue the two-cycle unlock bypass reset command sequence. The first cycle must contain the data 90h. The second cycle must contain the data 00h. The device then returns to the read mode.

Write Buffer Programming

Write Buffer Programming allows the system write to a maximum of 16 words in one programming operation. This results in faster effective programming time than the standard programming algorithms. The Write Buffer Programming command sequence is initiated by first writing two unlock cycles. This is followed by a third write cycle containing the Write Buffer Load command written at the Sector Address in which programming will occur. The fourth cycle writes the sector address and the number of word locations, minus one, to be programmed. For example, if the system will program 6 unique address locations, then 05h should be written to the device. This tells the device how many write buffer addresses will be loaded with data and therefore when to expect the Program Buffer to Flash command. The number of locations to program cannot exceed the size of the write buffer or the operation will abort.

The fifth cycle writes the first address location and data to be programmed. The write-buffer-page is selected by address bits $A_{MAX}-A_4$. All subsequent address/data pairs must fall within the selected-write-buffer-page. The system then writes the remaining address/data pairs into the write buffer. Write buffer locations may be loaded in any order.

The write-buffer-page address must be the same for all address/data pairs loaded into the write buffer. (This means Write Buffer Programming cannot be performed across multiple write-buffer pages. This also means that Write Buffer Programming cannot be performed across multiple sectors. If the system attempts to load programming data outside of the selected write-buffer page, the operation will abort.

Note that if a Write Buffer address location is loaded multiple times, the address/data pair counter will be decremented for every data load operation. The host system must therefore account for loading a write-buffer location more than once. The counter decrements for each data load operation, not for each unique write-buffer-address location. Note also that if an address location is loaded more than once into the buffer, the final data loaded for that address will be programmed.

Once the specified number of write buffer locations have been loaded, the system must then write the Program Buffer to Flash command at the sector address. Any other address and data combination aborts the Write Buffer Programming operation. The device then begins programming. Data polling should be used while monitoring the last address location loaded into the write buffer. DQ7, DQ6, DQ5, and DQ1 should be monitored to determine the device status during Write Buffer Programming.

The write-buffer programming operation can be suspended using the standard program suspend/resume commands. Upon successful completion of the Write Buffer Programming operation, the device is ready to execute the next command.

The Write Buffer Programming Sequence can be aborted in the following ways:

- Load a value that is greater than the page buffer size during the Number of Locations to Program step.
- Write to an address in a sector different than the one specified during the Write-Buffer-Load command.
- Write an Address/Data pair to a different write-buffer-page than the one selected by the Starting Address during the write buffer data loading stage of the operation.
- Write data other than the Confirm Command after the specified number of data load cycles.

The abort condition is indicated by DQ1 = 1, DQ7 = DATA# (for the last address location loaded), DQ6 =

toggle, and DQ5=0. A Write-to-Buffer-Abort Reset command sequence must be written to reset the device for the next operation. Note that the full 3-cycle Write-to-Buffer-Abort Reset command sequence is required when using Write-Buffer-Programming features in Unlock Bypass mode.

Accelerated Program

The device offers accelerated program operations through the ACC pin. When the system asserts V_{HH} on the ACC pin, the device automatically enters the Unlock Bypass mode. The system may then write the two-cycle Unlock Bypass program command sequence. The device uses the higher voltage on the ACC pin to accelerate the operation. *Note that the ACC pin must not be at V_{HH} for operations other than accelerated programming, or device damage may result.*

Figure 5 illustrates the algorithm for the program operation. Refer to the [Erase and Program Operations](#) table in the AC Characteristics section for parameters, and Figure 18 for timing diagrams.

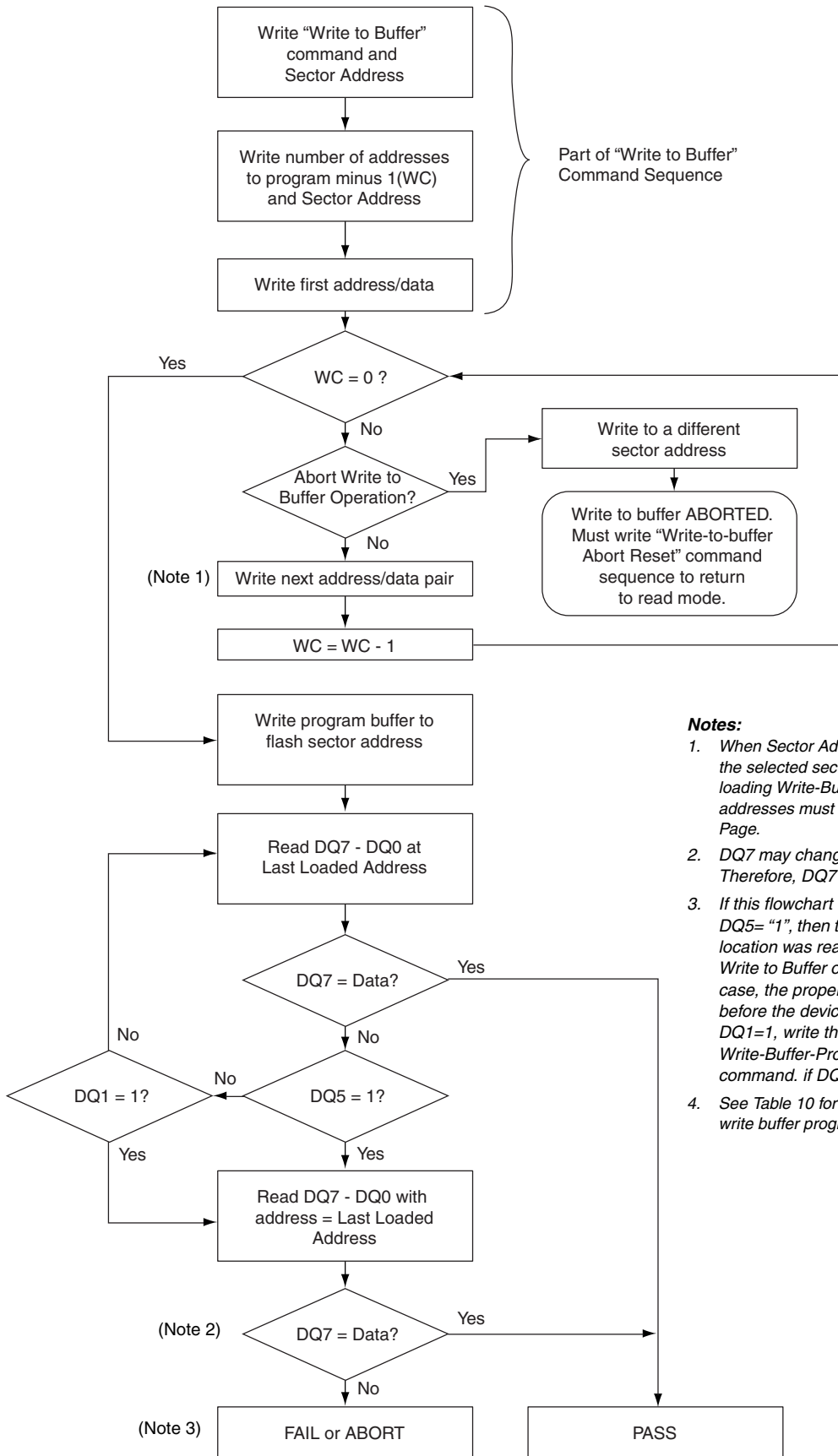

Notes:

1. When Sector Address is specified, any address in the selected sector is acceptable. However, when loading Write-Buffer address locations with data, all addresses must fall within the selected Write-Buffer Page.
2. DQ7 may change simultaneously with DQ5. Therefore, DQ7 should be verified.
3. If this flowchart location was reached because DQ5= "1", then the device FAILED. If this flowchart location was reached because DQ1= "1", then the Write to Buffer operation was ABORTED. In either case, the proper reset command must be written before the device can begin another operation. If DQ1=1, write the Write-Buffer-Programming-Abort-Reset command. If DQ5=1, write the Reset command.
4. See Table 10 for command sequences required for write buffer programming.

Figure 4. Write Buffer Programming Operation

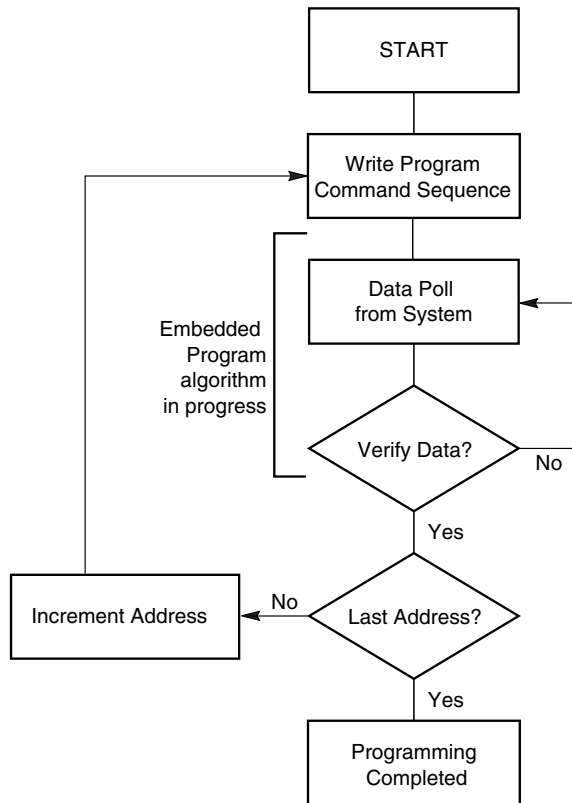

Note: See Table 10 for program command sequence.

Figure 5. Program Operation

Program Suspend/Program Resume Command Sequence

The Program Suspend command allows the system to interrupt a programming operation or a Write to Buffer programming operation so that data can be read from any non-suspended sector. When the Program Suspend command is written during a programming process, the device halts the program operation within 5 μ s typical (maximum of 15 μ s) and updates the status bits. Addresses are not required when writing the Program Suspend command.

After the programming operation has been suspended, the system can read array data from any non-suspended sector. The Program Suspend command may also be issued during a programming operation while an erase is suspended. In this case, data may be read from any addresses not in Erase Suspend or Program Suspend. If a read is needed from the SecSi Sector area (One-time Program area), then user must use the proper command sequences to enter and exit this region. *Note that the SecSi Sector, autoselect, and CFI functions are unavailable when an program operation is in progress.*

The system may also write the autoselect command sequence when the device is in the Program Suspend mode. The system can read as many autoselect codes as required. When the device exits the autoselect mode, the device reverts to the Program Suspend mode, and is ready for another valid operation. See Autoselect Command Sequence for more information.

After the Program Resume command is written, the device reverts to programming. The system can determine the status of the program operation using the DQ7 or DQ6 status bits, just as in the standard program operation. See [Write Operation Status](#) for more information.

The system must write the Program Resume command (address bits are don't care) to exit the Program Suspend mode and continue the programming operation. Further writes of the Resume command are ignored. Another Program Suspend command can be written after the device has resume programming.

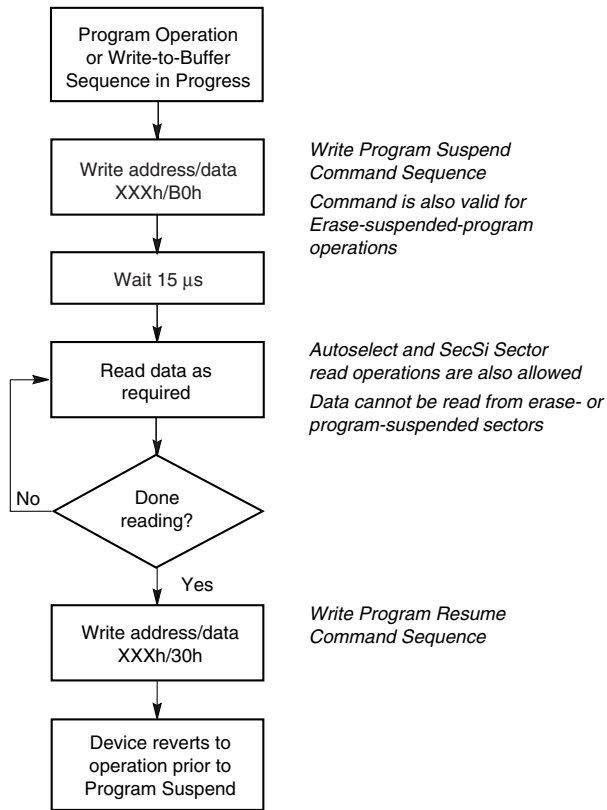

Figure 6. Program Suspend/Program Resume

Chip Erase Command Sequence

Chip erase is a six bus cycle operation. The chip erase command sequence is initiated by writing two unlock cycles, followed by a set-up command. Two additional unlock write cycles are then followed by the chip erase command, which in turn invokes the Embedded Erase algorithm. The device does *not* require the system to preprogram prior to erase. The Embedded Erase algorithm automatically preprograms and verifies the entire memory for an all zero data pattern prior to electrical erase. The system is not required to provide any controls or timings during these operations. Table 10 shows the address and data requirements for the chip erase command sequence.

When the Embedded Erase algorithm is complete, the device returns to the read mode and addresses are no longer latched. The system can determine the status of the erase operation by using DQ7, DQ6, or DQ2. Refer to the [Write Operation Status](#) section for information on these status bits.

Any commands written during the chip erase operation are ignored. However, note that a **hardware reset** immediately terminates the erase operation. If that occurs, the chip erase command sequence should be reinitiated once the device has returned to reading array data, to ensure data integrity. *Note that the SecSi Sector, autoselect, and CFI functions are unavailable when an erase operation is in progress.*

Figure 7 illustrates the algorithm for the erase operation. Refer to the [Erase and Program Operations](#) tables in the AC Characteristics section for parameters, and Figure 20 section for timing diagrams.

Sector Erase Command Sequence

Sector erase is a six bus cycle operation. The sector erase command sequence is initiated by writing two unlock cycles, followed by a set-up command. Two additional unlock cycles are written, and are then followed by the address of the sector to be erased, and the sector erase command. Table 10 shows the address and data requirements for the sector erase command sequence.

The device does *not* require the system to preprogram prior to erase. The Embedded Erase algorithm automatically programs and verifies the entire memory for an all zero data pattern prior to electrical erase. The system is not required to provide any controls or timings during these operations.

After the command sequence is written, a sector erase time-out of 50 μ s occurs. During the time-out period, additional sector addresses and sector erase commands may be written. Loading the sector erase buffer may be done in any sequence, and the number of sectors may be from one sector to all sectors. The time between these additional cycles must be less than 50 μ s, otherwise erasure may begin. Any sector erase address and command following the exceeded time-out may or may not be accepted. It is recommended that processor interrupts be disabled during this time to ensure all commands are accepted. The interrupts can be re-enabled after the last Sector Erase command is written. **Any command other than Sector Erase or Erase Suspend during the time-out period resets the device to the read mode.** The system must re-write the command sequence and any additional addresses and commands. *Note that the SecSi Sector, autoselect, and CFI functions are unavailable when an erase operation is in progress.*

The system can monitor DQ3 to determine if the sector erase timer has timed out (See the section on DQ3: Sector Erase Timer.). The time-out begins from the rising edge of the final WE# pulse in the command sequence.

When the Embedded Erase algorithm is complete, the device returns to reading array data and addresses are no longer latched. The system can determine the status of the erase operation by reading DQ7, DQ6, or DQ2 in the erasing sector. Refer to the [Write Operation Status](#) section for information on these status bits.

Once the sector erase operation has begun, only the Erase Suspend command is valid. All other commands are ignored. However, note that a **hardware reset** immediately terminates the erase operation. If that occurs, the sector erase command sequence should be reinitiated once the device has returned to reading array data, to ensure data integrity.

Figure 7 illustrates the algorithm for the erase operation. Refer to the [Erase and Program Operations](#) tables in the AC Characteristics section for parameters, and Figure 20 section for timing diagrams.

Erase Suspend/Erase Resume Commands

The Erase Suspend command, B0h, allows the system to interrupt a sector erase operation and then read data from, or program data to, any sector not selected for erasure. This command is valid only during the sector erase operation, including the 50 μ s time-out period during the sector erase command sequence. The Erase Suspend command is ignored if written during the chip erase operation or Embedded Program algorithm.

When the Erase Suspend command is written during the sector erase operation, the device requires a typical of 5 μ s (maximum of 20 μ s) to suspend the erase operation. However, when the Erase Suspend command is written during the sector erase time-out, the device immediately terminates the time-out period and suspends the erase operation.

After the erase operation has been suspended, the device enters the erase-suspend-read mode. The system can read data from or program data to any sector not selected for erasure. (The device “erase suspends” all sectors selected for erasure.) Reading at any address within erase-suspended sectors produces status information on DQ7–DQ0. The system can use DQ7, or DQ6 and DQ2 together, to determine if a sector is actively erasing or is erase-suspended. Refer to the [Write Operation Status](#) section for information on these status bits.

After an erase-suspended program operation is complete, the device returns to the erase-suspend-read mode. The system can determine the status of the program operation using the DQ7 or DQ6 status bits, just as in the standard word program operation. Refer to the [Write Operation Status](#) section for more information.

In the erase-suspend-read mode, the system can also issue the autoselect command sequence. Refer to the [Autoselect Mode](#) and [Autoselect Command Sequence](#) sections for details.

To resume the sector erase operation, the system must write the Erase Resume command. Further writes of the Resume command are ignored. Another Erase Suspend command can be written after the chip has resumed erasing.

Note: During an erase operation, this flash device performs multiple internal operations which are invisible to the system. When an erase operation is suspended, any of the internal operations that were not fully completed must be restarted. As such, if this flash device is continually issued suspend/resume commands in rapid succession, erase progress will be impeded as a function of the number of suspends. The result will be a longer cumulative erase time than without suspends. Note that the additional suspends do not affect device reliability or future performance. In most systems rapid erase/suspend activity occurs only briefly. In this example, erase performance will not be significantly impacted.

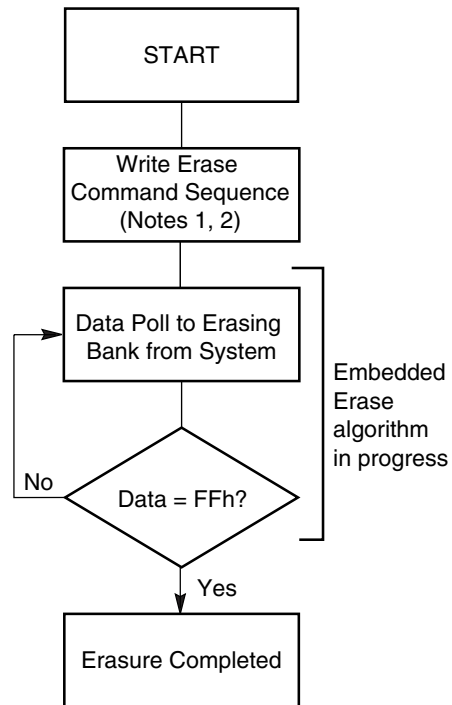
**Notes:**

1. See Table 10 for erase command sequence.
2. See the section on DQ3 for information on the sector erase timer.

Figure 7. Erase Operation

Command Definitions

Table 10. Command Definitions

| Command Sequence (Notes) | | Cycles | Bus Cycles (Notes 1–4) | | | | | | | | | | | |
|---------------------------------------|--|--------|------------------------|------|------|------|------|------|---------|----------|------|------|------|------|
| | | | Addr | Data | Addr | Data | Addr | Data | Addr | Data | Addr | Data | Addr | Data |
| Read (Note 5) | | 1 | RA | RD | | | | | | | | | | |
| Reset (Note 6) | | 1 | XXX | F0 | | | | | | | | | | |
| Autoselect (Note 7) | Manufacturer ID | 4 | 555 | AA | 2AA | 55 | 555 | 90 | X00 | 0001 | | | | |
| | Device ID (Note 8) | 6 | 555 | AA | 2AA | 55 | 555 | 90 | X01 | 227E | X0E | 2213 | X0F | 2201 |
| | SecSi™ Sector Factory Protect (Note 9) | 4 | 555 | AA | 2AA | 55 | 555 | 90 | X03 | (Note 9) | | | | |
| | Sector Group Protect Verify (Note 10) | 4 | 555 | AA | 2AA | 55 | 555 | 90 | (SA)X02 | 00/01 | | | | |
| Enter SecSi Sector Region | | 3 | 555 | AA | 2AA | 55 | 555 | 88 | | | | | | |
| Exit SecSi Sector Region | | 4 | 555 | AA | 2AA | 55 | 555 | 90 | XXX | 00 | | | | |
| Program | | 4 | 555 | AA | 2AA | 55 | 555 | A0 | PA | PD | | | | |
| Write to Buffer (Note 11) | | 6 | 555 | AA | 2AA | 55 | SA | 25 | SA | WC | PA | PD | WBL | PD |
| Program Buffer to Flash | | 1 | SA | 29 | | | | | | | | | | |
| Write to Buffer Abort Reset (Note 12) | | 3 | 555 | AA | 2AA | 55 | 555 | F0 | | | | | | |
| Unlock Bypass | | 3 | 555 | AA | 2AA | 55 | 555 | 20 | | | | | | |
| Unlock Bypass Program (Note 13) | | 2 | XXX | A0 | PA | PD | | | | | | | | |
| Unlock Bypass Reset (Note 14) | | 2 | XXX | 90 | XXX | 00 | | | | | | | | |
| Chip Erase | | 6 | 555 | AA | 2AA | 55 | 555 | 80 | 555 | AA | 2AA | 55 | 555 | 10 |
| Sector Erase | | 6 | 555 | AA | 2AA | 55 | 555 | 80 | 555 | AA | 2AA | 55 | SA | 30 |
| Program/Erase Suspend (Note 15) | | 1 | XXX | B0 | | | | | | | | | | |
| Program/Erase Resume (Note 16) | | 1 | XXX | 30 | | | | | | | | | | |
| CFI Query (Note 17) | | 1 | 55 | 98 | | | | | | | | | | |

Legend:

X = Don't care
 RA = Read Address of the memory location to be read.
 RD = Read Data read from location RA during read operation.
 PA = Program Address. Addresses latch on the falling edge of the WE# or CE# pulse, whichever happens later.
 PD = Program Data for location PA. Data latches on the rising edge of WE# or CE# pulse, whichever happens first.

SA = Sector Address of sector to be verified (in autoselect mode) or erased. Address bits A21–A15 uniquely select any sector.
 WBL = Write Buffer Location. Address must be within the same write buffer page as PA.
 WC = Word Count. Number of write buffer locations to load minus 1.

Notes:

- See Table 1 for description of bus operations.
- All values are in hexadecimal.
- Shaded cells indicate read cycles. All other are write cycles.
- During unlock and command cycles, when lower address bits are 555 or 2AA as shown in table, address bits higher than A11 and data bits higher than DQ7 are don't care.
- No unlock or command cycles required when device is in read mode.
- The Reset command is required to return to the read mode (or to the erase-suspend-read mode if previously in Erase Suspend) when the device is in the autoselect mode, or if DQ5 goes high while the device is providing status information.
- The fourth cycle of the autoselect command sequence is a read cycle. Data bits DQ15–DQ8 are don't care. See the [Autoselect Command Sequence](#) section for more information.
- The device ID must be read in three cycles.
- If WP# protects the highest address sector, the data is 98h for factory locked and 18h for not factory locked. If WP# protects the lowest address sector, the data is 88h for factory locked and 08h for not factor locked.
- The data is 00h for an unprotected sector group and 01h for a protected sector group.
- The total number of cycles in the command sequence is determined by the number of words written to the write buffer. The maximum number of cycles in the command sequence is 21, including "Program Buffer to Flash" command.
- Command sequence resets device for next command after aborted write-to-buffer operation.
- The Unlock Bypass command is required prior to the Unlock Bypass Program command.
- The Unlock Bypass Reset command is required to return to the read mode when the device is in the unlock bypass mode.
- The system may read and program in non-erasing sectors, or enter the autoselect mode, when in the Erase Suspend mode. The Erase Suspend command is valid only during a sector erase operation.
- The Erase Resume command is valid only during the Erase Suspend mode.
- Command is valid when device is ready to read array data or when device is in autoselect mode.

WRITE OPERATION STATUS

The device provides several bits to determine the status of a program or erase operation: DQ2, DQ3, DQ5, DQ6, and DQ7. Table 11 and the following subsections describe the function of these bits. DQ7 and DQ6 each offer a method for determining whether a program or erase operation is complete or in progress.

DQ7: Data# Polling

The Data# Polling bit, DQ7, indicates to the host system whether an Embedded Program or Erase algorithm is in progress or completed, or whether the device is in Erase Suspend. Data# Polling is valid after the rising edge of the final WE# pulse in the command sequence.

During the Embedded Program algorithm, the device outputs on DQ7 the complement of the datum programmed to DQ7. This DQ7 status also applies to programming during Erase Suspend. When the Embedded Program algorithm is complete, the device outputs the datum programmed to DQ7. The system must provide the program address to read valid status information on DQ7. If a program address falls within a protected sector, Data# Polling on DQ7 is active for approximately 1 μ s, then the device returns to the read mode.

During the Embedded Erase algorithm, Data# Polling produces a "0" on DQ7. When the Embedded Erase algorithm is complete, or if the device enters the Erase Suspend mode, Data# Polling produces a "1" on DQ7. The system must provide an address within any of the sectors selected for erasure to read valid status information on DQ7.

After an erase command sequence is written, if all sectors selected for erasing are protected, Data# Polling on DQ7 is active for approximately 100 μ s, then the device returns to the read mode. If not all selected sectors are protected, the Embedded Erase algorithm erases the unprotected sectors, and ignores the selected sectors that are protected. However, if the system reads DQ7 at an address within a protected sector, the status may not be valid.

Just prior to the completion of an Embedded Program or Erase operation, DQ7 may change asynchronously with DQ0–DQ6 while Output Enable (OE#) is asserted low. That is, the device may change from providing status information to valid data on DQ7. Depending on when the system samples the DQ7 output, it may read the status or valid data. Even if the device has completed the program or erase operation and DQ7 has valid data, the data outputs on DQ0–DQ6 may be still

invalid. Valid data on DQ0–DQ7 will appear on successive read cycles.

Table 11 shows the outputs for Data# Polling on DQ7. Figure 8 shows the Data# Polling algorithm. Figure 21 in the [AC Characteristics](#) section shows the Data# Polling timing diagram.

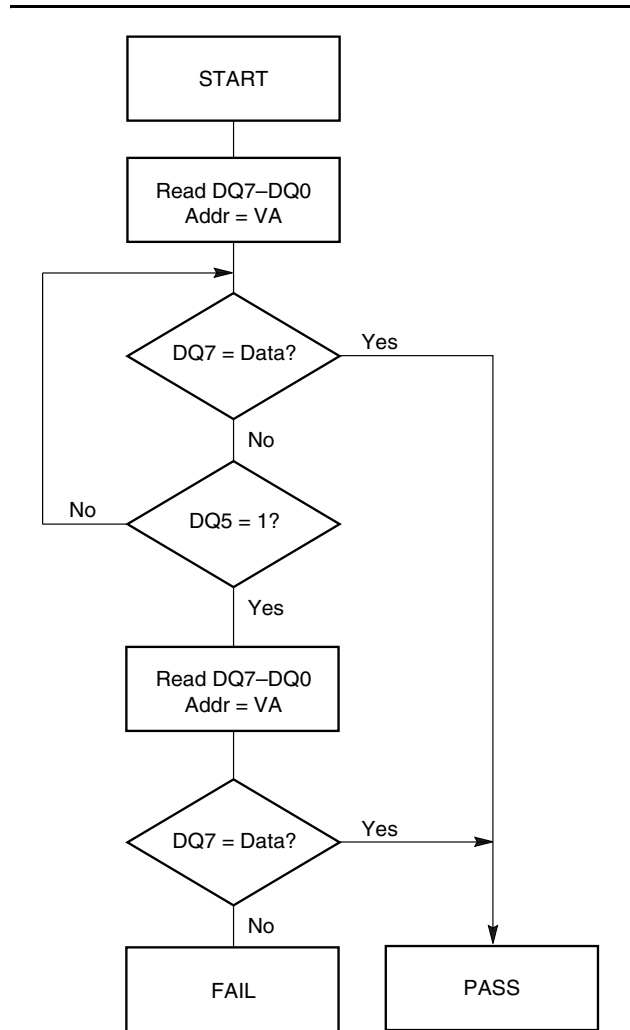

Notes:

1. VA = Valid address for programming. During a sector erase operation, a valid address is any sector address within the sector being erased. During chip erase, a valid address is any non-protected sector address.
2. DQ7 should be rechecked even if DQ5 = "1" because DQ7 may change simultaneously with DQ5.

Figure 8. Data# Polling Algorithm

DQ6: Toggle Bit I

Toggle Bit I on DQ6 indicates whether an Embedded Program or Erase algorithm is in progress or complete, or whether the device has entered the Erase Suspend mode. Toggle Bit I may be read at any address, and is valid after the rising edge of the final WE# pulse in the command sequence (prior to the program or erase operation), and during the sector erase time-out.

During an Embedded Program or Erase algorithm operation, successive read cycles to any address cause DQ6 to toggle. The system may use either OE# or CE# to control the read cycles. When the operation is complete, DQ6 stops toggling.

After an erase command sequence is written, if all sectors selected for erasing are protected, DQ6 toggles for approximately 100 μ s, then returns to reading array data. If not all selected sectors are protected, the Embedded Erase algorithm erases the unprotected sectors, and ignores the selected sectors that are protected.

The system can use DQ6 and DQ2 together to determine whether a sector is actively erasing or is erase-suspended. When the device is actively erasing (that is, the Embedded Erase algorithm is in progress), DQ6 toggles. When the device enters the Erase Suspend mode, DQ6 stops toggling. However, the system must also use DQ2 to determine which sectors are erasing or erase-suspended. Alternatively, the system can use DQ7 (see the subsection on [DQ7: Data# Polling](#)).

If a program address falls within a protected sector, DQ6 toggles for approximately 1 μ s after the program command sequence is written, then returns to reading array data.

DQ6 also toggles during the erase-suspend-program mode, and stops toggling once the Embedded Program algorithm is complete.

Table 11 shows the outputs for Toggle Bit I on DQ6. Figure 9 shows the toggle bit algorithm. Figure 22 in the “AC Characteristics” section shows the toggle bit timing diagrams. Figure 23 shows the differences between DQ2 and DQ6 in graphical form. See also the subsection on [DQ2: Toggle Bit II](#).

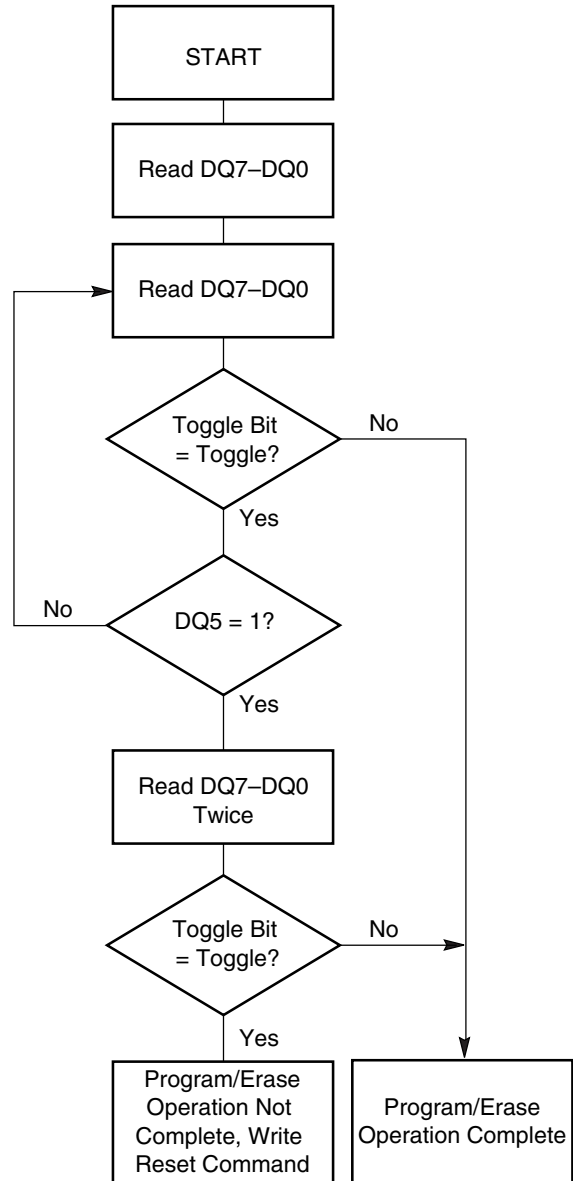

Note: The system should recheck the toggle bit even if DQ5 = “1” because the toggle bit may stop toggling as DQ5 changes to “1.” See the subsections on DQ6 and DQ2 for more information.

Figure 9. Toggle Bit Algorithm

DQ2: Toggle Bit II

The “Toggle Bit II” on DQ2, when used with DQ6, indicates whether a particular sector is actively erasing (that is, the Embedded Erase algorithm is in progress), or whether that sector is erase-suspended. Toggle Bit II is valid after the rising edge of the final WE# pulse in the command sequence.

DQ2 toggles when the system reads at addresses within those sectors that have been selected for erasure. (The system may use either OE# or CE# to control the read cycles.) But DQ2 cannot distinguish whether the sector is actively erasing or is erase-suspended. DQ6, by comparison, indicates whether the device is actively erasing, or is in Erase Suspend, but cannot distinguish which sectors are selected for erasure. Thus, both status bits are required for sector and mode information. Refer to Table 11 to compare outputs for DQ2 and DQ6.

Figure 9 shows the toggle bit algorithm in flowchart form, and the section “DQ2: Toggle Bit II” explains the algorithm. See also the [DQ6: Toggle Bit I](#) subsection. Figure 22 shows the toggle bit timing diagram. Figure 23 shows the differences between DQ2 and DQ6 in graphical form.

Reading Toggle Bits DQ6/DQ2

Refer to Figure 9 for the following discussion. Whenever the system initially begins reading toggle bit status, it must read DQ7–DQ0 at least twice in a row to determine whether a toggle bit is toggling. Typically, the system would note and store the value of the toggle bit after the first read. After the second read, the system would compare the new value of the toggle bit with the first. If the toggle bit is not toggling, the device has completed the program or erase operation. The system can read array data on DQ7–DQ0 on the following read cycle.

However, if after the initial two read cycles, the system determines that the toggle bit is still toggling, the system also should note whether the value of DQ5 is high (see the section on DQ5). If it is, the system should then determine again whether the toggle bit is toggling, since the toggle bit may have stopped toggling just as DQ5 went high. If the toggle bit is no longer toggling, the device has successfully completed the program or erase operation. If it is still toggling, the device did not complete the operation successfully, and the system must write the reset command to return to reading array data.

The remaining scenario is that the system initially determines that the toggle bit is toggling and DQ5 has not gone high. The system may continue to monitor

the toggle bit and DQ5 through successive read cycles, determining the status as described in the previous paragraph. Alternatively, it may choose to perform other system tasks. In this case, the system must start at the beginning of the algorithm when it returns to determine the status of the operation (top of Figure 9).

DQ5: Exceeded Timing Limits

DQ5 indicates whether the program, erase, or write-to-buffer time has exceeded a specified internal pulse count limit. Under these conditions DQ5 produces a “1,” indicating that the program or erase cycle was not successfully completed.

The device may output a “1” on DQ5 if the system tries to program a “1” to a location that was previously programmed to “0.” **Only an erase operation can change a “0” back to a “1.”** Under this condition, the device halts the operation, and when the timing limit has been exceeded, DQ5 produces a “1.”

In all these cases, the system must write the reset command to return the device to the reading the array (or to erase-suspend-read if the device was previously in the erase-suspend-program mode).

DQ3: Sector Erase Timer

After writing a sector erase command sequence, the system may read DQ3 to determine whether or not erasure has begun. (The sector erase timer does not apply to the chip erase command.) If additional sectors are selected for erasure, the entire time-out also applies after each additional sector erase command. When the time-out period is complete, DQ3 switches from a “0” to a “1.” If the time between additional sector erase commands from the system can be assumed to be less than 50 μ s, the system need not monitor DQ3. See also the [Sector Erase Command Sequence](#) section.

After the sector erase command is written, the system should read the status of DQ7 (Data# Polling) or DQ6 (Toggle Bit I) to ensure that the device has accepted the command sequence, and then read DQ3. If DQ3 is “1,” the Embedded Erase algorithm has begun; all further commands (except Erase Suspend) are ignored until the erase operation is complete. If DQ3 is “0,” the device will accept additional sector erase commands. To ensure the command has been accepted, the system software should check the status of DQ3 prior to and following each subsequent sector erase command. If DQ3 is high on the second status check, the last command might not have been accepted.

Table 11 shows the status of DQ3 relative to the other status bits.

DQ1: Write-to-Buffer Abort

DQ1 indicates whether a Write-to-Buffer operation was aborted. Under these conditions DQ1 produces a “1”. The system must issue the

Write-to-Buffer-Abort-Reset command sequence to return the device to reading array data. See [Write Buffer Programming](#) section for more details.

Table 11. Write Operation Status

| Status | | DQ7 (Note 2) | DQ6 | DQ5 (Note 1) | DQ3 | DQ2 (Note 2) | DQ1 |
|----------------------|--|-----------------------|-----------|--------------|-----|--------------|-----|
| Standard Mode | Embedded Program Algorithm | DQ7# | Toggle | 0 | N/A | No toggle | 0 |
| | Embedded Erase Algorithm | 0 | Toggle | 0 | 1 | Toggle | N/A |
| Program Suspend Mode | Program-Suspend Sector | Invalid (not allowed) | | | | | |
| | Non-Program Suspend Sector | Data | | | | | |
| Erase Suspend Mode | Erase-Suspend Sector | 1 | No toggle | 0 | N/A | Toggle | N/A |
| | Non-Erase Suspend Sector | Data | | | | | |
| | Erase-Suspend-Program (Embedded Program) | DQ7# | Toggle | 0 | N/A | N/A | N/A |
| Write-to-Buffer | Busy (Note 3) | DQ7# | Toggle | 0 | N/A | N/A | 0 |
| | Abort (Note 4) | DQ7# | Toggle | 0 | N/A | N/A | 1 |

Notes:

1. DQ5 switches to ‘1’ when an Embedded Program, Embedded Erase, or Write-to-Buffer operation has exceeded the maximum timing limits. Refer to the section on DQ5 for more information.
2. DQ7 and DQ2 require a valid address when reading status information. Refer to the appropriate subsection for further details.
3. The Data# Polling algorithm should be used to monitor the last loaded write-buffer address location.
4. DQ1 switches to ‘1’ when the device has aborted the write-to-buffer operation.

ABSOLUTE MAXIMUM RATINGS

Storage Temperature
 Plastic Packages -65°C to +150°C
 Ambient Temperature
 with Power Applied. -65°C to +125°C
 Voltage with Respect to Ground
 V_{CC} (Note 1) -0.5 V to +4.0 V
 V_{IO} -0.5 V to +4.0 V
 A9, OE#, ACC, and RESET#
 (Note 2). -0.5 V to +12.5 V
 All other pins (Note 1) -0.5 V to V_{CC} +0.5 V
 Output Short Circuit Current (Note 3) 200 mA

Notes:

1. Minimum DC voltage on input or I/O pins is -0.5 V. During voltage transitions, input or I/O pins may overshoot V_{SS} to -2.0 V for periods of up to 20 ns. Maximum DC voltage on input or I/O pins is V_{CC} +0.5 V. See Figure 10. During voltage transitions, input or I/O pins may overshoot to V_{CC} +2.0 V for periods up to 20 ns. See Figure 11.
2. Minimum DC input voltage on pins A9, OE#, ACC, and RESET# is -0.5 V. During voltage transitions, A9, OE#, ACC, and RESET# may overshoot V_{SS} to -2.0 V for periods of up to 20 ns. See Figure 10. Maximum DC input voltage on pin A9, OE#, ACC, and RESET# is +12.5 V which may overshoot to +14.0 V for periods up to 20 ns.
3. No more than one output may be shorted to ground at a time. Duration of the short circuit should not be greater than one second.

Stresses above those listed under "Absolute Maximum Ratings" may cause permanent damage to the device. This is a stress rating only; functional operation of the device at these or any other conditions above those indicated in the operational sections of this data sheet is not implied. Exposure of the device to absolute maximum rating conditions for extended periods may affect device reliability.

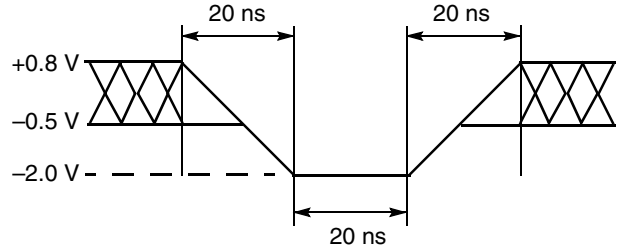

Figure 10. Maximum Negative Overshoot Waveform

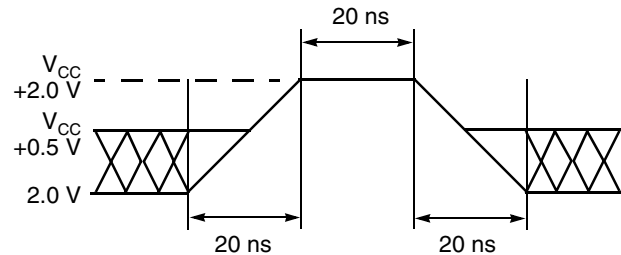

Figure 11. Maximum Positive Overshoot Waveform

OPERATING RANGES

Industrial (I) Devices

Ambient Temperature (T_A) -40°C to +85°C

Supply Voltages

V_{CC} (regulated voltage range) 3.0–3.6 V
 V_{CC} (full voltage range). 2.7–3.6 V
 V_{IO} (Note 2) 1.65–3.6 V

Notes:

1. Operating ranges define those limits between which the functionality of the device is guaranteed.
2. See [Ordering Information](#) section for valid V_{CC}/V_{IO} range combinations. The I/Os will not operate at 3 V when V_{IO} = 1.8 V.

DC CHARACTERISTICS

CMOS Compatible

| Parameter Symbol | Parameter Description (Notes) | Test Conditions | Min | Typ | Max | Unit |
|------------------|---|---|----------------|-----|----------------------|---------|
| I_{LI} | Input Load Current (1) | $V_{IN} = V_{SS}$ to V_{CC} , $V_{CC} = V_{CC\ max}$ | | | ± 1.0 | μA |
| I_{LIT} | A9, ACC Input Load Current | $V_{CC} = V_{CC\ max}$; A9 = 12.5 V | | | 35 | μA |
| I_{LR} | Reset Leakage Current | $V_{CC} = V_{CC\ max}$; RESET# = 12.5 V | | | 35 | μA |
| I_{LO} | Output Leakage Current | $V_{OUT} = V_{SS}$ to V_{CC} , $V_{CC} = V_{CC\ max}$ | | | ± 1.0 | μA |
| I_{CC1} | V_{CC} Active Read Current (2, 3) | CE# = V_{IL} , OE# = V_{IH} , 5 MHz | | 15 | 20 | mA |
| | | CE# = V_{IL} , OE# = V_{IH} , 1 MHz | | 15 | 20 | |
| I_{CC2} | V_{CC} Initial Page Read Current (2, 3) | CE# = V_{IL} , OE# = V_{IH} | | 30 | 50 | mA |
| I_{CC3} | V_{CC} Intra-Page Read Current (2, 3) | CE# = V_{IL} , OE# = V_{IH} | | 10 | 20 | mA |
| I_{CC4} | V_{CC} Active Write Current (3, 4) | CE# = V_{IL} , OE# = V_{IH} | | 50 | 60 | mA |
| I_{CC5} | V_{CC} Standby Current (3) | CE#, RESET# = $V_{CC} \pm 0.3$ V, WP# = V_{IH} | | 1 | 5 | μA |
| I_{CC6} | V_{CC} Reset Current (3) | RESET# = $V_{SS} \pm 0.3$ V, WP# = V_{IH} | | 1 | 5 | μA |
| I_{CC7} | Automatic Sleep Mode (3, 5) | $V_{IH} = V_{CC} \pm 0.3$ V; $V_{IL} = V_{SS} \pm 0.3$ V, WP# = V_{IH} | | 1 | 5 | μA |
| I_{ACC} | ACC Accelerated Program Current (3) | ACC pin | | 10 | 20 | mA |
| | | V_{CC} pin | | 30 | 60 | mA |
| V_{IL1} | Input Low Voltage 1(5, 6) | | -0.5 | | 0.8 | V |
| V_{IH1} | Input High Voltage 1 (5, 6) | | 1.9 | | $V_{CC} + 0.5$ | V |
| V_{IL2} | Input Low Voltage 2 (5, 7) | | -0.5 | | $0.3 \times V_{IO}$ | V |
| V_{IH2} | Input High Voltage 2 (5, 7) | | 1.9 | | $V_{IO} + 0.5$ | V |
| V_{HH} | Voltage for ACC Program Acceleration | $V_{CC} = 2.7 - 3.6$ V | 11.5 | | 12.5 | V |
| V_{ID} | Voltage for Autoselect and Temporary Sector Unprotect | $V_{CC} = 2.7 - 3.6$ V | 11.5 | | 12.5 | V |
| V_{OL} | Output Low Voltage | $I_{OL} = 4.0$ mA, $V_{CC} = V_{CC\ min} = V_{IO}$ | | | $0.15 \times V_{IO}$ | V |
| V_{OH1} | Output High Voltage | $I_{OH} = -2.0$ mA, $V_{CC} = V_{CC\ min} = V_{IO}$ | $0.85 V_{IO}$ | | | V |
| V_{OH2} | | $I_{OH} = -100$ μA , $V_{CC} = V_{CC\ min} = V_{IO}$ | $V_{IO} - 0.4$ | | | V |
| V_{LKO} | Low V_{CC} Lock-Out Voltage (8) | | 2.3 | | 2.5 | V |

Notes:

1. On the WP#/ACC pin only, the maximum input load current when WP# = V_{IL} is ± 5.0 μA .
2. The I_{CC} current listed is typically less than 2 mA/MHz, with OE# at V_{IH} .
3. Maximum I_{CC} specifications are tested with $V_{CC} = V_{CC\ max}$.
4. I_{CC} active while Embedded Erase or Embedded Program is in progress.
5. Automatic sleep mode enables the low power mode when addresses remain stable for $t_{ACC} + 30$ ns. If $V_{IO} < V_{CC}$, maximum V_{IL} for CE# and DQ I/Os is $0.3 V_{IO}$. If $V_{IO} < V_{CC}$, minimum V_{IH} for CE# and DQ I/Os is $0.7 V_{IO}$. Maximum V_{IH} for these connections is $V_{IO} + 0.3$ V
6. V_{CC} voltage requirements.
7. V_{IO} voltage requirements.
8. Not 100% tested.
9. Includes RY/BY#

TEST CONDITIONS

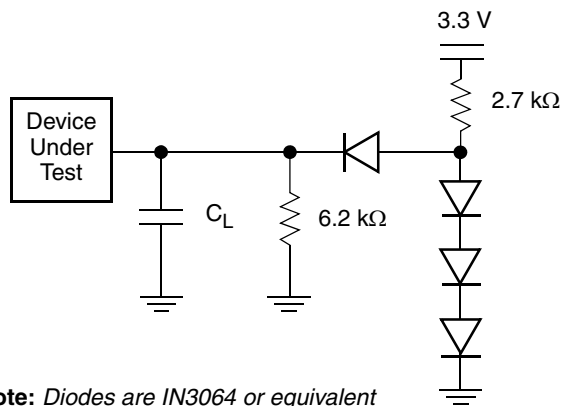

Note: Diodes are IN3064 or equivalent

Figure 12. Test Setup

Table 12. Test Specifications

| Test Condition | All Speeds | Unit |
|--|--------------|------|
| Output Load | 1 TTL gate | |
| Output Load Capacitance, C_L (including jig capacitance) | 30 | pF |
| Input Rise and Fall Times | 5 | ns |
| Input Pulse Levels | 0.0–3.0 | V |
| Input timing measurement reference levels (See Note) | 1.5 | V |
| Output timing measurement reference levels | $0.5 V_{IO}$ | V |

Note: If $V_{IO} < V_{CC}$, the reference level is $0.5 V_{IO}$.

KEY TO SWITCHING WAVEFORMS

| WAVEFORM | INPUTS | OUTPUTS |
|----------|----------------------------------|--|
| | | Steady |
| | | Changing from H to L |
| | | Changing from L to H |
| | Don't Care, Any Change Permitted | Changing, State Unknown |
| | Does Not Apply | Center Line is High Impedance State (High Z) |

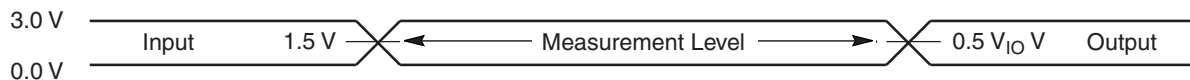

Note: If $V_{IO} < V_{CC}$, the input measurement reference level is $0.5 V_{IO}$.

Figure 13. Input Waveforms and Measurement Levels

AC CHARACTERISTICS

Read-Only Operations

| Parameter | | Description | Test Setup | Unit | Speed Options | | | | | | |
|------------|------------|---|--------------------------|------|---------------|-----------|------|-----|------|-----|----|
| JEDEC C | Std. | | | | 90R | 101R, 101 | 112R | 112 | 120R | 120 | |
| t_{AVAV} | t_{RC} | Read Cycle Time (Note 1) | | Min | 90 | 100 | 110 | 120 | ns | | |
| t_{AVQV} | t_{ACC} | Address to Output Delay | CE#, OE# = V_{IL} | Max | 90 | 100 | 110 | 120 | ns | | |
| t_{ELQV} | t_{CE} | Chip Enable to Output Delay | OE# = V_{IL} | Max | 90 | 100 | 110 | 120 | ns | | |
| | t_{PACC} | Page Access Time | | Max | 25 | 30 | 30 | 40 | 30 | 40 | ns |
| t_{GLQV} | t_{OE} | Output Enable to Output Delay | | Max | 25 | 30 | 30 | 40 | 30 | 40 | ns |
| t_{EHQZ} | t_{DF} | Chip Enable to Output High Z (Note 1) | | Max | 16 | | | | ns | | |
| t_{GHQZ} | t_{DF} | Output Enable to Output High Z (Note 1) | | Max | 16 | | | | ns | | |
| t_{AXQX} | t_{OH} | Output Hold Time From Addresses, CE# or OE#, Whichever Occurs First | | Min | 0 | | | | ns | | |
| | t_{OEh} | Output Enable Hold Time (Note 1) | Read | Min | 0 | | | | ns | | |
| | | | Toggle and Data# Polling | Min | 10 | | | | ns | | |

Notes:

1. Not 100% tested.
2. See Figure 12 and Table 12 for test specifications.
3. AC Specifications listed are tested with $V_{IO} = V_{CC}$. Contact AMD for information on AC operation with $V_{IO} \neq V_{CC}$.

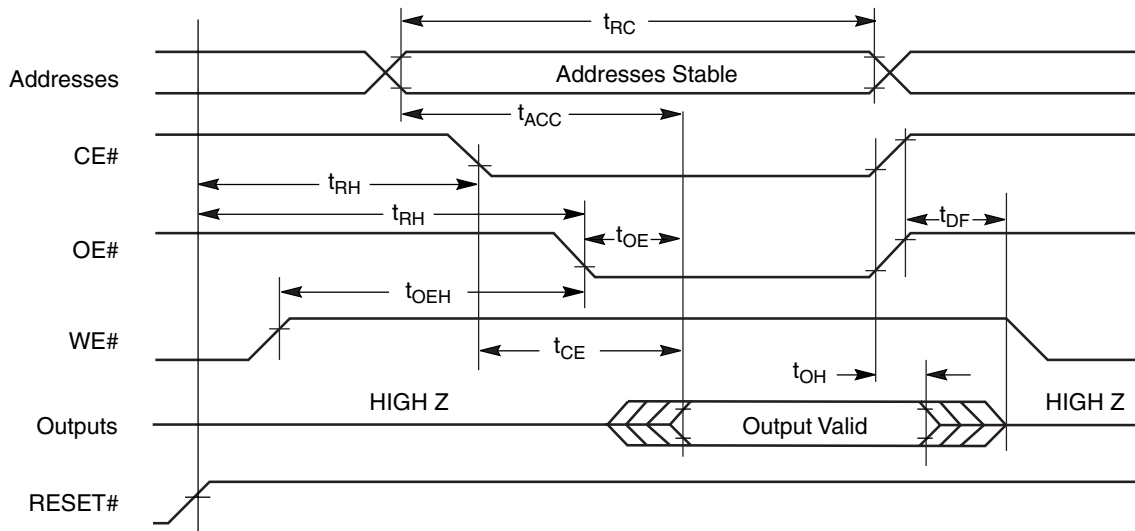

Figure 14. Read Operation Timings

AC CHARACTERISTICS

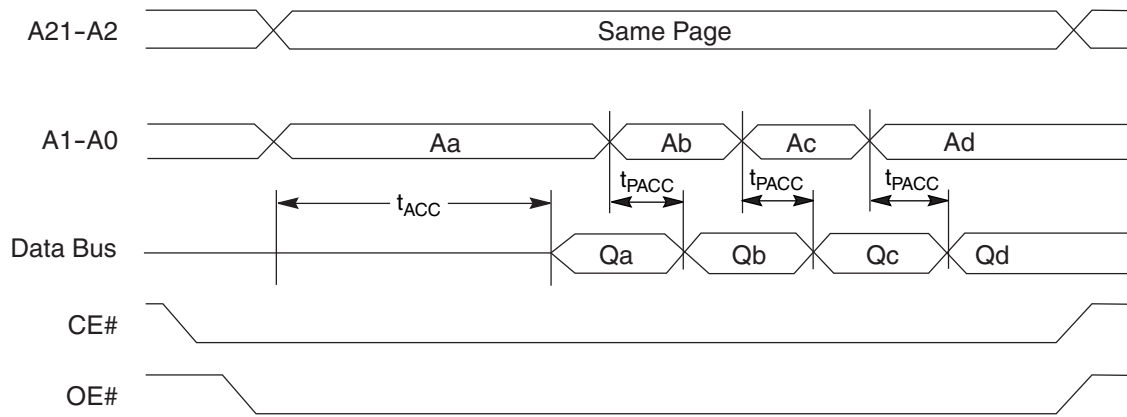

Figure 15. Page Read Timings

AC CHARACTERISTICS

Hardware Reset (RESET#)

| Parameter | | Description | | All Speed Options | Unit |
|-----------|-------------|---|-----|-------------------|---------|
| JEDEC | Std. | | | | |
| | t_{Ready} | RESET# Pin Low (During Embedded Algorithms) to Read Mode (See Note) | Max | 20 | μs |
| | t_{Ready} | RESET# Pin Low (NOT During Embedded Algorithms) to Read Mode (See Note) | Max | 500 | ns |
| | t_{RP} | RESET# Pulse Width | Min | 500 | ns |
| | t_{RH} | Reset High Time Before Read (See Note) | Min | 50 | ns |
| | t_{RPD} | RESET# Low to Standby Mode | Min | 20 | μs |

Notes:

1. Not 100% tested.
2. AC Specifications listed are tested with $V_{IO} = V_{CC}$. Contact AMD for information on AC operation with $V_{IO} \neq V_{CC}$.

AC Characteristics

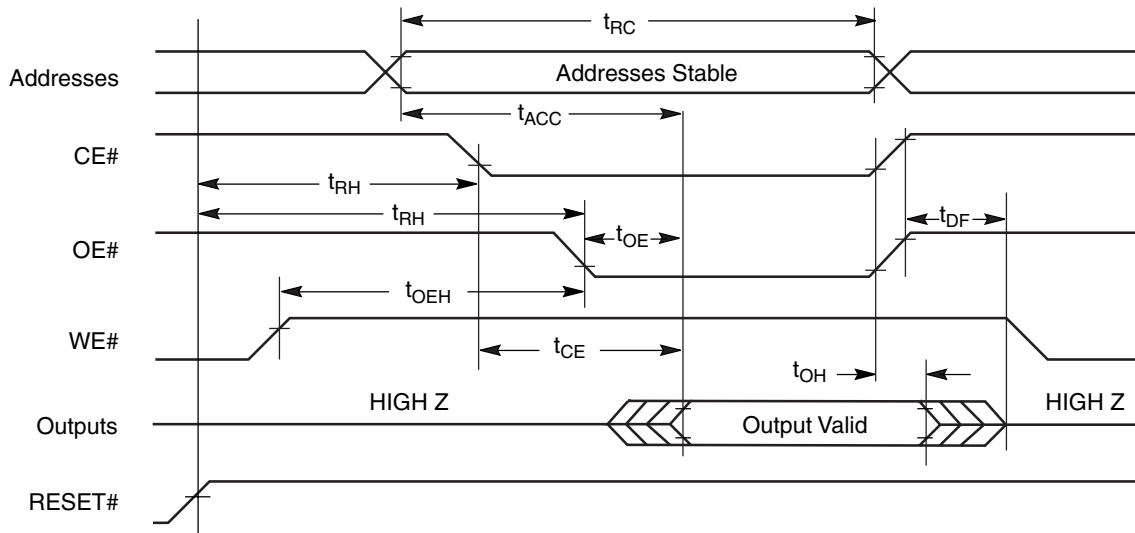

Figure 16. Read Operation Timings

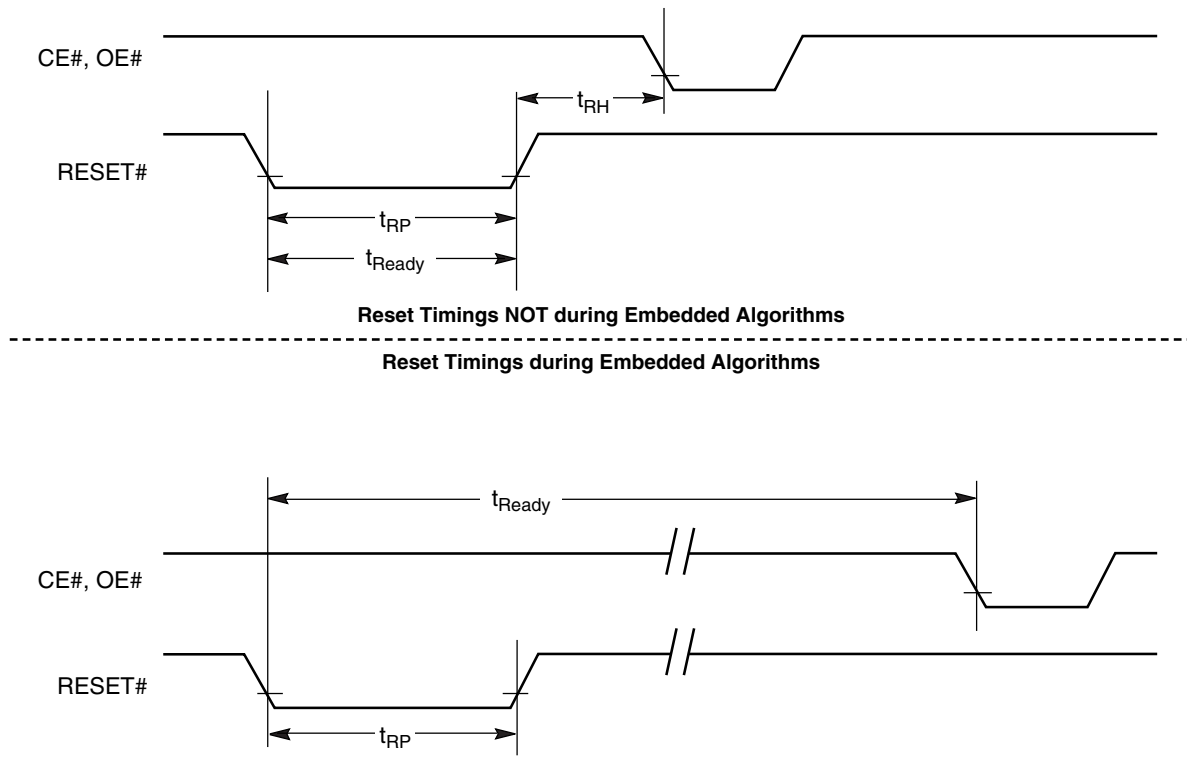

Figure 17. Reset Timings

AC CHARACTERISTICS

Erase and Program Operations

| Parameter | | Description | | Speed Options | | | | Unit |
|-------------|-------------|--|-----|---------------|-----|-----|-----|---------|
| JEDEC | Std. | | | 90R | 101 | 112 | 120 | |
| t_{AVAV} | t_{WC} | Write Cycle Time (Note 1) | Min | 90 | 100 | 110 | 120 | ns |
| t_{AVWL} | t_{AS} | Address Setup Time | Min | 0 | | | | ns |
| | t_{ASO} | Address Setup Time to OE# low during toggle bit polling | Min | 15 | | | | ns |
| t_{WLAX} | t_{AH} | Address Hold Time | Min | 45 | | | | ns |
| | t_{AHT} | Address Hold Time From CE# or OE# high during toggle bit polling | Min | 0 | | | | ns |
| t_{DVWH} | t_{DS} | Data Setup Time | Min | 45 | | | | ns |
| t_{WHDX} | t_{DH} | Data Hold Time | Min | 0 | | | | ns |
| | t_{OEPH} | Output Enable High during toggle bit polling | Min | 20 | | | | ns |
| t_{GHWL} | t_{GHWL} | Read Recovery Time Before Write (OE# High to WE# Low) | Min | 0 | | | | ns |
| t_{ELWL} | t_{CS} | CE# Setup Time | Min | 0 | | | | ns |
| t_{WHEH} | t_{CH} | CE# Hold Time | Min | 0 | | | | ns |
| t_{WLWH} | t_{WP} | Write Pulse Width | Min | 35 | | | | ns |
| t_{WHDL} | t_{WPH} | Write Pulse Width High | Min | 30 | | | | ns |
| t_{WHWH1} | t_{WHWH1} | Write Buffer Program Operation (Notes 2, 3) | Typ | 352 | | | | μ s |
| | | Effective Word Program Time, using the Write Buffer (Notes 2, 4) | Typ | 22 | | | | μ s |
| | | Effective Accelerated Word Program Time, using the Write Buffer (Notes 2, 4) | Typ | 17.6 | | | | μ s |
| | | Single Word Program Operation (Note 2, 5) | Typ | 100 | | | | μ s |
| | | Accelerated Single Word Programming Operation (Note 2, 5) | Typ | 90 | | | | μ s |
| t_{WHWH2} | t_{WHWH2} | Sector Erase Operation (Note 2) | Typ | 0.5 | | | | sec |
| | t_{VHH} | V_{HH} Rise and Fall Time (Note 1) | Min | 250 | | | | ns |
| | t_{VCS} | V_{CC} Setup Time (Note 1) | Min | 50 | | | | μ s |
| | t_{POLL} | Program Valid Before Status Polling (Note 7) | Max | 4 | | | | μ s |

Notes:

1. Not 100% tested.
2. See the "Erase And Programming Performance" section for more information.
3. For 1–16 words programmed.
4. Effective write buffer specification is based upon a 16-word write buffer operation.
5. Word programming specification is based upon a single word programming operation not utilizing the write buffer.
6. AC Specifications listed are tested with $V_{IO} = V_{CC}$. Contact AMD for information on AC operation with $V_{IO} \neq V_{CC}$.
7. When using the program suspend/resume feature, if the suspend command is issued within t_{POLL} , t_{POLL} must be fully re-applied upon resuming the programming operation. If the suspend command is issued after t_{POLL} , t_{POLL} is not required again prior to reading the status bits upon resuming.

AC CHARACTERISTICS

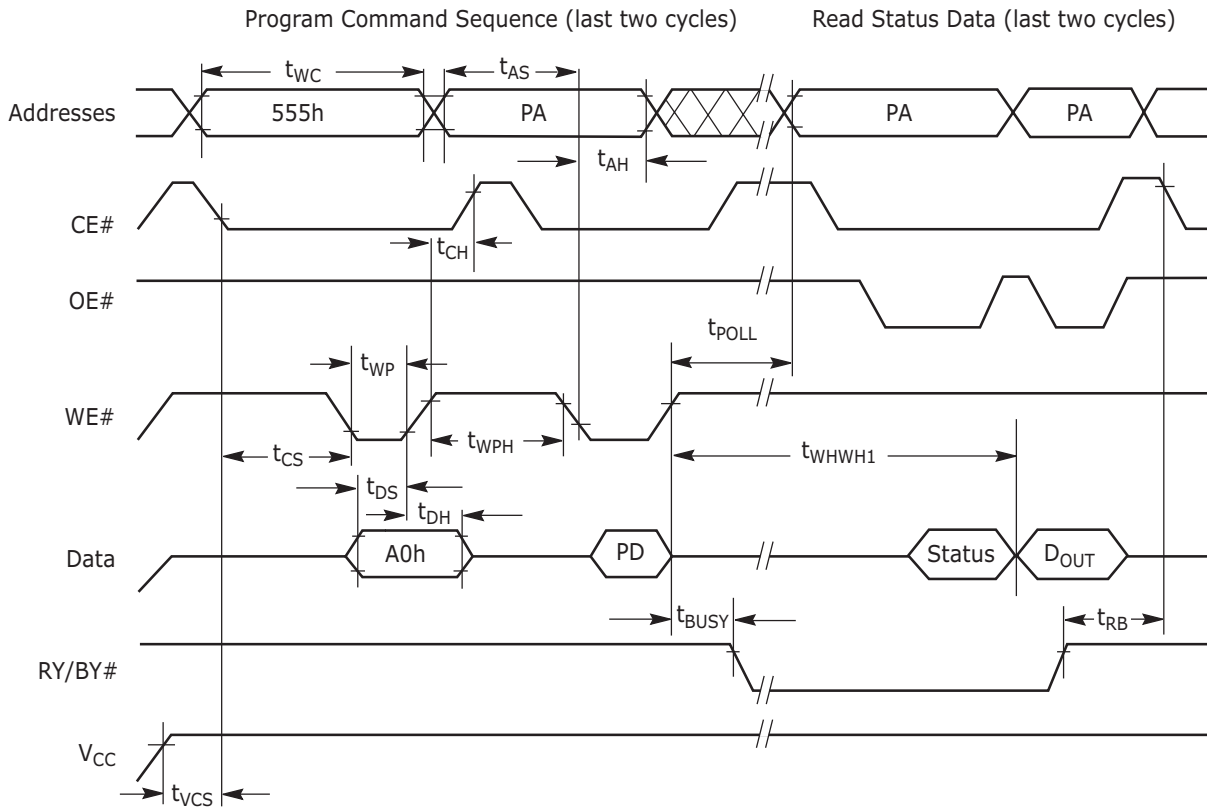

Notes:

1. PA = program address, PD = program data, D_{OUT} is the true data at the program address.
2. Illustration shows device in word mode.

Figure 18. Program Operation Timings

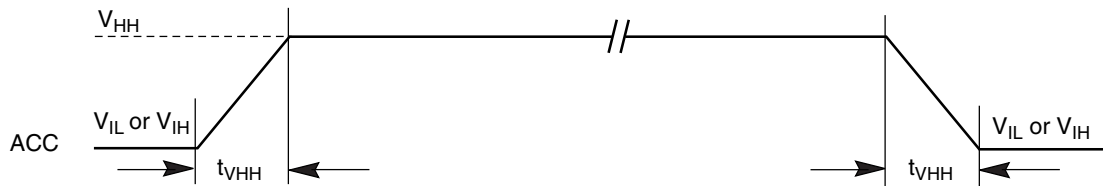
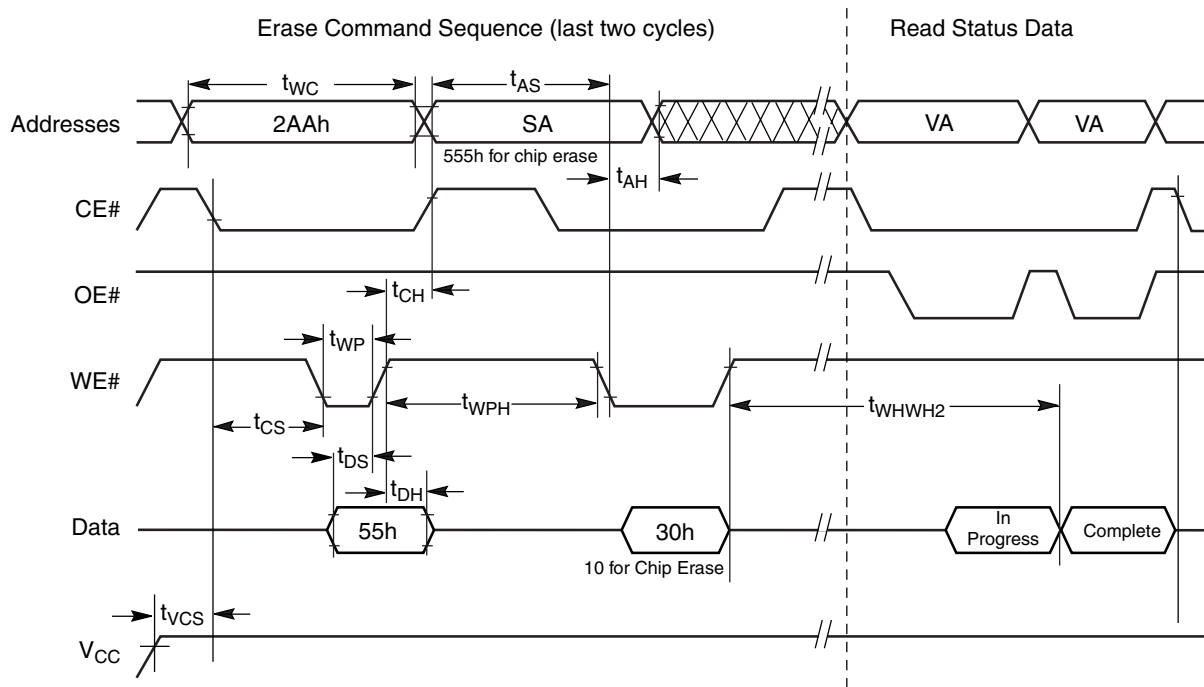

Figure 19. Accelerated Program Timing Diagram

AC CHARACTERISTICS



Notes:

1. SA = sector address (for Sector Erase), VA = Valid Address for reading status data (see "Write Operation Status").
2. These waveforms are for the word mode.

Figure 20. Chip/Sector Erase Operation Timings

AC CHARACTERISTICS

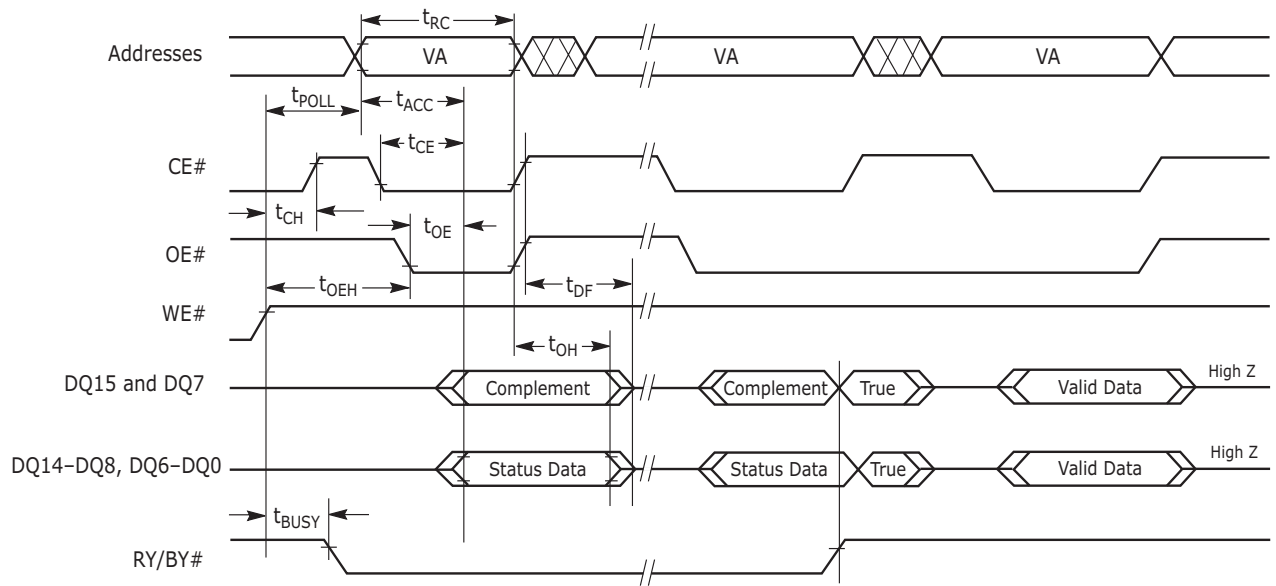

Note: VA = Valid address. Illustration shows first status cycle after command sequence, last status read cycle, and array data read cycle.

Figure 21. Data# Polling Timings (During Embedded Algorithms)

AC CHARACTERISTICS

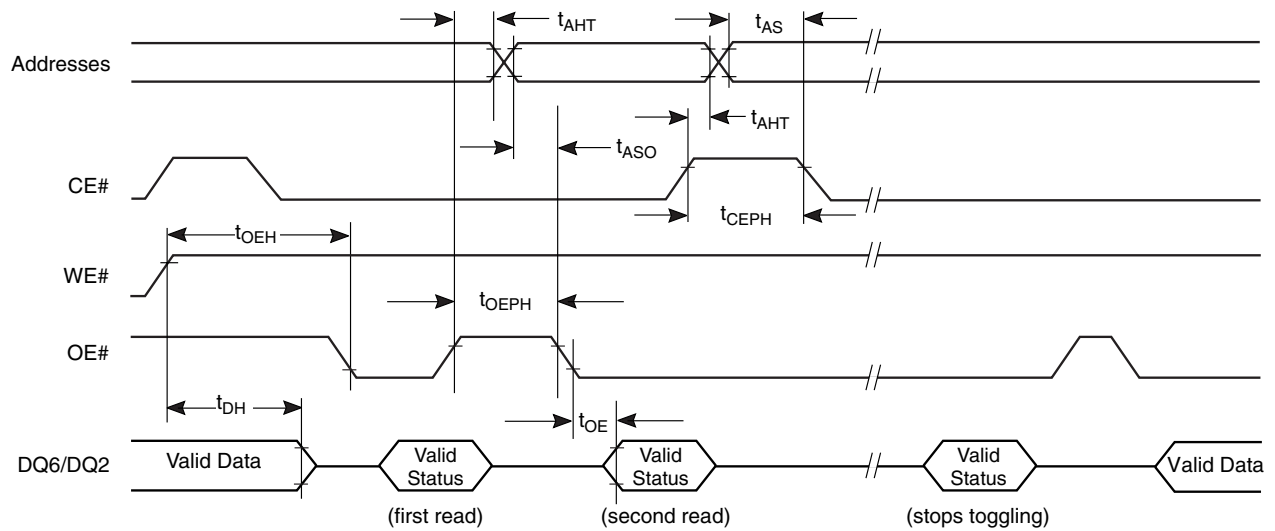

Note: VA = Valid address; not required for DQ6. Illustration shows first two status cycle after command sequence, last status read cycle, and array data read cycle

Figure 22. Toggle Bit Timings (During Embedded Algorithms)

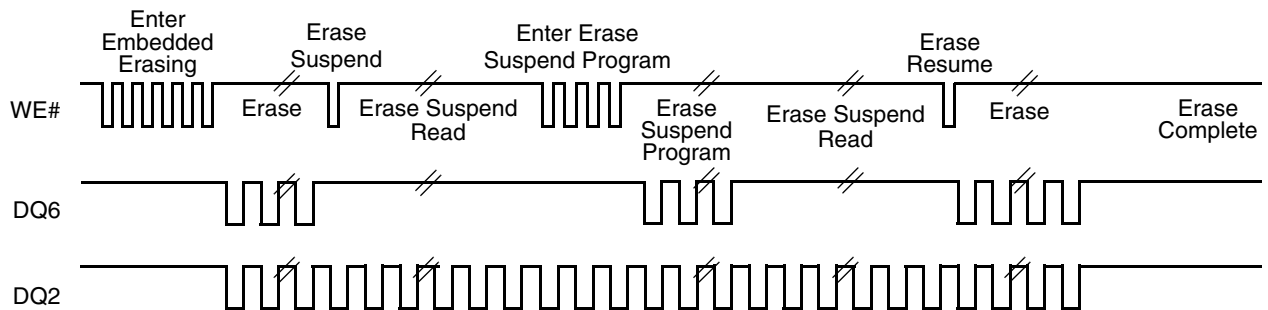

Note: DQ2 toggles only when read at an address within an erase-suspended sector. The system may use OE# or CE# to toggle DQ2 and DQ6.

Figure 23. DQ2 vs. DQ6

AC CHARACTERISTICS

Temporary Sector Unprotect

| Parameter | | Description | | All Speed Options | Unit |
|-----------|------------|--|-----|-------------------|---------|
| JEDEC | Std | | | | |
| | t_{VIDR} | V_{ID} Rise and Fall Time (See Note) | Min | 500 | ns |
| | t_{RSP} | RESET# Setup Time for Temporary Sector Unprotect | Min | 4 | μ s |

Notes:

1. Not 100% tested.
2. AC Specifications listed are tested with $V_{IO} = V_{CC}$. Contact AMD for information on AC operation with $V_{IO} \neq V_{CC}$.

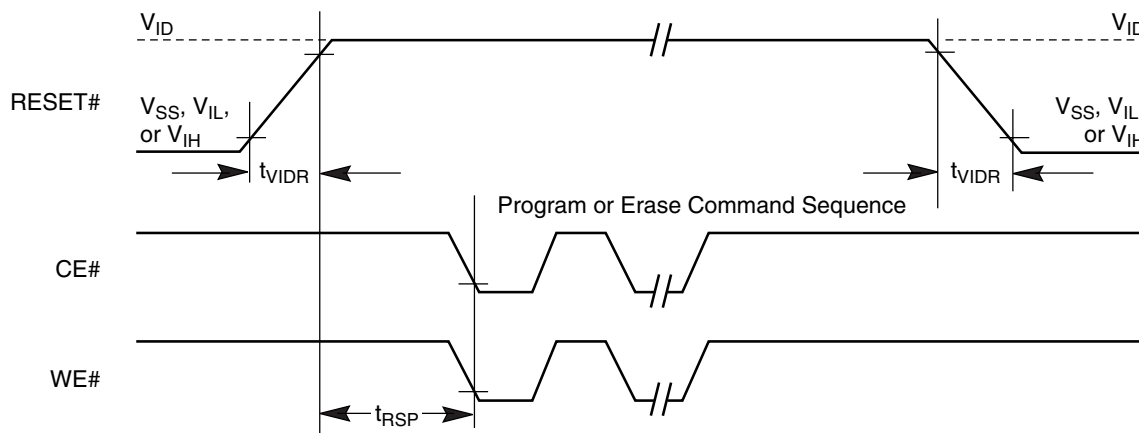
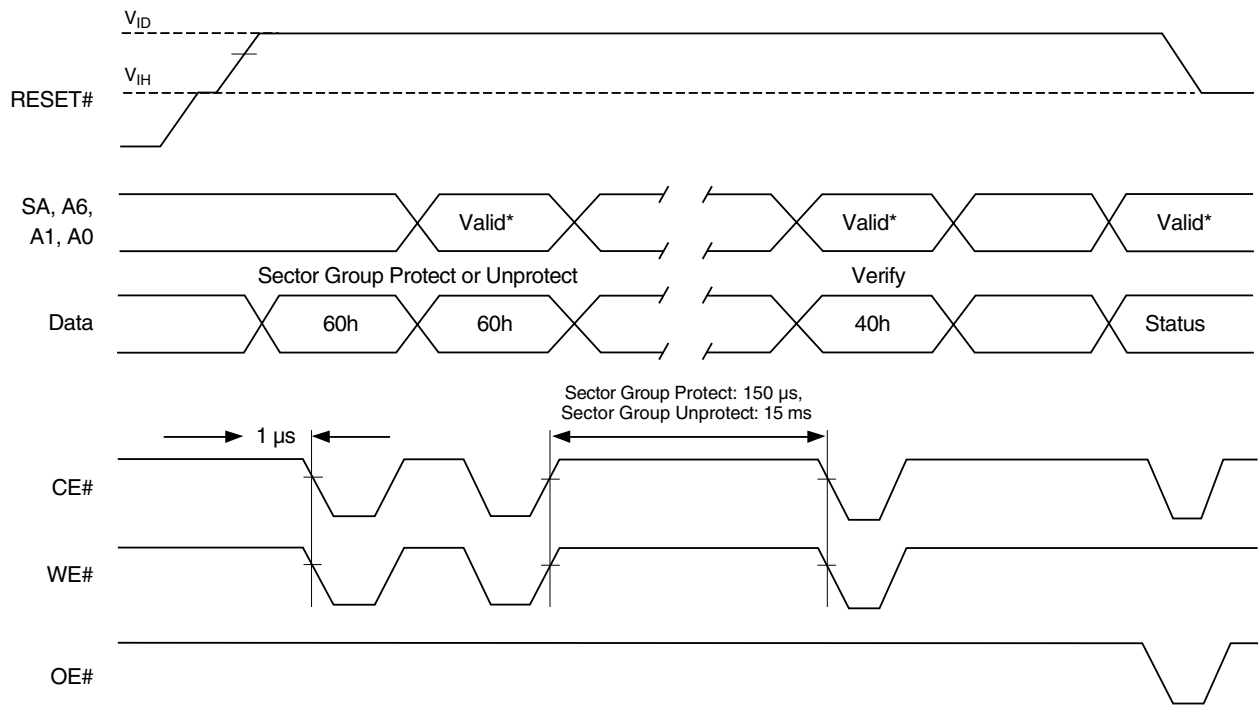

Figure 24. Temporary Sector Group Unprotect Timing Diagram

AC CHARACTERISTICS



* For sector group protect, A6:A0 = 0xx0010. For sector group unprotect, A6:A0 = 1xx0010.

Figure 25. Sector Group Protect and Unprotect Timing Diagram

AC CHARACTERISTICS

Alternate CE# Controlled Erase and Program Operations

| Parameter | | Description | | Speed Options | | | | Unit |
|-------------|-------------|--|-----|---------------|-----------|-----------|-----------|---------|
| JEDEC | Std. | | | 90R | 101, 101R | 112, 112R | 120, 120R | |
| t_{AVAV} | t_{WC} | Write Cycle Time (Note 1) | Min | 90 | 100 | 110 | 120 | ns |
| t_{AVWL} | t_{AS} | Address Setup Time | Min | 0 | | | | ns |
| t_{ELAX} | t_{AH} | Address Hold Time | Min | 45 | | | | ns |
| t_{DVEH} | t_{DS} | Data Setup Time | Min | 45 | | | | ns |
| t_{EHDX} | t_{DH} | Data Hold Time | Min | 0 | | | | ns |
| t_{GHLEL} | t_{GHLEL} | Read Recovery Time Before Write (OE# High to WE# Low) | Min | 0 | | | | ns |
| t_{WLEL} | t_{WS} | WE# Setup Time | Min | 0 | | | | ns |
| t_{EHWH} | t_{WH} | WE# Hold Time | Min | 0 | | | | ns |
| t_{ELEH} | t_{CP} | CE# Pulse Width | Min | 45 | | | | ns |
| t_{EHEL} | t_{CPH} | CE# Pulse Width High | Min | 30 | | | | ns |
| t_{WHWH1} | t_{WHWH1} | Write Buffer Program Operation (Notes 2, 3) | Typ | 352 | | | | μ s |
| | | Effective Word Program Time, using the Write Buffer (Notes 2, 4) | Typ | 22 | | | | μ s |
| | | Effective Accelerated Word Program Time, using the Write Buffer (Notes 2, 4) | Typ | 17.6 | | | | μ s |
| | | Single Word Program Operation (Note 2, 5) | Typ | 100 | | | | μ s |
| | | Accelerated Single Word Programming Operation (Note 2, 5) | Typ | 90 | | | | μ s |
| t_{WHWH2} | t_{WHWH2} | Sector Erase Operation (Note 2) | Typ | 0.5 | | | | sec |
| | t_{RH} | Reset High Time Before Write (Note 1) | Min | 50 | | | | ns |
| | t_{POLL} | Program Valid Before Status Polling (Note 7) | Max | 4 | | | | μ s |

Notes:

1. Not 100% tested.
2. See the "Erase And Programming Performance" section for more information.
3. For 1–16 words programmed.
4. Effective write buffer specification is based upon a 16-word write buffer operation.
5. Word programming specification is based upon a single word programming operation not utilizing the write buffer.
6. AC Specifications listed are tested with $V_{IO} = V_{CC}$. Contact AMD for information on AC operation with $V_{IO} \neq V_{CC}$.
7. When using the program suspend/resume feature, if the suspend command is issued within t_{POLL} , t_{POLL} must be fully re-applied upon resuming the programming operation. If the suspend command is issued after t_{POLL} , t_{POLL} is not required again prior to reading the status bits upon resuming.

AC CHARACTERISTICS

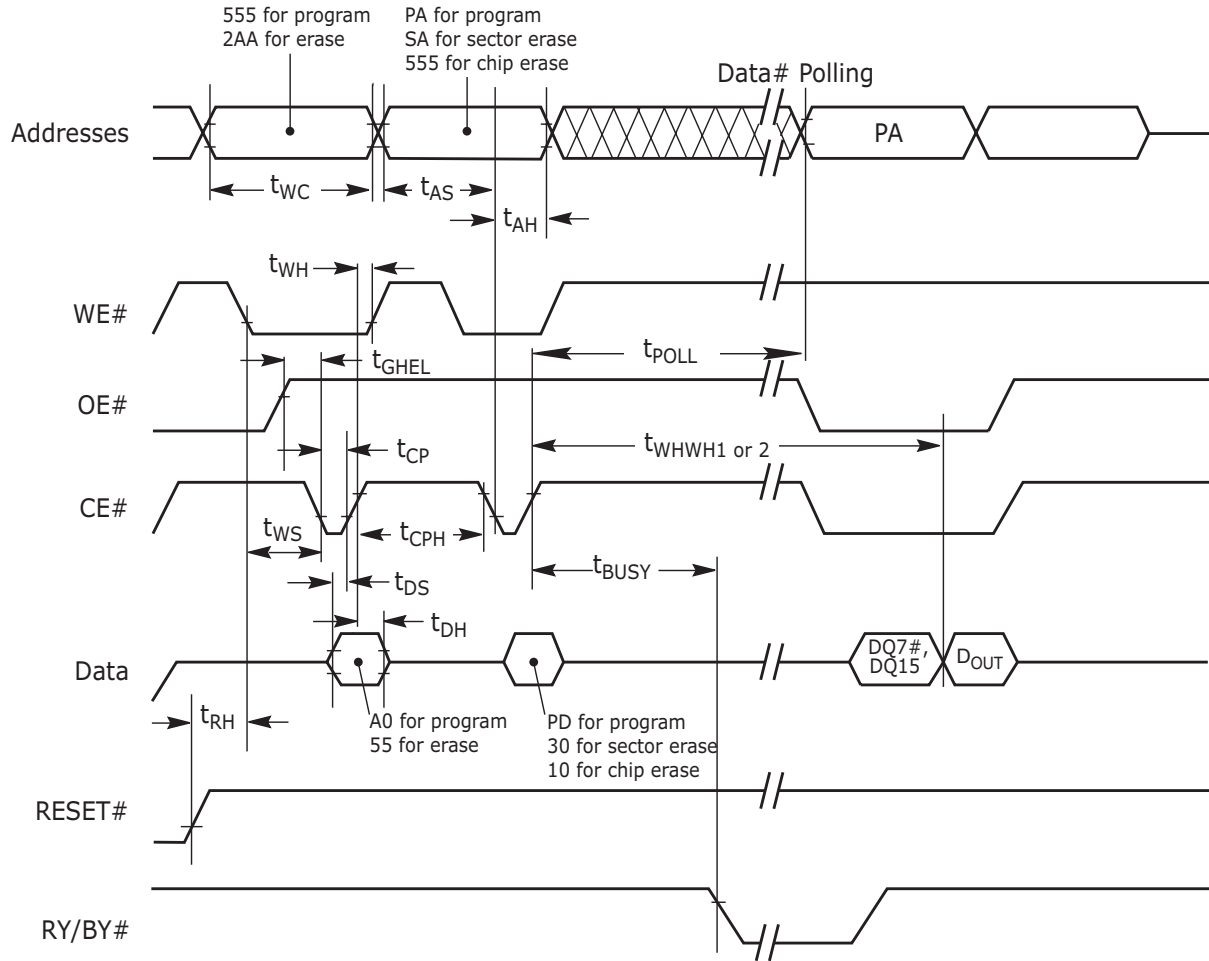

Notes:

1. Figure indicates last two bus cycles of a program or erase operation.
2. PA = program address, SA = sector address, PD = program data.
3. DQ7# is the complement of the data written to the device. D_{OUT} is the data written to the device.
4. Waveforms are for the word mode.

Figure 26. Alternate CE# Controlled Write (Erase/Program) Operation Timings

ERASE AND PROGRAMMING PERFORMANCE

| Parameter | Typ (Note 1) | Max (Note 2) | Unit | Comments |
|--|--------------|--------------|---------|--|
| Sector Erase Time | 0.5 | 15 | sec | Excludes 00h programming prior to erasure (Note 6) |
| Chip Erase Time | 64 | 128 | sec | |
| Single Word Program Time (Note 3) | 100 | 800 | μ s | Excludes system level overhead (Note 7) |
| Accelerated Single Word Program Time (Note 3) | 90 | 720 | μ s | |
| Total Write Buffer Program Time (Note 4) | 352 | 1800 | μ s | |
| Effective Word Program Time, using the Write Buffer (Note 5) | 22 | 113 | μ s | |
| Total Accelerated Write Buffer Program Time (Note 4) | 282 | 1560 | μ s | |
| Effective Accelerated Word Program Time, using the Write Buffer (Note 4) | 17.6 | 98 | μ s | |

1. Typical program and erase times assume the following conditions: 25°C, 3.0 V V_{CC} . Programming specifications assume that all bits are programmed to 00h.
2. Maximum values are measured at $V_{CC} = 3.0$ V, worst case temperature. Maximum values are valid up to and including 100,000 program/erase cycles.
3. Word programming specification is based upon a single word/byte programming operation not utilizing the write buffer.
4. For 1-16 words programmed in a single write buffer programming operation.
5. Effective write buffer specification is calculated on a per-word basis for a 16-word write buffer operation.
6. In the pre-programming step of the Embedded Erase algorithm, all bits are programmed to 00h before erasure.
7. System-level overhead is the time required to execute the command sequence(s) for the program command. See Table 10 for further information on command definitions.
8. The device has a minimum erase and program cycle endurance of 100,000 cycles.

LATCHUP CHARACTERISTICS

| Description | Min | Max |
|--|---------|------------------|
| Input voltage with respect to V_{SS} on all pins except I/O pins (including A9, OE#, and RESET#) | -1.0 V | 12.5 V |
| Input voltage with respect to V_{SS} on all I/O pins | -1.0 V | $V_{CC} + 1.0$ V |
| V_{CC} Current | -100 mA | +100 mA |

Note: Includes all pins except V_{CC} . Test conditions: $V_{CC} = 3.0$ V, one pin at a time.

TSOP PIN CAPACITANCE

| Parameter Symbol | Parameter Description | Test Setup | Typ | Max | Unit |
|------------------|-------------------------|---------------|-----|-----|------|
| C_{IN} | Input Capacitance | $V_{IN} = 0$ | 6 | 7.5 | pF |
| C_{OUT} | Output Capacitance | $V_{OUT} = 0$ | 8.5 | 12 | pF |
| C_{IN2} | Control Pin Capacitance | $V_{IN} = 0$ | 7.5 | 9 | pF |

Notes:

1. Sampled, not 100% tested.
2. Test conditions $T_A = 25^\circ\text{C}$, $f = 1.0\text{ MHz}$.

DATA RETENTION

| Parameter Description | Test Conditions | Min | Unit |
|-------------------------------------|-----------------|-----|-------|
| Minimum Pattern Data Retention Time | 150°C | 10 | Years |
| | 125°C | 20 | Years |

PHYSICAL DIMENSIONS

TS 048—48-Pin Standard Thin Small Outline Package

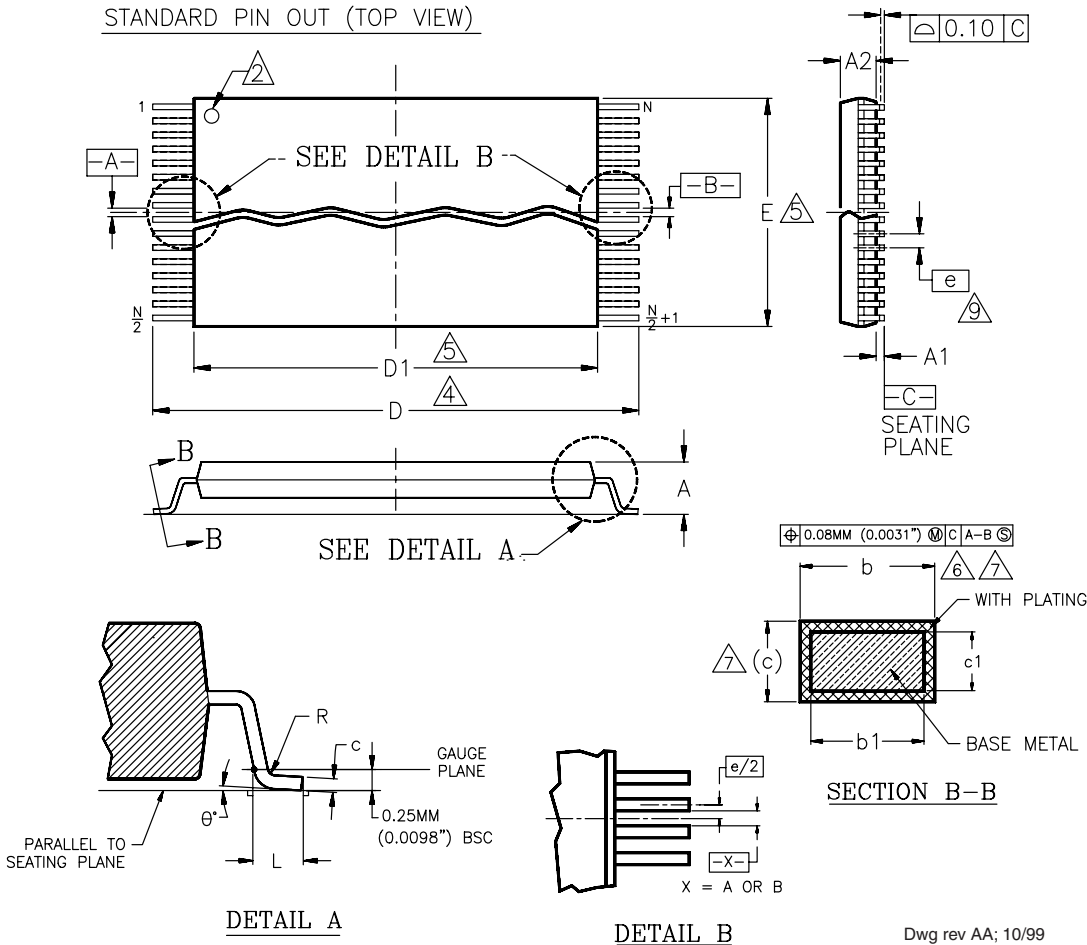

Dwg rev AA; 10/99

| Package | TS 48 | | |
|---------|---------------|-------|-------|
| Jedec | MO-142 (B) DD | | |
| Symbol | MIN | NOM | MAX |
| A | — | — | 1.20 |
| A1 | 0.05 | — | 0.15 |
| A2 | 0.95 | 1.00 | 1.05 |
| b1 | 0.17 | 0.20 | 0.23 |
| b | 0.17 | 0.22 | 0.27 |
| c1 | 0.10 | — | 0.16 |
| c | 0.10 | — | 0.21 |
| D | 19.80 | 20.00 | 20.20 |
| D1 | 18.30 | 18.40 | 18.50 |
| E | 11.90 | 12.00 | 12.10 |
| e | 0.50 BASIC | | |
| L | 0.50 | 0.60 | 0.70 |
| θ | 0° | 3° | 5° |
| R | 0.08 | — | 0.20 |
| N | 48 | | |

NOTES:

- 1. CONTROLLING DIMENSIONS ARE IN MILLIMETERS (mm). (DIMENSIONING AND TOLERANCING CONFORMS TO ANSI Y14.5M-1982)
- 2. PIN 1 IDENTIFIER FOR STANDARD PIN OUT (DIE UP).
- 3. PIN 1 IDENTIFIER FOR REVERSE PIN OUT (DIE DOWN); INK OR LASER MARK.
- 4. TO BE DETERMINED AT THE SEATING PLANE [-C-]. THE SEATING PLANE IS DEFINED AS THE PLANE OF CONTACT THAT IS MADE WHEN THE PACKAGE LEADS ARE ALLOWED TO REST FREELY ON A FLAT HORIZONTAL SURFACE.
- 5. DIMENSIONS D1 AND E DO NOT INCLUDE MOLD PROTRUSION. ALLOWABLE MOLD PROTRUSION IS 0.15mm (0.0059") PER SIDE.
- 6. DIMENSION b DOES NOT INCLUDE DAMBAR PROTRUSION. ALLOWABLE DAMBAR PROTRUSION SHALL BE 0.08mm (0.0031") TOTAL IN EXCESS OF b DIMENSION AT MAX. MATERIAL CONDITION. MINIMUM SPACE BETWEEN PROTRUSION AND AN ADJACENT LEAD TO BE 0.07mm (0.0028").
- 7. THESE DIMENSIONS APPLY TO THE FLAT SECTION OF THE LEAD BETWEEN 0.10mm (0.0039") AND 0.25mm (0.0098") FROM THE LEAD TIP.
- 8. LEAD COPLANARITY SHALL BE WITHIN 0.10mm (0.004") AS MEASURED FROM THE SEATING PLANE.
- 9. DIMENSION "e" IS MEASURED AT THE CENTERLINE OF THE LEADS.

PHYSICAL DIMENSIONS

TSR048—48-Pin Reverse Thin Small Outline Package

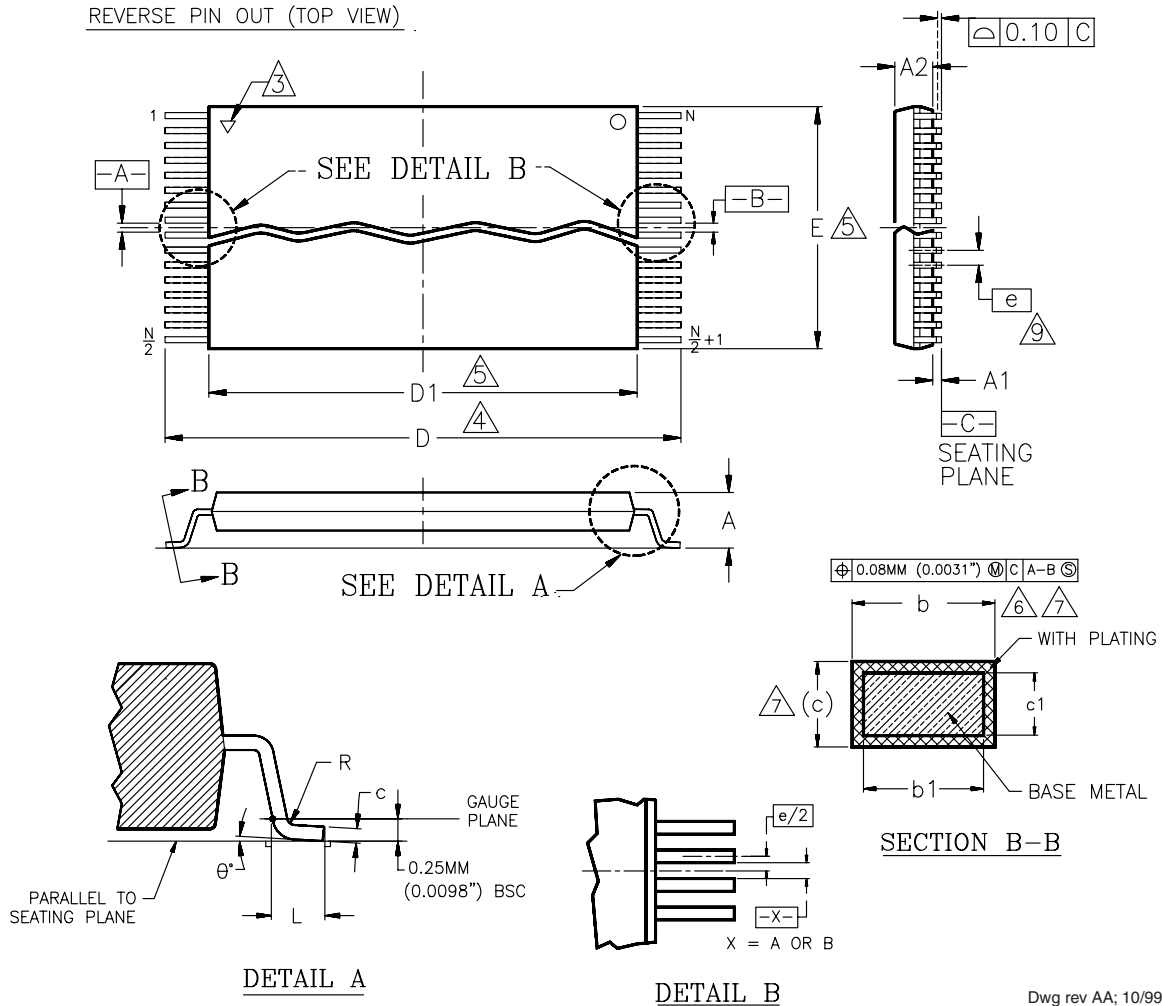

Dwg rev AA; 10/99

| Package | TSR 48 | | |
|---------|---------------|-------|-------|
| Jedec | MO-142 (B) DD | | |
| Symbol | MIN | NOM | MAX |
| A | — | — | 1.20 |
| A1 | 0.05 | — | 0.15 |
| A2 | 0.95 | 1.00 | 1.05 |
| b1 | 0.17 | 0.20 | 0.23 |
| b | 0.17 | 0.22 | 0.27 |
| c1 | 0.10 | — | 0.16 |
| c | 0.10 | — | 0.21 |
| D | 19.80 | 20.00 | 20.20 |
| D1 | 18.30 | 18.40 | 18.50 |
| E | 11.90 | 12.00 | 12.10 |
| e | 0.50 BASIC | | |
| L | 0.50 | 0.60 | 0.70 |
| θ | 0° | 3° | 5° |
| R | 0.08 | — | 0.20 |
| N | 48 | | |

NOTES:

1. CONTROLLING DIMENSIONS ARE IN MILLIMETERS (mm). (DIMENSIONING AND TOLERANCING CONFORMS TO ANSI Y14.5M-1982)
2. PIN 1 IDENTIFIER FOR STANDARD PIN OUT (DIE UP).
3. PIN 1 IDENTIFIER FOR REVERSE PIN OUT (DIE DOWN); INK OR LASER MARK.
4. TO BE DETERMINED AT THE SEATING PLANE $\overline{C-C}$. THE SEATING PLANE IS DEFINED AS THE PLANE OF CONTACT THAT IS MADE WHEN THE PACKAGE LEADS ARE ALLOWED TO REST FREELY ON A FLAT HORIZONTAL SURFACE.
5. DIMENSIONS D1 AND E DO NOT INCLUDE MOLD PROTRUSION. ALLOWABLE MOLD PROTRUSION IS 0.15mm (0.0059") PER SIDE.
6. DIMENSION b DOES NOT INCLUDE DAMBAR PROTRUSION. ALLOWABLE DAMBAR PROTRUSION SHALL BE 0.08mm (0.0031") TOTAL IN EXCESS OF b DIMENSION AT MAX. MATERIAL CONDITION. MINIMUM SPACE BETWEEN PROTRUSION AND AN ADJACENT LEAD TO BE 0.07mm (0.0028").
7. THESE DIMENSIONS APPLY TO THE FLAT SECTION OF THE LEAD BETWEEN 0.10mm (0.0039") AND 0.25mm (0.0098") FROM THE LEAD TIP.
8. LEAD COPLANARITY SHALL BE WITHIN 0.10mm (0.004") AS MEASURED FROM THE SEATING PLANE.
9. DIMENSION "e" IS MEASURED AT THE CENTERLINE OF THE LEADS.

REVISION SUMMARY

Revision A (August 3, 2001)

Initial release as abbreviated Advance Information data sheet.

Revision A+1 (October 3, 2001)

Global

Added 120 ns speed option.

Ordering Information

Changed operating voltage range for 90 ns device.

Physical Dimensions

Added section.

Revision B (March 14, 2002)

Global

Expanded data sheet to full specification version.

Revision B+1 (April 26, 2002)

MirrorBit 64 Mbit Device Family

Deleted Am29LV641MT/B.

Figure 2, In-System Sector Group Protect/Unprotect Algorithms

Added A3 and A2 address requirement.

Sector Group Protection/Unprotection

Deleted reference to alternate method of sector protection.

Autoselect Command

Substituted text with ID code table for easier reference.

Table 10, Command Definitions

Combined Notes 4 and 5 from Revision B. Corrected number of cycles indicated for Write-to-Buffer and Autoselect Device ID command sequences.

Figure 25, Sector Group Protect and Unprotect Timing Diagram

In the note, added A3 and A2 address requirement.

Revision B+2 (August 1, 2002)

Mirrorbit 64 MBIT Device Family

Added 64 Fortified BGA to table.

Program Suspend/Program Resume Command Sequence

Changed program operation wait time from 1ms to 15 μ s.

Figure 5. Program Suspend/Program Resume

Changed wait from 1ms to 15 μ s.

Erase Resume/Erase Resume Commands

Added a maximum of 20 μ s.

Alternate CE# Controlled Erase and Program Operations

Added T_{RH} parameter to table.

Special package handling instructions

Modified the special handling wording.

DC Characteristics table

Deleted the I_{ACC} specification row.

CFI

Changed text in the third paragraph of CFI to read "reading array data."

Revision B+3 (September 10, 2002)

Product Selector Guide

Added Note 2.

Ordering Information

Added Note 1.

Sector Erase Command Sequence

Deleted statement that describes the outcome of when the Embedded Erase operation is in progress.

Revision B+4 (October 15, 2002)

Erase and Programming Performance

Changed values for typical and maximum times on word program time and write buffer program time to TBD. Inserted TBD for maximum chip erase time.

Revision B+5 (November 26, 2002)

Product Selector Guide and Read-Only Characteristics

Added a 30 ns option to t_{PACC} and t_{OE} standard for the 112R and 120R speed options.

Customer Lockable: SecSi Sector NOT Programmed or Protected at the factory.

Added second bullet, SecSi sector-protect verify text and figure 3.

SecSi Sector Flash Memory Region, and Enter SecSi Sector/Exit SecSi Sector Command Sequence

Noted that the ACC function and unlock bypass modes are not available when the SecSi sector is enabled.

Byte/Word Program Command Sequence, Sector Erase Command Sequence, and Chip Erase Command Sequence

Noted that the SecSi Sector, autoselect, and CFI functions are unavailable when a program or erase operation is in progress.

Common Flash Memory Interface (CFI)

Changed CFI website address

Figure 6. Program Suspend/Program Resume

Change wait time to 15 μ s.

CMOS Compatible

Added I_{LR} row to table

Changed V_{IH1} and V_{IH2} minimum to 1.9.

Removed typos in notes.

Hardware Reset, CMOS Tables, Erase and Program Operations, Temporary Sector Unprotect, and Alternate CE# Controlled Erase and Program Operations

Added Note.

Revision B+6 (February 16, 2003)**Distinctive Characteristics**

Corrected performance characteristics.

Product Selector Guide

Added note 3.

Ordering Information

Corrected Valid Combination to reflect speed option changes.

Added Note.

AC Characteristics

Removed 90, 90R speed option.

Added Note

Input values in the t_{WHWH1} and t_{WHWH2} parameters in the Erase and Program Options table that were previously TBD. Also added notes 5 and 6.

Input values in the t_{WHWH1} and t_{WHWH2} parameters in the Alternate CE# Controlled Erase and Program Options table that were previously TBD. Also added notes 5.

Erase and Programming Performance

Input values into table that were previously TBD.

Added note 3 and 4.

Revision B+7 (June 12, 2003)**Ordering Information**

Added 90R speed grade, modified note.

Erase and programming Performance

Modified table, inserted values for Typical.

Revision B+8 (February 13, 2004)**Table 1 Device Bus Operations**

Modified ACC column, replaced instances of X to L/H.

Word/Byte Program Command Sequence

Removed reference to byte.

Erase Suspend/Erase Resume Commands

Added note on flash device performance during suspend/erase mode.

Table 10 Command Definitions

Modified Program/Erase Suspend and Program/Erase Resume from BA to XXX (Don't Care).

AC Characteristics - Erase and Program Operations

Added t_{POLL} information and note.

AC Characteristics - Alternate CE# Controlled Erase and Program Operations

Added t_{POLL} information and note.

AC Characteristics Figures

Added t_{POLL} timing to Figure 18, [Program Operation Timings](#); Figure 21, [Data# Polling Timings \(During Embedded Algorithms\)](#); and Figure 26, [Alternate CE# Controlled Write \(Erase/Program\) Operation Timings](#).

Erase and Programming Performance

Removed reference to byte.

Trademarks

Updated.

Revision B+9 (August 23, 2004)

Added Max programming specifications.

Added notation referencing superseding documentation.

Revision B+10 (December 21, 2005)**Global**

This product has been retired and is not available for designs. For new and current designs, S29GL064A supersedes Am29LV641M H/L and is the factory-recommended migration path. Please refer to the S29GL064A datasheet for specifications and ordering information. Availability of this document is retained for reference and historical purposes only.

Colophon

The products described in this document are designed, developed and manufactured as contemplated for general use, including without limitation, ordinary industrial use, general office use, personal use, and household use, but are not designed, developed and manufactured as contemplated (1) for any use that includes fatal risks or dangers that, unless extremely high safety is secured, could have a serious effect to the public, and could lead directly to death, personal injury, severe physical damage or other loss (i.e., nuclear reaction control in nuclear facility, aircraft flight control, air traffic control, mass transport control, medical life support system, missile launch control in weapon system), or (2) for any use where chance of failure is intolerable (i.e., submersible repeater and artificial satellite). Please note that Spansion will not be liable to you and/or any third party for any claims or damages arising in connection with above-mentioned uses of the products. Any semiconductor devices have an inherent chance of failure. You must protect against injury, damage or loss from such failures by incorporating safety design measures into your facility and equipment such as redundancy, fire protection, and prevention of over-current levels and other abnormal operating conditions. If any products described in this document represent goods or technologies subject to certain restrictions on export under the Foreign Exchange and Foreign Trade Law of Japan, the US Export Administration Regulations or the applicable laws of any other country, the prior authorization by the respective government entity will be required for export of those products.

Trademarks

Copyright © 2004-2005 Advanced Micro Devices, Inc. All rights reserved.

AMD, the AMD logo, and combinations thereof are registered trademarks of Advanced Micro Devices, Inc.

ExpressFlash is a trademark of Advanced Micro Devices, Inc.

Product names used in this publication are for identification purposes only and may be trademarks of their respective companies.