

## Negative Voltage Regulators

### ■ GENERAL DESCRIPTION

The XC62K series are highly precise, low power consumption, negative voltage regulators, manufactured using CMOS and laser trimming technologies. The series achieves high output currents with small input-output voltage differentials, and consists of a high precision voltage reference, an error correction circuit, and an output driver with current limitation. SOT-23 (150mW), SOT-89 (500mW), USP-6B (100mW) and TO-92 (300mW) packages are available.

### ■ APPLICATIONS

- Battery powered equipment
- Portable & cellular phones
- Various portable equipment
- Power supply for GaAs applications

### ■ FEATURES

- Dropout Voltage** : 0.12V@50mA ( $V_{OUT}=-5.0V$ )  
: 0.38V@100mA
- Maximum Output Current** : 100mA (within MAX. power dissipation,  $V_{OUT}=-5.0V$ )
- Output Voltage Range** : -2.1V ~ -6.0V in 100mV increments  
-5.0, -4.0, -3.0V, -2.5V standard  
(All other voltages are semi-custom)
- Highly Accurate** : Setting output voltage  $\pm 2\%$   
( $\pm 1\%$  for semi-custom products)
- Low Power Consumption** : 3.0  $\mu A$  @  $V_{OUT}=-5.0V$  (TYP.)
- Output Voltage Temperature Characteristics**  
:  $\pm 100ppm/^{\circ}C$  (TYP.)
- Line Regulation** : 0.1%/V (TYP.)
- CMOS Low Power Consumption**
- Ultra Small Packages** : SOT-23 (150mW) mini-mold,  
SOT-89 (500mW) mini-power mold  
TO-92 (300mW)  
USP-6B (100mW)

### ■ TYPICAL APPLICATION CIRCUIT

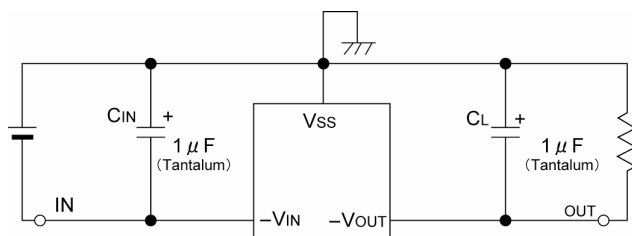

### ■ TYPICAL PERFORMANCE CHARACTERISTICS

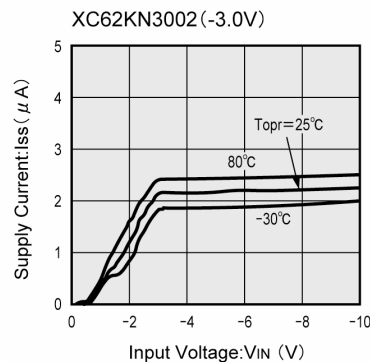

## PIN CONFIGURATION

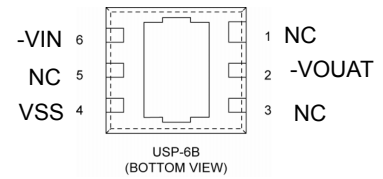
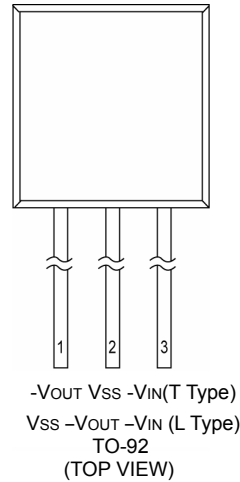
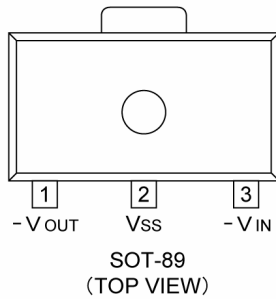
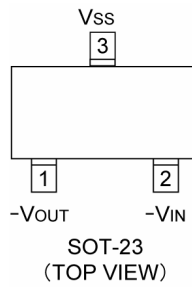

\*The dissipation pad for the USP-6B package should be solder-plated in recommended mount pattern and metal masking so as to enhance mounting strength and heat release.  
If the pad needs to be connected to other pins, it should be connected to the VSS pin.

## PIN ASSIGNMENT

PIN NUMBER				PIN NAME	FUNCTION
SOT-23	SOT-89/TO-92 (T)	TO-92 (L)	USP-6B		
2	3	3	6	-VIN	Power Supply Input
3	2	1	4	VSS	Ground
1	1	2	2	-VOUT	Output
—	—	—	1.3.5	NC	No Connection

## PRODUCT CLASSIFICATION

### Ordering Information

XC62K①②③④⑤⑥⑦

MARK	DESCRIPTION	SYMBOL	DESCRIPTION
①	Polarity of Output Voltage	N	: Negative
② ③	Output Voltage	21 ~ 60	: e.g. V <sub>OUT</sub> = 2.1V → ②=2, ③=1 V <sub>OUT</sub> = 6.0V → ②=6, ③=0
④	Temperature Characteristics	0	: ± 100ppm (TYP.)
⑤	Output Voltage Accuracy	1	: ± 1% (Semi-custom)
		2	: ± 2%
⑥	Package	M	: SOT-23
		P	: SOT-89
		T	: TO-92 (Standard)
		L	: TO-92 (Custom pin configuration)
		D	: USP-6B
⑦	Device Orientation	R	: Embossed tape, standard feed
		L	: Embossed tape, reverse feed
		H	: Paper type (TO-92)
		B	: Bag (TO-92)

## ■ BLOCK DIAGRAM

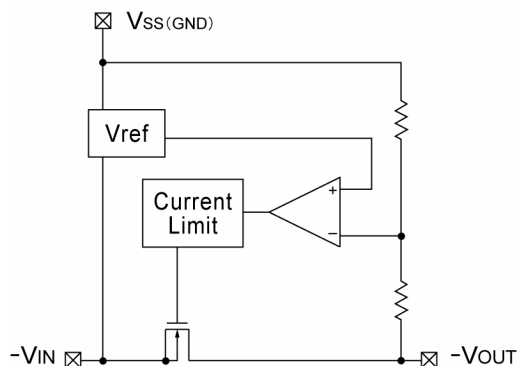

## ■ ABSOLUTE MAXIMUM RATINGS

			Ta=25°C	
PARAMETER	SYMBOL	RATINGS	UNITS	
Input Voltage	VIN	-12.0	V	
Output Current	IOUT	200	mA	
Output Voltage	VOUT	-VDD-0.3~VIN+0.3	V	
Power Dissipation	SOT-23	Pd	150	
	SOT-89		500	
	TO-92		300	
	USP-6B		100	
Operating Temperature Range	Topr	-30 ~ +80	°C	
Storage Temperature Range	Tstg	-40 ~ +125	°C	

Note: Please ensure that IOUT is less than Pd/(VOUT-VIN).

## ELECTRICAL CHARACTERISTICS

XC62KN5002

V<sub>OUT(T)</sub> = -5.0V

T<sub>a</sub> = 25°C

PARAMETER	SYMBOL	CONDITIONS	MIN.	TYP.	MAX.	UNITS	CIRCUIT
Output Voltage (*2)	V <sub>OUT(E)</sub>	I <sub>OUT</sub> = 20mA V <sub>IN</sub> = -6.0V	x 0.98 -4.90	V <sub>OUT(T)</sub> -5.00	x 1.02 -5.10	V	2
Maximum Output Current	I <sub>OUT max</sub>	V <sub>IN</sub> = -6.0V, V <sub>OUT(E)</sub> ≥ -4.5V	100	-	-	mA	4
Load Regulation	ΔV <sub>OUT</sub>	V <sub>IN</sub> = 6.0V 1mA ≤ I <sub>OUT</sub> ≤ 50mA	-	40	80	mV	4
Dropout Voltage (*3)	V <sub>dif</sub>	I <sub>OUT</sub> = 50mA	-	120	300	mV	3
		I <sub>OUT</sub> = 100mA	-	380	600		
Supply Current	I <sub>SS</sub>	V <sub>IN</sub> = -6.0V	-	3.0	7.0	μA	1
Line Regulation	$\frac{\Delta V_{OUT}}{\Delta V_{IN} \cdot V_{OUT}}$	I <sub>OUT</sub> = 20mA -6.0V ≤ V <sub>IN</sub> ≤ -10.0V	-	0.1	0.3	%V	3
Input Voltage	V <sub>IN</sub>	-	-	-	-10.0	V	-
Output Voltage Temperature Characteristics	$\frac{\Delta V_{OUT}}{\Delta V_{IN} \cdot V_{OUT}}$	I <sub>OUT</sub> = 20mA -30°C ≤ T <sub>opr</sub> ≤ 80°C	-	±100	-	ppm/°C	-

XC62KN4002

V<sub>OUT(T)</sub> = -4.0V

T<sub>a</sub> = 25°C

PARAMETER	SYMBOL	CONDITIONS	MIN.	TYP.	MAX.	UNITS	CIRCUIT
Output Voltage (*2)	V <sub>OUT(E)</sub>	I <sub>OUT</sub> = 20mA V <sub>IN</sub> = -5.0V	x 0.98 -3.92	V <sub>OUT(T)</sub> -4.00	x 1.02 -4.08	V	2
Maximum Output Current	I <sub>OUT max</sub>	V <sub>IN</sub> = -5.0V, V <sub>OUT(E)</sub> ≥ -3.6V	80	-	-	mA	4
Load Regulation	ΔV <sub>OUT</sub>	V <sub>IN</sub> = -5.0V 1mA ≤ I <sub>OUT</sub> ≤ 45mA	-	40	80	mV	4
Dropout Voltage (*3)	V <sub>dif</sub>	I <sub>OUT</sub> = 45mA	-	120	300	mV	3
		I <sub>OUT</sub> = 90mA	-	380	600		
Supply Current	I <sub>SS</sub>	V <sub>IN</sub> = -5.0V	-	3.0	6.5	μA	1
Line Regulation	$\frac{\Delta V_{OUT}}{\Delta V_{IN} \cdot V_{OUT}}$	I <sub>OUT</sub> = 20mA -5.0V ≤ V <sub>IN</sub> ≤ -10.0V	-	0.1	0.3	%V	3
Input Voltage	V <sub>IN</sub>	-	-	-	-10.0	V	-
Output Voltage Temperature Characteristics	$\frac{\Delta V_{OUT}}{\Delta V_{IN} \cdot V_{OUT}}$	I <sub>OUT</sub> = 20mA -30°C ≤ T <sub>opr</sub> ≤ 80°C	-	±100	-	ppm/°C	-

**NOTE:**

\*1: V<sub>OUT(T)</sub> = Specified output voltage

\*2: V<sub>OUT(E)</sub> = Effective output voltage (i.e. the output voltage when "V<sub>OUT(T)</sub> - 1.0V" is provided at the V<sub>IN</sub> pin while maintaining a certain I<sub>OUT</sub> value).

\*3: V<sub>dif</sub> = {V<sub>IN1</sub> - V<sub>OUT1</sub>}

\*4: V<sub>OUT1</sub> = A voltage equal to 98% of the output voltage whenever an amply stabilized I<sub>OUT</sub> {V<sub>OUT(T)</sub> - 1.0V} is input.

\*5: V<sub>IN1</sub> = The input voltage when a voltage equal to 98% of V<sub>OUT(E)</sub> appears. (Input voltage is gradually decreased.)

\*6: I<sub>OUTMAX</sub> = Please ensure that output current is within the values given for power dissipation.

## ■ ELECTRICAL CHARACTERISTICS (Continued)

XC62KN3002

$V_{OUT(T)} = -3.0V$

$T_a = 25^\circ C$

PARAMETER	SYMBOL	CONDITIONS	MIN.	TYP.	MAX.	UNITS	CIRCUIT
Output Voltage (*2)	$V_{OUT(E)}$	$I_{OUT} = 20mA$ $V_{IN} = -4.0V$	$\times 0.98$ -2.94	$V_{OUT(T)}$ -3.00	$\times 1.02$ -3.06	V	2
MAX. Output Current	$I_{OUT\ max}$	$V_{IN} = -4.0V, V_{OUT(E)} \geq -2.7V$	60	-	-	mA	4
Load Regulation	$\Delta V_{OUT}$	$V_{IN} = -4.0V$ $1mA \leq I_{OUT} \leq 40mA$	-	40	80	mV	4
Dropout Voltage	$V_{dif}$	$I_{OUT} = 40mA$	-	120	300	mV	3
		$I_{OUT} = 80mA$	-	380	600		
Supply Current	$I_{SS}$	$V_{IN} = 4.0V$	-	2.5	6.0	$\mu A$	1
Line Regulation	$\frac{\Delta V_{OUT}}{\Delta V_{IN} \cdot V_{OUT}}$	$I_{OUT} = 20mA$ $-4.0V \leq V_{IN} \leq -10.0V$	-	0.1	0.3	%V	3
Input Voltage	$V_{IN}$	-	-	-	-10.0	V	-
Output Voltage Temperature Characteristics	$\frac{\Delta V_{OUT}}{\Delta V_{IN} \cdot V_{OUT}}$	$I_{OUT} = 20mA$ $-30^\circ C \leq T_{opr} \leq 80^\circ C$	-	$\pm 100$	-	ppm/ $^\circ C$	-

**NOTE:**

- \*1:  $V_{OUT(T)}$  = Specified output voltage
- \*2:  $V_{OUT(E)}$  = Effective output voltage (i.e. the output voltage when " $V_{OUT(T)} - 1.0V$ " is provided at the  $V_{IN}$  pin while maintaining a certain  $I_{OUT}$  value).
- \*3:  $V_{dif} = \{V_{IN1} - V_{OUT1}\}$
- \*4:  $V_{OUT1}$  = A voltage equal to 98% of the output voltage whenever an amply stabilized  $I_{OUT}$  ( $V_{OUT(T)} - 1.0V$ ) is input.
- \*5:  $V_{IN1}$  = The input voltage when a voltage equal to 98% of  $V_{OUT(E)}$  appears. (Input voltage is gradually decreased.)
- \*6:  $I_{OUT\ MAX}$  = Please ensure that output current is within the values given for power dissipation.

## ■ TYPICAL APPLICATION CIRCUIT

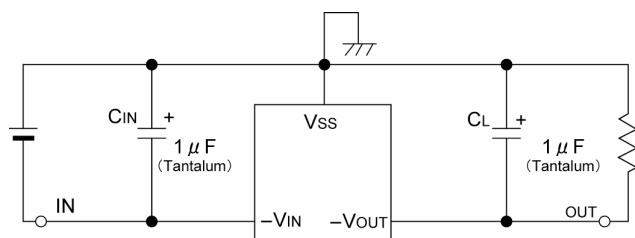

## ■ NOTES ON USE

Please ensure that values for input capacitance,  $C_{IN}$  and out capacitance,  $C_L$ , are more than  $1 \mu F$  (Tantalum).

## TEST CIRCUITS

Circuit 1. Supply Current

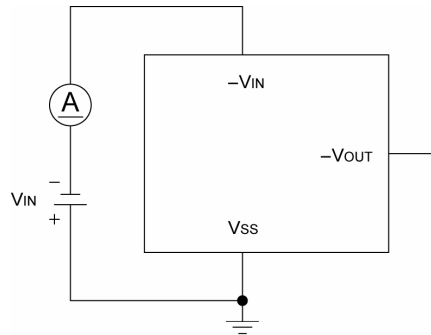

Circuit 2. Output Voltage

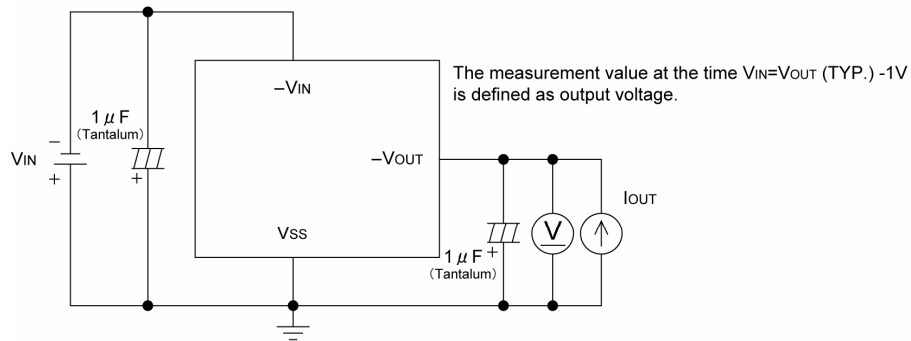

Circuit 3. Line Regulation Dropout Voltage

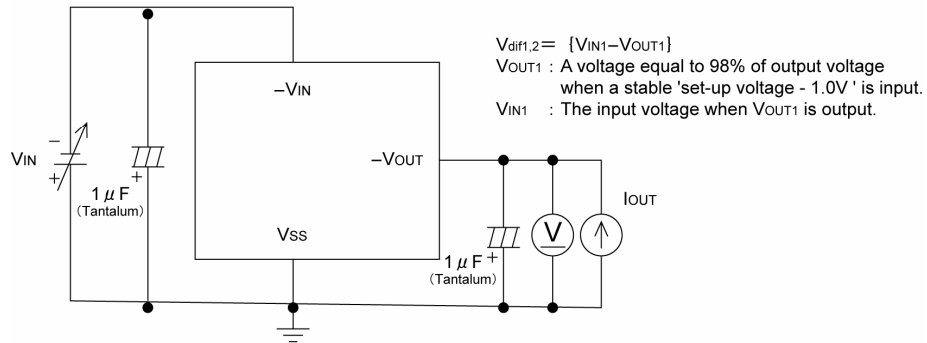

Circuit 4. Load Regulation, Maximum Output Current

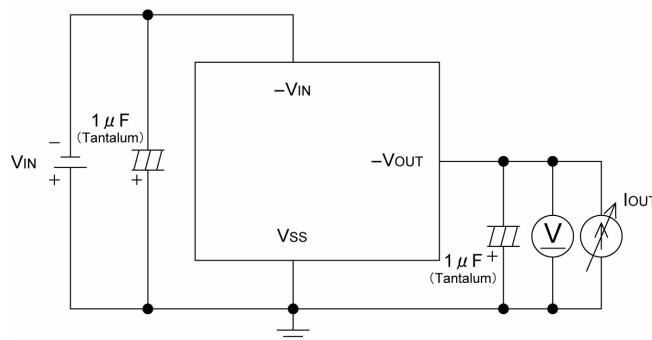

## TYPICAL PERFORMANCE CHARACTERISTICS

### (1) Output Voltage vs. Output Current

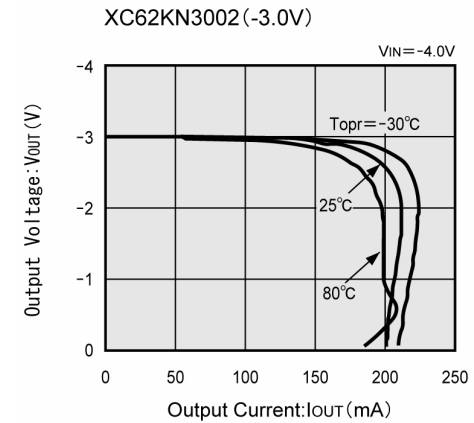
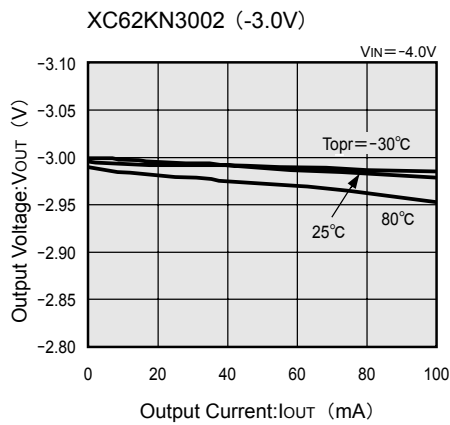
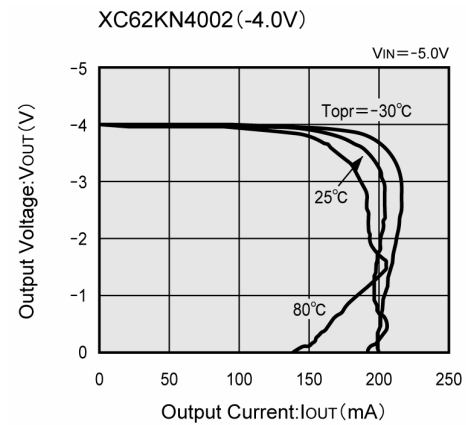
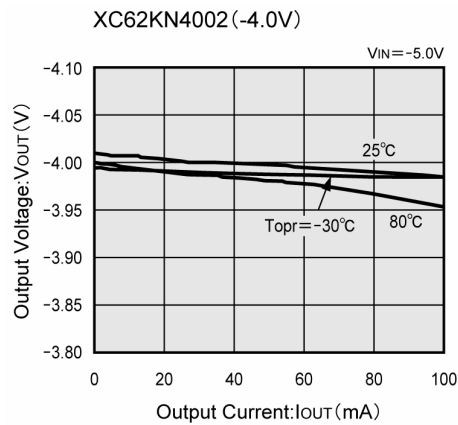
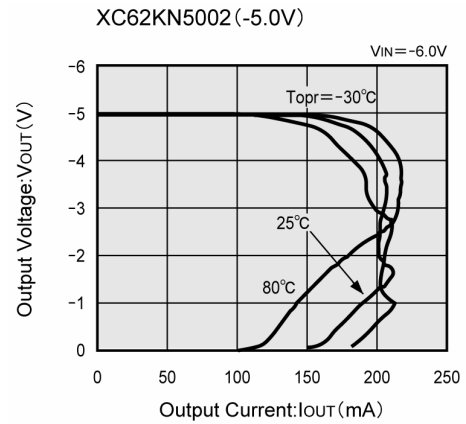
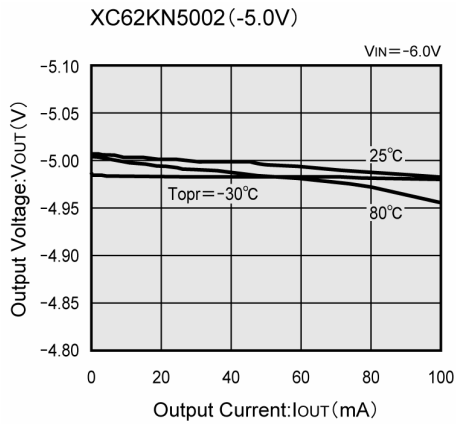

## TYPICAL PERFORMANCE CHARACTERISTICS (Continued)

### (2) Output Voltage vs. Input Voltage

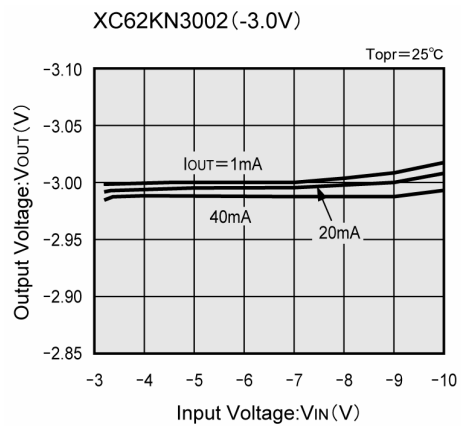
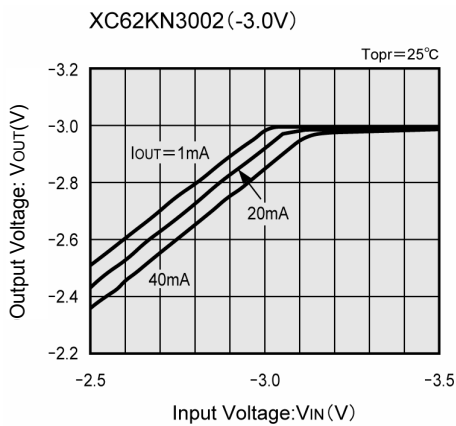
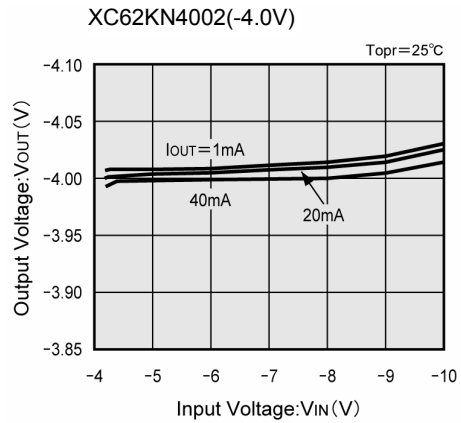
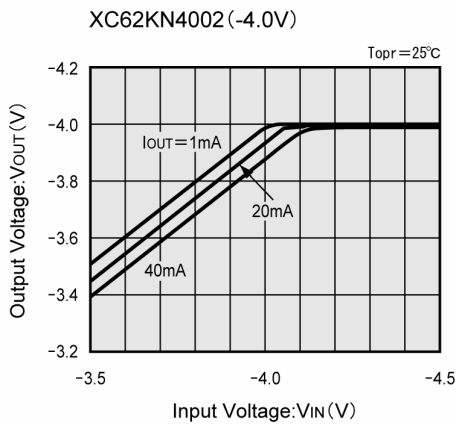
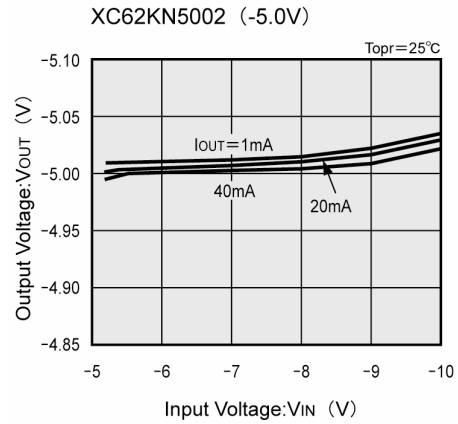
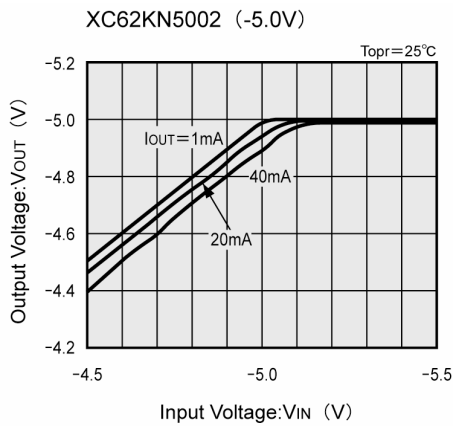



## ■ TYPICAL PERFORMANCE CHARACTERISTICS (Continued)

### (3) Dropout Voltage vs. Output Current

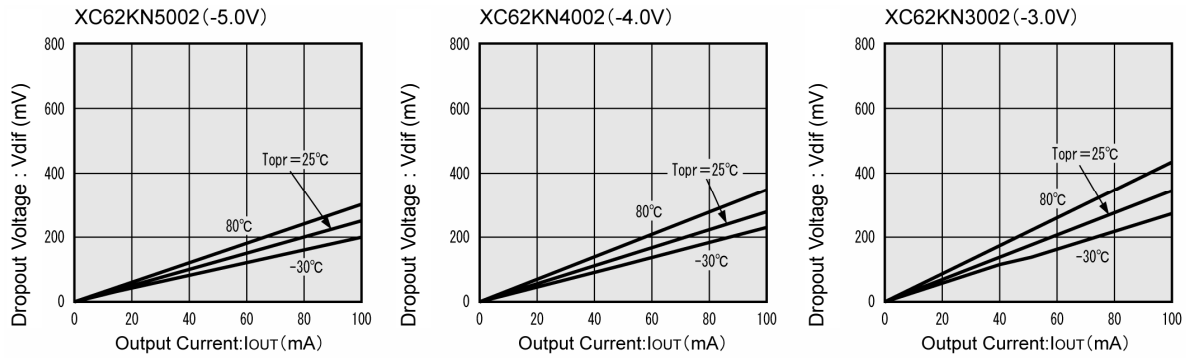

### (4) Supply Current vs. Input Voltage

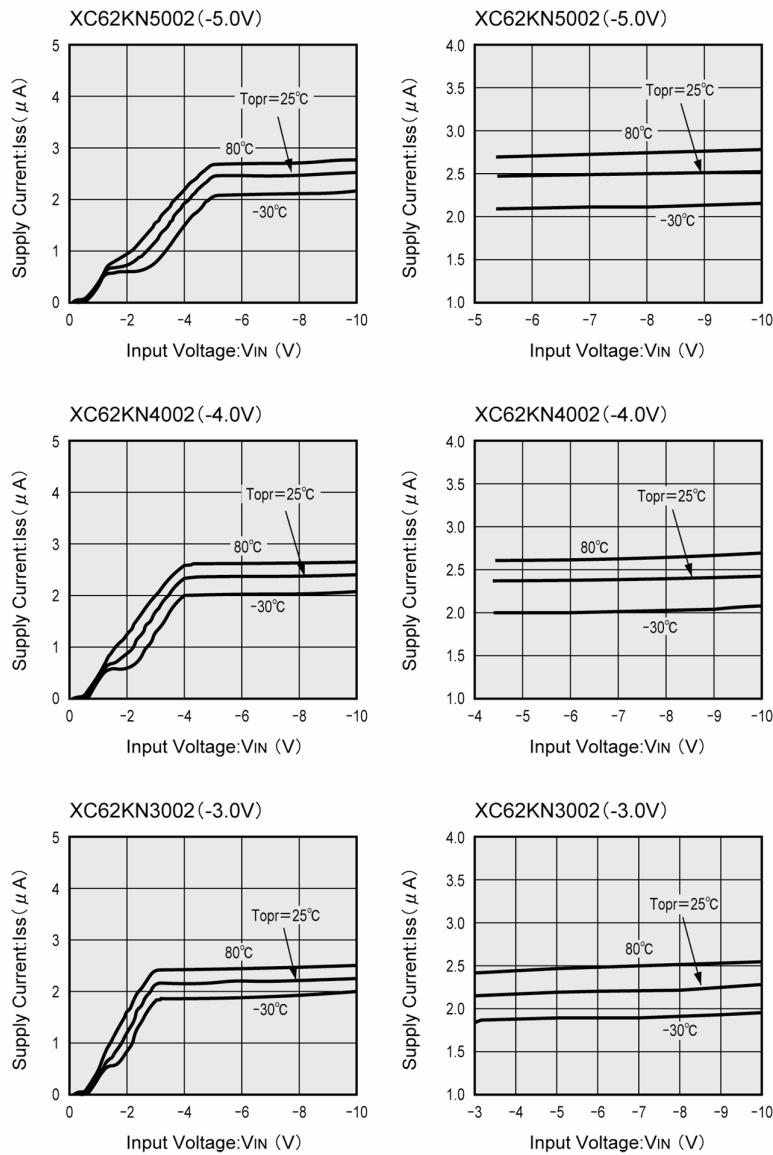

## TYPICAL PERFORMANCE CHARACTERISTICS (Continued)

### (5) Output Voltage vs. Ambient Temperature

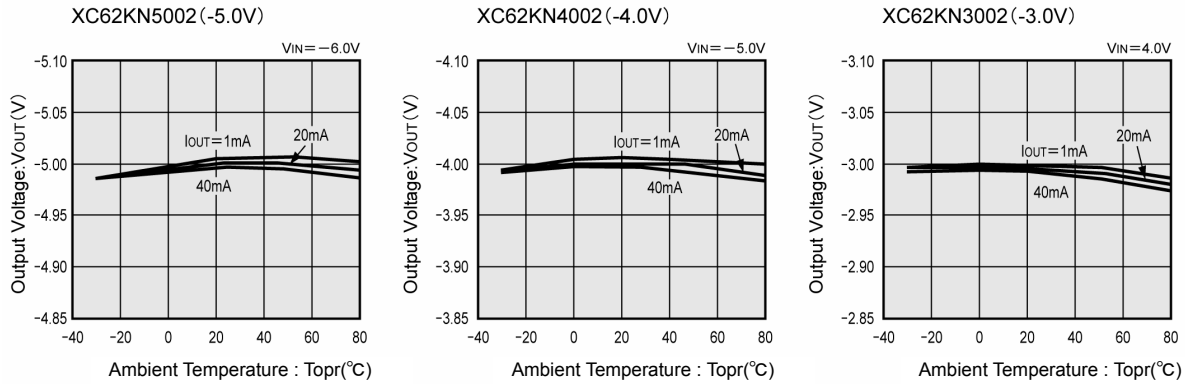

### (6) Supply Current vs. Ambient Temperature

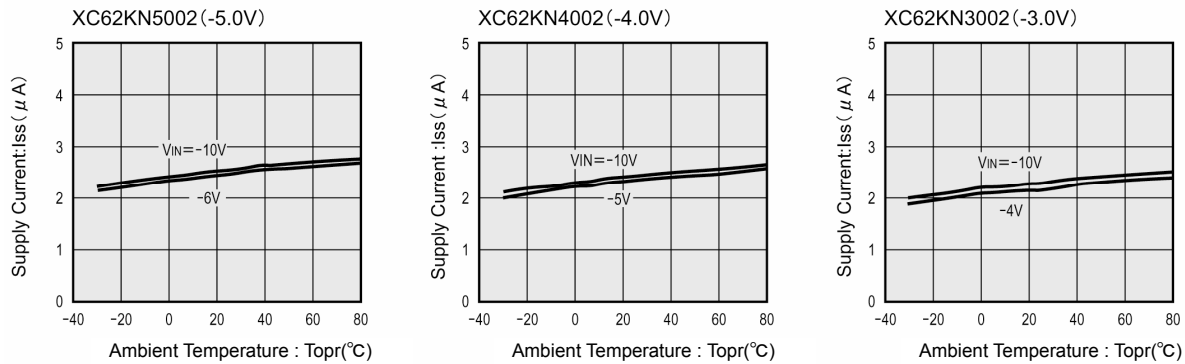

### (7) Input Transient Response 1

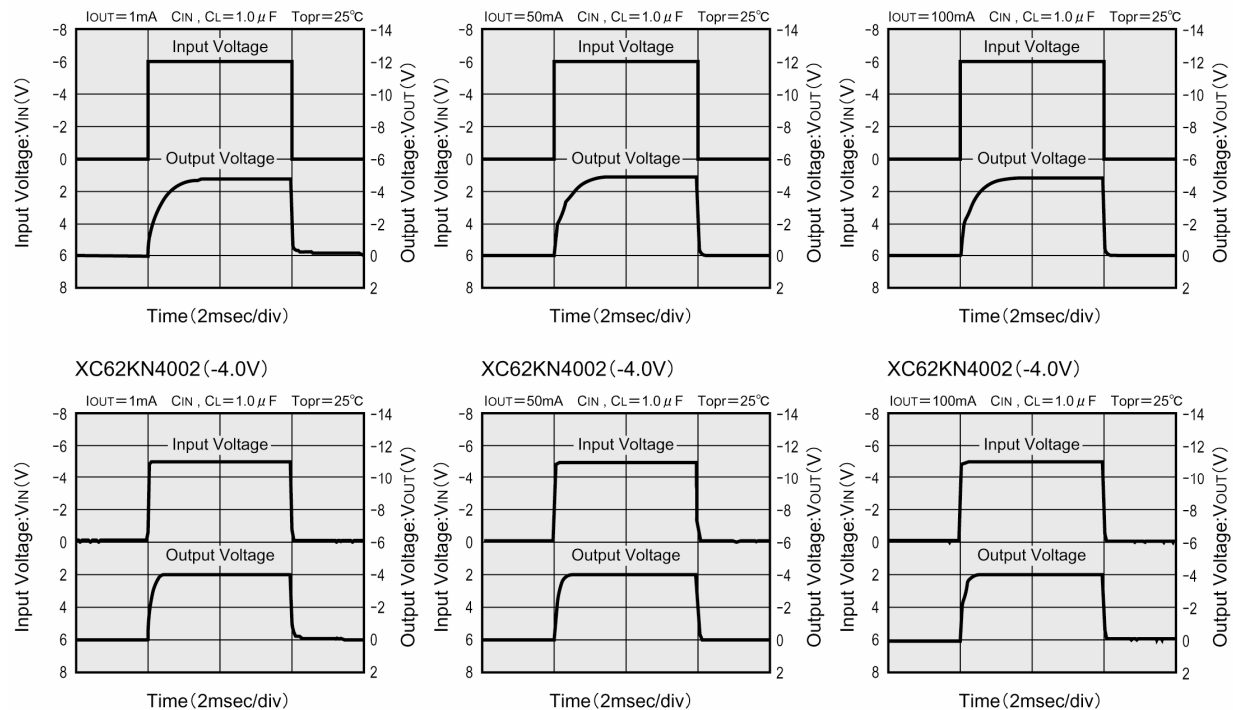

## TYPICAL PERFORMANCE CHARACTERISTICS (Continued)

### (7) Input Transient Response 1

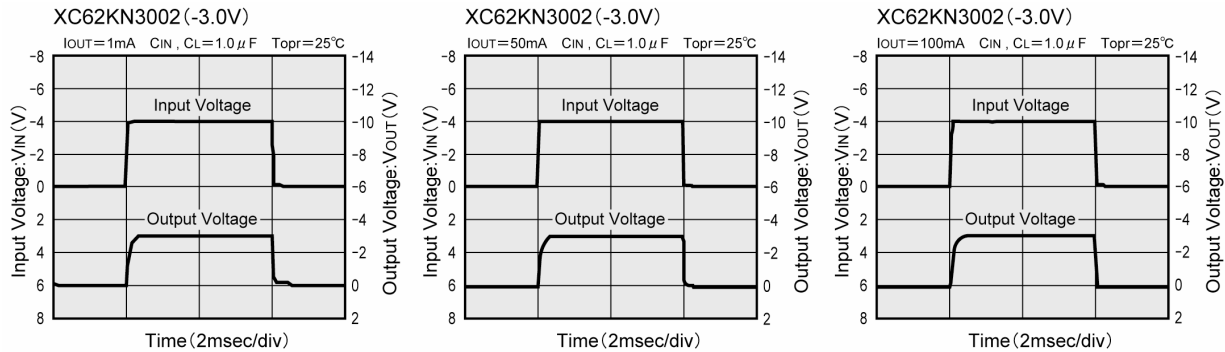

### (8) Input Transient Response 2

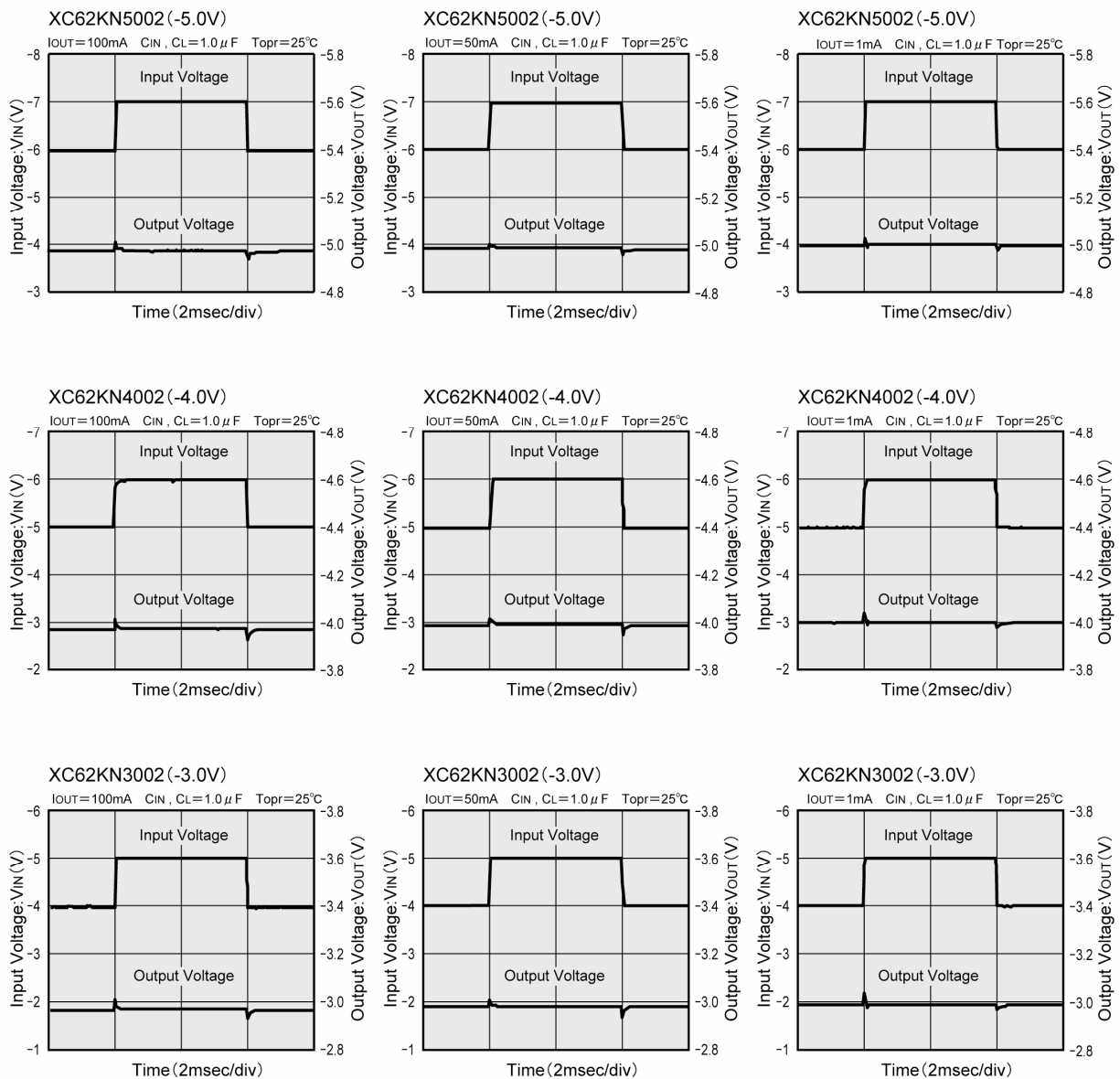

## TYPICAL PERFORMANCE CHARACTERISTICS (Continued)

### (9) Load Transient Response

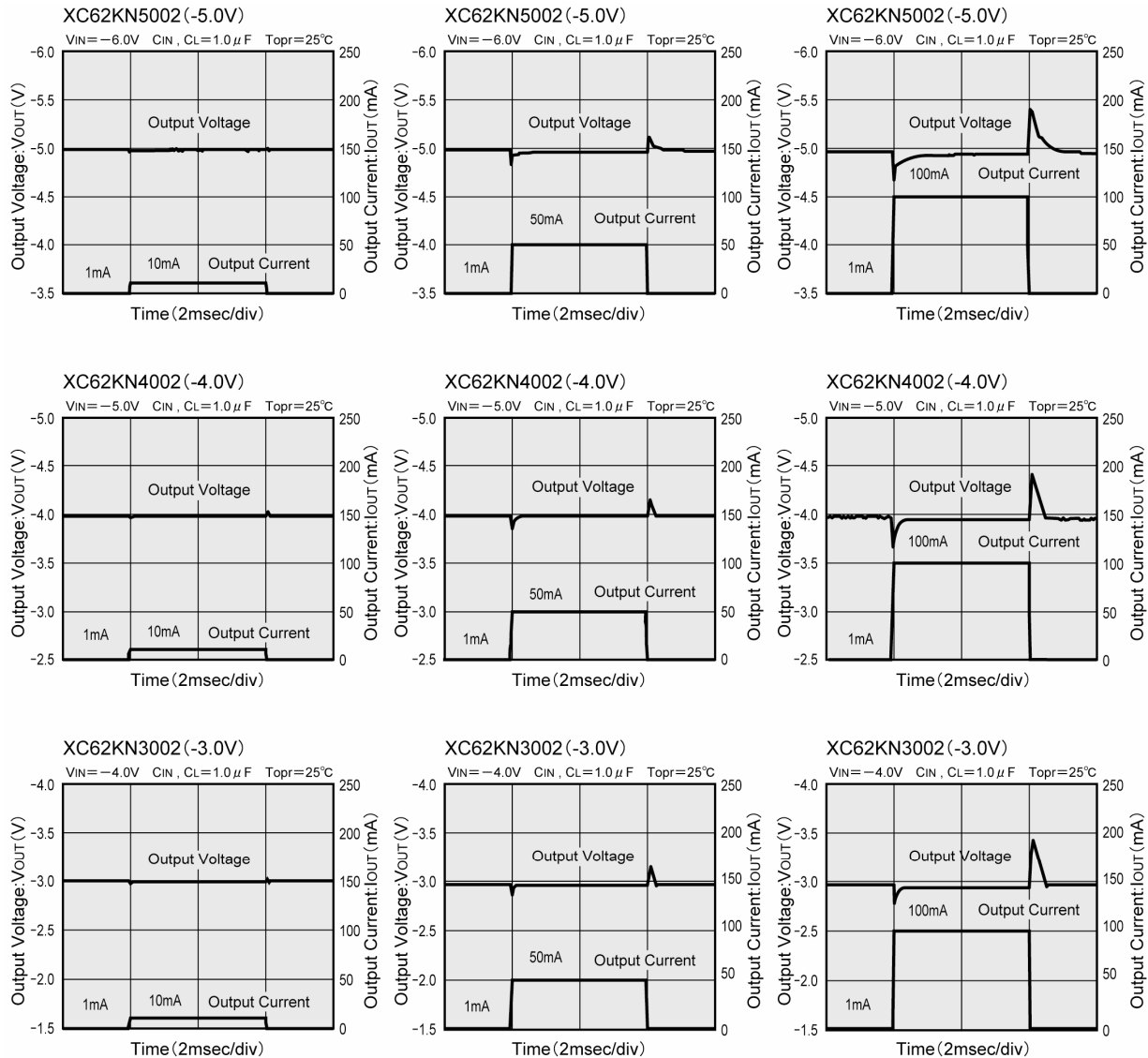

### (10) Ripple Rejection Rate

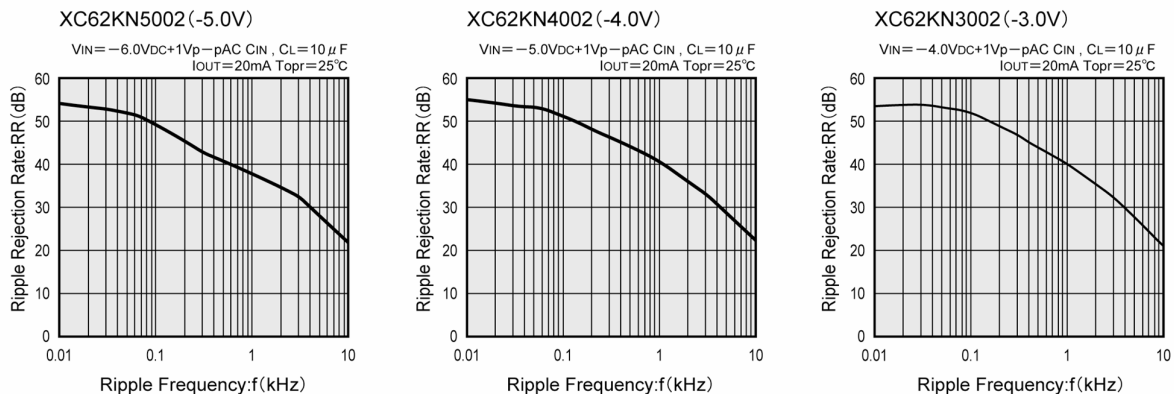

■ **PACKAGING INFORMATION**

● **SOT-23**

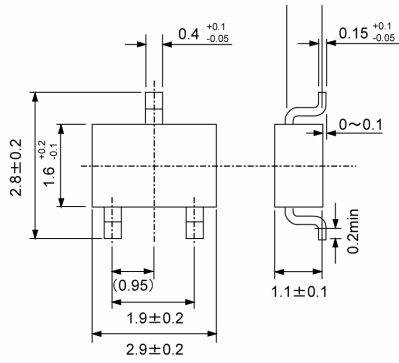

● **SOT-89**

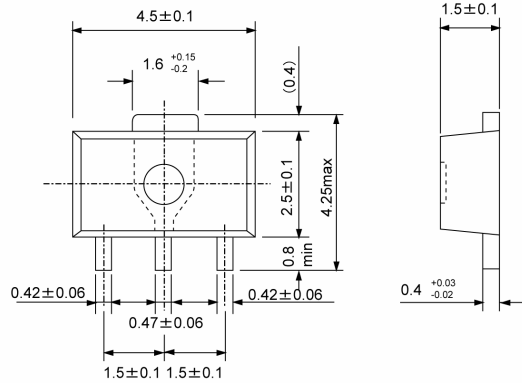

● **TO-92**

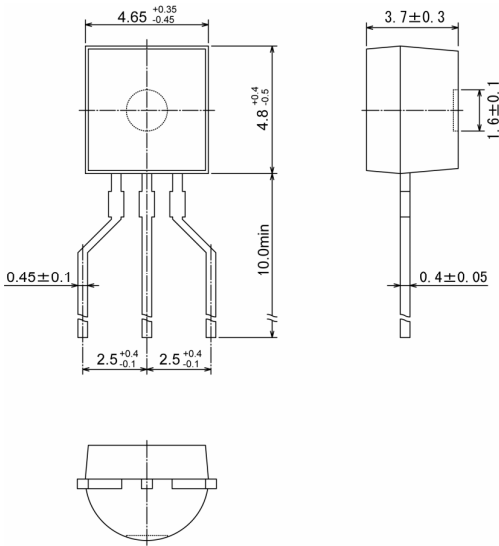

● **USP-6B**

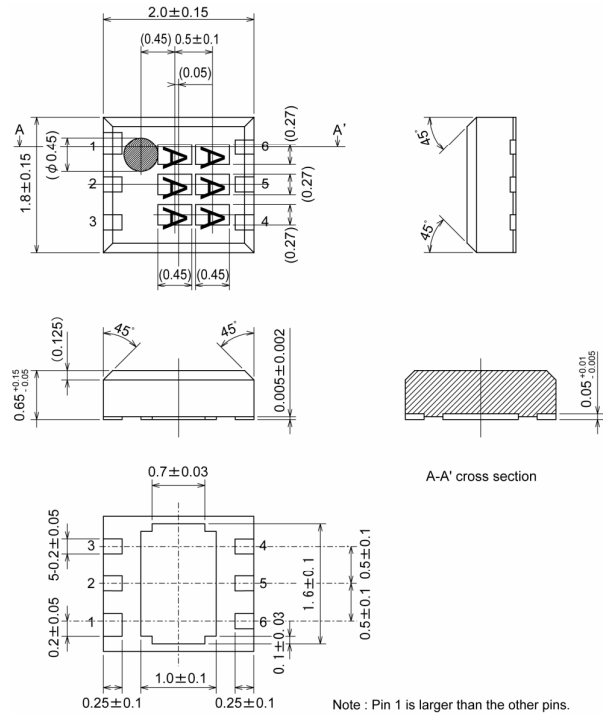

## PACKAGING INFORMATION (Continued)

● USP-6B Recommended Pattern Layout

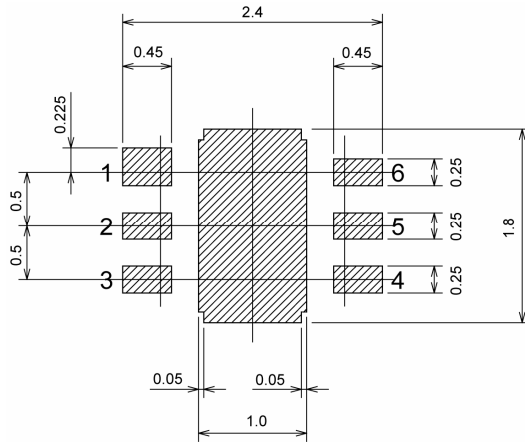

● USP-6B Recommended Metal Mask Design

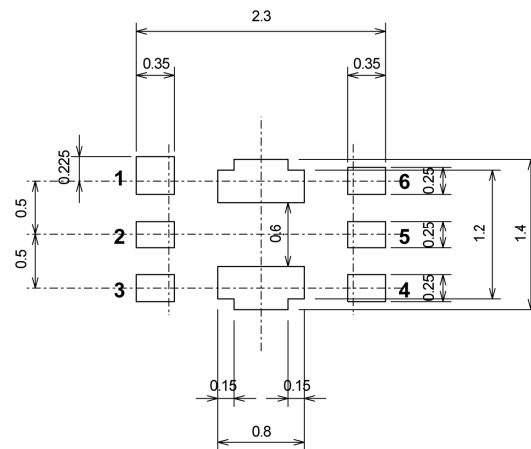

## MARKING RULE

### ● SOT-23, SOT-89

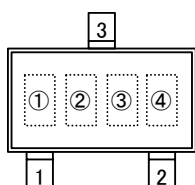

SOT-23  
(TOP VIEW)

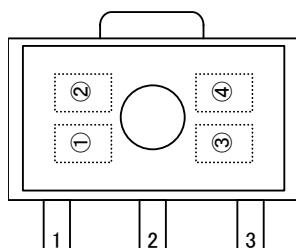

SOT-89  
(TOP VIEW)

① Represents integral number of output voltage

MARK	VOLTAGE (V)	MARK	VOLTAGE (V)
2	2.X	5	5.X
3	3.X	6	6.X
4	4.X		

② Represents decimal number of output voltage

MARK	VOLTAGE (V)	MARK	VOLTAGE (V)
A	x.0	F	x.5
B	x.1	H	x.6
C	x.2	K	x.7
D	x.3	L	x.8
E	x.4	M	x.9

③ Represents polarity of output voltage

MARK	POLARITY
5	Negative

④ Represents production lot number

0 to 9, A to Z repeated, reverse character 0 to 9, A to Z repeated  
(G, I, J, O, Q, W excepted)

### ● TO-92

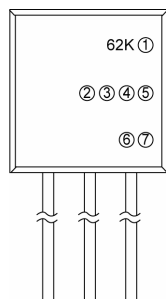

TO-92 (T Type)  
(TOP VIEW)

① Represents polarity of output voltage

MARK	OUTPUT CONFIGURATION
N	– (Negative)

②③ Represents output voltage (ex.)

MARK		VOLTAGE (V)
②	③	
3	3	3.3
5	0	5.0

④ Represents temperature characteristics

MARK	TEMPERATURE CHARACTERISTICS
0	+100 ppm (TYP.)

⑤ Represents output voltage accuracy

MARK	OUTPUT VOLTAGE ACCURACY
1	Within $\pm 1\%$ (semi-custom)
2	Within $\pm 2\%$

⑥ Represents least significant digit of production year (ex.)

MARK	PRODUCTION YEAR
3	2003
4	2004

⑦ Represents production lot number

0 to 9, A to Z repeated (G, I, J, O, Q, W excepted)

## MARKING RULE (Continued)

### ● USP-6B

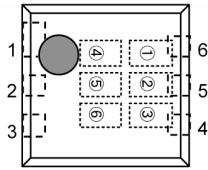

USP-6B  
(TOP VIEW)

① Represents production series

MARK	PRODUCT SERIES
K	XC62KNxx0xDx

② Represents polarity of output voltage

MARK	POLARITY	PRODUCT SERIES
N	-(Negative)	XC62KNxx0xDx

③④ Represents output voltage (ex.)

MARK		VOLTAGE (V)	PRODUCT SERIES
③	④		
3	3	3.3	XC62KN330xDx
5	0	5.0	XC62KN500xDx

⑤ Represents temperature characteristics

MARK	TEMPERATURE CHARACTERISTICS	PRODUCT SERIES
0	± 100 ppm (TYP.)	XC62KNxx0xDx

⑥ Represents production lot number

0 to 9, A to Z repeated (G, I, J, O, Q, W excepted)

Note: No character inversion used.



1. The products and product specifications contained herein are subject to change without notice to improve performance characteristics. Consult us, or our representatives before use, to confirm that the information in this catalog is up to date.
2. We assume no responsibility for any infringement of patents, patent rights, or other rights arising from the use of any information and circuitry in this catalog.
3. Please ensure suitable shipping controls (including fail-safe designs and aging protection) are in force for equipment employing products listed in this catalog.
4. The products in this catalog are not developed, designed, or approved for use with such equipment whose failure or malfunction can be reasonably expected to directly endanger the life of, or cause significant injury to, the user.  
(e.g. Atomic energy; aerospace; transport; combustion and associated safety equipment thereof.)
5. Please use the products listed in this catalog within the specified ranges.  
Should you wish to use the products under conditions exceeding the specifications, please consult us or our representatives.
6. We assume no responsibility for damage or loss due to abnormal use.
7. All rights reserved. No part of this catalog may be copied or reproduced without the prior permission of Torex Semiconductor Ltd.

**TOREX SEMICONDUCTOR LTD.**