

## ADJUSTABLE LOW DROPOUT REGULATOR

### FEATURES

- Low Supply Current
- Low Power Shutdown Mode
- Low Noise Output
- Low Dropout Voltage
- Extremely High Stability
- High Speed On/Off Transient (50  $\mu$ s typ.)
- Miniature Package (SOT-23L)

### APPLICATIONS

- Portable Instrumentation
- Cordless Telephones
- Pagers
- Toys
- Cellular Telephones
- Test Equipment

### DESCRIPTION

The TK11900 is a low dropout voltage regulator with external voltage adjustment. The output can be set between 1.5 V and 15 V by an external pair of resistors in a divider configuration. The device has a bypass pin for an external capacitor to reduce output noise to a typical 50  $\mu$ V(rms). In addition, a control pin is provided that is active low (a low level turns on the output). In the "off" mode (control pin high) the device draws only 65  $\mu$ A of quiescent current.

The TK11900 is available in a miniature SOT-23L surface mount package.

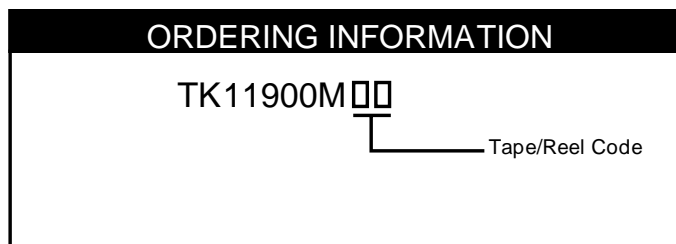
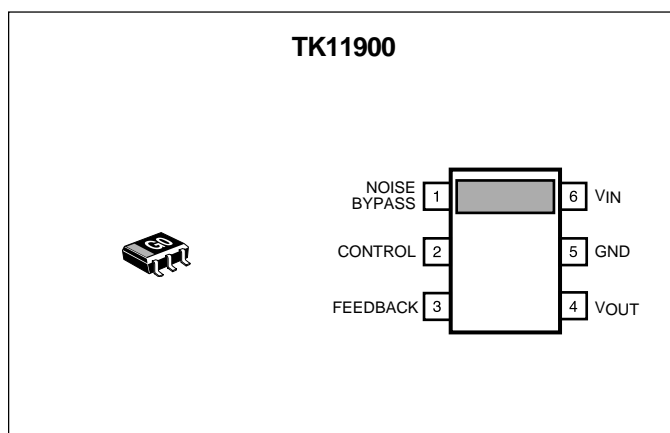

TAPE/REEL CODE  
TL: Tape Left

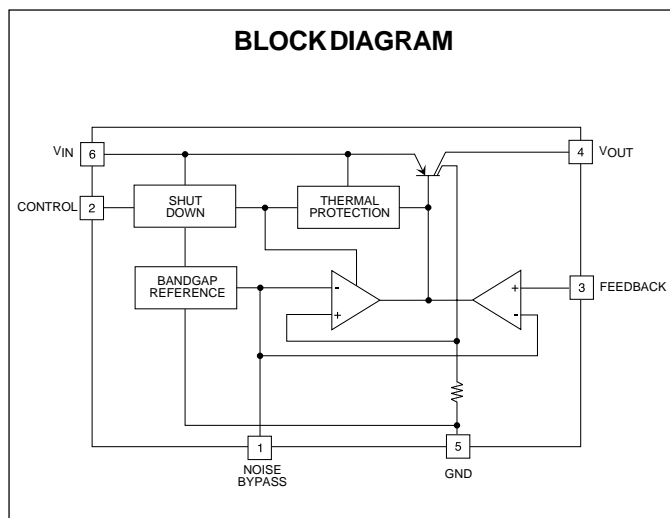

# TK11900

## ABSOLUTE MAXIMUM RATINGS

Supply Voltage .....	17 V	Operating Temperature Range .....	-30 to +80 °C
Operating Voltage Range .....	1.8 to 16 V	Junction Temperature .....	150 °C
Power Dissipation (Note 1) .....	400 mW	Lead Soldering Temperature (10 s) .....	235 °C
Storage Temperature Range .....	-55 to +150 °C		

## TK11900M ELECTRICAL CHARACTERISTICS

Test conditions:  $V_{IN} = V_{OUT(TYP)} + 1 V$ ,  $T_A = 25 °C$ , unless otherwise specified.

SYMBOL	PARAMETER	TEST CONDITIONS	MIN	TYP	MAX	UNITS
$I_Q$	Quiescent Current	$V_{IN} = V_{OUT(TYP)} + 1 V$ , $I_{OUT} = 0 mA$		140	300	$\mu A$
		$V_{IN} = V_{OUT(TYP)} - 1 V$ , $I_{OUT} = 0 mA$		380	900	$\mu A$
$I_{STBY}$	Standby Current	Output OFF		65	140	$\mu A$
$V_{OUT}$	Output Voltage	(Note 2)	1.5		15	V
$V_{DROP}$	Dropout Voltage	$I_{OUT} = 30 mA$		160	350	mV
$I_{OUT}$	Output Current				100	mA
Line Reg	Line Regulation	$V_{OUT(TYP)} + 1 V \leq V_{IN} \leq V_{OUT(TYP)} + 10 V$		5	50	mV
Load Reg	Load Regulation	$1 mA \leq I_{OUT} \leq 80 mA$		20	100	mV
$\Delta V_{OUT}/\Delta T$	Temperature Coefficient	$V_{IN} = V_{OUT(TYP)} - 1 V$		$\pm 0.15$		mV/°C
RR	Ripple Rejection	$C_L = 10 \mu F$ , $f = 400 Hz$		68		dB
$V_{NO}$	Output Noise Voltage	$10 Hz \leq f \leq 100 kHz$ , $C_L = 10 \mu F$ , $C_N = 0.01 \mu F$		50		$\mu V_{rms}$
$V_{ref}$	Reference Voltage	$T_A = 25 °C$	1.225	1.250	1.275	V
		$T_A = -30 to 80 °C$	1.210	1.250	1.290	V

### CONTROL TERMINAL SPECIFICATIONS

$I_{CONT}$	Control Terminal Current	$V_{CONT} = 5 V$		25	100	$\mu A$
		$V_{CONT} = 16 V$		45	150	$\mu A$
$V_{CONT(ON)}$	Control Voltage (ON)	Output ON			0.6	V
$V_{CONT(OFF)}$	Control Voltage (OFF)	Output OFF	2.2			V
$T_R$	Output Rise Time (OFF to ON)	$I_{OUT} = 30 mA$ , $C_L = 0.1 \mu F$ , $C_N = 0.1 \mu F$		50		$\mu s$

Note 1: Power dissipation is 400 mW when mounted as recommended. Derate at 3.2 mW/°C for operation above 25°C.

Note 2: The output voltage can be set from 1.5 to 15 V by two external resistors. "Refer to Definition of Terms."

**TEST CIRCUIT**

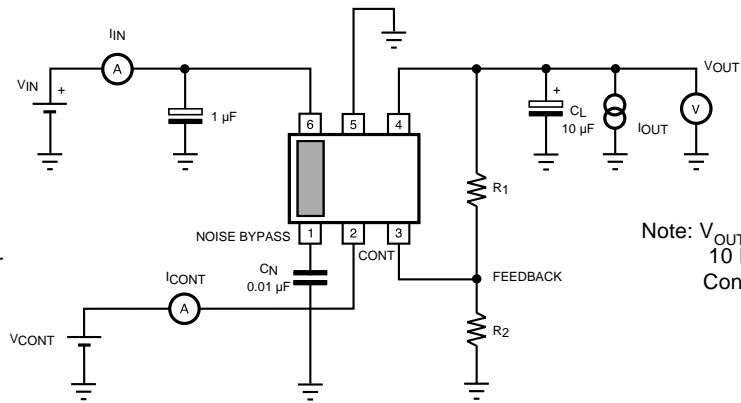

Note:  $C_L$  is a tantalum capacitor

Note:  $V_{OUT} = 1.25 [(R_1 + R_2) / R_2]$   
 $10\text{ k} - R_2 - 60\text{ k}$   
 Connect Pin 5 to ground

**TYPICAL PERFORMANCE CHARACTERISTICS**

$V_{OUT} = 5\text{ V}$ ,  $T_A = 25\text{ }^\circ\text{C}$ , unless otherwise specified.

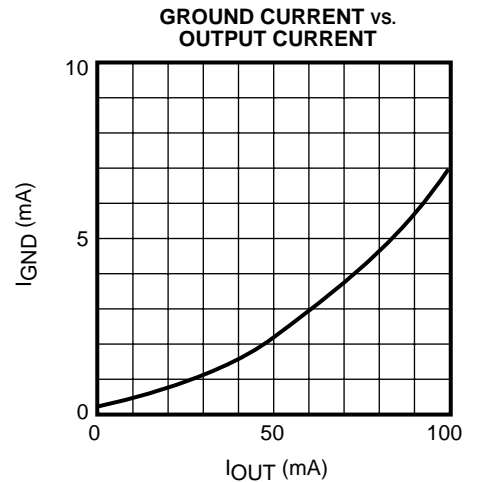
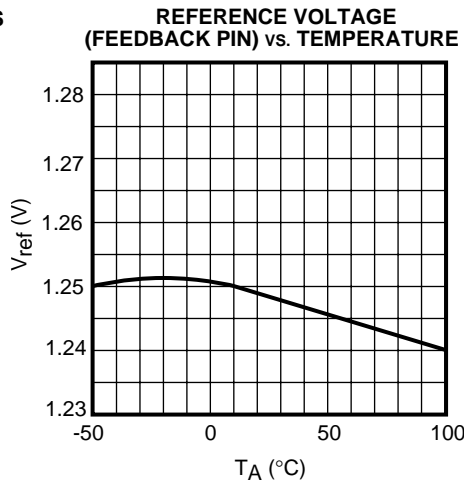
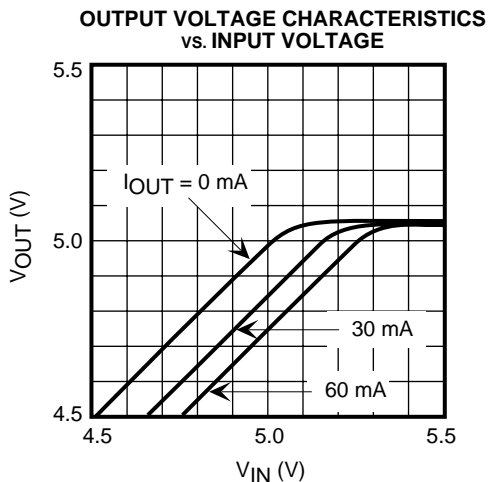
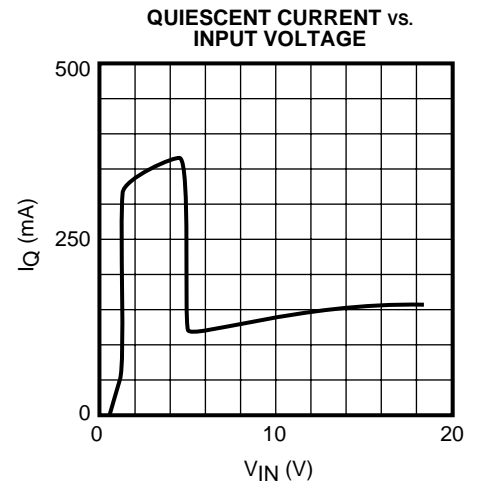
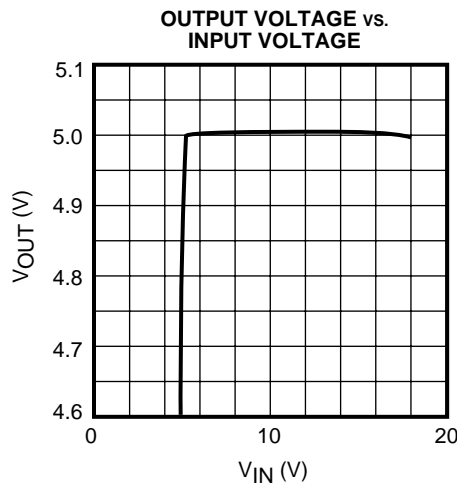
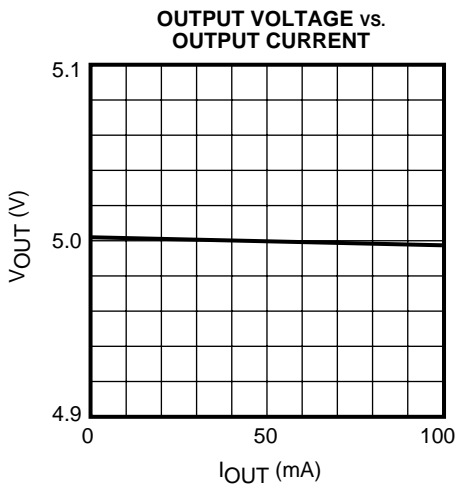

**TYPICAL PERFORMANCE CHARACTERISTICS (CONT.)**

$V_{OUT} = 5\text{ V}$ ,  $T_A = 25\text{ }^\circ\text{C}$ , unless otherwise specified.

**DROPOUT VOLTAGE vs. OUTPUT CURRENT**

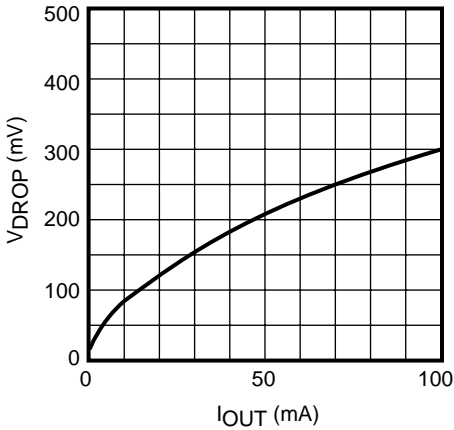

**NOISE vs. BYPASS CAPACITOR VALUE**

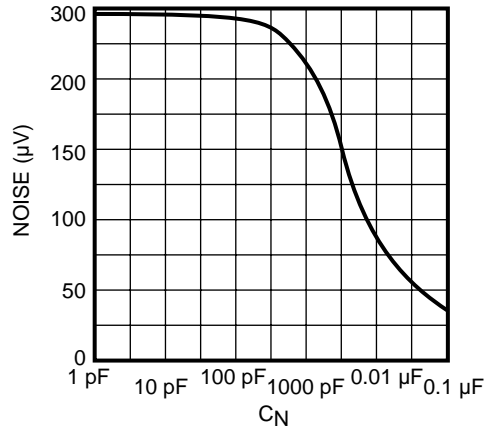

**INPUT CURRENT AND CONTROL CURRENT vs. CONTROL VOLTAGE**

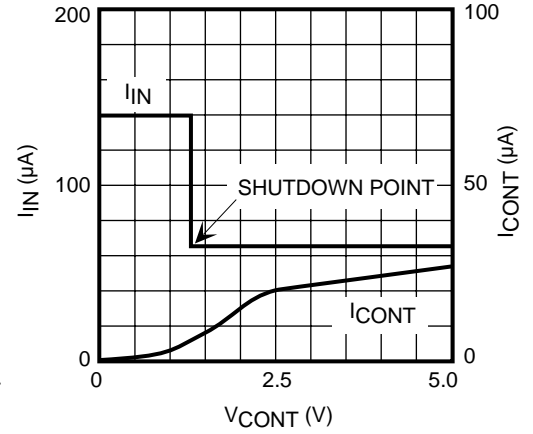

**OUTPUT VOLTAGE vs. OUTPUT CURRENT**

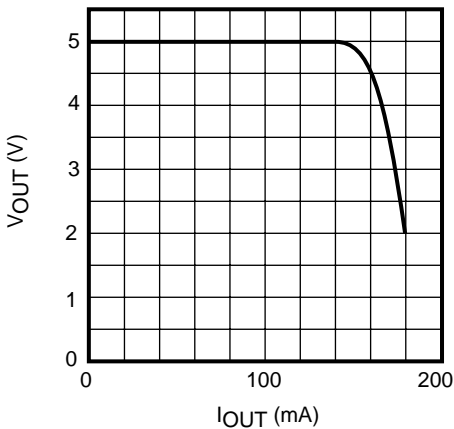

**RIPPLE REJECTION vs. FREQUENCY**

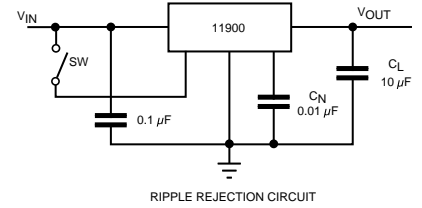
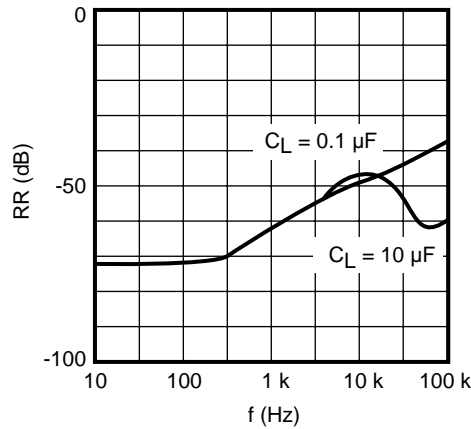

**NOISE vs. SPECTRUM**

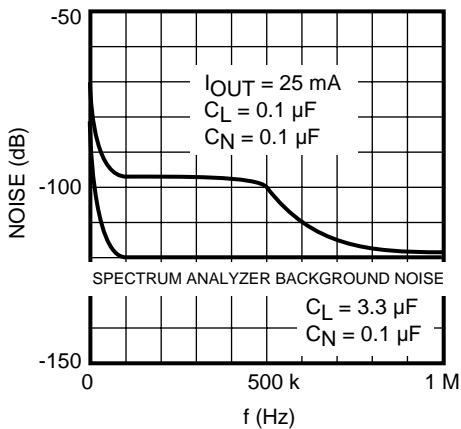

**LINE VOLTAGE STEP RESPONSE**

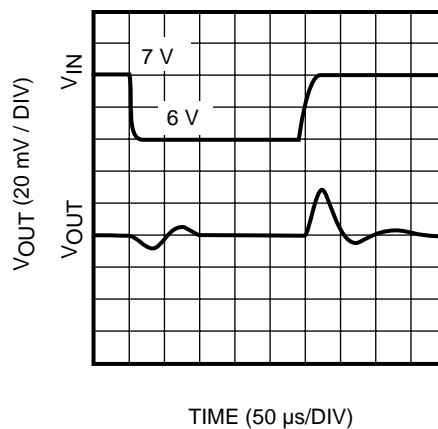

**LOAD CURRENT STEP RESPONSE**

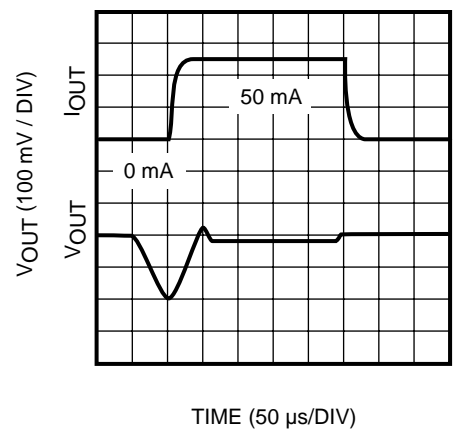

## TYPICAL PERFORMANCE CHARACTERISTICS (CONT.)

$V_{OUT} = 5\text{ V}$ ,  $T_A = 25\text{ }^\circ\text{C}$ , unless otherwise specified.

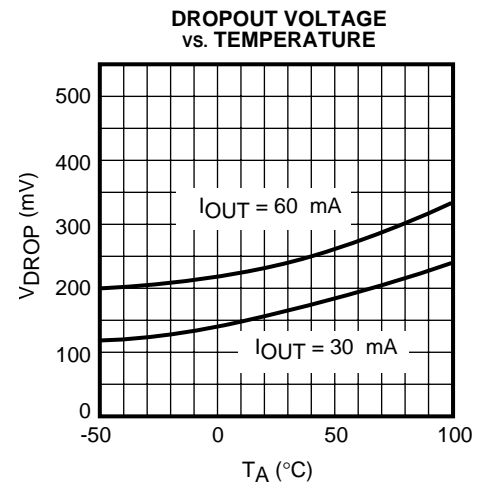
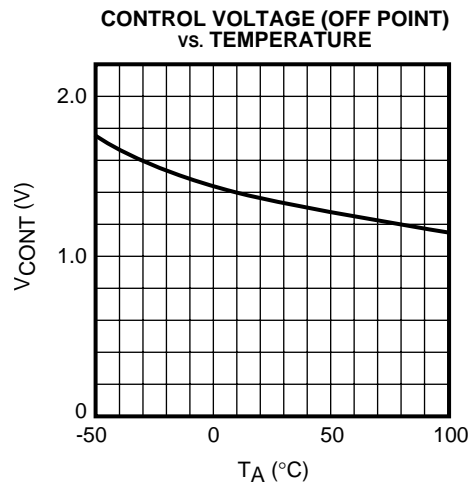
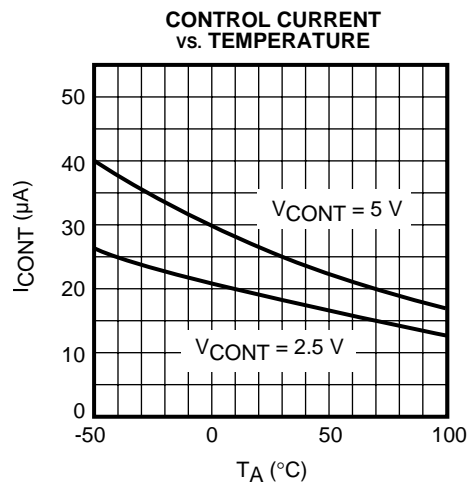
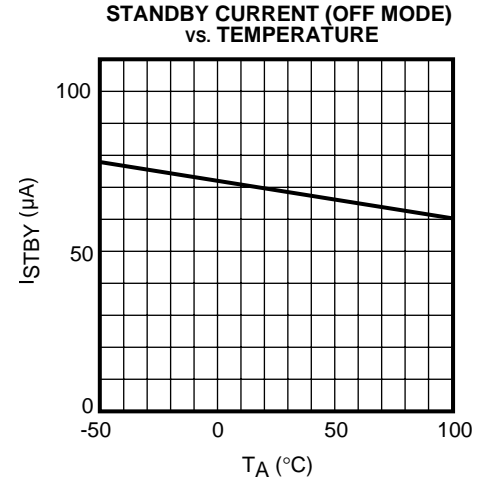
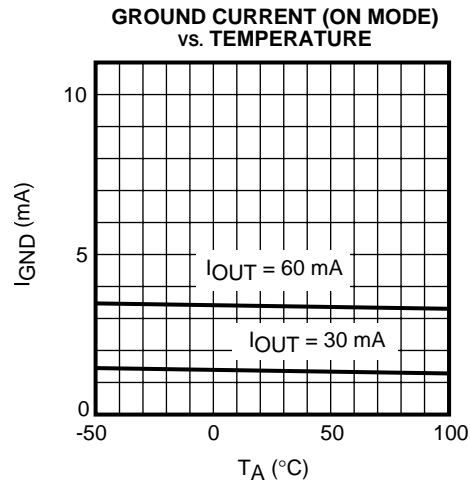
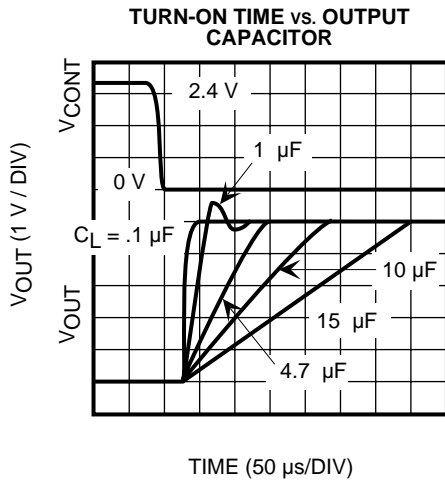

## DEFINITION AND EXPLANATION OF TECHNICAL TERMS

### QUIESCENT CURRENT ( $I_Q$ )

The quiescent current is the current which flows through the ground terminal under no load ( $I_{OUT} = 0$  mA).

### GROUND CURRENT ( $I_{GND}$ )

Ground current is the current which flows through the current pin(s). It is defined as  $I_{IN} - I_{OUT}$ , excluding control current.

### Line Regulation (Line Reg)

Line regulation is the relationship between change in output voltage due to a change in input voltage.

### Load Regulation (Load Reg)

Load regulation is the relationship between change in output voltage due to a change in load current.

### DROP OUT VOLTAGE ( $V_{DROP}$ )

This is a measure of how well the regulator performs as the input voltage decreases. The smaller the number, the further the input voltage can decrease before regulation problems occur. Nominal output voltage is first measured when  $V_{IN} = V_{OUT(TYP)} + 1$  at a chosen load current. When the output voltage has dropped 100 mV from the nominal,  $V_{IN} - V_{OUT}$  is the dropout voltage. This voltage is affected by load current and junction temperature.

### OUTPUT NOISE VOLTAGE

This is the effective AC voltage that occurs on the output voltage under the condition where the input noise is low and with a given load, filter capacitor, and frequency range.

### THERMAL PROTECTION

This is an internal feature which turns the regulator off when the junction temperature rises above 150 °C. After the regulator turns off, the temperature drops and the regulator output turns back on. Under certain conditions, the output waveform may appear to be an oscillation as the output turns off and on and back again in succession.

### PACKAGE POWER DISSIPATION ( $P_D$ )

This is the power dissipation level at which the thermal sensor is activated. The IC contains an internal thermal sensor which monitors the junction temperature. When the junction temperature exceeds the monitor threshold of 150 °C, the IC is shut down. The junction temperature rises as the difference between the input power ( $V_{IN} \times I_{IN}$ ) and the output power ( $V_{OUT} \times I_{OUT}$ ) increases. The rate of temperature rise is greatly affected by the mounting pad configuration on the PCB, the board material, and the ambient temperature. When the IC mounting has good thermal conductivity, the junction temperature will be low even if the power dissipation is great. When mounted on the recommended mounting pad, the power dissipation of the SOT-23L is increased to 400 mW. For operation at ambient temperatures over 25 °C, the power dissipation of the SOT-23L device should be derated at 3.2 mW/°C. To determine the power dissipation for shutdown when mounted, attach the device on the actual PCB and deliberately increase the output current (or raise the input voltage) until the thermal protection circuit is activated. Calculate the power dissipation of the device by subtracting the output power from the input power. These measurements should allow for the ambient temperature of the PCB. The value obtained from  $P_D / (150\text{ °C} - T_A)$  is the derating factor. The PCB mounting pad should provide maximum thermal conductivity in order to maintain low device temperatures. As a general rule, the lower the temperature, the better the reliability of the device. The thermal resistance when mounted is expressed as follows:

$$T_j = \theta_{jA} \times P_D + T_A$$

For Toko ICs, the internal limit for junction temperature is 150 °C. If the ambient temperature ( $T_A$ ) is 25 °C, then:

$$150\text{ °C} = \theta_{jA} \times P_D + 25\text{ °C}$$

$$\theta_{jA} = 125\text{ °C} / P_D$$

$P_D$  is the value when the thermal sensor is activated. A simple way to determine  $P_D$  is to calculate  $V_{IN} \times I_{IN}$  when the output side is shorted. Input current gradually falls as temperature rises. You should use the value when thermal equilibrium is reached.

## DEFINITION AND EXPLANATION OF TECHNICAL TERMS (CONT.)

The range of usable currents can also be found from the graph below.

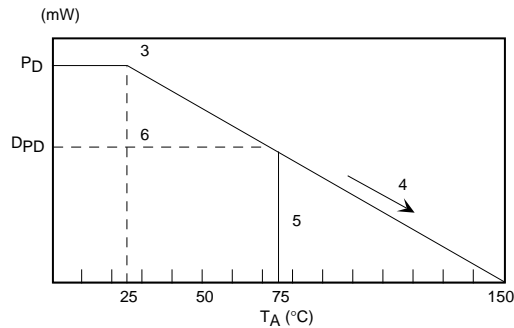

Procedure:

- 1) Find  $P_D$
- 2)  $P_{D1}$  is taken to be  $P_D \times (\sim 0.8 - 0.9)$
- 3) Plot  $P_{D1}$  against  $25^\circ\text{C}$
- 4) Connect  $P_{D1}$  to the point corresponding to the  $150^\circ\text{C}$  with a straight line.
- 5) In design, take a vertical line from the maximum operating temperature (e.g.,  $75^\circ\text{C}$ ) to the derating curve.
- 6) Read off the value of  $P_D$  against the point at which the vertical line intersects the derating curve. This is taken as the maximum power dissipation,  $D_{PD}$ .

The maximum operating current is:

$$I_{\text{OUT}} = (D_{PD} / (V_{\text{IN(MAX)}} - V_{\text{OUT}}))$$

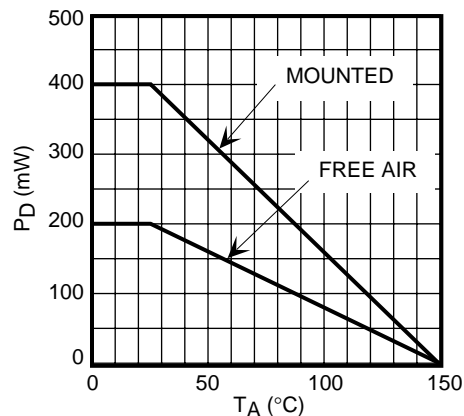

### SOT-23L POWER DISSIPATION

## APPLICATION INFORMATION

### BOARD LAYOUT

Copper pattern should be as large as possible. Power dissipation is 400 mW for the SOT-23L package. A low Equivalent Series Resistance (ESR) capacitor is recommended. For low temperature operation, select a capacitor with a low ESR at the lowest operating temperature to prevent oscillation, degradation of ripple rejection and increase in noise. The minimum recommended capacitance is 2.2  $\mu\text{F}$ .

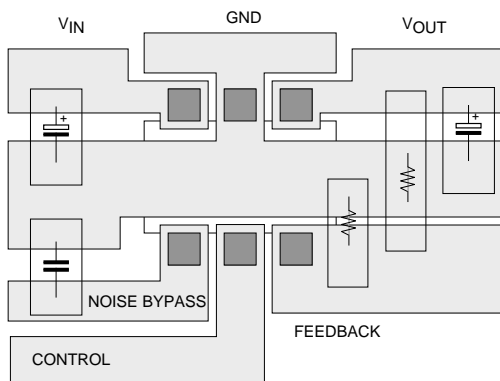

SOT-23L BOARD LAYOUT

### INPUT/OUTPUT DECOUPLING CAPACITOR CONSIDERATIONS

Voltage regulators require input and output decoupling capacitors. The required values of these capacitors vary with application. Capacitors made by different manufacturers can have different characteristics, particularly with regard to high frequencies and ESR over temperature. The type of capacitor is also important. For example, a 4.7  $\mu\text{F}$  aluminum electrolytic may be required for a certain application. If a tantalum capacitor is used, a lower value of 2.2  $\mu\text{F}$  would be adequate. It is important to consider the temperature characteristics of the decoupling capacitors. While Toko regulators are designed to operate as low as  $-30\text{ }^\circ\text{C}$ , many capacitors will not operate properly at this temperature. The capacitance of aluminum electrolytic capacitors may decrease to 0 at low temperatures. This may cause oscillation on the output of the regulator since some capacitance is required to guarantee stability. Thus, it is important

to consider the characteristics of the capacitor over temperature when selecting decoupling capacitors.

The ESR is another important parameter. The ESR will increase with temperature but low ESR capacitors are often larger and more costly. In general, tantalum capacitors offer lower ESR than aluminum electrolytic, but new low ESR aluminum electrolytic capacitors are now available from several manufacturers. Usually a bench test is sufficient to determine the minimum capacitance required for a particular application. After taking thermal characteristics and tolerance into account, the minimum capacitance value should be capacitor or 3.3  $\mu\text{F}$  for an aluminum electrolytic. Please note that linear regulators with a low dropout voltage have high internal loop gains which require care in guarding against oscillation caused by insufficient decoupling capacitance. The use of high quality decoupling capacitors suited for your application will guarantee proper operation of the circuit.

### NOISE BYPASS CAPACITOR SECTION

The noise bypass capacitor ( $C_N$ ) should be connected as close as possible to pin 1 and ground. The recommended value for  $C_N$  is 0.01 mF. The noise bypass terminal has a high impedance and care should be taken if the noise bypass capacitor is not used. This terminal is susceptible to external noise, and oscillation can occur when  $C_N$  is not used and the solder pad for this pin is too large.

### OUTPUT VOLTAGE SETTING

The output voltage can be set from 1.5 to 15 V by two external resistors according to the following equation:

$$V_{\text{OUT}} = 1.25 \text{ V} \times [(R_1 + R_2) / R_2]$$

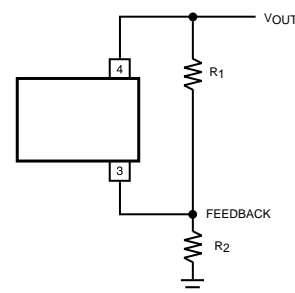

where  $10 \text{ k}\Omega - R_2 - 60 \text{ k}$



## APPLICATION INFORMATION (CONT.)

## CURRENT BOOST

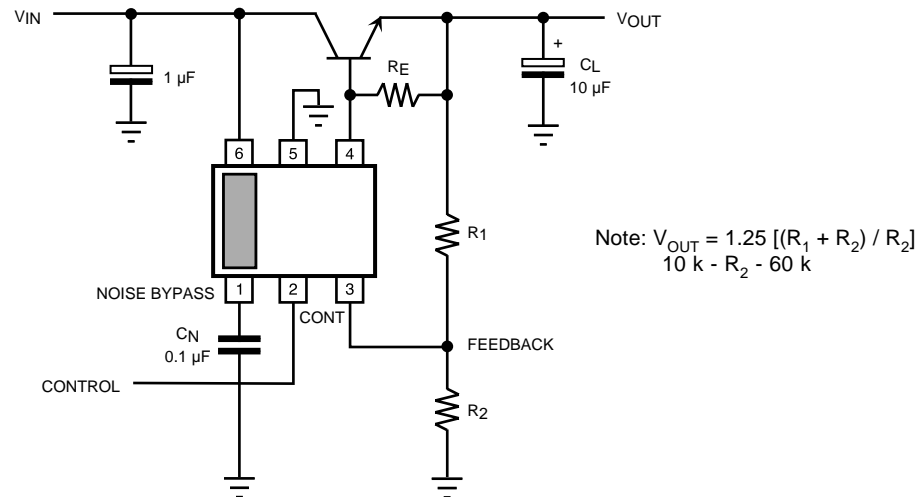

The output current can be increased by connecting an external NPN transistor as shown above.

The output current capability depends on the  $H_{fe}$  of the external transistor.

Note: The TK11900 internal short circuit protection and the thermal sensor do not protect the external transistor.

PACKAGE OUTLINE

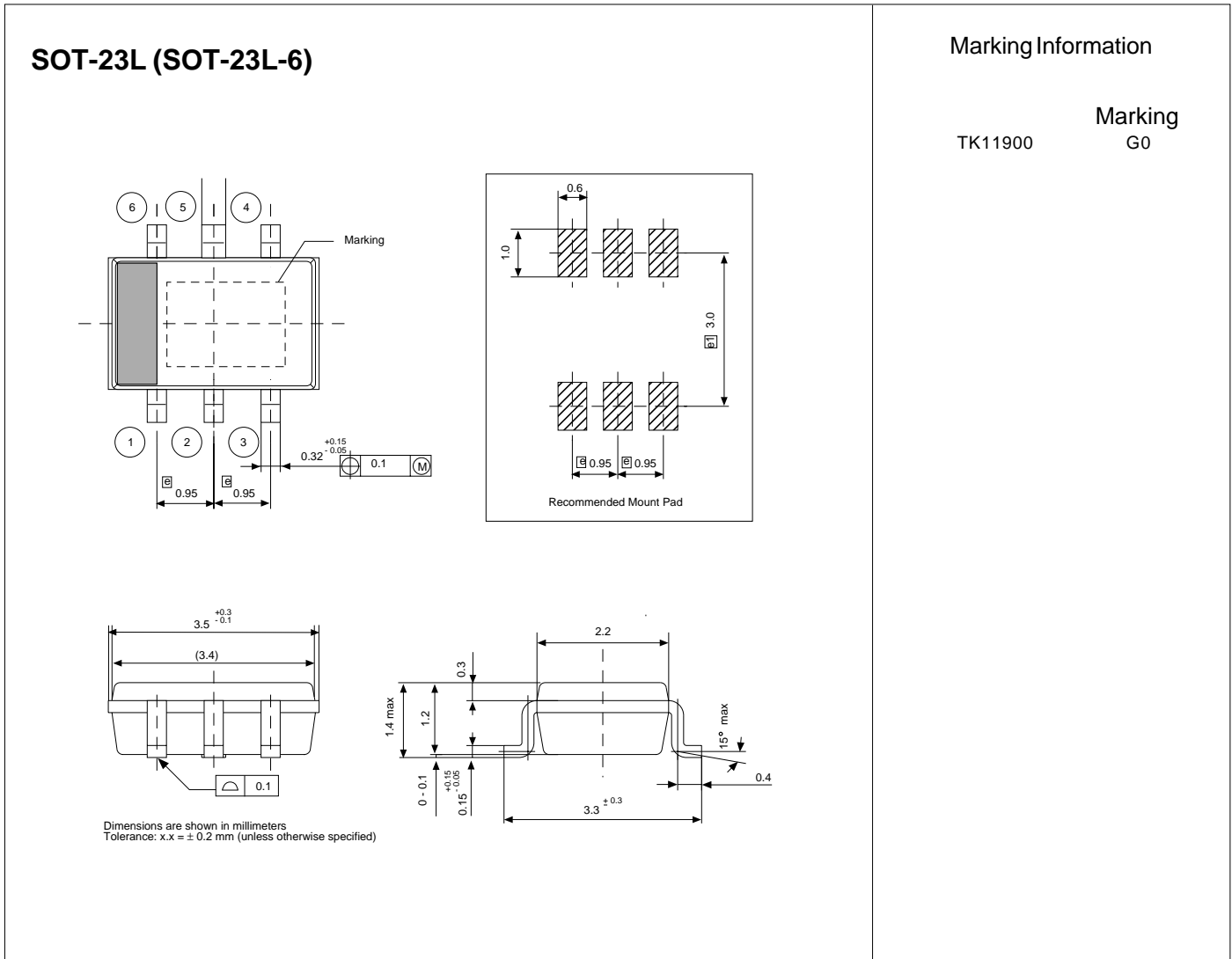

Toko America, Inc. Headquarters  
1250 Feehanville Drive, Mount Prospect, Illinois 60056  
Tel: (847) 297-0070 Fax: (847) 699-7864

TOKO AMERICA REGIONAL OFFICES

Midwest Regional Office  
Toko America, Inc.  
1250 Feehanville Drive  
Mount Prospect, IL 60056  
Tel: (847) 297-0070  
Fax: (847) 699-7864

Western Regional Office  
Toko America, Inc.  
2480 North First Street, Suite 260  
San Jose, CA 95131  
Tel: (408) 432-8281  
Fax: (408) 943-9790

Semiconductor Technical Support  
Toko Design Center  
4755 Forge Road  
Colorado Springs, CO 80907  
Tel: (719) 528-2200  
Fax: (719) 528-2375

Visit our Internet site at <http://www.tokoam.com>

The information furnished by TOKO, Inc. is believed to be accurate and reliable. However, TOKO reserves the right to make changes or improvements in the design, specification or manufacture of its products without further notice. TOKO does not assume any liability arising from the application or use of any product or circuit described herein, nor for any infringements of patents or other rights of third parties which may result from the use of its products. No license is granted by implication or otherwise under any patent or patent rights of TOKO, Inc.