

TOSHIBA Transistor Silicon NPN Epitaxial Type (PCT Process)

RN1961, RN1962, RN1963 RN1964, RN1965, RN1966

Switching, Inverter Circuit, Interface Circuit
And Driver Circuit Applications

- Including two devices in US6 (ultra super mini type 6 leads)
- With built-in bias resistors
- Simplify circuit design
- Reduce a quantity of parts and manufacturing process
 - Complementary to RN2961~RN2966

Equivalent Circuit and Bias Resistor Values

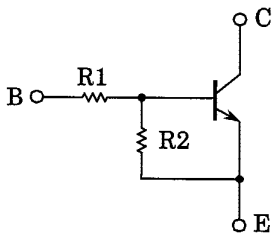

Type No.	R1 (kΩ)	R2 (kΩ)
RN1961	4.7	4.7
RN1962	10	10
RN1963	22	22
RN1964	47	47
RN1965	2.2	47
RN1966	4.7	47

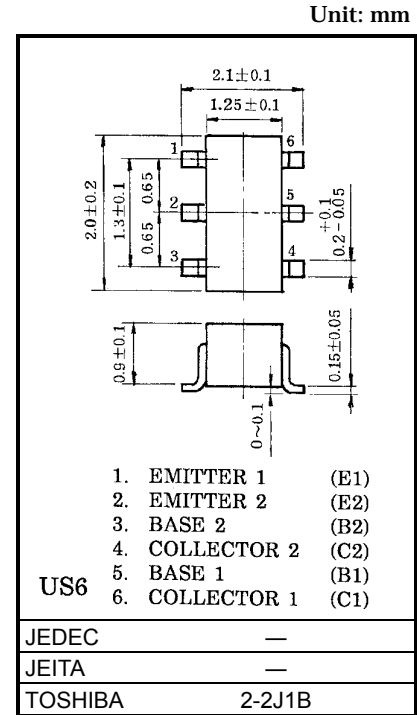

Maximum Ratings (Ta = 25°C) (Q1, Q2 Common)

Characteristic	Symbol	Rating	Unit
Collector-base voltage	RN1961~1966	V_{CBO}	50
Collector-emitter voltage		V_{CEO}	50
Emitter-base voltage	RN1961~1964	V_{EBO}	10
	RN1965, 1966		5
Collector current	RN1961~1966	I_C	100
Collector power dissipation		P_C^*	200
Junction temperature		T_j	150
Storage temperature range		T_{stg}	-55~150

*: Total rating

Equivalent Circuit (Top View)

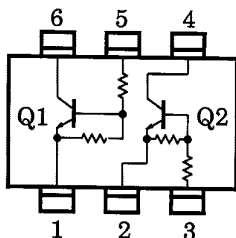

Electrical Characteristics (Ta = 25°C) (Q1, Q2 Common)

Characteristic		Symbol	Test Circuit	Test Condition	Min	Typ.	Max	Unit
Collector cut-off current	RN1961~1966	I_{CBO}	—	$V_{CB} = 50V, I_E = 0$	—	—	100	nA
		I_{CEO}	—	$V_{CE} = 50V, I_B = 0$	—	—	500	
Emitter cut-off current	RN1961	I_{EBO}	—	$V_{EB} = 10V, I_C = 0$	0.82	—	1.52	mA
	RN1962		—		0.38	—	0.71	
	RN1963		—		0.17	—	0.33	
	RN1964		—	0.082	—	0.15		
	RN1965		—	$V_{EB} = 5V, I_C = 0$	0.078	—	0.145	
	RN1966		—		0.074	—	0.138	
DC current gain	RN1961	h_{FE}	—	$V_{CE} = 5V, I_C = 10mA$	30	—	—	—
	RN1962		—		50	—	—	
	RN1963		—		70	—	—	
	RN1964		—		80	—	—	
	RN1965		—		80	—	—	
	RN1966		—		80	—	—	
Collector-emitter saturation voltage	RN1961~1966	$V_{CE(sat)}$	—	$I_C = 5mA, I_B = 0.25mA$	—	0.1	0.3	V
Input voltage (ON)	RN1961	$V_I(ON)$	—	$V_{CE} = 0.2V, I_C = 5mA$	1.1	—	2.0	V
	RN1962		—		1.2	—	2.4	
	RN1963		—		1.3	—	3.0	
	RN1964		—		1.5	—	5.0	
	RN1965		—		0.6	—	1.1	
	RN1966		—		0.7	—	1.3	
Input voltage (OFF)	RN1961~1964	$V_I(OFF)$	—	$V_{CE} = 5V, I_C = 0.1mA$	1.0	—	1.5	V
	RN1965, 1966		—		0.5	—	0.8	
Translation frequency	RN1961~1966	f_T	—	$V_{CE} = 10V, I_C = 5mA$	—	250	—	MHz
Collector output capacitance	RN1961~1966	C_{ob}	—	$V_{CB} = 10V, I_E = 0, f = 1MHz$	—	3	6	pF
Input resistor	RN1961	R1	—	—	3.29	4.7	6.11	kΩ
	RN1962		—		7	10	13	
	RN1963		—		15.4	22	28.6	
	RN1964		—		32.9	47	61.1	
	RN1965		—		1.54	2.2	2.86	
	RN1966		—		3.29	4.7	6.11	
Resistor ratio	RN1961~1965	R1/R2	—	—	0.9	1.0	1.1	—
	RN1965		—		0.0421	0.0468	0.0515	
	RN1966		—		0.09	0.1	0.11	

(Q1, Q2 Common)

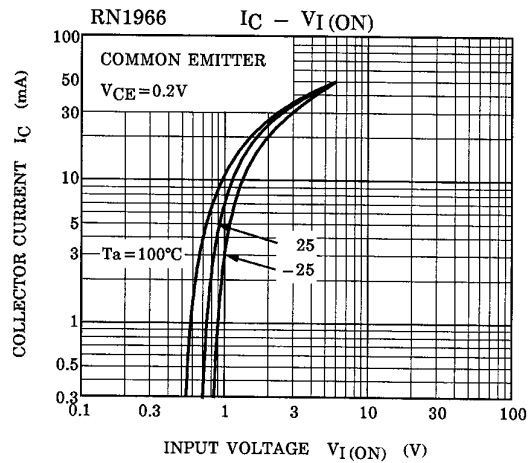
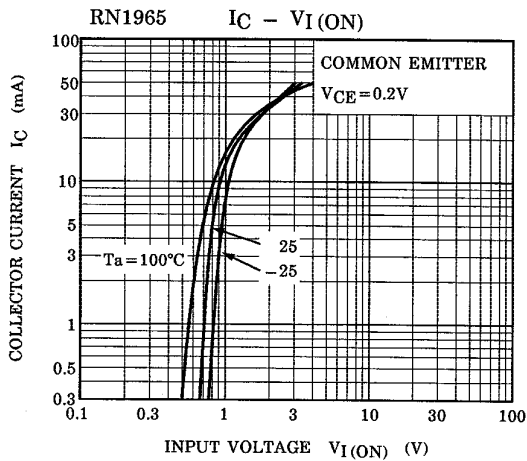
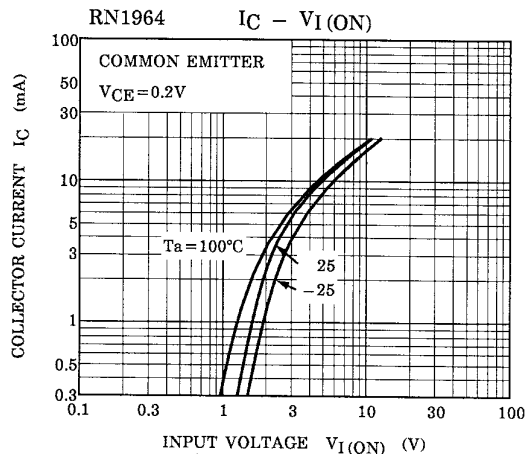
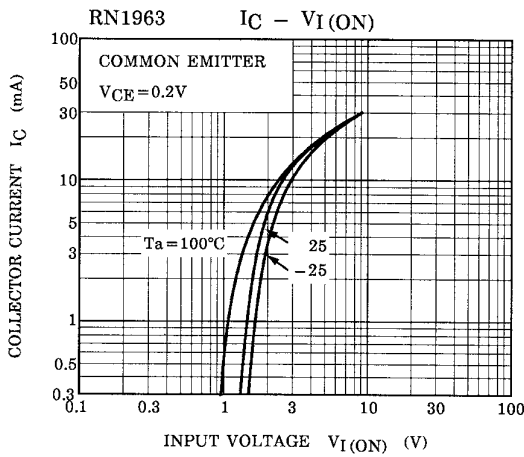
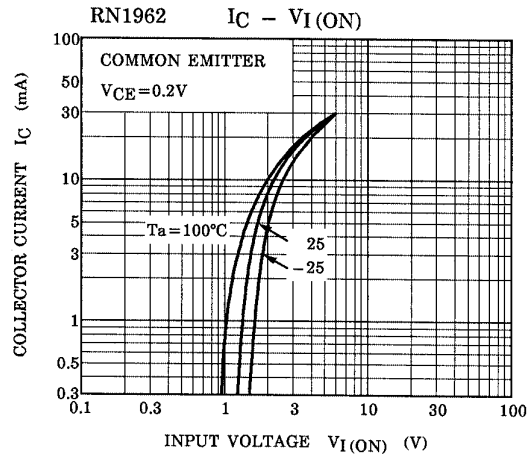
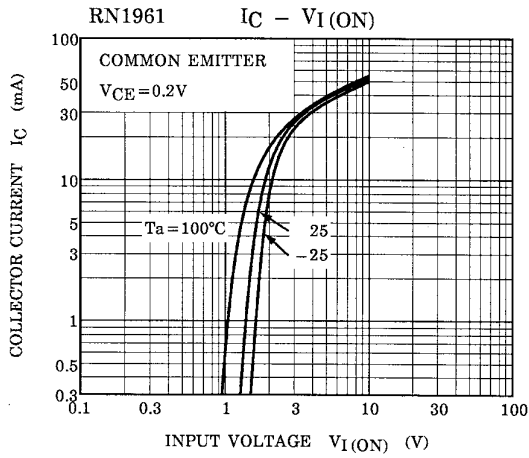

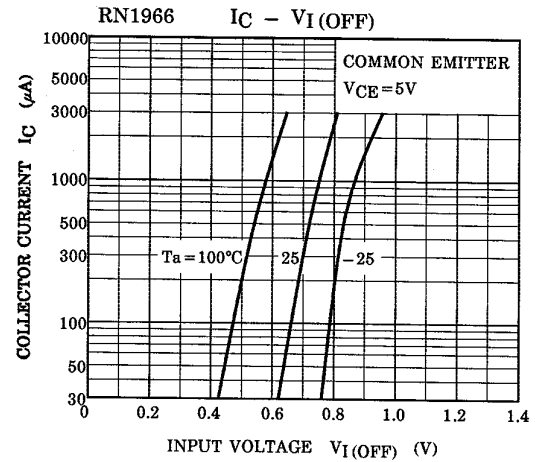
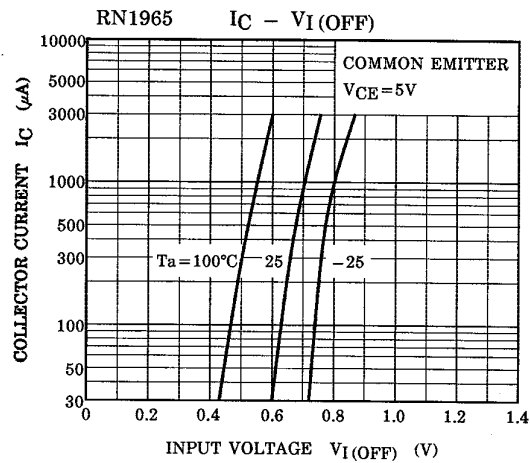
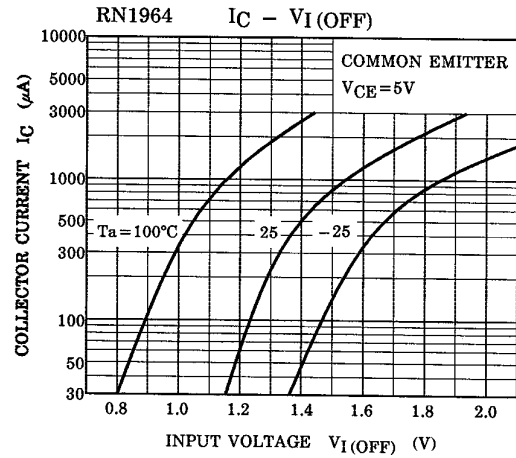
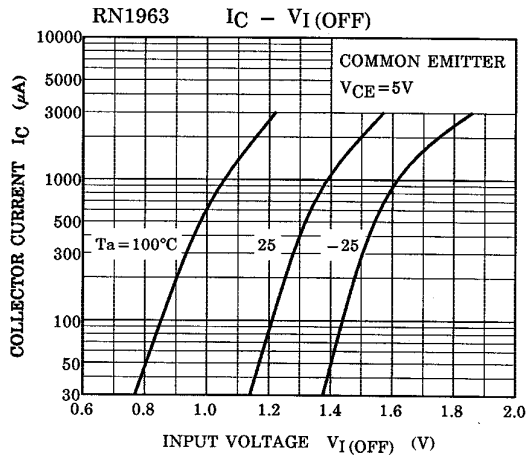
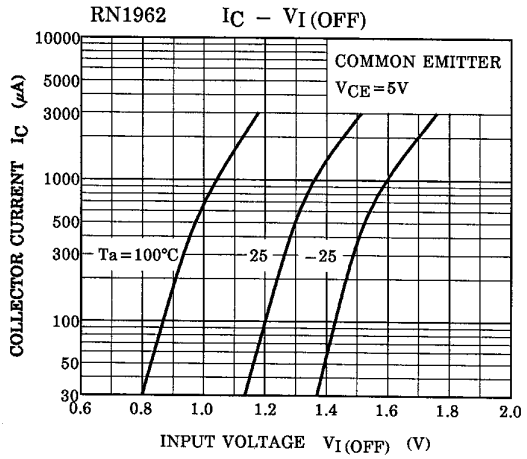
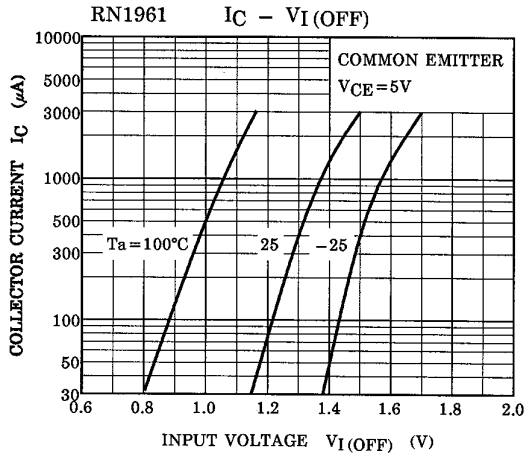

(Q1, Q2 Common)

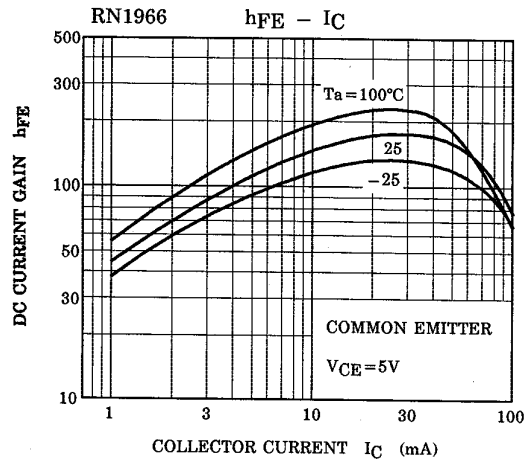
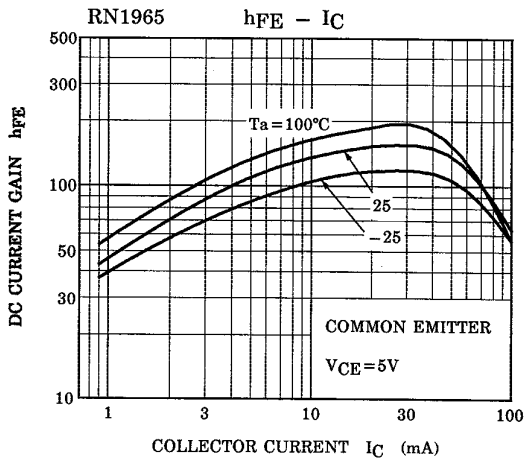
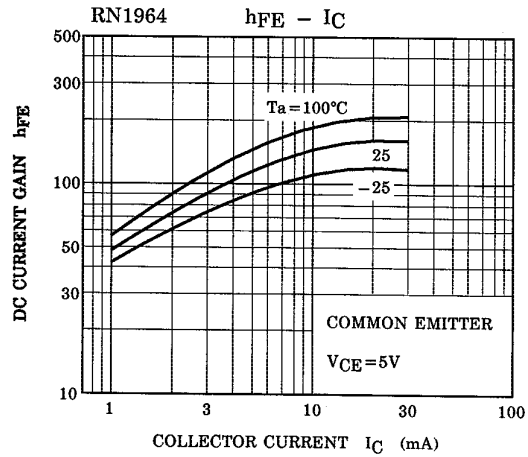
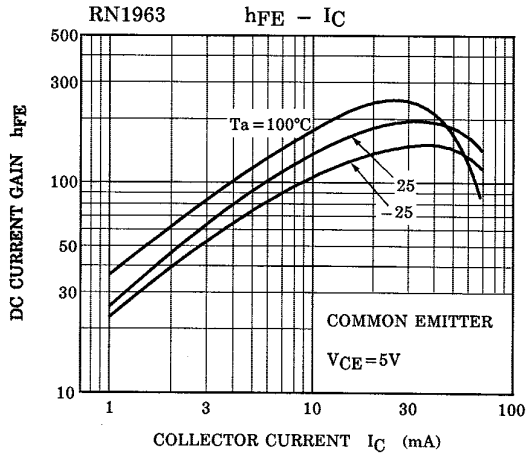
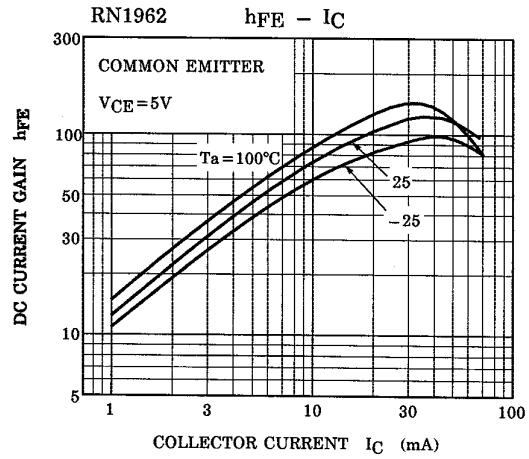
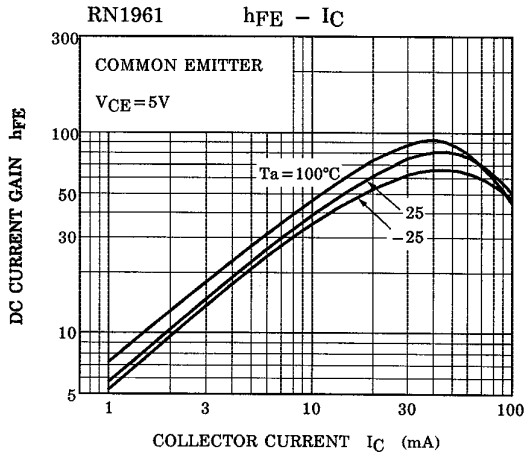

(Q1, Q2 Common)

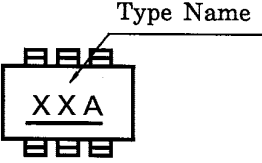
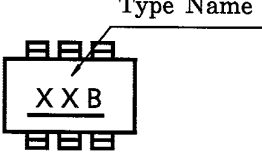
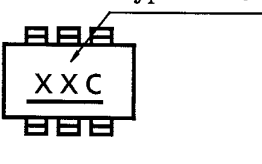
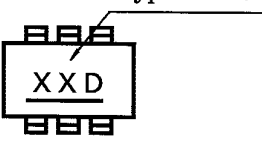
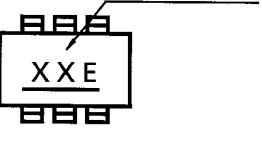

Type Name	Marking
RN1961	
RN1962	
RN1963	
RN1964	
RN1965	
RN1966	

RESTRICTIONS ON PRODUCT USE

030619EAA

- The information contained herein is subject to change without notice.
- The information contained herein is presented only as a guide for the applications of our products. No responsibility is assumed by TOSHIBA for any infringements of patents or other rights of the third parties which may result from its use. No license is granted by implication or otherwise under any patent or patent rights of TOSHIBA or others.
- TOSHIBA is continually working to improve the quality and reliability of its products. Nevertheless, semiconductor devices in general can malfunction or fail due to their inherent electrical sensitivity and vulnerability to physical stress. It is the responsibility of the buyer, when utilizing TOSHIBA products, to comply with the standards of safety in making a safe design for the entire system, and to avoid situations in which a malfunction or failure of such TOSHIBA products could cause loss of human life, bodily injury or damage to property.
In developing your designs, please ensure that TOSHIBA products are used within specified operating ranges as set forth in the most recent TOSHIBA products specifications. Also, please keep in mind the precautions and conditions set forth in the "Handling Guide for Semiconductor Devices," or "TOSHIBA Semiconductor Reliability Handbook" etc..
- The TOSHIBA products listed in this document are intended for usage in general electronics applications (computer, personal equipment, office equipment, measuring equipment, industrial robotics, domestic appliances, etc.). These TOSHIBA products are neither intended nor warranted for usage in equipment that requires extraordinarily high quality and/or reliability or a malfunction or failure of which may cause loss of human life or bodily injury ("Unintended Usage"). Unintended Usage include atomic energy control instruments, airplane or spaceship instruments, transportation instruments, traffic signal instruments, combustion control instruments, medical instruments, all types of safety devices, etc.. Unintended Usage of TOSHIBA products listed in this document shall be made at the customer's own risk.
- TOSHIBA products should not be embedded to the downstream products which are prohibited to be produced and sold, under any law and regulations.