

OUTLINE

R3130N/R3131N Series are CMOS-based low voltage detector ICs with built-in delay circuit, high Detector Threshold accuracy and ultra low supply current which can be operated at low voltage.

These ICs can be used as system reset generator, and each of these ICs consists of a voltage reference, a comparator, resistors for setting voltage detector threshold, an output driver transistor, and an output delay generator.

Detector threshold is fixed internally with high accuracy and requires no adjustment. When Supply Voltage crosses a setting detector threshold voltage from a high value to a lower value, this IC generates reset signal.

R3130N Series output "L" at detection mode, while R3131N Series output "H".

Further, each of R3130N/R3131N Series embeds an output delay generator, when Supply Voltage crosses a setting detector threshold voltage from a low value to a higher value, during a setting delay time which is fixed in the IC, this IC keeps the reset condition.

Output Delay Time can be selected. (Typ. 240ms is standard.)

Two output types, Nch open drain type and CMOS type, are available.

Since the package for these ICs is SOT23-3 (Mini-mold) package, high density mounting of the ICs on board is possible.

FEATURES

- Pin to Pin compatible with MAX 809/810 (R3130Nxxxx: MAX 809, R3131Nxxxx: MAX 810)
- Ultra-low supply Current Typ. 1.25 μ A (R313xN27xx: $V_{DD}=3.0V$)
- Operating Voltage Range 1.0V to 6.0V ($T_{opt}=25^{\circ}C$)
- Detector Threshold Setting with a step of 0.1V in the range of 1.6V to 4.8V is possible.
- Embedded Power on Reset Delay Time Circuit Delay Time can be designated. Refer to Selection Guide.
- High Accuracy Detector Threshold $\pm 1.5\%$
- High Accuracy Output Delay Time $\pm 10.0\%$
- Low Temperature-Drift Coefficient of Detector Threshold .. Typ. $\pm 100ppm/^{\circ}C$
- Two Output Types Nch Open Drain and CMOS
- Small Package SOT-23-3

APPLICATIONS

- CPU & Logic Circuit Reset
- Battery Checker
- Window Comparator
- Wave Shaping Circuit
- Battery Back-Up Circuit
- Power Failure Detector

BLOCK DIAGRAMS

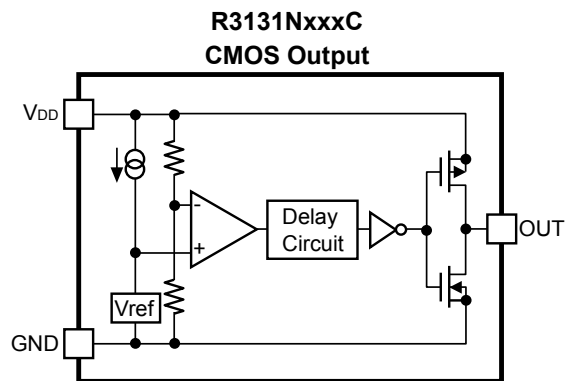
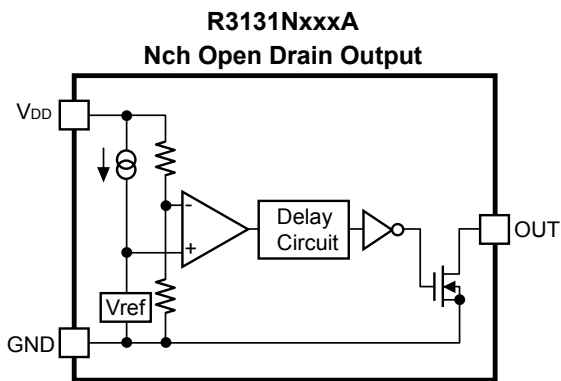
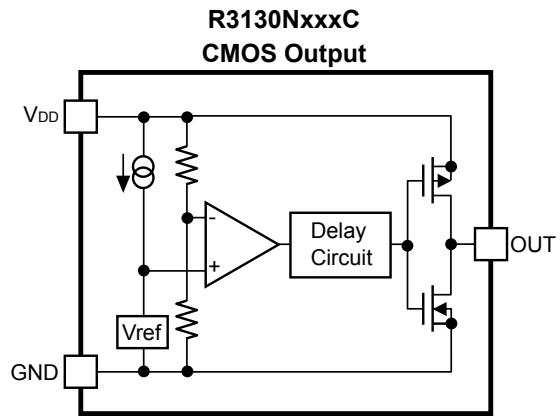
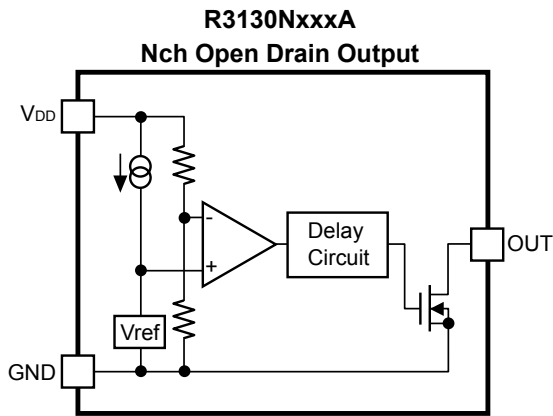

TIMING CHART

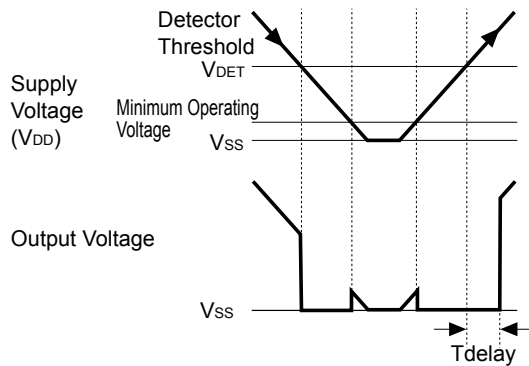

R3130N Operation Diagram

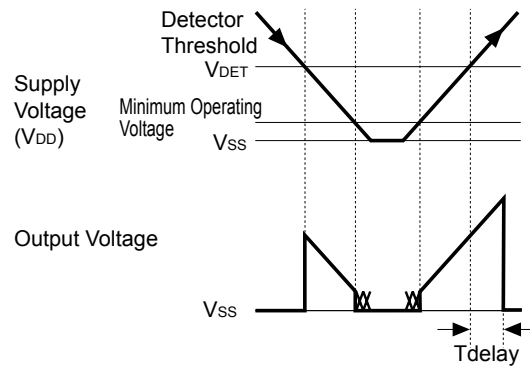

R3131N Operation Diagram

• Output Delay Operation

Output Delay Time, or T_{delay} is specified as follows:

1. In the case of Nch open drain output:

The time interval from rising edge of V_{DD} pulse ($1.0V \rightarrow (V_{DET}+1.0V)$) to the time at which the output reaches $2.5V$ under the condition that the output pin (OUT) is pulled up to $5V$ through a $470k\Omega$ resistor.

2. In the case of CMOS output

The time interval from rising edge of V_{DD} pulse ($1.0V \rightarrow (V_{DET}+1.0V)$) to the time at which the output reaches $V_{DD}/2$.

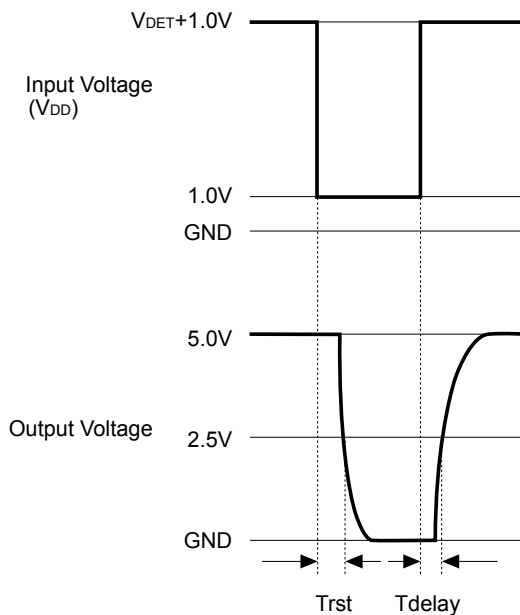

Nch Open Drain Output

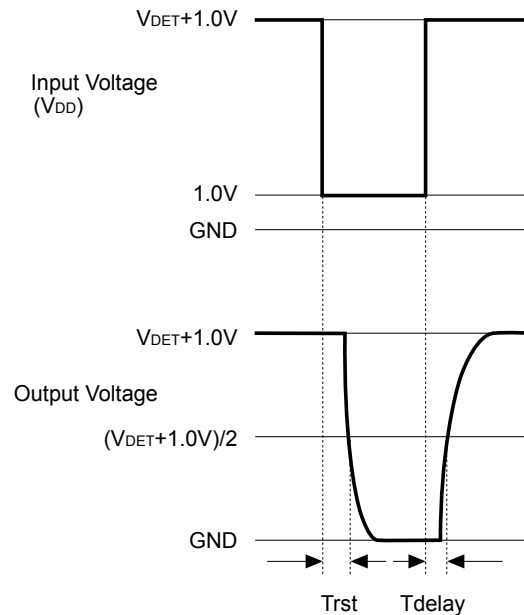

CMOS Output

SELECTION GUIDE

The detector threshold, the output type, and Output delay time of R3130N/R3131N series can be designated at the user's request by specifying the part number as follows:

R3130Nxxxx(x)-TR ←Part Number
 R3131Nxxxx(x)-TR ←Part Number
 ↑↑↑↑ ↑
 a b c d e

Code	Contents
a	Setting Detector Threshold (V_{DET}) Stepwise setting with a step of 0.1V in the range of 1.6V to 4.8V is possible. The following 4 kinds of voltage are also standard. 2.63V, 2.93V, 3.08V, 4.65V
b	Selection of Output Delay Time E: 240ms (Standard) A: 50ms B: 100ms D: 200ms H: 400ms *A, B, D, H versions can be produced only for 6 kinds of standard voltage items.
c	Designation Output type A: Nch Open Drain C: CMOS
d	Description of last one digit of 4 kinds of standard voltage items.
e	Designation of Taping Direction (Refer to Taping Specification)

PIN CONFIGURATION

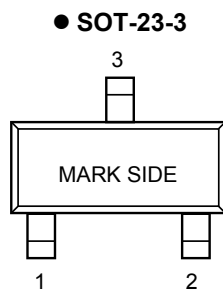

PIN DESCRIPTION

Pin No	Symbol	Description
1	GND	Ground Pin
2	OUT	Output Pin R3130N: Output "L" at detection mode, Output "H" at release mode R3131N: Output "H" at detection mode, Output "L" at release mode
3	V_{DD}	Input Pin

ABSOLUTE MAXIMUM RATINGS

Symbol	Item	Rating	Unit	
V_{DD}	Supply Voltage	6.5	V	
V_{OUT}	Output Voltage	CMOS	$V_{SS}-0.3$ to $V_{DD}+0.3$	V
		Nch	$V_{SS}-0.3$ to 6.5	V
I_{OUT}	Output Current	20	mA	
P_D	Power Dissipation	150	mW	
T_{opt}	Operating Temperature Range	-40 to +85	°C	
T_{stg}	Storage Temperature Range	-55 to +125	°C	
T_{solder}	Soldering Temperature	260°C, 10s		

ABSOLUTE MAXIMUM RATINGS

Absolute Maximum Ratings are threshold limit values that must not be exceeded even for a moment under any conditions.

Moreover, such values for any items must not be reached simultaneously. Operation above these absolute maximum ratings may cause degradation or permanent damage to the device. These are just stress ratings and do not necessarily imply to guarantee operation below these limits.

ELECTRICAL CHARACTERISTICS

• R3130N26xx3-TR

[$T_{opt}=25^{\circ}\text{C}$]

Symbol	Item	Conditions	Min.	Typ.	Max.	Unit
V_{DDH}	Maximum Operating Voltage				6.0	V
V_{DDL}^{*1}	Minimum Operating Voltage	$I_{OL}=50\mu\text{A}$		0.75	1.00	V
V_{DET}	Detector Threshold		2.591	2.630	2.669	V
I_{SS1}	Supply Current1	$V_{DD}=6.00\text{V}$		1.40	5.00	μA
I_{SS2}	Supply Current2	$V_{DD}=2.73\text{V}$		1.25	4.00	μA
I_{SS3}	Supply Current3	$V_{DD}=2.53\text{V}$		1.10	3.50	μA
V_{OH}	"H" Output Voltage	$V_{DD}=2.73\text{V}$, $I_{OUT}=-500\mu\text{A}$	$0.8 \times V_{DD}$	$0.93 \times V_{DD}$		V
V_{OL}	"L" Output Voltage	$V_{DD}=2.53\text{V}$, $I_{OUT}=1.2\text{Ma}$		0.16	0.30	V
T_{delay}^{*2}	Output Delay Time for release	Refer to electrical characteristics by Output Delay Time for release				
$\frac{\Delta V_{DET}}{\Delta T_{opt}}$	Detector Threshold Temperature Coefficient	$-40^{\circ}\text{C} \leq T_{opt} \leq 85^{\circ}\text{C}$		± 100		ppm/°C

R3130N/R3131N

• R3130N29xx3-TR

[Topt=25°C]

Symbol	Item	Conditions	Min.	Typ.	Max.	Unit
V _{DDH}	Maximum Operating Voltage				6.0	V
V _{DDL} *1	Minimum Operating Voltage	I _{OL} =50μA		0.75	1.00	V
V _{DET}	Detector Threshold		2.887	2.930	2.973	V
I _{SS1}	Supply Current1	V _{DD} =6.00V		1.40	5.00	μA
I _{SS2}	Supply Current2	V _{DD} =3.03V		1.25	4.00	μA
I _{SS3}	Supply Current3	V _{DD} =2.83V		1.10	3.50	μA
V _{OH}	“H” Output Voltage	V _{DD} =3.03V, I _{OUT} =-500μA	0.8×V _{DD}	0.93×V _{DD}		V
V _{OL}	“L” Output Voltage	V _{DD} =2.83V, I _{OUT} =1.2mA		0.16	0.30	V
T _{delay} *2	Output Delay Time for release	Refer to electrical characteristics by Output Delay Time for release				
ΔV _{DET} / ΔT _{opt}	Detector Threshold Temperature Coefficient	-40°C ≤ T _{opt} ≤ 85°C		±100		ppm/°C

• R3130N30xx8-TR

[Topt=25°C]

Symbol	Item	Conditions	Min.	Typ.	Max.	Unit
V _{DDH}	Maximum Operating Voltage				6.0	V
V _{DDL} *1	Minimum Operating Voltage	I _{OL} =50μA		0.75	1.00	V
V _{DET}	Detector Threshold		3.034	3.080	3.126	V
I _{SS1}	Supply Current1	V _{DD} =6.00V		1.40	5.00	μA
I _{SS2}	Supply Current2	V _{DD} =3.18V		1.25	4.00	μA
I _{SS3}	Supply Current3	V _{DD} =2.98V		1.10	3.50	μA
V _{OH}	“H” Output Voltage	V _{DD} =3.18V, I _{OUT} =-500μA	0.8×V _{DD}	0.93×V _{DD}		V
V _{OL}	“L” Output Voltage	V _{DD} =2.98V, I _{OUT} =1.2mA		0.16	0.30	V
T _{delay} *2	Output Delay Time for release	Refer to electrical characteristics by Output Delay Time for release				
ΔV _{DET} / ΔT _{opt}	Detector Threshold Temperature Coefficient	-40°C ≤ T _{opt} ≤ 85°C		±100		ppm/°C

- R3130N40xx-TR

[Topt=25°C]

Symbol	Item	Conditions	Min.	Typ.	Max.	Unit
V _{DDH}	Maximum Operating Voltage				6.0	V
V _{DDL} *1	Minimum Operating Voltage	I _{OL} =50μA		0.75	1.00	V
V _{DET}	Detector Threshold		3.940	4.000	4.060	V
I _{SS1}	Supply Current1	V _{DD} =6.00V		1.40	5.00	μA
I _{SS2}	Supply Current2	V _{DD} =4.10V		1.30	4.00	μA
I _{SS3}	Supply Current3	V _{DD} =3.90V		1.15	3.50	μA
V _{OH}	“H” Output Voltage	V _{DD} =4.10V, I _{OUT} =-800μA	0.8×V _{DD}	0.95×V _{DD}		V
V _{OL}	“L” Output Voltage	V _{DD} =3.90V, I _{OUT} =3.2mA		0.18	0.40	V
T _{delay} *2	Output Delay Time for release	Refer to electrical characteristics by Output Delay Time for release				
$\frac{\Delta V_{DET}}{\Delta T_{opt}}$	Detector Threshold Temperature Coefficient	-40°C ≤ T _{opt} ≤ 85°C		±100		ppm/°C

- R3130N44xx-TR

[Topt=25°C]

Symbol	Item	Conditions	Min.	Typ.	Max.	Unit
V _{DDH}	Maximum Operating Voltage				6.0	V
V _{DDL} *1	Minimum Operating Voltage	I _{OL} =50μA		0.75	1.00	V
V _{DET}	Detector Threshold		4.334	4.400	4.466	V
I _{SS1}	Supply Current1	V _{DD} =6.00V		1.40	5.00	μA
I _{SS2}	Supply Current2	V _{DD} =4.50V		1.30	4.00	μA
I _{SS3}	Supply Current3	V _{DD} =4.30V		1.15	3.50	μA
V _{OH}	“H” Output Voltage	V _{DD} =4.50V, I _{OUT} =-800μA	0.8×V _{DD}	0.95×V _{DD}		V
V _{OL}	“L” Output Voltage	V _{DD} =4.30V, I _{OUT} =3.2mA		0.18	0.40	V
T _{delay} *2	Output Delay Time for release	Refer to electrical characteristics by Output Delay Time for release				
$\frac{\Delta V_{DET}}{\Delta T_{opt}}$	Detector Threshold Temperature Coefficient	-40°C ≤ T _{opt} ≤ 85°C		±100		ppm/°C

R3130N/R3131N

• R3130N46xx5-TR

[Topt=25°C]

Symbol	Item	Conditions	Min.	Typ.	Max.	Unit
V _{DDH}	Maximum Operating Voltage				6.0	V
V _{DDL} *1	Minimum Operating Voltage	I _{OL} =50μA		0.75	1.00	V
V _{DET}	Detector Threshold		4.581	4.650	4.719	V
I _{SS1}	Supply Current1	V _{DD} =6.00V		1.40	5.00	μA
I _{SS2}	Supply Current2	V _{DD} =4.75V		1.30	4.00	μA
I _{SS3}	Supply Current3	V _{DD} =4.55V		1.15	3.50	μA
V _{OH}	“H” Output Voltage	V _{DD} =4.75V, I _{OUT} =-800μA	0.8×V _{DD}	0.95×V _{DD}		V
V _{OL}	“L” Output Voltage	V _{DD} =4.55V, I _{OUT} =3.2mA		0.18	0.40	V
Tdelay *2	Output Delay Time for release	Refer to electrical characteristics by Output Delay Time for release				
ΔV _{DET} / ΔTopt	Detector Threshold Temperature Coefficient	-40°C ≤ Topt ≤ 85°C		±100		ppm/°C

• R3131N26xx3-TR

[Topt=25°C]

Symbol	Item	Conditions	Min.	Typ.	Max.	Unit
V _{DDH}	Maximum Operating Voltage				6.0	V
V _{DDL} *3	Minimum Operating Voltage	CMOS Output	I _{OH} =-10μA	0.90	1.00	V
		Nch Open Drain Output				
V _{DET}	Detector Threshold		2.591	2.630	2.669	V
I _{SS1}	Supply Current1	V _{DD} =6.00V		1.40	5.00	μA
I _{SS2}	Supply Current2	V _{DD} =2.73V		1.25	4.00	μA
I _{SS3}	Supply Current3	V _{DD} =2.53V		1.10	3.50	μA
V _{OH}	“H” Output Voltage	V _{DD} =2.73V, I _{OUT} =-500μA	0.8×V _{DD}	0.93×V _{DD}		V
V _{OL}	“L” Output Voltage	V _{DD} =2.53V, I _{OUT} =1.2mA		0.16	0.30	V
Tdelay *2	Output Delay Time for release	Refer to electrical characteristics by Output Delay Time for release				
ΔV _{DET} / ΔTopt	Detector Threshold Temperature Coefficient	-40°C ≤ Topt ≤ 85°C		±100		ppm/°C

● R3131N29xx3-TR

[Topt=25°C]

Symbol	Item	Conditions	Min.	Typ.	Max.	Unit
V _{DDH}	Maximum Operating Voltage				6.0	V
V _{DDL} *3	Minimum Operating Voltage	CMOS Output		0.90	1.00	V
		Nch Open Drain Output				
V _{DET}	Detector Threshold		2.887	2.930	2.973	V
I _{SS1}	Supply Current1	V _{DD} =6.00V		1.40	5.00	μA
I _{SS2}	Supply Current2	V _{DD} =3.03V		1.25	4.00	μA
I _{SS3}	Supply Current3	V _{DD} =2.83V		1.10	3.50	μA
V _{OH}	“H” Output Voltage	V _{DD} =2.83V, I _{OUT} =-500μA	0.8×V _{DD}	0.93×V _{DD}		V
V _{OL}	“L” Output Voltage	V _{DD} =3.03V, I _{OUT} =1.2mA		0.16	0.30	V
T _{delay} *2	Output Delay Time for release	Refer to electrical characteristics by Output Delay Time for release				
ΔV _{DET} / ΔT _{opt}	Detector Threshold Temperature Coefficient	-40°C ≤ T _{opt} ≤ 85°C		±100		ppm/°C

● R3131N30xx8-TR

[Topt=25°C]

Symbol	Item	Conditions	Min.	Typ.	Max.	Unit
V _{DDH}	Maximum Operating Voltage				6.0	V
V _{DDL} *3	Minimum Operating Voltage	CMOS Output		0.90	1.00	V
		Nch Open Drain Output				
V _{DET}	Detector Threshold		3.034	3.080	3.126	V
I _{SS1}	Supply Current1	V _{DD} =6.00V		1.40	5.00	μA
I _{SS2}	Supply Current2	V _{DD} =3.18V		1.25	4.00	μA
I _{SS3}	Supply Current3	V _{DD} =2.98V		1.10	3.50	μA
V _{OH}	“H” Output Voltage	V _{DD} =2.98V, I _{OUT} =-500μA	0.8×V _{DD}	0.93×V _{DD}		V
V _{OL}	“L” Output Voltage	V _{DD} =3.18V, I _{OUT} =1.2mA		0.16	0.30	V
T _{delay} *2	Output Delay Time for release	Refer to electrical characteristics by Output Delay Time for release				
ΔV _{DET} / ΔT _{opt}	Detector Threshold Temperature Coefficient	-40°C ≤ T _{opt} ≤ 85°C		±100		ppm/°C

R3130N/R3131N

• R3131N40xx-TR

[Topt=25°C]

Symbol	Item	Conditions	Min.	Typ.	Max.	Unit
V _{DDH}	Maximum Operating Voltage				6.0	V
V _{DDL} *3	Minimum Operating Voltage	CMOS Output		0.90	1.00	V
		Nch Open Drain Output				
V _{DET}	Detector Threshold		3.940	4.000	4.060	V
I _{SS1}	Supply Current1	V _{DD} =6.00V		1.40	5.00	μA
I _{SS2}	Supply Current2	V _{DD} =3.90V		1.30	4.00	μA
I _{SS3}	Supply Current3	V _{DD} =4.10V		1.15	3.50	μA
V _{OH}	“H” Output Voltage	V _{DD} =3.90V, I _{OUT} =-800μA	0.8×V _{DD}	0.95×V _{DD}		V
V _{OL}	“L” Output Voltage	V _{DD} =4.10V, I _{OUT} =3.2mA		0.18	0.40	V
Tdelay *2	Output Delay Time for release	Refer to electrical characteristics by Output Delay Time for release				
ΔV _{DET} / ΔT _{opt}	Detector Threshold Temperature Coefficient	-40°C ≤ T _{opt} ≤ 85°C		±100		ppm/°C

• R3131N44xx-TR

[Topt=25°C]

Symbol	Item	Conditions	Min.	Typ.	Max.	Unit
V _{DDH}	Maximum Operating Voltage				6.0	V
V _{DDL} *3	Minimum Operating Voltage	CMOS Output		0.90	1.00	V
		Nch Open Drain Output				
V _{DET}	Detector Threshold		4.334	4.400	4.466	V
I _{SS1}	Supply Current1	V _{DD} =6.00V		1.40	5.00	μA
I _{SS2}	Supply Current2	V _{DD} =4.50V		1.30	4.00	μA
I _{SS3}	Supply Current3	V _{DD} =4.30V		1.15	3.50	μA
V _{OH}	“H” Output Voltage	V _{DD} =4.30V, I _{OUT} =-800μA	0.8×V _{DD}	0.95×V _{DD}		V
V _{OL}	“L” Output Voltage	V _{DD} =4.50V, I _{OUT} =3.2mA		0.18	0.40	V
Tdelay *2	Output Delay Time for release	Refer to electrical characteristics by Output Delay Time for release				
ΔV _{DET} / ΔT _{opt}	Detector Threshold Temperature Coefficient	-40°C ≤ T _{opt} ≤ 85°C		±100		ppm/°C

● R3131N46xx5-TR

[Topt=25°C]

Symbol	Item	Conditions	Min.	Typ.	Max.	Unit
V _{DDH}	Maximum Operating Voltage				6.0	V
V _{DDL} *3	Minimum Operating Voltage	CMOS Output I _{OH} =-10μA		0.90	1.00	V
		Nch Open Drain Output V _{DS} =6.5V				
V _{DET}	Detector Threshold		4.581	4.650	4.719	V
I _{SS1}	Supply Current1	V _{DD} =6.00V		1.40	5.00	μA
I _{SS2}	Supply Current2	V _{DD} =4.75V		1.30	4.00	μA
I _{SS3}	Supply Current3	V _{DD} =4.55V		1.15	3.50	μA
V _{OH}	"H" Output Voltage	V _{DD} =4.55V, I _{OUT} =-800μA	0.8×V _{DD}	0.95×V _{DD}		V
V _{OL}	"L" Output Voltage	V _{DD} =4.75V, I _{OUT} =3.2mA		0.18	0.40	V
T _{delay} *2	Output Delay Time for release	Refer to electrical characteristics by Output Delay Time for release				
ΔV _{DET} / ΔT _{opt}	Detector Threshold Temperature Coefficient	-40°C ≤ T _{opt} ≤ 85°C		±100		ppm/°C

- *1) Supply Voltage when Output Voltage becomes equal or less than 0.3V. (As for Nch Open Drain Output type, pull-up resistor is 470kΩ, pull-up voltage is 5.0V.)
- *2) Time interval of rising edge of V_{DD} which is set from 1.0V to V_{DET}+1.0V, and the point of which Output voltage reaches to 50% of final voltage.
- *3) CMOS Output type; Supply Voltage when Output Voltage becomes equal or more than 0.8×V_{DD}.
Nch Open Drain type; Supply Voltage when off leakage current becomes equal or less than 0.1μA.

ELECTRICAL CHARACTERISTICS BY OUTPUT DELAY TIME

[Topt=25°C]

Part Number	Test Condition	Output Delay Time (T _{delay})			Unit
		Min.	Typ.	Max.	
R313xNxxAx	V _{DD} =1.0V to V _{DET} +1.0V	45	50	55	ms
R313xNxxBx		90	100	110	
R313xNxxDx		180	200	220	
R313xNxxEx		216	240	264	
R313xNxxHx		360	400	440	

ELECTRICAL CHARACTERISTICS BY DETECTOR THRESHOLD

• R3130N16EA/C to R3130N48EA/C

Part Number	Detector Threshold			Supply Current 1			Supply Current 2			Supply Current 3									
	V _{DET} (V)			I _{SS1} (μA)			I _{SS2} (μA)			I _{SS3} (μA)									
	Min.	Typ.	Max.	Condition	Typ.	Max.	Condition	Typ.	Max.	Condition	Typ.	Max.							
R3130N16EA/C	1.576	1.600	1.624	V _{DD} =6.0V	1.40	5.00	V _{DD} =V _{DET} +0.1V	1.20	4.00	1.00	V _{DD} =V _{DET} -0.1V	3.50							
R3130N17EA/C	1.675	1.700	1.725																
R3130N18EA/C	1.773	1.800	1.827																
R3130N19EA/C	1.872	1.900	1.928																
R3130N20EA/C	1.970	2.000	2.030																
R3130N21EA/C	2.069	2.100	2.131																
R3130N22EA/C	2.167	2.200	2.233																
R3130N23EA/C	2.266	2.300	2.334																
R3130N24EA/C	2.364	2.400	2.436																
R3130N25EA/C	2.463	2.500	2.537																
R3130N26EA/C	2.561	2.600	2.639																
R3130N27EA/C	2.660	2.700	2.740																
R3130N28EA/C	2.758	2.800	2.842																
R3130N29EA/C	2.857	2.900	2.943																
R3130N30EA/C	2.955	3.000	3.045																
R3130N31EA/C	3.054	3.100	3.146																
R3130N32EA/C	3.152	3.200	3.248																
R3130N33EA/C	3.251	3.300	3.349																
R3130N34EA/C	3.349	3.400	3.451																
R3130N35EA/C	3.448	3.500	3.552																
R3130N36EA/C	3.546	3.600	3.654																
R3130N37EA/C	3.645	3.700	3.755																
R3130N38EA/C	3.743	3.800	3.857																
R3130N39EA/C	3.842	3.900	3.958																
R3130N40EA/C	3.940	4.000	4.060																
R3130N41EA/C	4.039	4.100	4.161																
R3130N42EA/C	4.137	4.200	4.263																
R3130N43EA/C	4.236	4.300	4.364																
R3130N44EA/C	4.334	4.400	4.466																
R3130N45EA/C	4.433	4.500	4.567																
R3130N46EA/C	4.531	4.600	4.669																
R3130N47EA/C	4.630	4.700	4.770																
R3130N48EA/C	4.728	4.800	4.872																
															1.25		1.10		
															1.30		1.15		

T_{opt}=25°C

“H” Output Voltage			“L” Output Voltage			Minimum Operating Voltage		Output Delay Time			Detector Threshold Temperature Coefficient	
V _{OH} (V)			V _{OL} (V)			V _{DDL} (V)		T _{delay} (ms)			ΔV _{DET} /ΔT _{opt} (ppm/°C)	
Condition	Min.	Typ.	Condition	Typ.	Max.	Typ.	Max.	Min.	Typ.	Max.	Condition	Typ.
V _{DD} =V _{DET} +0.1V I _{OH} = -150μA	0.80× V _{DD}	0.95× V _{DD}	V _{DD} =V _{DET} -0.1V, I _{OL} =1.2mA	0.16	0.30	*1 0.75	*1 1.00	216	240	264	-40°C ≤ T _{opt} ≤ 85°C	±100
V _{DD} =V _{DET} +0.1V I _{OH} = -500μA	0.80× V _{DD}	0.93× V _{DD}										
V _{DD} =V _{DET} +0.1V I _{OH} = -800μA	0.80× V _{DD}	0.95× V _{DD}	V _{DD} =V _{DET} -0.1V, I _{OL} =3.2mA	0.18	0.40							

*1describes V_{DD} Voltage when Output Voltage becomes equal or less than 0.3V.

R3130N/R3131N

• R3131N16EA/C to R3131N48EA/C

Part Number	Detector Threshold			Supply Current 1			Supply Current 2			Supply Current 3		
	V _{DET} (V)			I _{SS1} (μA)			I _{SS2} (μA)			I _{SS3} (μA)		
	Min.	Typ.	Max.	Condition	Typ.	Max.	Condition	Typ.	Max.	Condition	Typ.	Max.
R3131N16EA/C	1.576	1.600	1.624	V _{DD} =6.0V	1.40	5.00	V _{DD} =V _{DET} +0.1V	1.20	4.00	V _{DD} =V _{DET} -0.1V	1.00	3.50
R3131N17EA/C	1.675	1.700	1.725									
R3131N18EA/C	1.773	1.800	1.827									
R3131N19EA/C	1.872	1.900	1.928									
R3131N20EA/C	1.970	2.000	2.030									
R3131N21EA/C	2.069	2.100	2.131									
R3131N22EA/C	2.167	2.200	2.233									
R3131N23EA/C	2.266	2.300	2.334									
R3131N24EA/C	2.364	2.400	2.436									
R3131N25EA/C	2.463	2.500	2.537									
R3131N26EA/C	2.561	2.600	2.639									
R3131N27EA/C	2.660	2.700	2.740									
R3131N28EA/C	2.758	2.800	2.842									
R3131N29EA/C	2.857	2.900	2.943									
R3131N30EA/C	2.955	3.000	3.045									
R3131N31EA/C	3.054	3.100	3.146									
R3131N32EA/C	3.152	3.200	3.248									
R3131N33EA/C	3.251	3.300	3.349									
R3131N34EA/C	3.349	3.400	3.451									
R3131N35EA/C	3.448	3.500	3.552									
R3131N36EA/C	3.546	3.600	3.654									
R3131N37EA/C	3.645	3.700	3.755									
R3131N38EA/C	3.743	3.800	3.857									
R3131N39EA/C	3.842	3.900	3.958									
R3131N40EA/C	3.940	4.000	4.060									
R3131N41EA/C	4.039	4.100	4.161									
R3131N42EA/C	4.137	4.200	4.263									
R3131N43EA/C	4.236	4.300	4.364									
R3131N44EA/C	4.334	4.400	4.466									
R3131N45EA/C	4.433	4.500	4.567									
R3131N46EA/C	4.531	4.600	4.669									
R3131N47EA/C	4.630	4.700	4.770									
R3131N48EA/C	4.728	4.800	4.872									

T_{opt}=25°C

“H” Output Voltage			“L” Output Voltage			Minimum Operating Voltage		Output Delay Time			Detector Threshold Temperature Coefficient	
V _{OH} (V)			V _{OL} (V)			V _{DDL} (V)		T _{delay} (ms)			ΔV _{DET} /ΔT _{opt} (ppm/°C)	
Condition	Min.	Typ.	Condition	Typ.	Max.	Typ.	Max.	Min.	Typ.	Max.	Condition	Typ
V _{DD} =V _{DET} -0.1V I _{OH} = -150μA	0.80× V _{DD}	0.95× V _{DD}	V _{DD} =V _{DET} +0.1V, I _{OL} =1.2mA	0.16	0.30	*2 0.90	*2 1.00	216	240	264	-40°C ≤ T _{opt} ≤ 85°C	±100
V _{DD} =V _{DET} -0.1V I _{OH} = -500μA	0.80× V _{DD}	0.93× V _{DD}										
V _{DD} =V _{DET} -0.1V I _{OH} = -800μA	0.80× V _{DD}	0.95× V _{DD}	V _{DD} =V _{DET} +0.1V, I _{OL} =3.2mA	0.18	0.40							

*2 CMOS Output Type; describes V_{DD} voltage when Output Voltage becomes equal or more than V_{DD}×0.8V

Nch Open Drain Output Type; describes V_{DD} voltage when Off-leakage Current becomes equal or less than 0.1μA.

OPERATION

• Operation of R3130N Series

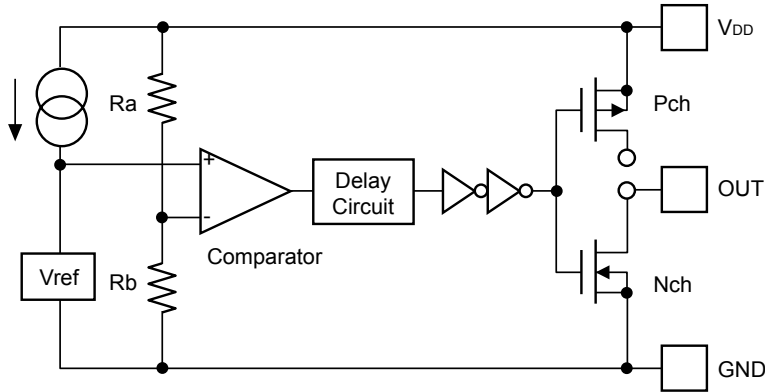

- CMOS output type
OUT pin is connected to the drain of Nch Tr. and Pch Tr. in this IC.
- Nch open drain output type
OUT pin is connected to the drain of Nch Tr. in this IC. (OUT pin should be pulled up to V_{DD} or an external voltage level.)

Block Diagram

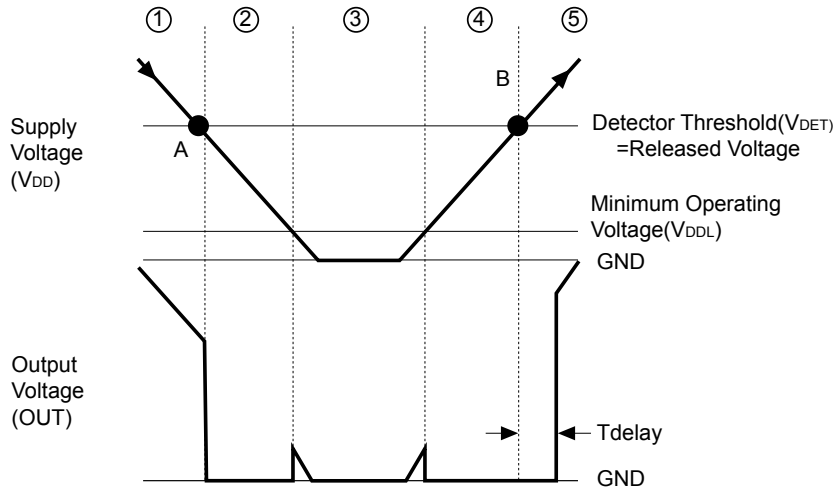

Operating Diagram

In the above diagram,

- ① Output voltage becomes equal to supply voltage (Nch open drain output Type; equal to pull-up Voltage).
- ② When supply voltage is down to the detector threshold level (Point A), $V_{ref} \geq V_{DD} \times R_b / (R_a + R_b)$ is true. Then, Output of the comparator is reversed, thus output voltage becomes equal to GND level.
- ③ When supply voltage is lower than minimum operating voltage, output of transistor is indefinite, therefore output is also indefinite.
- ④ Output voltage is equal to GND level.
- ⑤ When supply voltage is higher than released voltage (Point B), $V_{ref} \leq V_{DD} \times R_b / (R_a + R_b)$ is true. Then output of the comparator is reversed, thus output voltage becomes equal to supply voltage (Nch open drain output type; equal to pull-up voltage).

* There is no hysteresis range between detector threshold and released voltage.

• Operation of R3131N Series

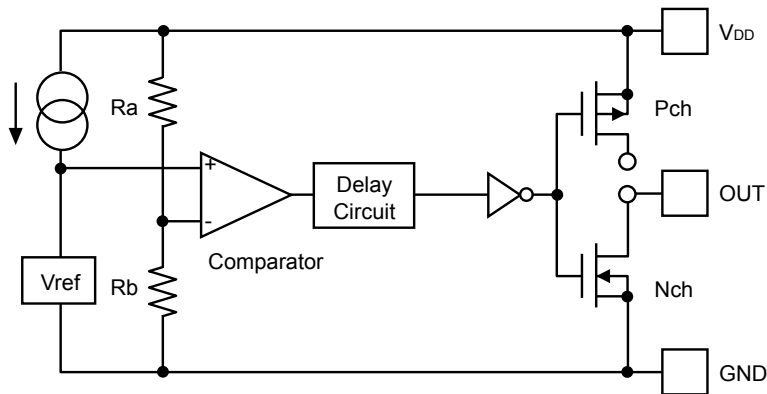

Block Diagram

- CMOS output type
OUT pin is connected to the drain of Nch Tr. and Pch Tr. in this IC.
- Nch open drain output type: I
OUT pin is connected to the drain of Nch Tr. in this IC. (OUT pin should be pulled up to V_{DD} or an external voltage level.)

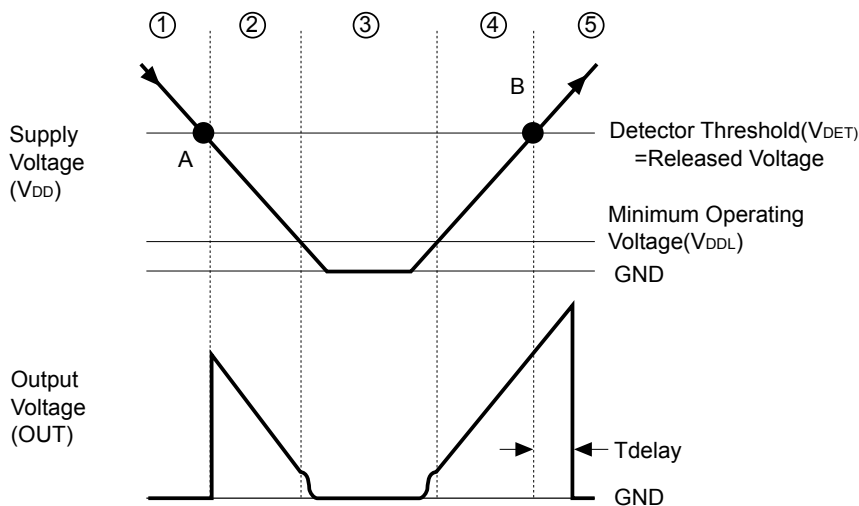

Operation Diagram

In the above diagram,

- ① Output voltage becomes equal to GND level.
- ② When supply voltage is down to the detector threshold level (Point A), $V_{ref} \geq V_{DD} \times R_b / (R_a + R_b)$ is true. Then, output of the comparator is reversed, thus output voltage becomes equal to supply voltage (Nch open drain output type; equal to pull-up Voltage).
- ③ When supply voltage is lower than minimum operating voltage, Output of transistor is indefinite, therefore output is also indefinite. (Nch open drain output type; Output voltage level is equal to pull-up voltage.)
- ④ Output voltage is equal to supply voltage. (Nch open drain output type; equal to pull-up voltage.)
- ⑤ When supply voltage is higher than released voltage (Point B), $V_{ref} \leq V_{DD} \times R_b / (R_a + R_b)$ is true. Then output of the comparator is reversed, thus output voltage becomes equal to GND level after the output delay time.

* There is no hysteresis range between detector threshold and released voltage.

TEST CIRCUITS

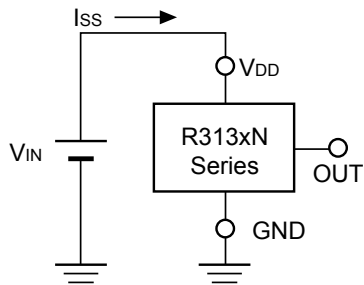

Test Circuit for Supply Current

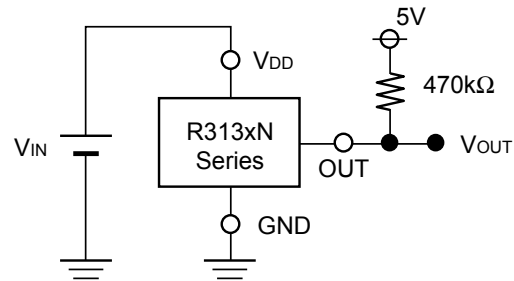

Test Circuit for Detector Threshold
(CMOS Output type; pull-up part is not necessary.)

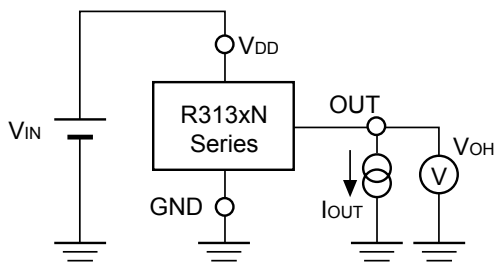

Test Circuit for "H" Output Voltage
(CMOS Output Type only)

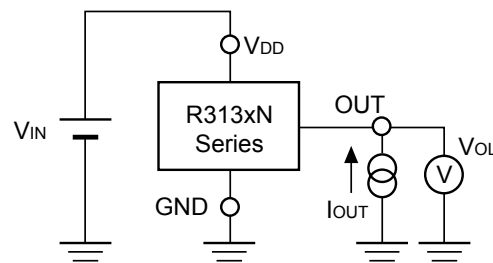

Test Circuit for "L" Output Voltage

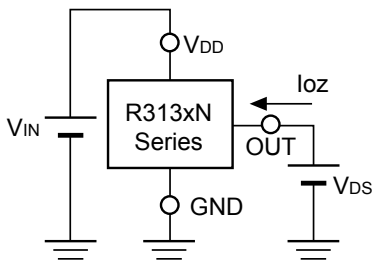

Test Circuit for Off Leakage Current

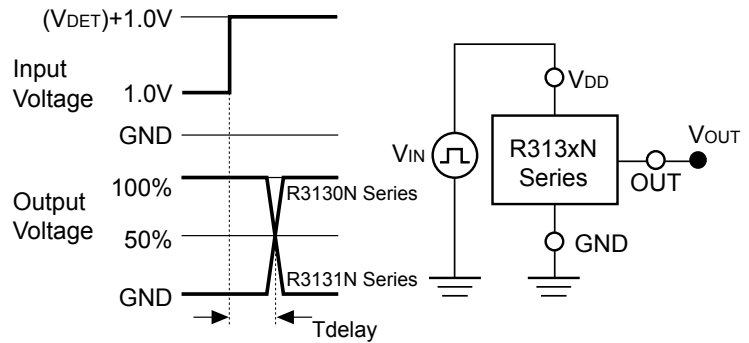

Test Circuit for Output Delay Time
(CMOS Output type; pull-up is not necessary.)

TYPICAL CHARACTERISTICS

1) Supply Current vs. Input Voltage

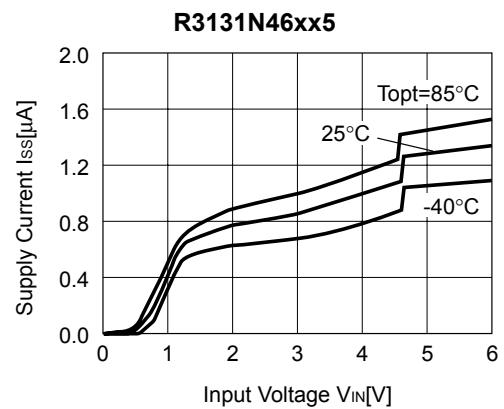
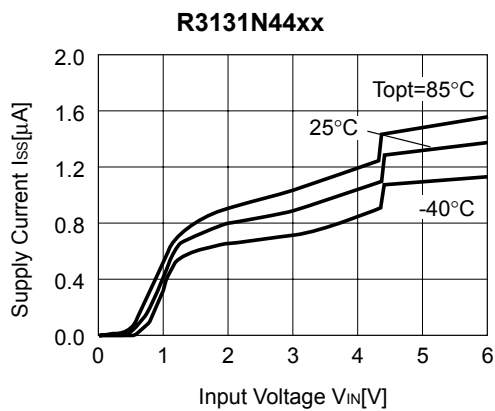
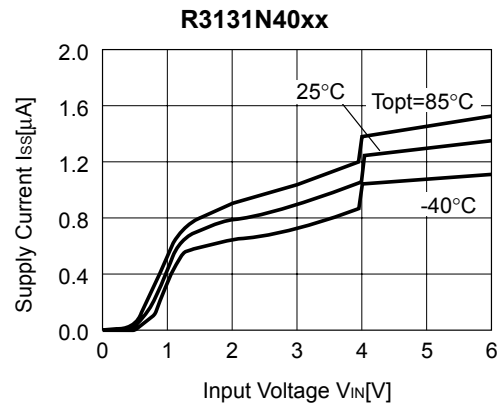
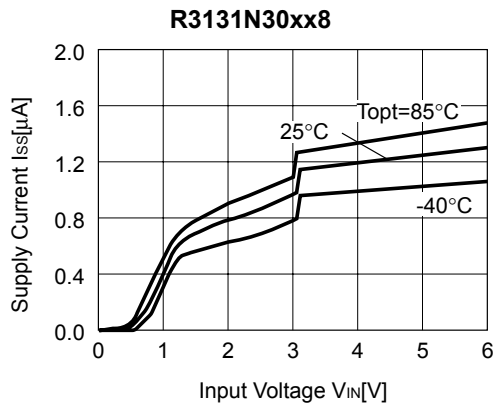
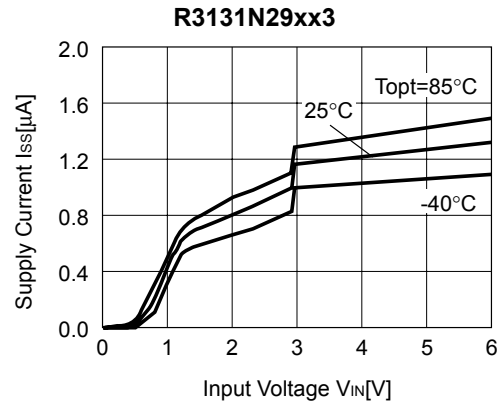
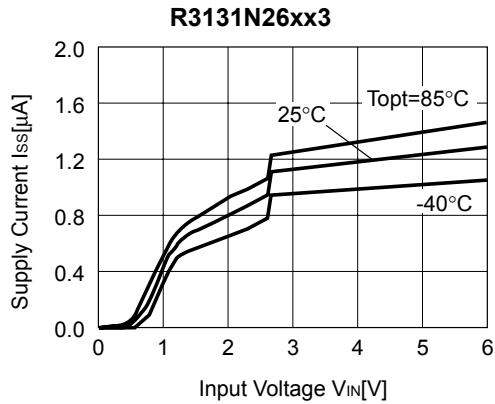

2) Detector Threshold vs. Temperature

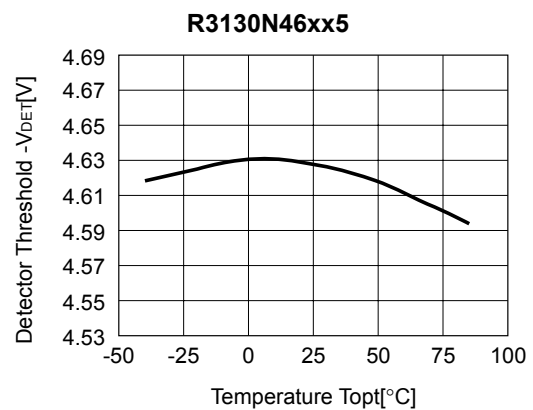
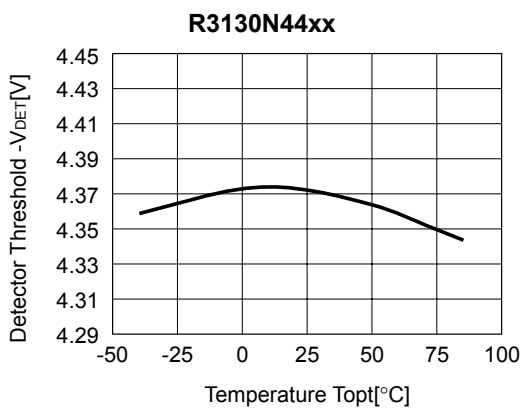
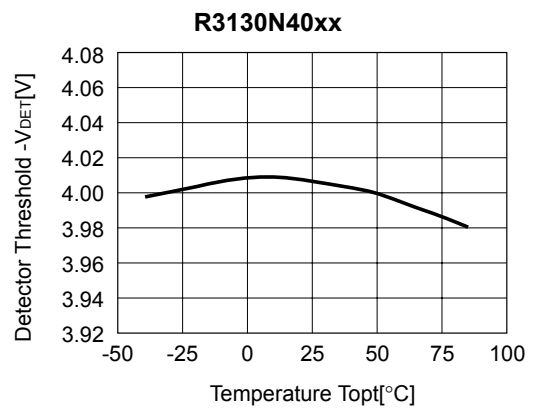
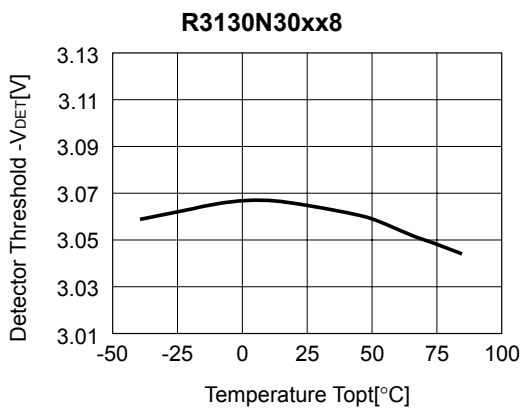
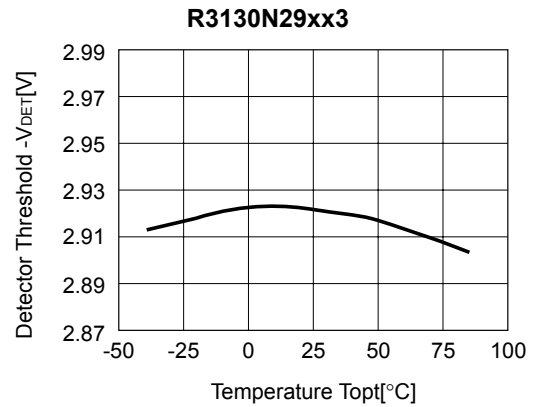
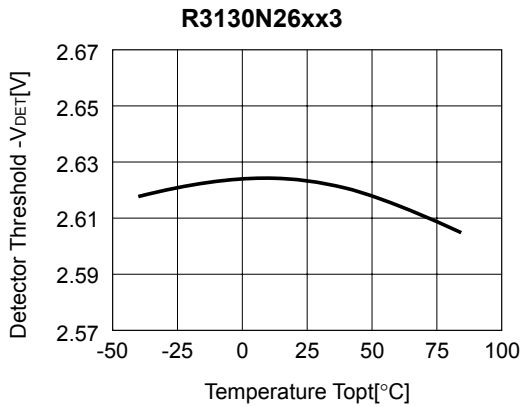

3) Nch Driver Output Current vs. V_{DS}

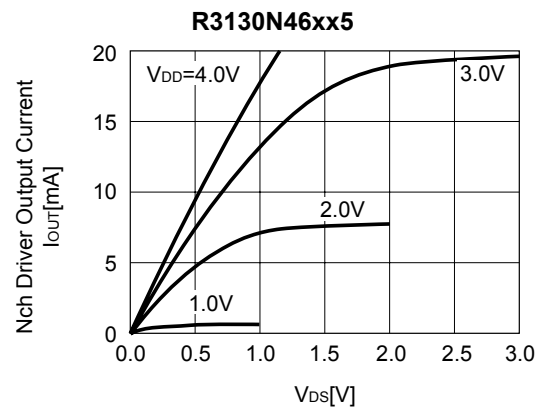
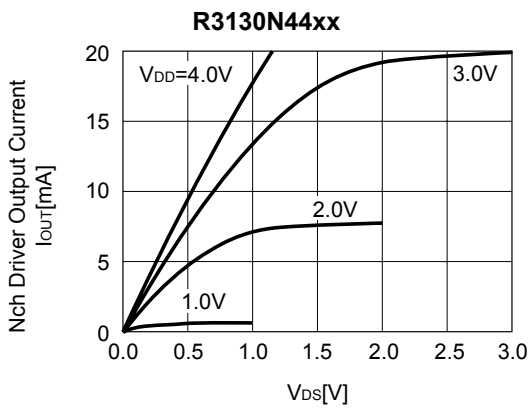
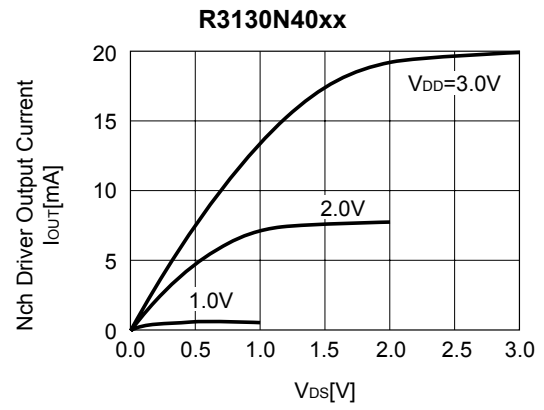
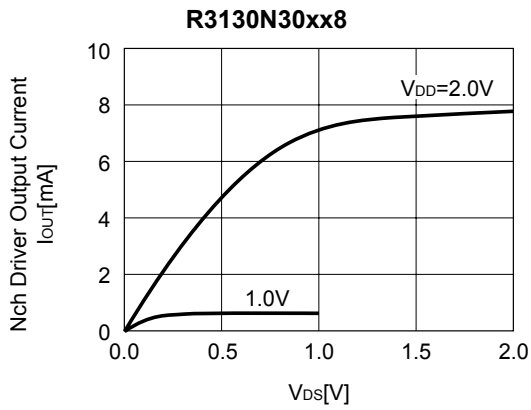
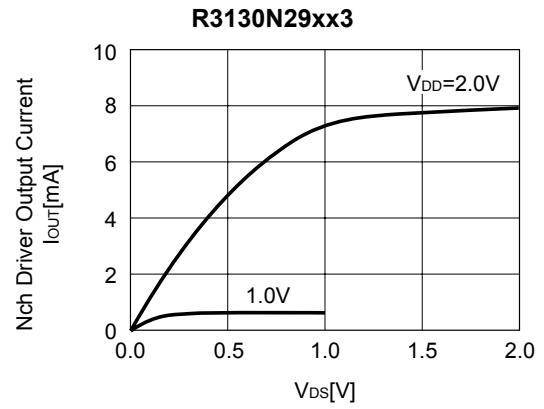
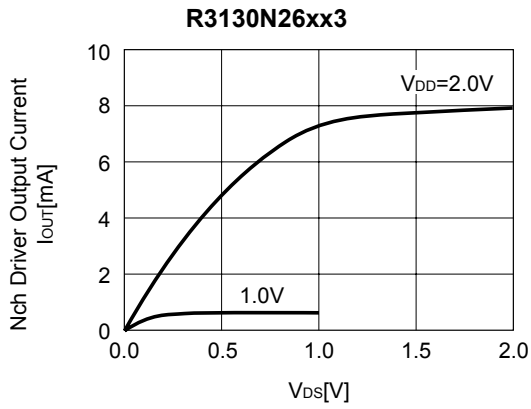

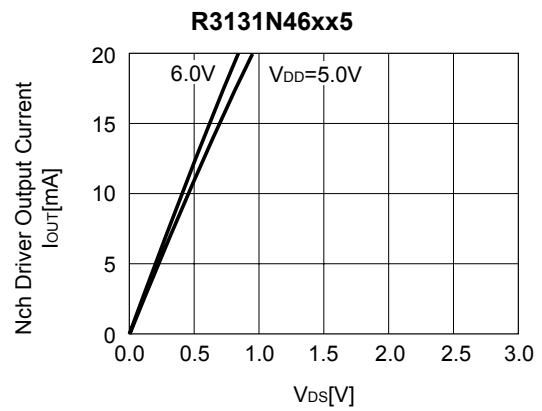
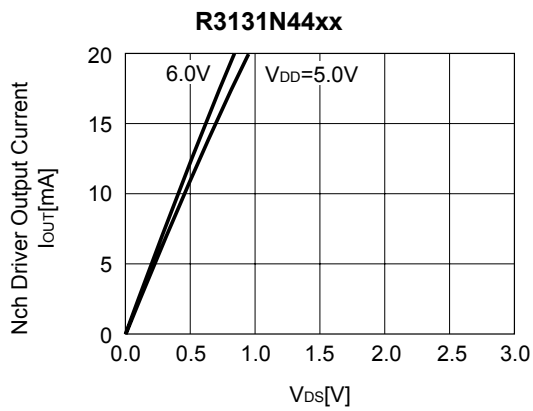
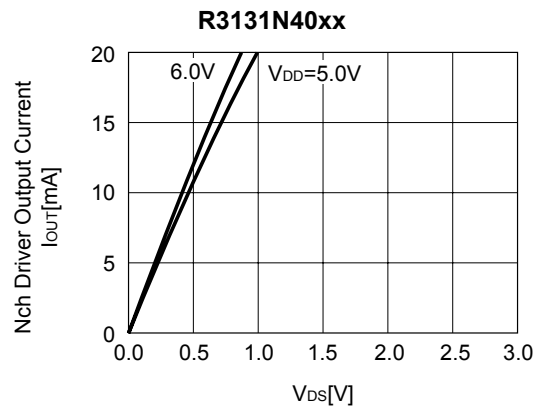
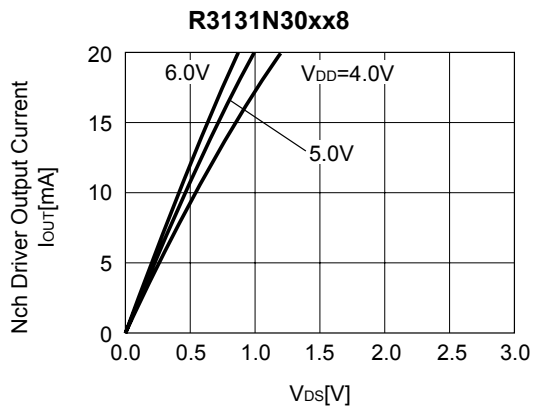
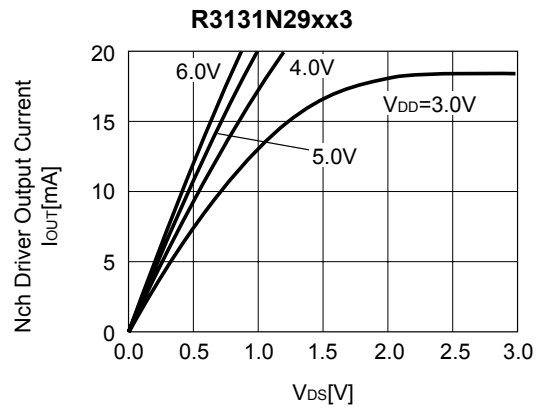
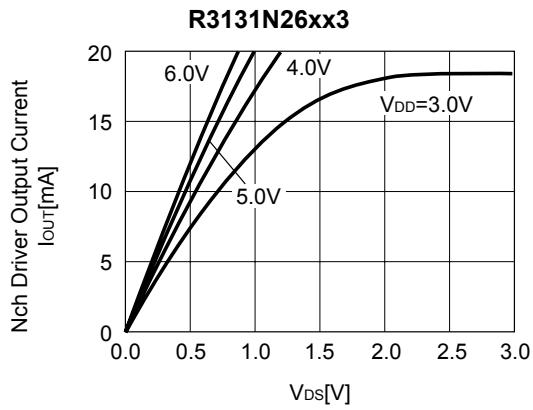

4) Nch Driver Output Current vs. Input Voltage

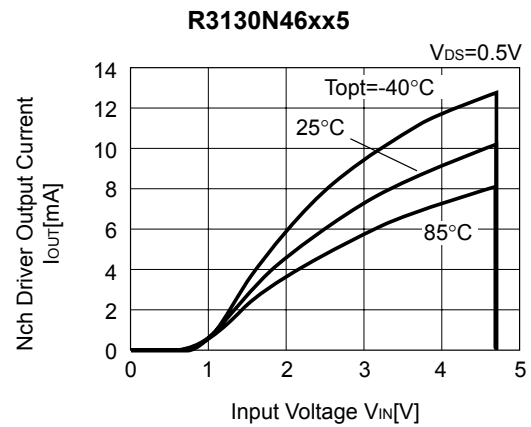
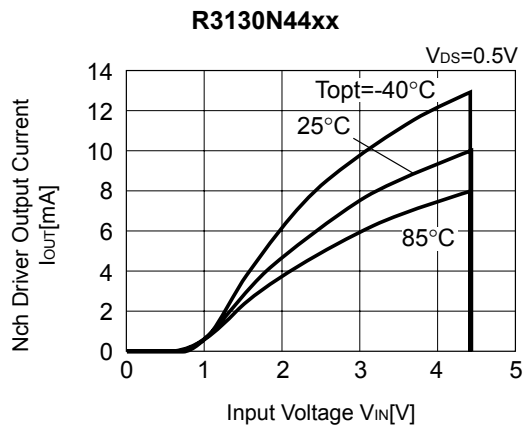
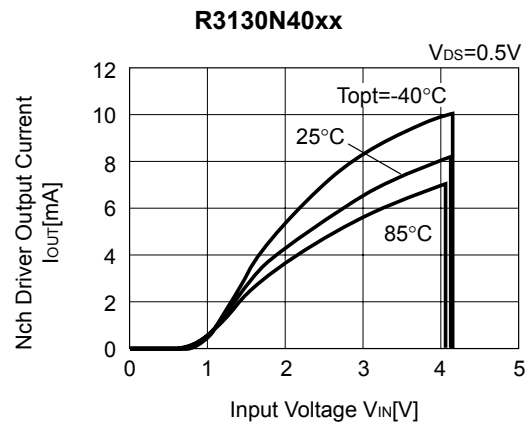
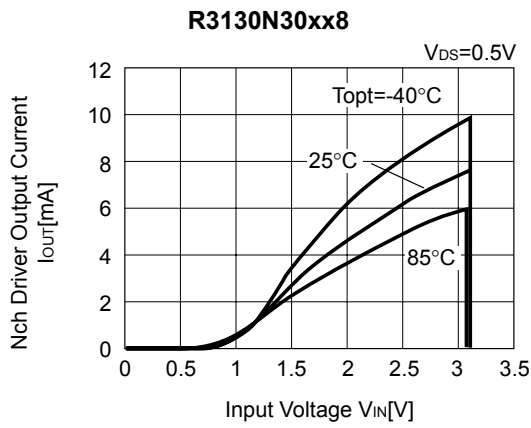
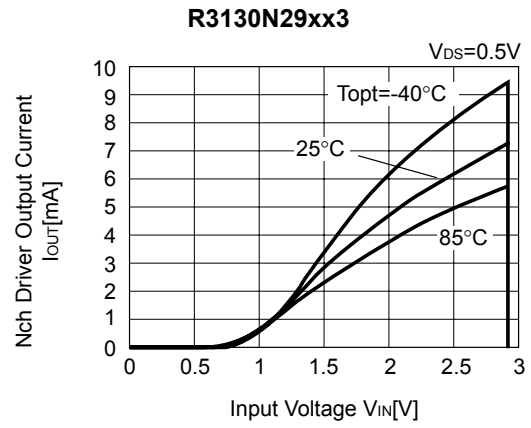
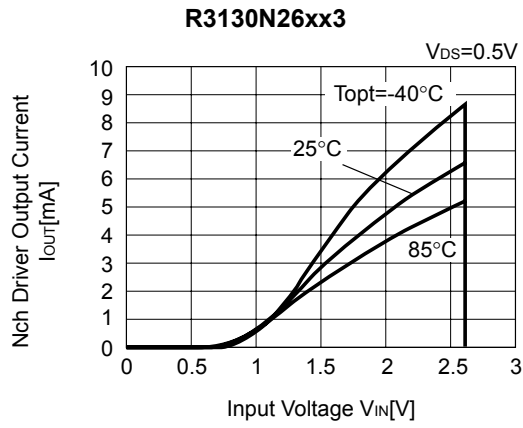

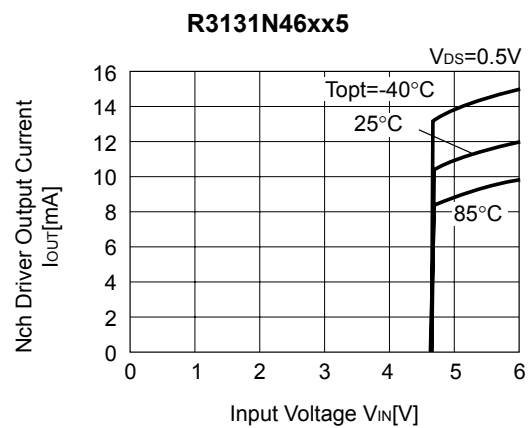
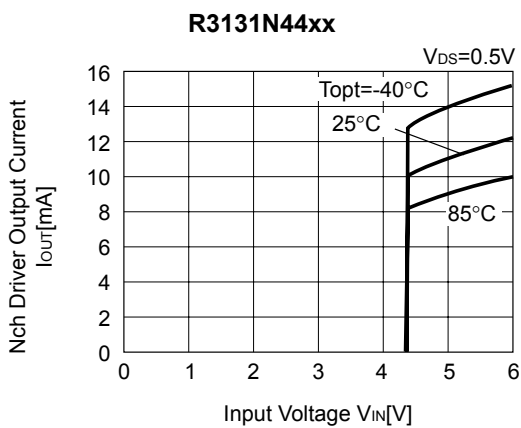
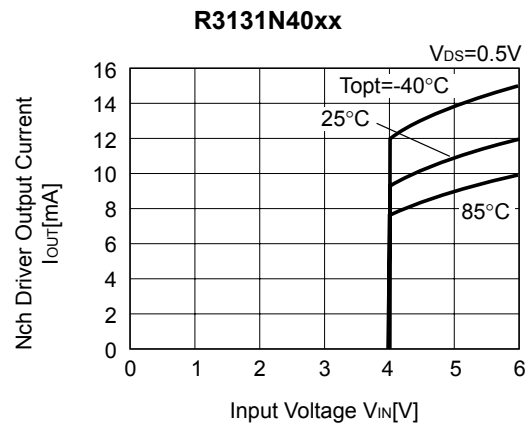
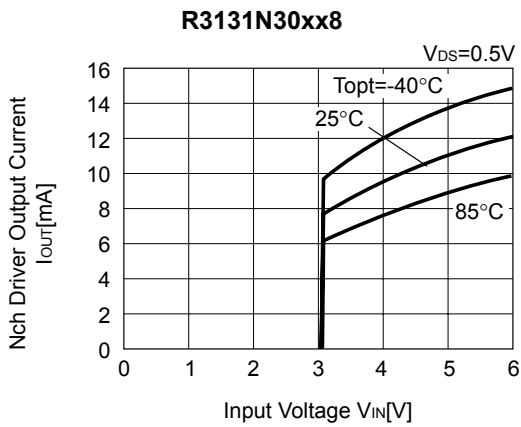
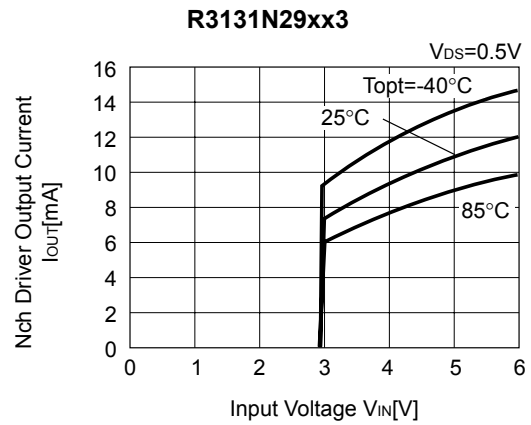
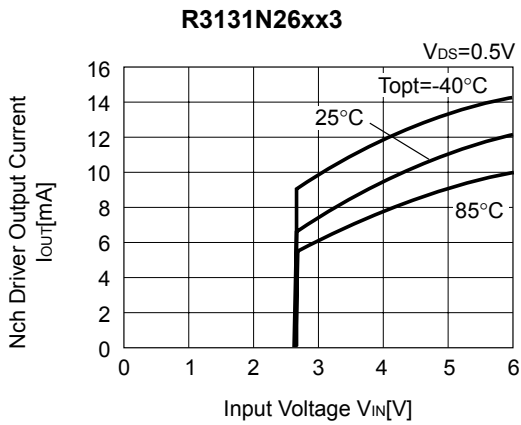

5) Pch Driver Output Current vs. Input Voltage

R3130N26xx3

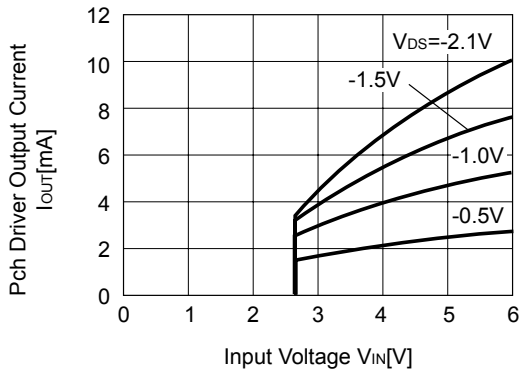

R3130N29xx3

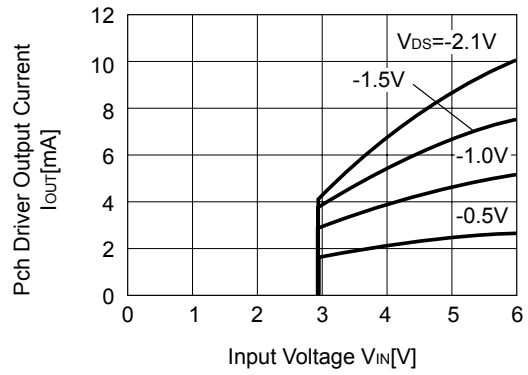

R3130N30xx8

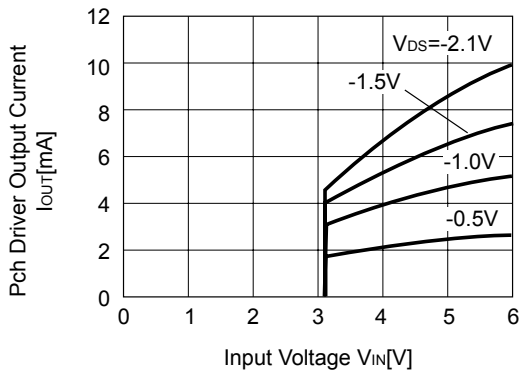

R3130N40xx

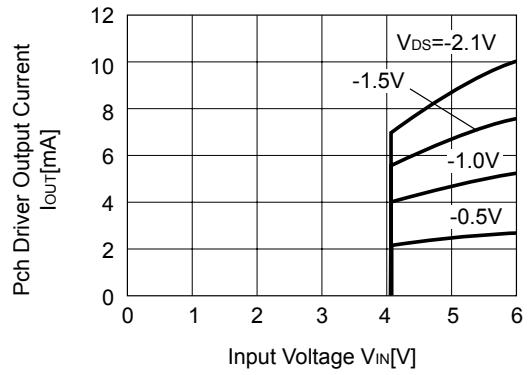

R3130N44xx

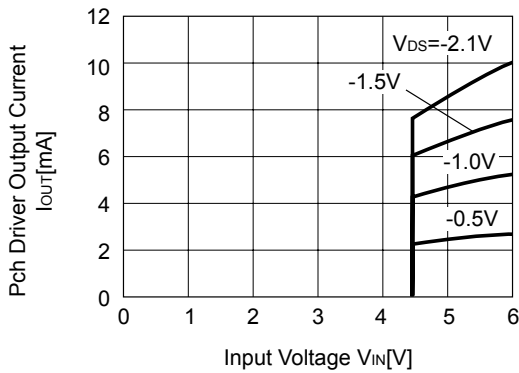

R3130N46xx5

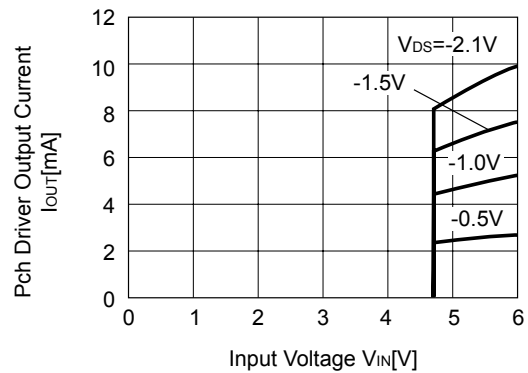

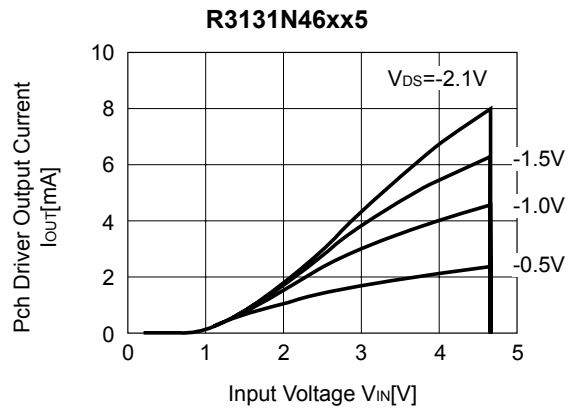
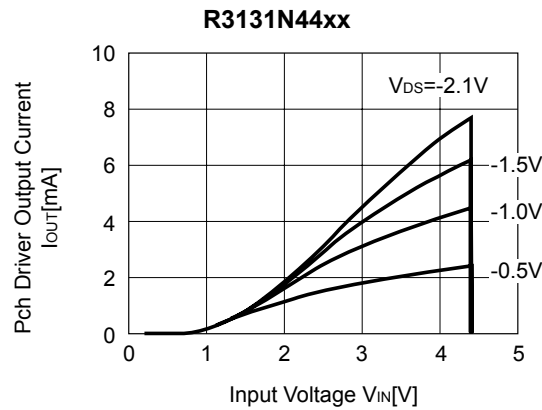
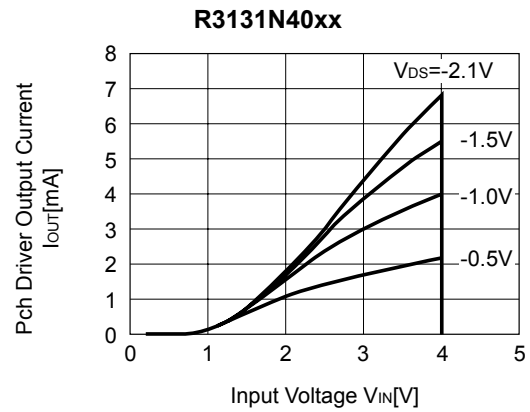
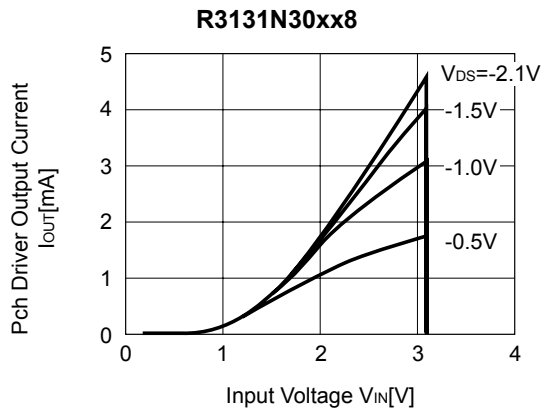
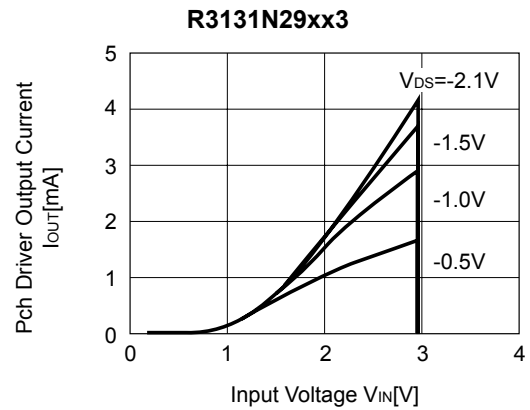
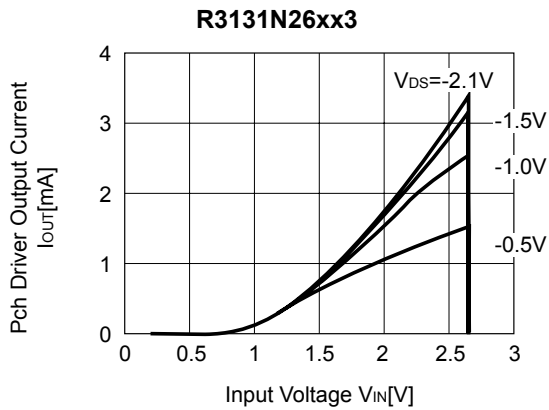

6) Output Delay Time at Detection Mode vs. Temperature

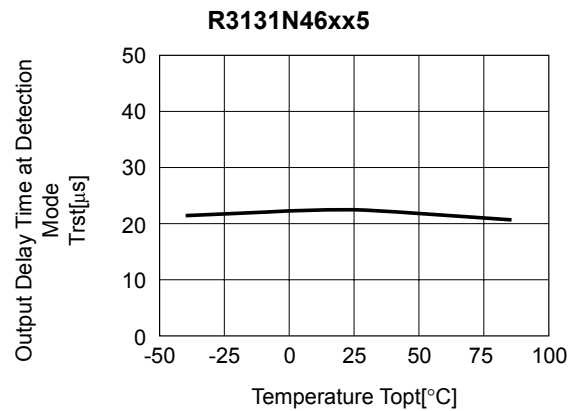
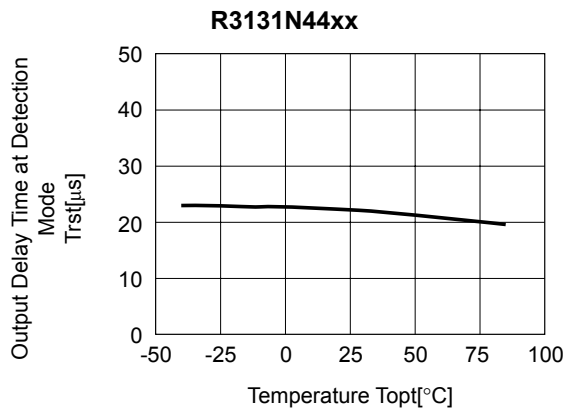
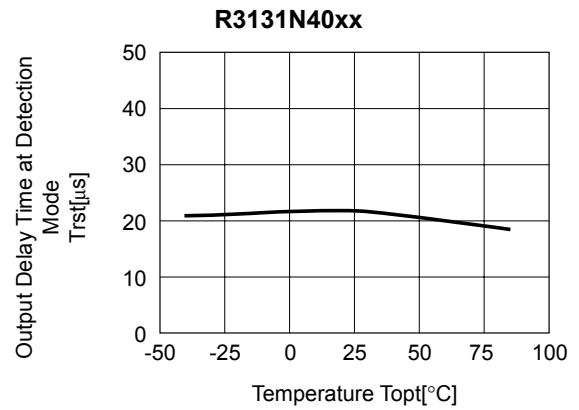
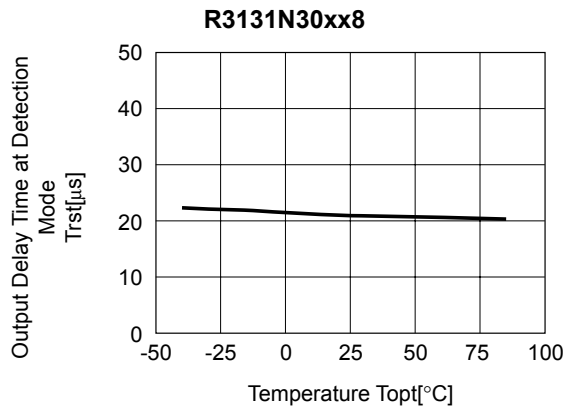
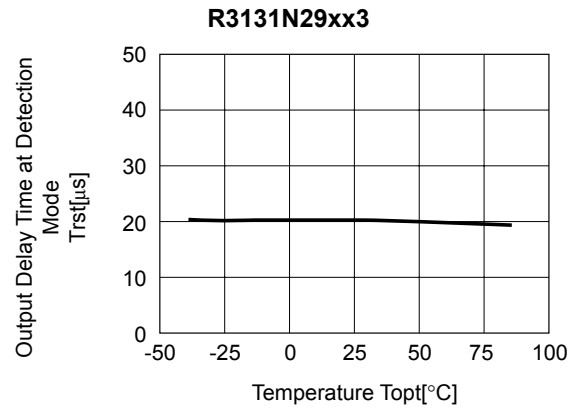
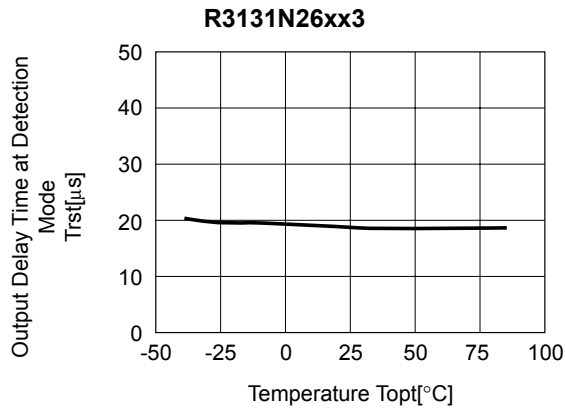

7) Power-on Reset Delay Time vs. Temperature

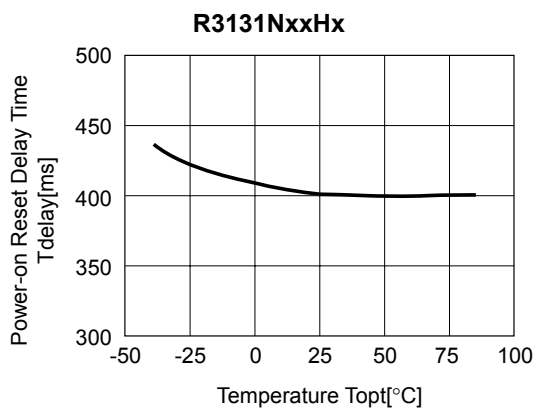
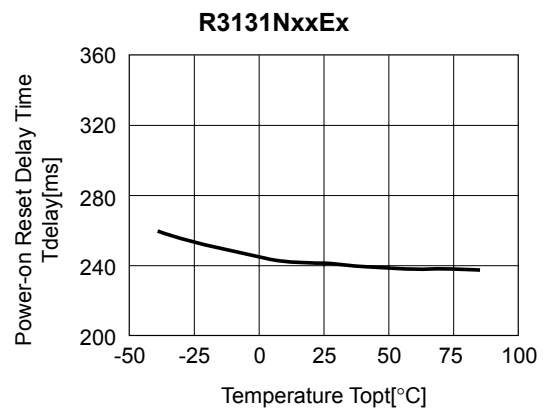
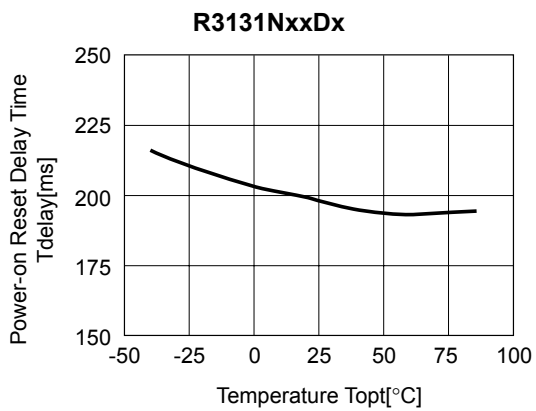
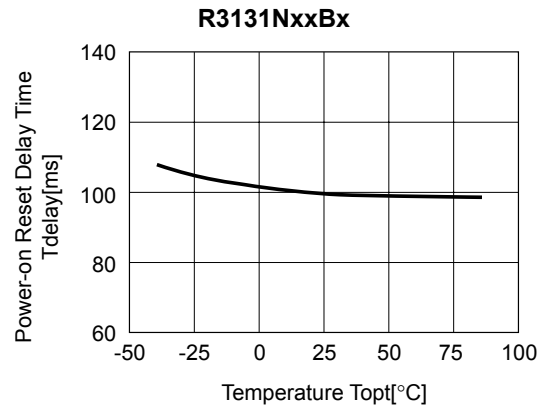
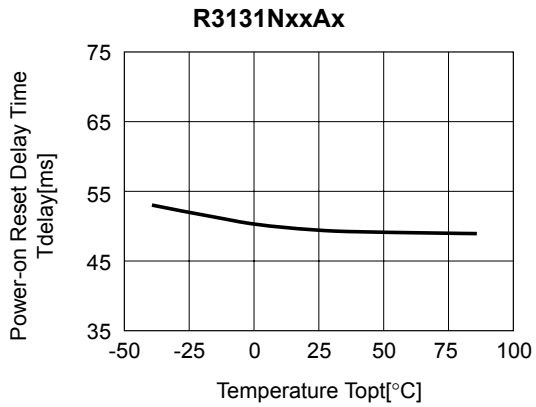

TECHNICAL NOTES

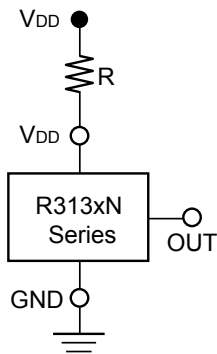

Figure A

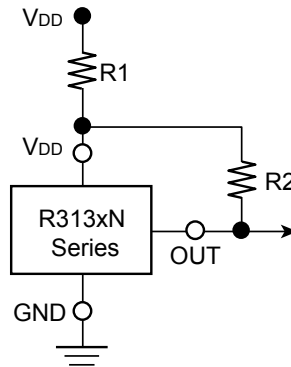

Figure B

As shown wiring in Figure A and Figure B may cause unstable operation by cross conduction current at detection of all types of R313xN Series. The detector threshold may shift because of voltage drop by consumption current of this IC itself.

At the power-on state, if V_{DD} starts up from minimum input voltage (1V) or less very rapidly, the internal initialization may not be finished, and output may be unstable. If the transient time from the minimum input voltage to the detector threshold level at the power-on state is $30\mu\text{s}$ or less, fully evaluation is necessary.