

800mA LDO REGULATOR

NO.EA-084-0607

OUTLINE

The R1170x Series are positive voltage regulator ICs by CMOS process. The R1170x Series have features of high ripple rejection, low dropout voltage, high output voltage accuracy, low consumption current. Each of these ICs consists of a voltage reference unit, an error amplifier, resistor net for setting output voltage, a current limit circuit at short mode, a chip enable circuit, and thermal-shunt circuit. Output Voltage of R1170 is fixed in the IC.

Low consumption current by the merit of CMOS process and built-in transistors with low ON-resistance make low dropout voltage and chip enable function prolong the battery life. These regulators are remarkable improvement on the current regulators in terms of ripple rejection, input transient response, and load transient response.

Maximum Output Current is large for its compact size.

Thus, the R1170x Series are suitable for various power sources for portable appliances.

Since the packages for these ICs are the SOT-89-5 package, HSON-6, or HSOP-6J, high density mounting of the ICs on boards is possible.

FEATURES

- Ultra-Low Supply Current..... Typ. 80 μ A
- Low Standby Current Typ. 0.1 μ A
- Output Current Min. 800mA ($V_{IN}=V_{OUT}+1.0V$)
- Low Dropout Voltage..... Typ. 0.12V ($V_{OUT}=3.0V, I_{OUT}=300mA$)
- High Output Voltage Accuracy $\pm 2.0\%$
- Low Temperature-drift Coefficient of Output Voltage ... Typ. $\pm 100ppm/^{\circ}C$
- Line Regulation Typ. 0.05%/V
- Output Voltage 1.5V to 5.0V
- Small Package SOT-89-5, HSON-6, HSOP-6J
- Built-in Current Limit Circuit
- Built-in Thermal Shutdown Circuit

APPLICATIONS

- Local Power source for Notebook PC.
- Local Power source for portable appliances, cameras, and videos.
- Local Power source for equipment of battery-use.
- Local Power source for home appliances.

BLOCK DIAGRAMS

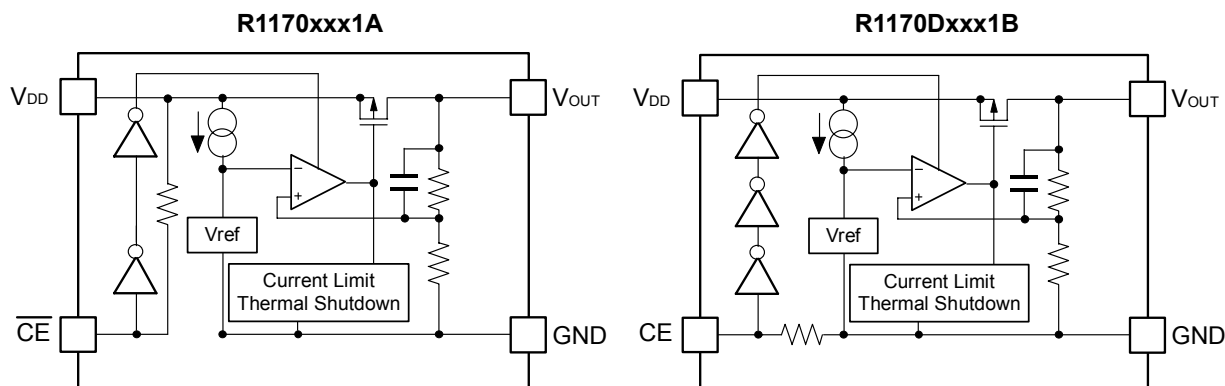

SELECTION GUIDE

The output voltage, the chip-enable polarity, the taping type can be selected at the user's request.
The selection can be made with the part number as follows;

R1170xxx1x-xx-x ← Part Number
 ↑↑ ↑ ↑ ↑
 a b c d e

Code	Contents
a	Package Type; H: SOT-89-5 D: HSON-6 S: HSOP-6J
b	Designation of Output Voltage (V_{OUT}) Stepwise setting with 0.1V increment in the range from 1.5V to 5.0V
c	Designation of option; A: Built-in Chip Enable Circuit, Active at "L" B: Built-in Chip Enable Circuit, Active at "H"
d	Designation of Taping Type; T1 (SOT-89-5), TR (HSON-6), E2 (HSOP-6J) (Refer to Taping Specifications)
e	Designation of composition of pin plating -F: Lead free plating (SOT-89-5,HSON-6,HSOP-6J)

PIN CONFIGURATION

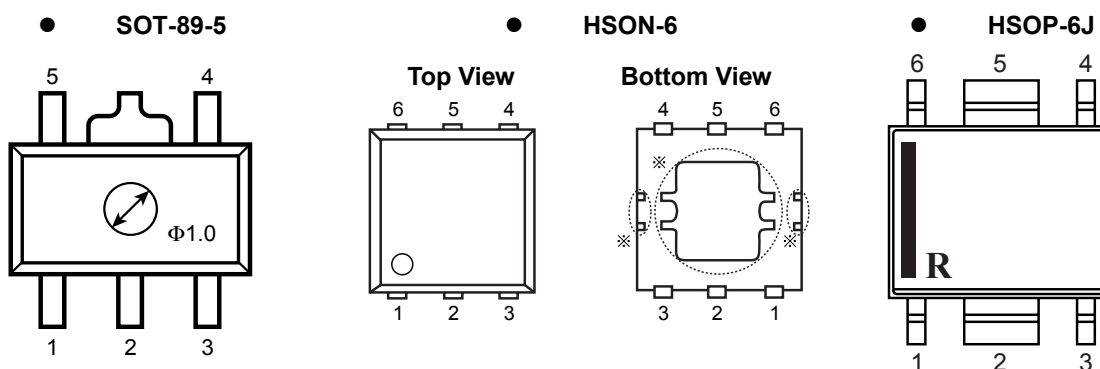

PIN DESCRIPTION

• SOT-89-5

Pin No	Symbol	Description
1	\overline{CE} or CE	Chip Enable Pin
2	GND	Ground Pin
3	NC	No Connection
4	V_{DD}	Input Pin
5	V_{OUT}	Voltage Regulator Output Pin

• HSON-6

Pin No	Symbol	Description
1	V_{OUT}	Voltage Regulator Output Pin
2	V_{OUT}	Voltage Regulator Output Pin
3	\overline{CE} or CE	Chip Enable Pin
4	GND	Ground Pin
5	V_{DD}	Input Pin
6	V_{DD}	Input Pin

* Tab in the  parts have GND level. (They are connected to the reverse side of this IC.)
Do not connect to other wires or land patterns.

• HSOP-6J

Pin No	Symbol	Description
1	V_{OUT}	Voltage Regulator Output Pin
2	GND	Ground Pin
3	\overline{CE} or CE	Chip Enable Pin
4	NC	No Connection
5	GND	Ground Pin
6	V_{DD}	Input Pin

ABSOLUTE MAXIMUM RATINGS

Symbol	Item	Rating	Unit
V_{IN}	Input Voltage	7.0	V
V_{CE}	Input Voltage (\overline{CE} or CE Input Pin)	-0.3 to $V_{IN}+0.3$	V
V_{OUT}	Output Voltage	-0.3 to $V_{IN}+0.3$	V
I_{OUT}	Output Current	1.2	A
P_D	Power Dissipation (SOT-89-5)* ¹	900	mW
	Power Dissipation (HSON-6)* ¹	900	
	Power Dissipation (HSOP-6J)* ¹	1700	
T_{opt}	Operating Temperature	-40 to 85	°C
T_{stg}	Storage Temperature	-55 to 125	°C

*1) For Power Dissipation, please refer to PACKAGE INFORMATION to be described.

ELECTRICAL CHARACTERISTICS

• R1170xxxxA

$T_{opt}=25^{\circ}\text{C}$

Symbol	Item	Conditions	Min.	Typ.	Max.	Unit
V_{IN}	Input Voltage				6.0	V
I_{SS1}	Supply Current1	$V_{IN}-V_{OUT}=1.0\text{V}$, $V_{CE}=\text{GND}$		80	160	μA
$I_{standby}$	Standby Current	$V_{IN}=V_{CE}=6.0\text{V}$		0.1	1.0	μA
V_{OUT}	Output voltage	$V_{IN}-V_{OUT}=1.0\text{V}$ $I_{OUT}=100\text{mA}$	$\times 0.98$		$\times 1.02$	V
I_{OUT1}	Output Current	$V_{IN}-V_{OUT}=1.0\text{V}$	800			mA
$\frac{\Delta V_{OUT}}{\Delta I_{OUT}}$	Load regulation	$V_{IN}-V_{OUT}=1.0\text{V}$ $1\text{mA} \leq I_{OUT} \leq 300\text{mA}$		30	100	mV
V_{DIF}	Dropout Voltage	$I_{OUT}=300\text{mA}$	Refer to Dropout Voltage Table			
$\frac{\Delta V_{OUT}}{\Delta V_{IN}}$	Line regulation	$I_{OUT}=100\text{mA}$ $V_{OUT}+0.5\text{V} \leq V_{IN} \leq 6.0\text{V}$		0.05	0.30	%/V
RR	Ripple Rejection	$f=1\text{kHz}$, Ripple 0.5Vp-p $1.5\text{V} \leq V_{IN} \leq 4.0\text{V}$: $V_{IN}-V_{OUT}=1.0\text{V}$ $4.1\text{V} \leq V_{IN} \leq 5.0\text{V}$: $V_{IN}-V_{OUT}=0.75\text{V}$		50		dB
$\frac{\Delta V_{OUT}}{\Delta T_{opt}}$	Output Voltage Temperature Coefficient	$I_{OUT}=10\text{mA}$ $-40^{\circ}\text{C} \leq T_{opt} \leq 85^{\circ}\text{C}$		± 100		ppm/ $^{\circ}\text{C}$
I_{lim}	Short Current Limit	$V_{OUT}=0\text{V}$		40		mA
R_{PU}	Pull-up resistance for $\overline{\text{CE}}$ pin		1.25	2.50	5.00	$\text{M}\Omega$
V_{CEH}	$\overline{\text{CE}}$ Input Voltage "H"		1.50		V_{IN}	V
V_{CEL}	$\overline{\text{CE}}$ Input Voltage "L"		0.00		0.25	V
T_{TSD}	Thermal Shutdown Detector Threshold Temperature	Junction Temperature		150		$^{\circ}\text{C}$
T_{TSR}	Thermal Shutdown Released Temperature	Junction Temperature		120		$^{\circ}\text{C}$

R1170x

• R1170xxxxB

T_{opt}=25°C

Symbol	Item	Conditions	Min.	Typ.	Max.	Unit
V _{IN}	Input voltage				6.0	V
I _{SS1}	Supply Current1	V _{IN} -V _{OUT} =1.0V, V _{CE} =V _{IN}		80	160	μA
I _{standby}	Standby Current	V _{IN} =6.0V, V _{CE} =GND		0.1	1.0	μA
V _{OUT}	Reference Voltage for Adjustable Voltage Regulator	V _{IN} -V _{OUT} =1.0V I _{OUT} =100mA	×0.98		×1.02	V
I _{OUT1}	Output Current	V _{IN} -V _{OUT} =1.0V	800			mA
ΔV _{OUT} / ΔI _{OUT}	Load regulation	V _{IN} -V _{OUT} =1.0V 1mA ≤ I _{OUT} ≤ 300mA		30	100	mV
V _{DIF}	Dropout Voltage	I _{OUT} =300mA	Refer to Dropout Voltage Table			
ΔV _{OUT} / ΔV _{IN}	Line regulation	I _{OUT} =100mA V _{OUT} +0.5V ≤ V _{IN} ≤ 6.0V		0.05	0.30	%/V
RR	Ripple Rejection	f=1kHz, Ripple 0.5Vp-p 1.5V ≤ V _{IN} ≤ 4.0V: V _{IN} -V _{OUT} =1.0V 4.1V ≤ V _{IN} ≤ 5.0V: V _{IN} -V _{OUT} =0.75V		50		dB
ΔV _{OUT} / ΔT _{opt}	Output Voltage Temperature Coefficient	-40°C ≤ T _{opt} ≤ 85°C		±100		ppm/°C
I _{lim}	Short Current Limit	V _{OUT} =0V		40		mA
R _{PD}	Pull-down resistance for CE pin		1.25	2.50	5.00	MΩ
V _{CEH}	CE Input Voltage "H"		1.5		V _{IN}	V
V _{CEL}	CE Input Voltage "L"		0.00		0.25	V
T _{TSD}	Thermal Shutdown Detector Threshold Temperature	Junction Temperature		150		°C
T _{TSR}	Thermal Shutdown Released Temperature	Junction Temperature		120		°C

• Dropout Voltage by Output Voltage (T_{opt}=25°C)

Output Voltage V _{OUT} (V)	Dropout Voltage V _{DIF} (V)	
	Typ.	Max.
V _{OUT} =1.5	0.35	0.45
V _{OUT} =1.6	0.30	0.35
V _{OUT} =1.7	0.25	0.30
1.8 ≤ V _{OUT} ≤ 2.0	0.20	0.25
2.1 ≤ V _{OUT} ≤ 2.4	0.15	0.20
2.5 ≤ V _{OUT} ≤ 5.0	0.12	0.18

TEST CIRCUITS

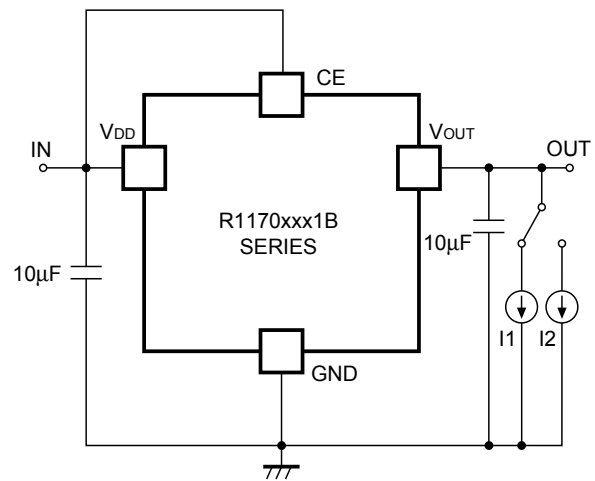
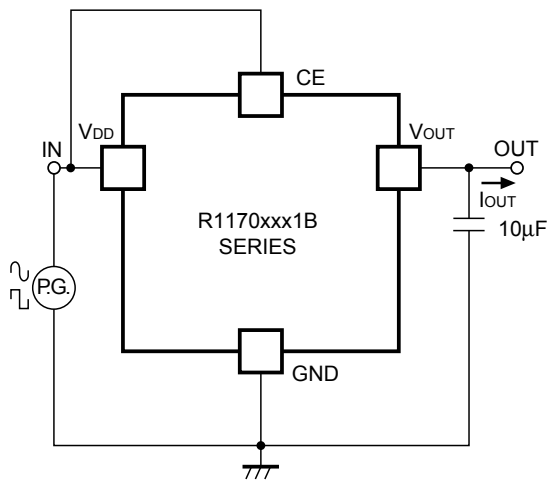
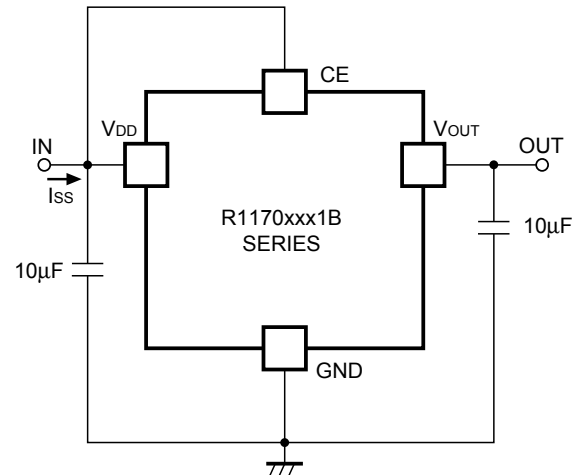
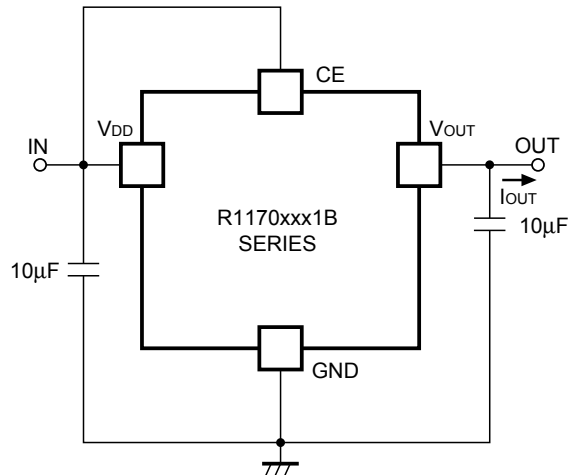

Technical Notes on External Components and Typical Application

Phase Compensation

In these ICs, phase compensation is made with the output capacitor for securing stable operation even if the load current is varied. For this purpose, use as much as 10 μ F Capacitor as C_L .

If you use a tantalum type capacitor and ESR value of the capacitor is large, output might be unstable. Evaluate your circuit with considering frequency characteristics. Further, refer to the Typical Characteristics No. 12.

Mounting on PCB

Make V_{DD} and GND lines sufficient. If their impedance is high, a current flows, the noise picked up or unstable operation may result. Further use as much as 10 μ F capacitor between V_{DD} pin and GND pin as close as possible.

Set an Output capacitor between V_{OUT} pin and GND pin for phase compensation as close as possible.
(Refer to the example of typical application)

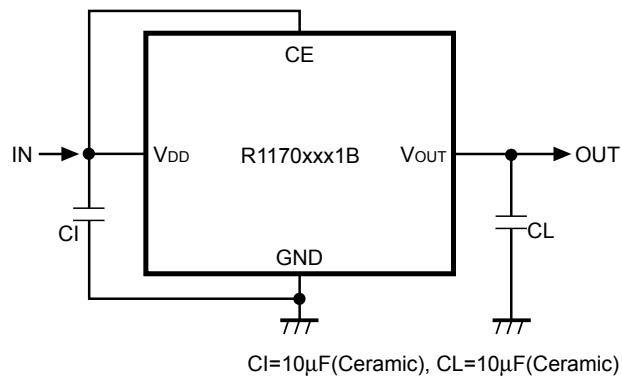

Example of the typical application of R1170xxxxB

TYPICAL CHARACTERISTICS

1) Output Voltage vs. Output Current (T_{opt}=25°C)

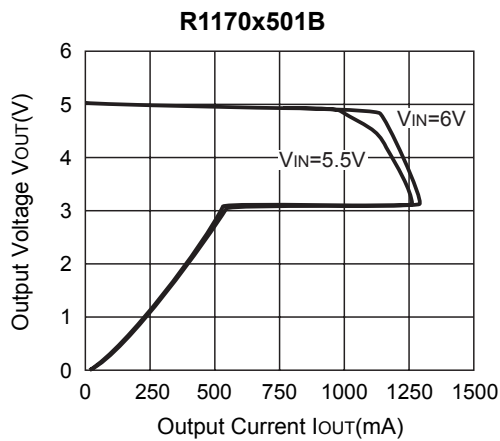
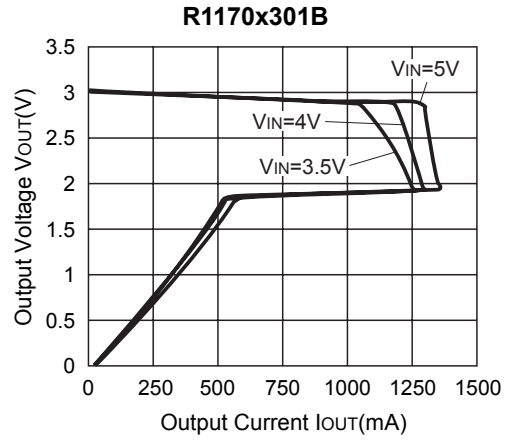
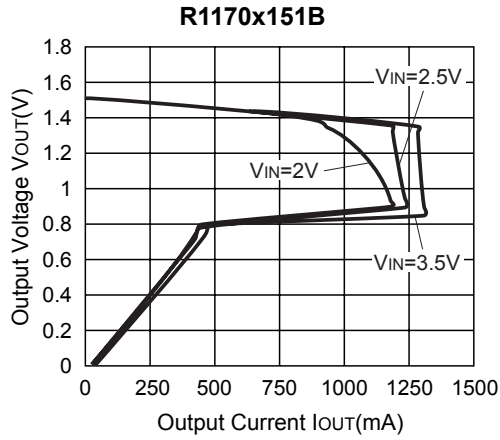

2) Output Voltage vs. Input Voltage (T_{opt}=25°C)

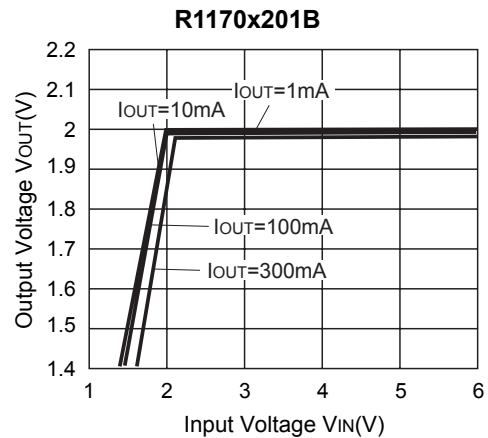
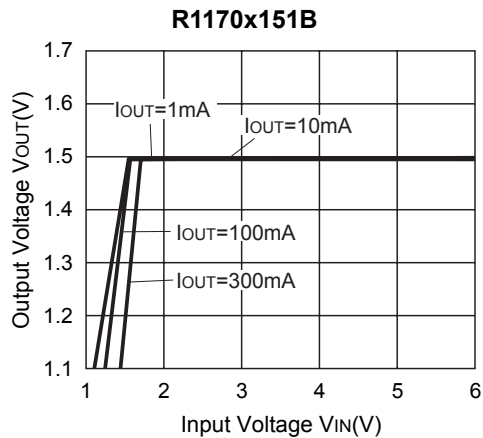

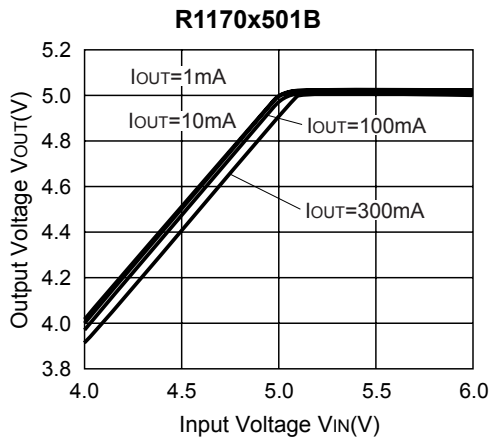
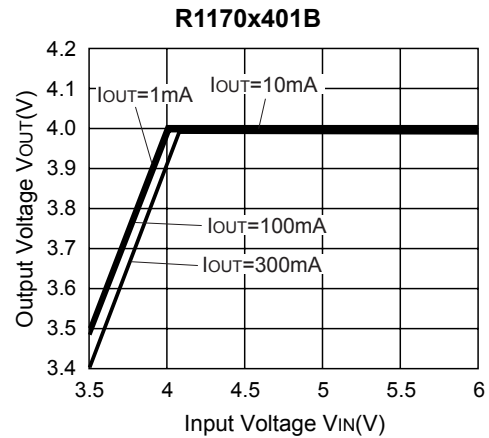
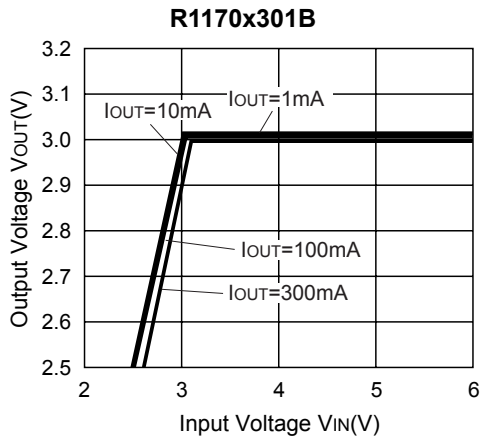

3) Dropout Voltage vs. Output Current

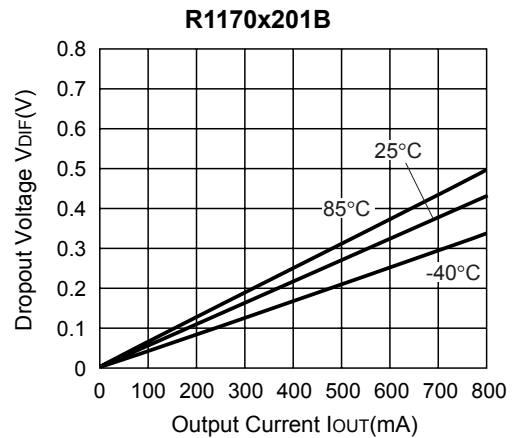
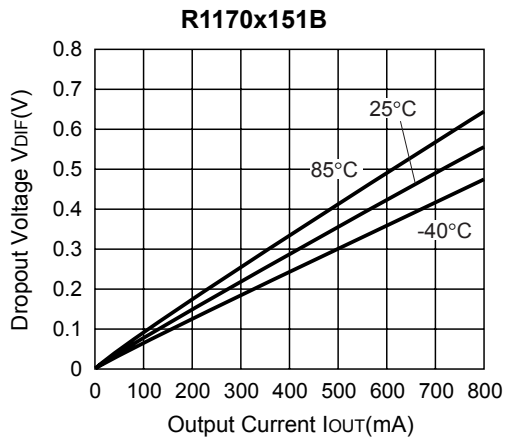

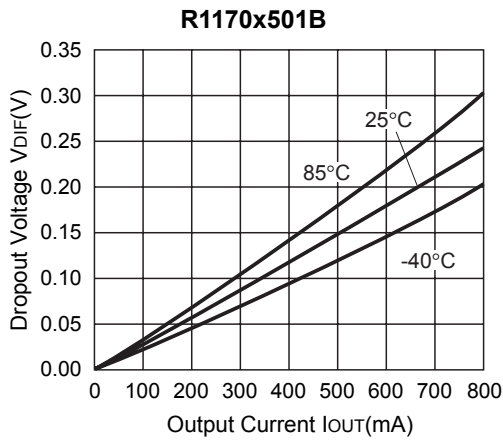
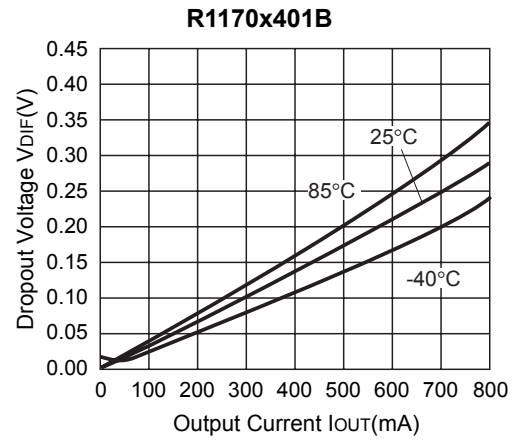
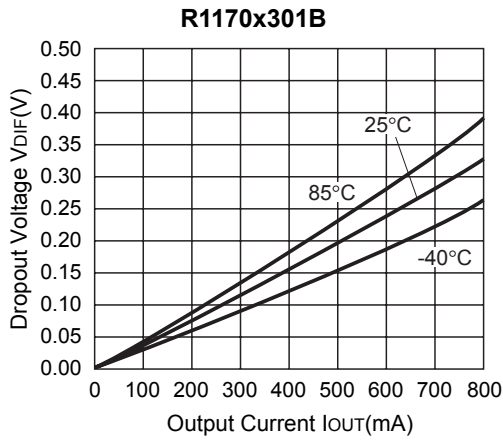

4) Output Voltage vs. Temperature

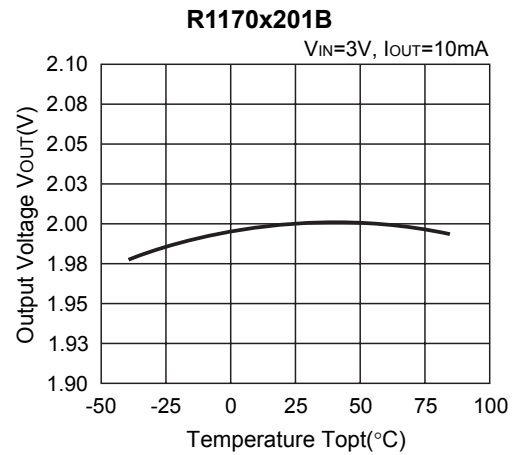
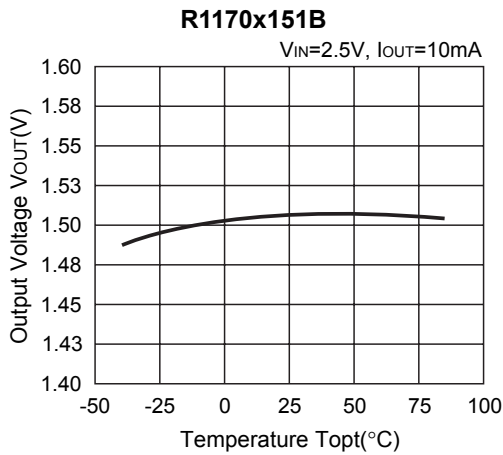

R1170x

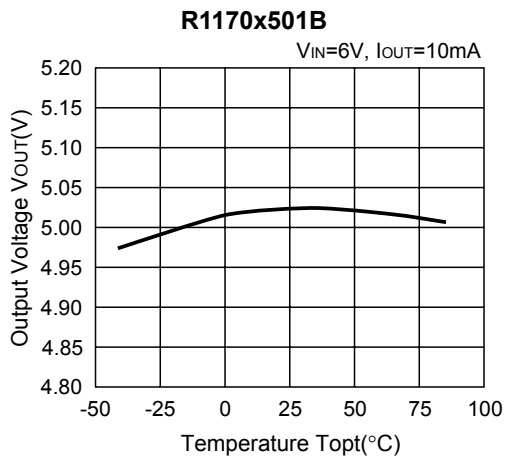
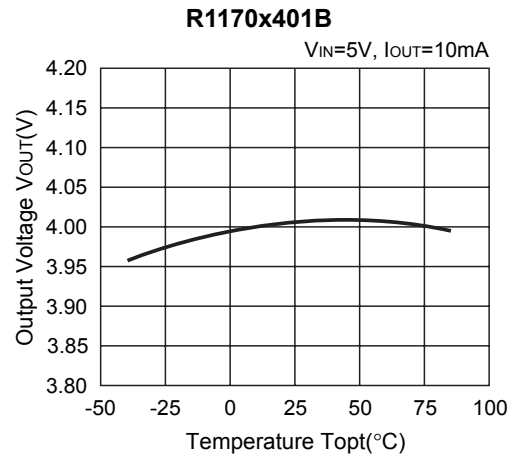
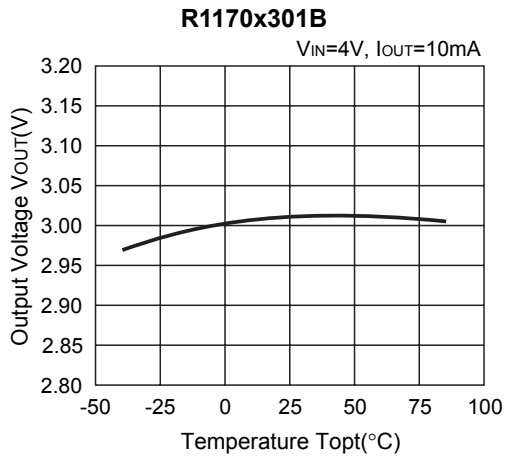

5) Supply Current vs. Input Voltage ($T_{opt}=25^{\circ}C$)

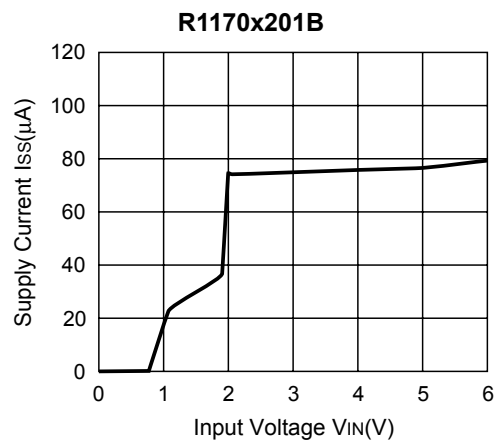
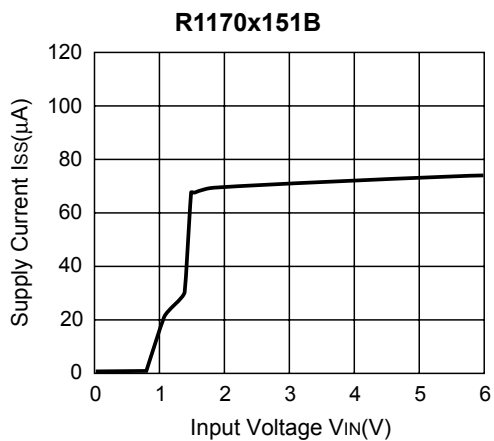

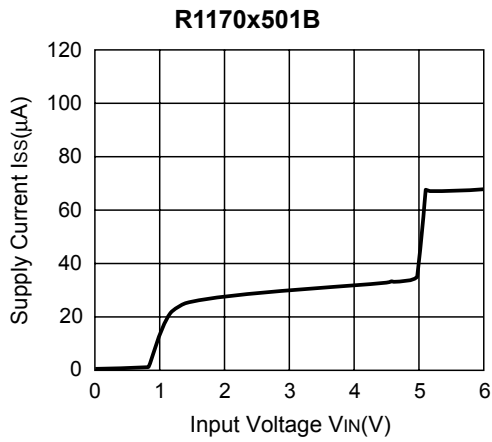
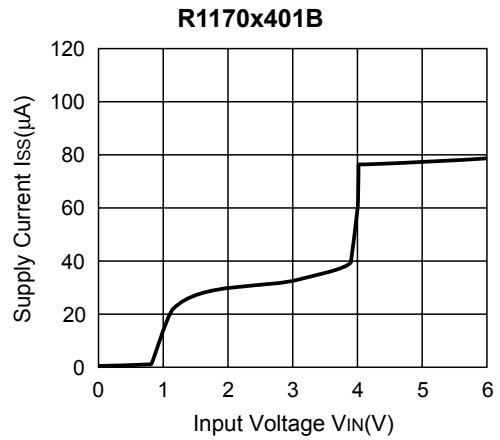
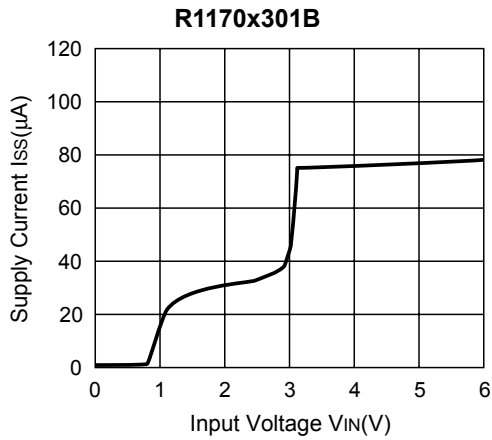

6) Supply Current vs. Temperature

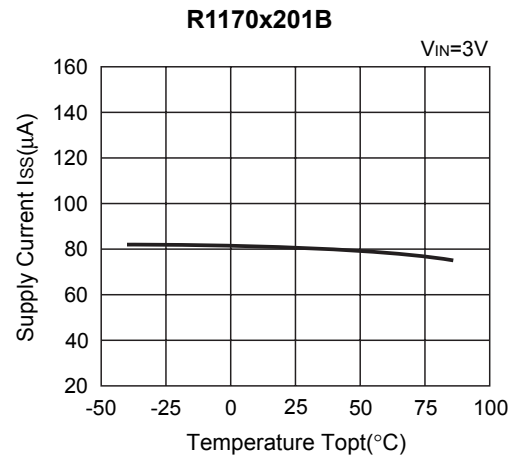
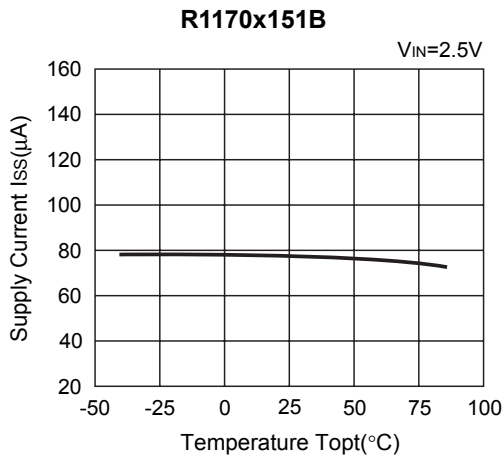

R1170x

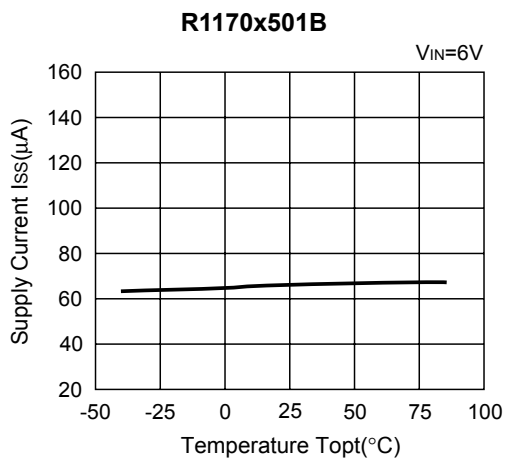
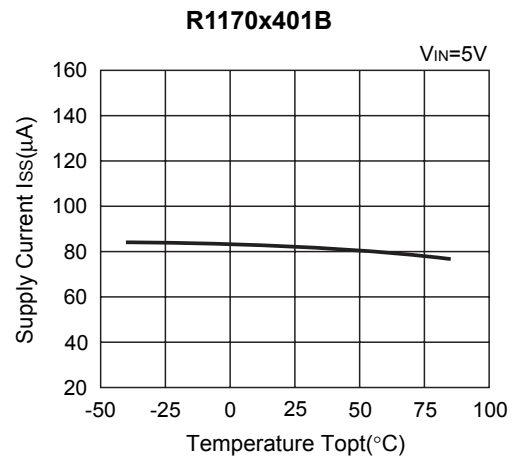
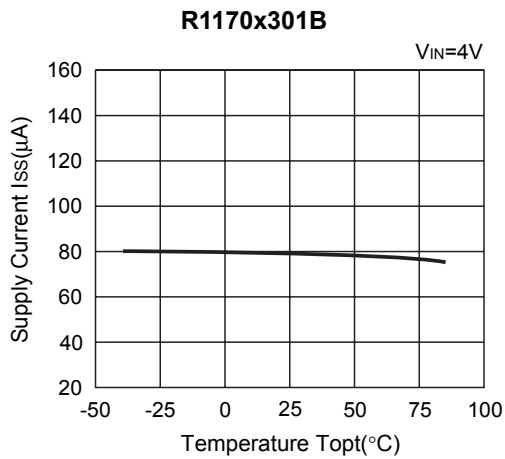

7) Dropout Voltage vs. Set Output Voltage ($T_{opt}=25^{\circ}C$)

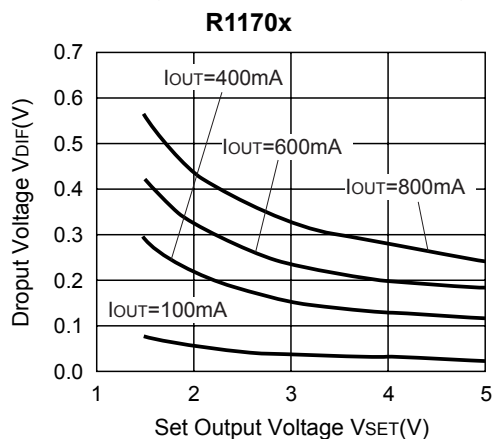

8) Ripple Rejection vs. Frequency

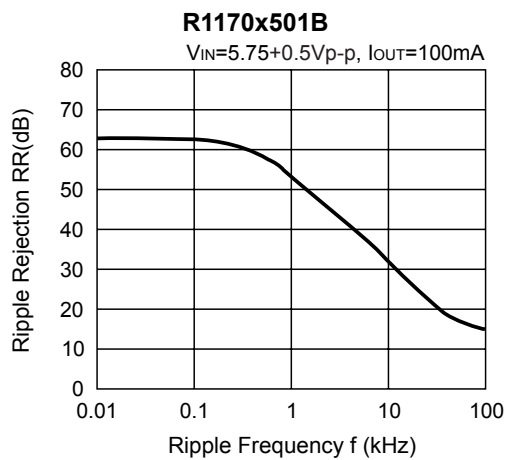
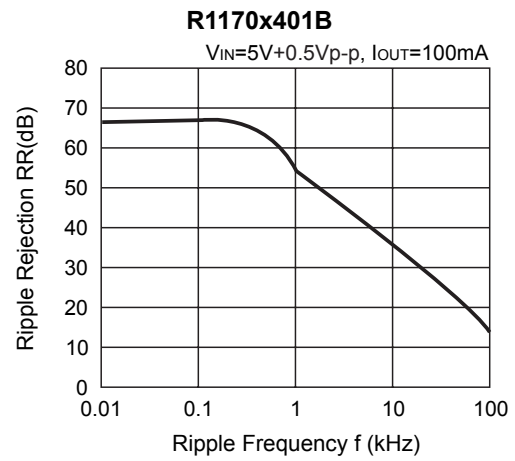
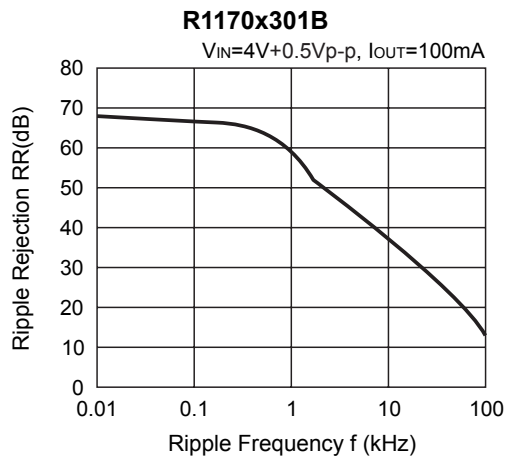
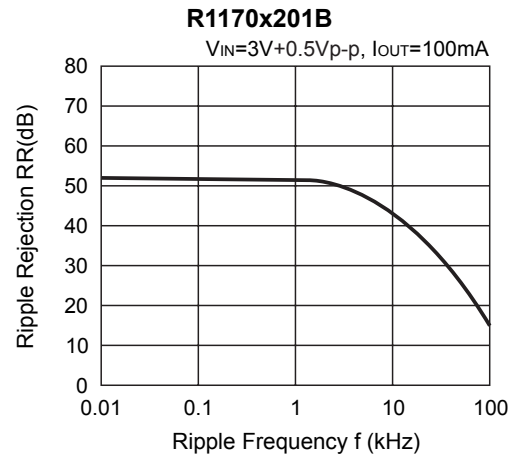
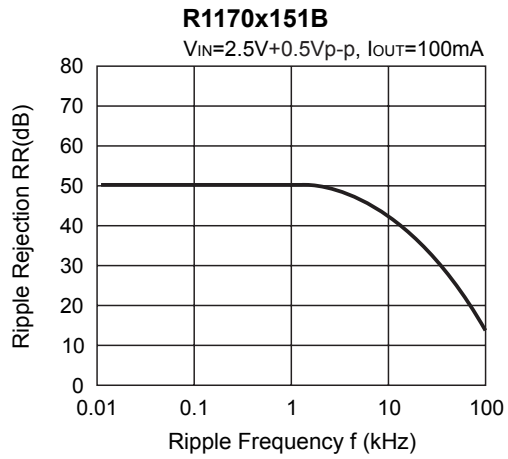

9) Ripple Rejection vs. Input Voltage

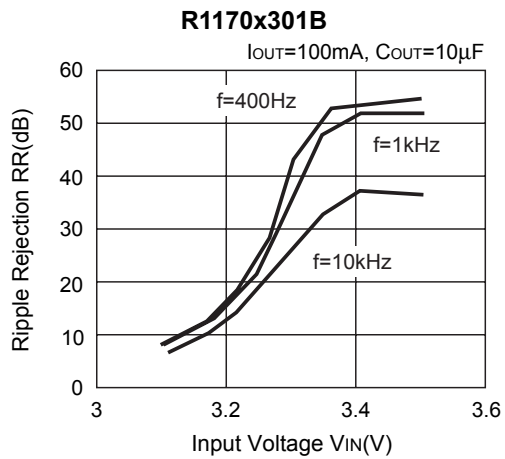
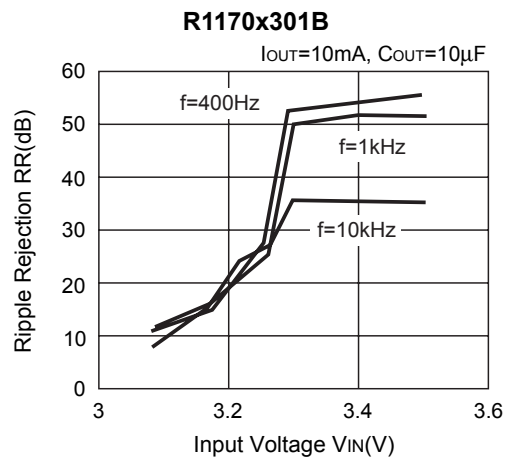
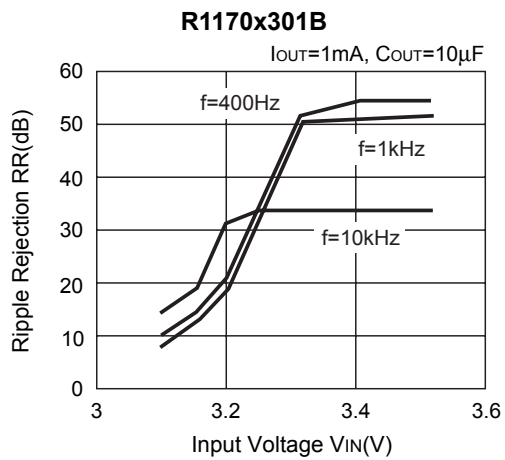

10) Input Transient Response ($T_{opt}=25^{\circ}C$)

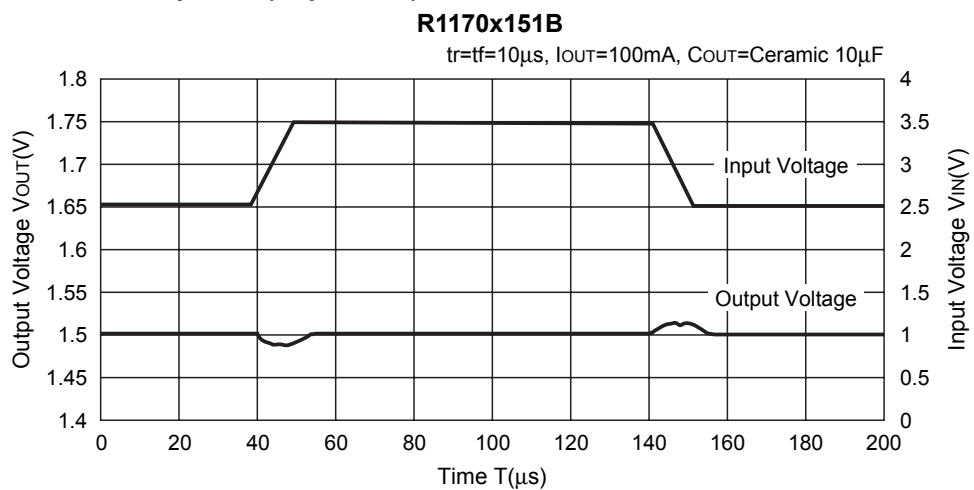

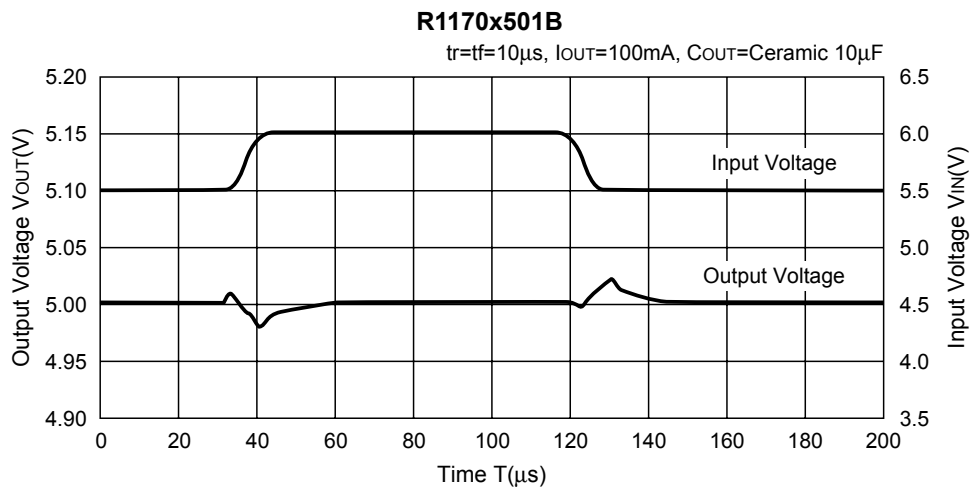
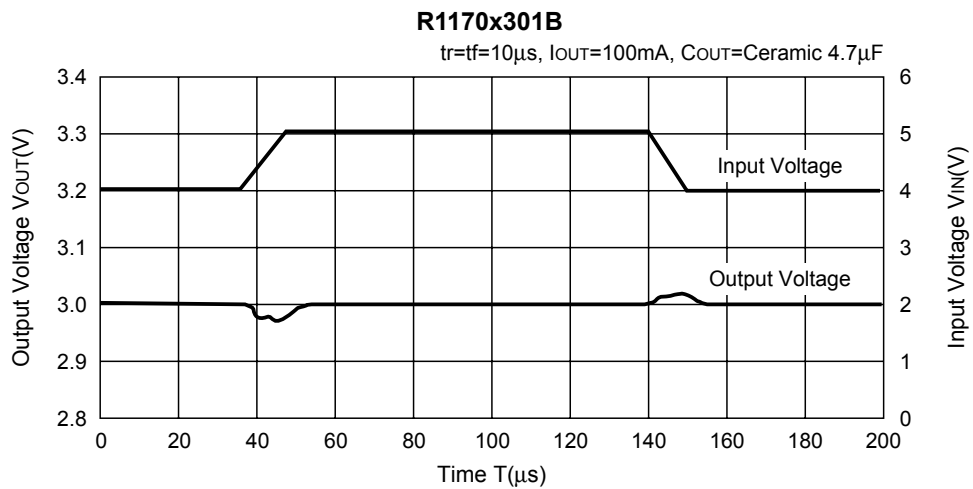
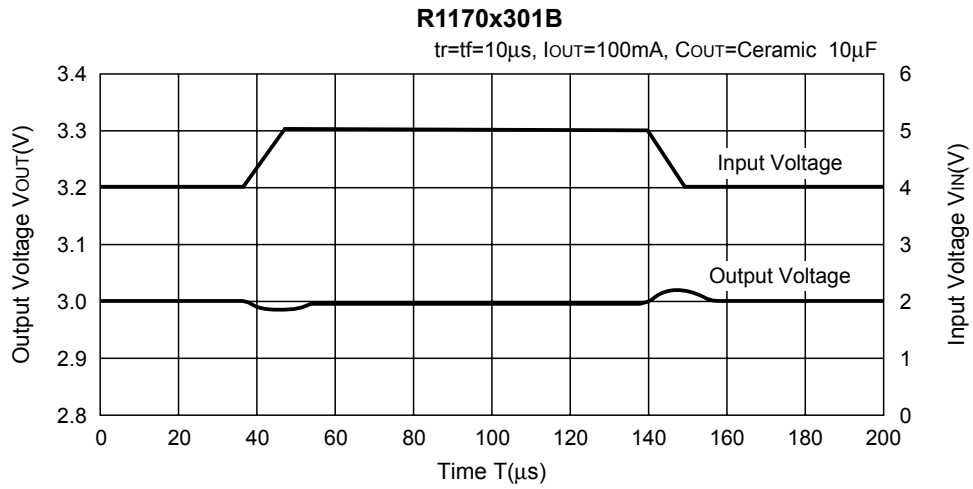

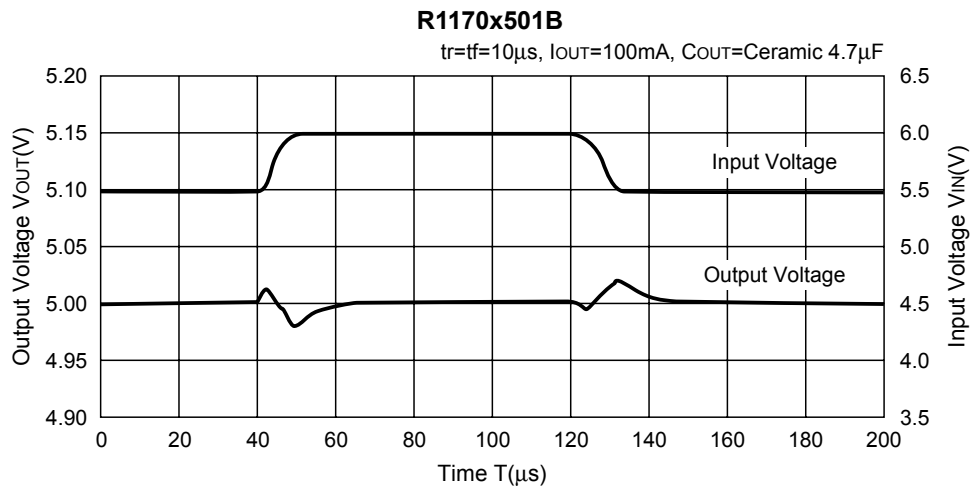

11) Load Transient Response ($T_{opt}=25^{\circ}C$)

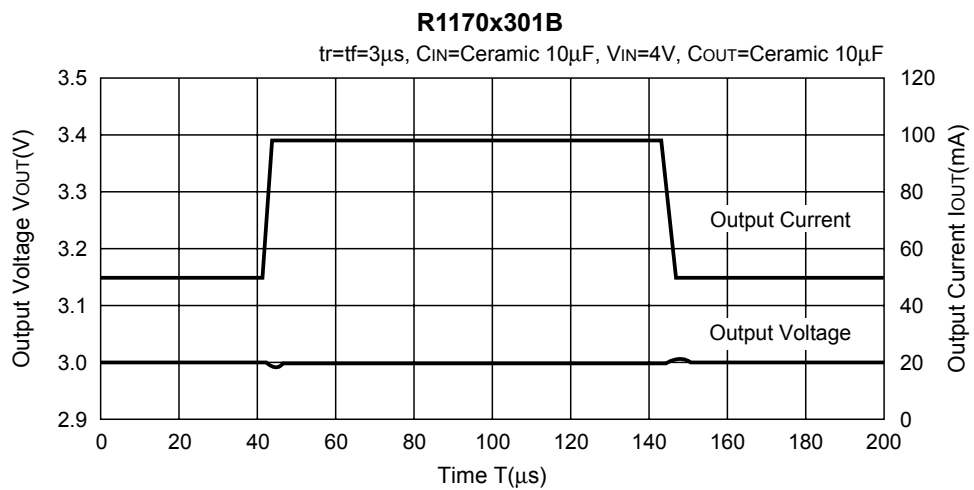
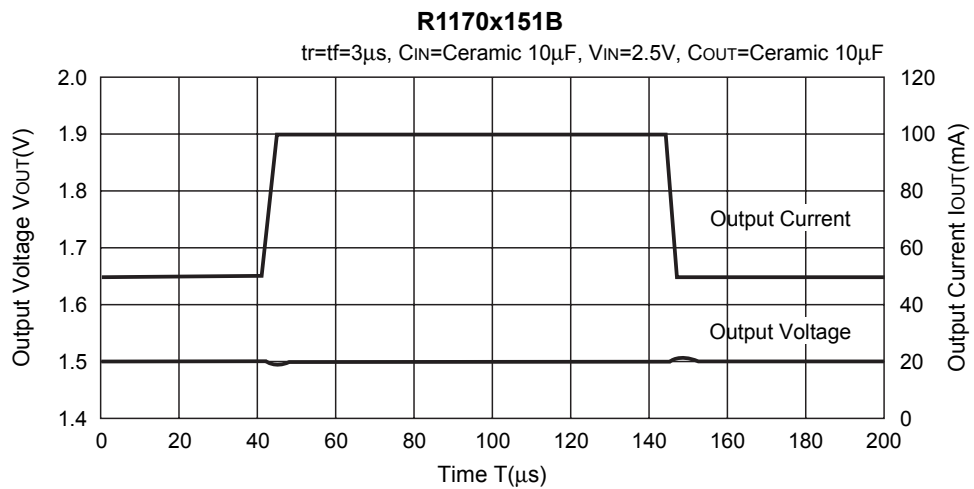

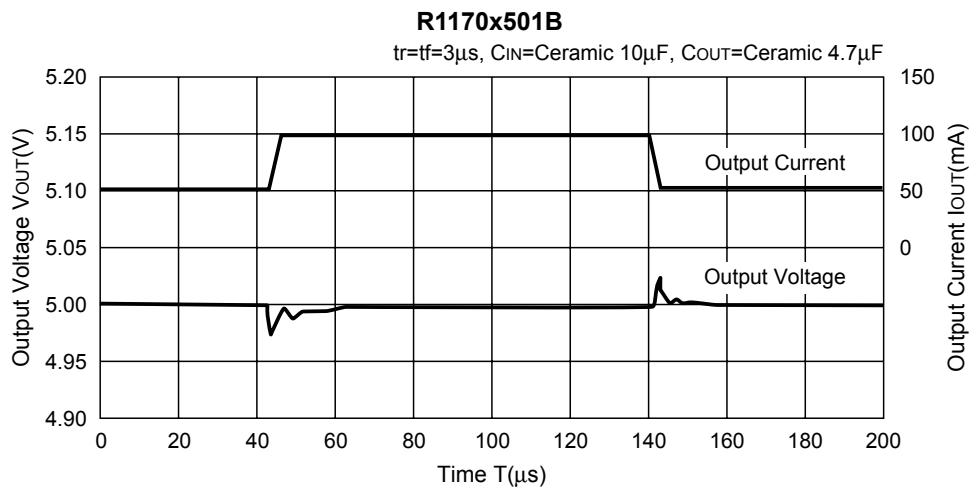
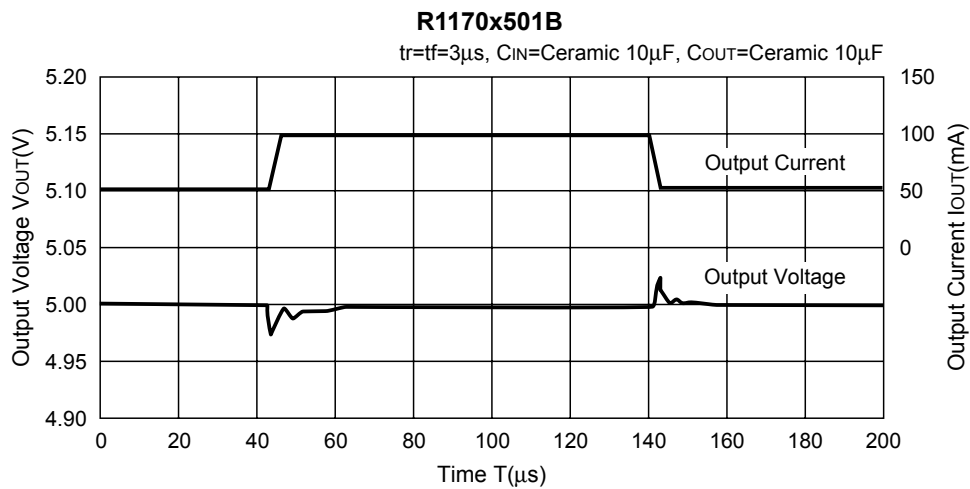
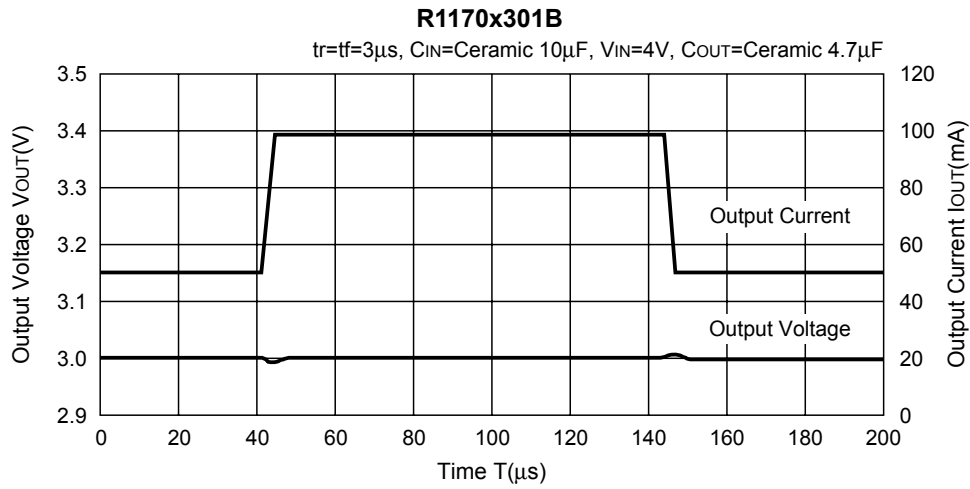

12) Stable Area (Topt=25°C, VIN = Set Output Voltage+1V, CIN = Ceramic 10µF)

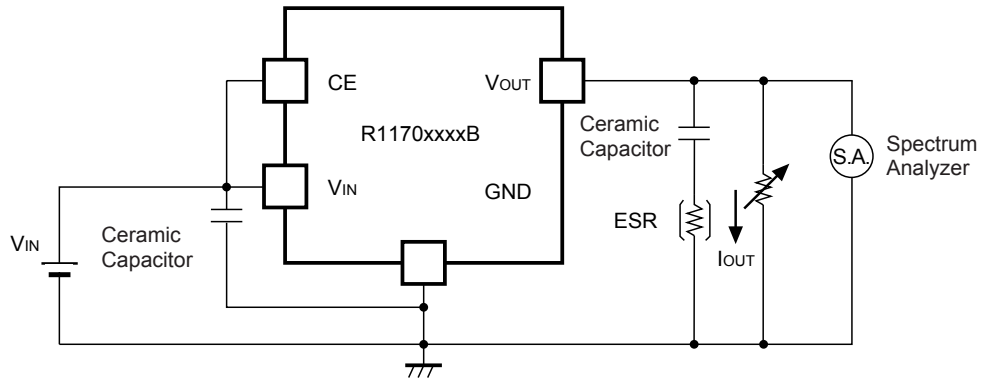

As an output capacitor for this IC, Ceramic capacitor is recommendable. However, other low ESR type capacitor can be used with this IC.

For your reference, noise level is tested with the circuit as shown above, and if the noise level is 40µV or less than 40µV, the ESR values are plotted as stable area. Upper limit is described in the next four graphs, or ESR vs. Output Current. (Hatched area is the stable area.)

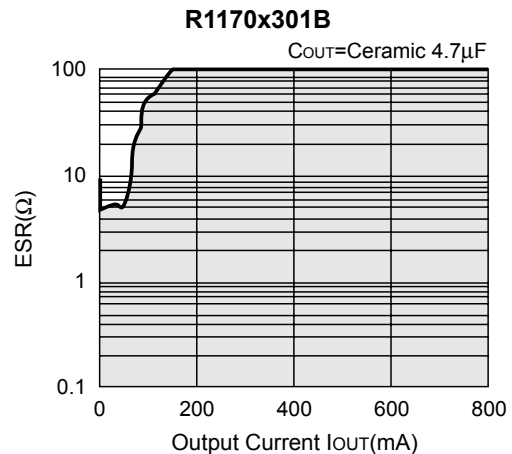
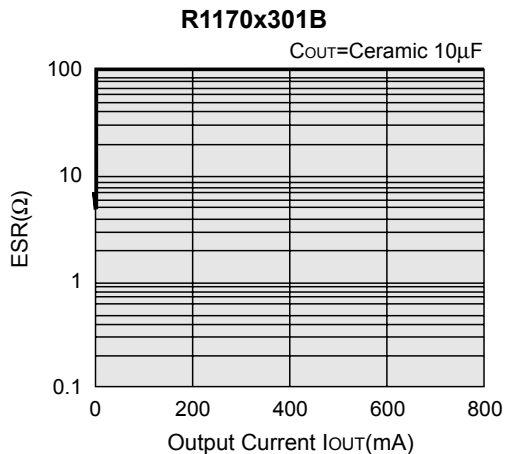
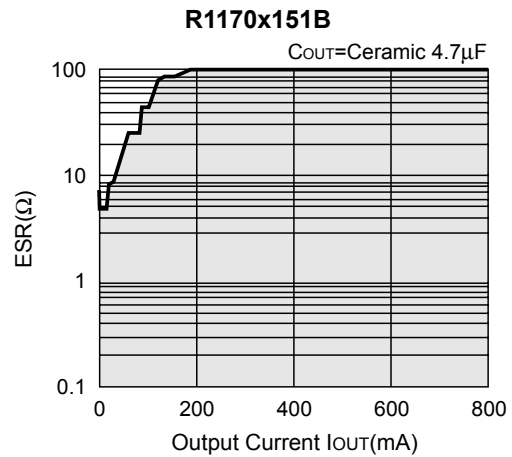
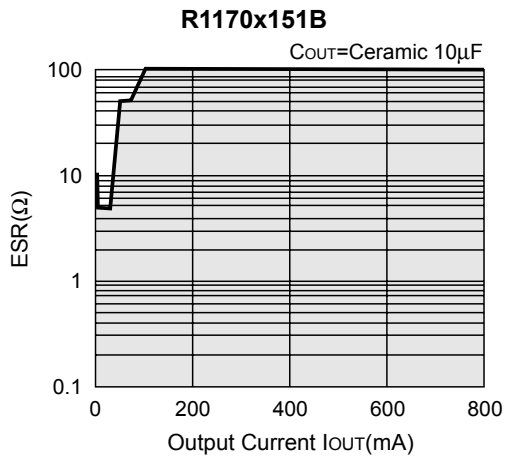

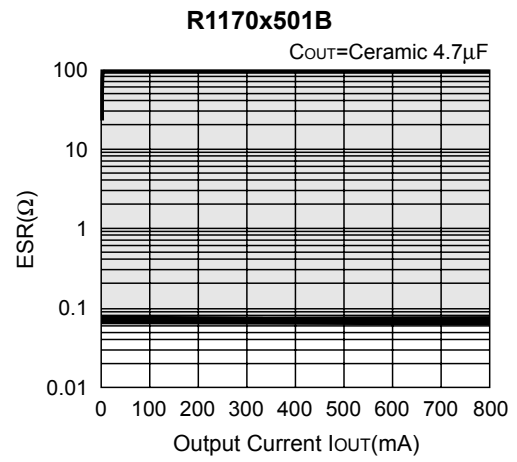
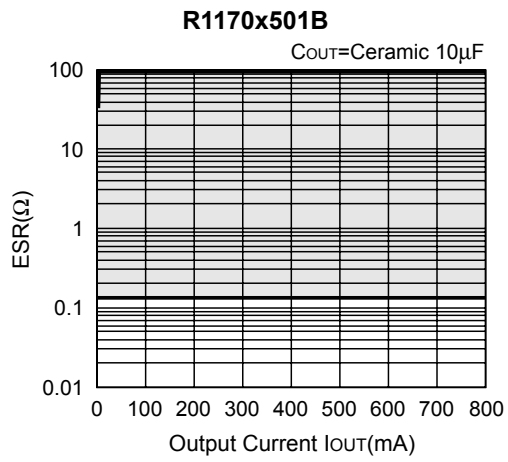

• SOT-89-5

Unit: mm

PACKAGE DIMENSIONS

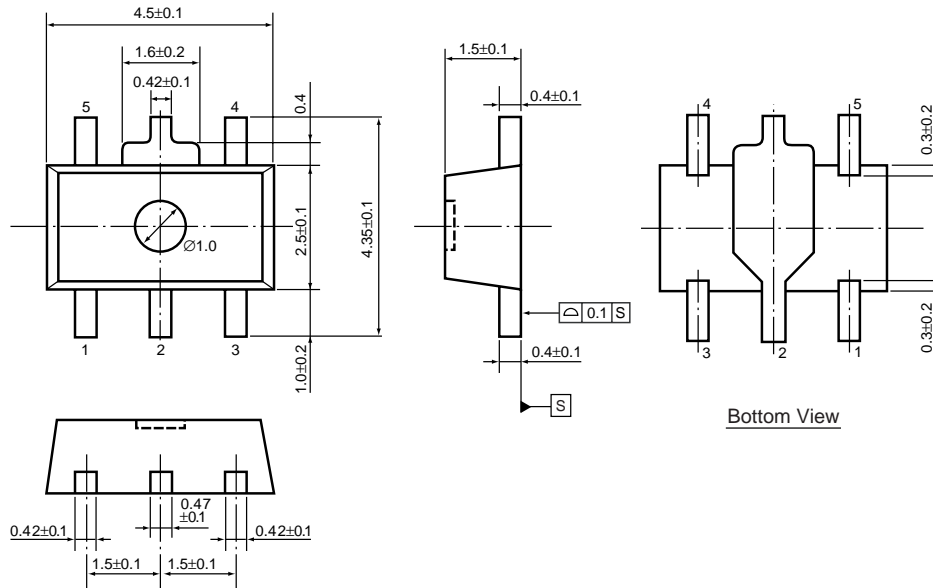

TAPING SPECIFICATION (T1: Standard Type)

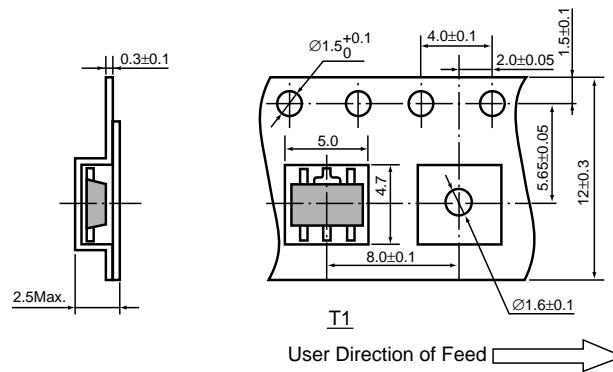

TAPING REEL DIMENSIONS REUSE REEL (EIAJ-RRM-12Bc)

(1reel=1000pcs)

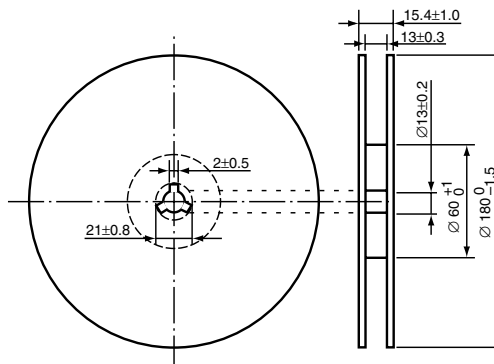

POWER DISSIPATION (SOT-89-5)

This specification is at mounted on board. Power Dissipation (P_D) depends on conditions of mounting on board. This specification is based on the measurement at the condition below:

Measurement Conditions

	High Wattage Land Pattern	Standard Land Pattern
Environment	Mounting on Board (Wind velocity=0m/s)	Mounting on Board (Wind velocity=0m/s)
Board Material	Glass cloth epoxy plastic (Double sided)	Glass cloth epoxy plastic (Double sided)
Board Dimensions	30mm × 30mm × 1.6mm	50mm × 50mm × 1.6mm
Copper Ratio	Top side : Approx. 20% , Back side : Approx. 100%	Top side : Approx. 10% , Back side : Approx. 100%
Through-hole	φ0.85mm × 10pcs	-

Measurement Result

($T_{opt}=25^{\circ}C, T_{jmax}=125^{\circ}C$)

	High Wattage Land Pattern	Standard Land Pattern	Free Air
Power Dissipation	1300mW	900mW	500mW
Thermal Resistance	77°C/W	111°C/W	200°C/W

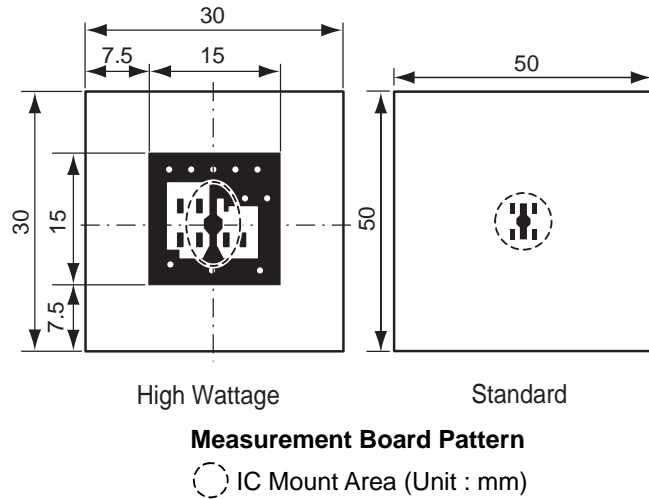
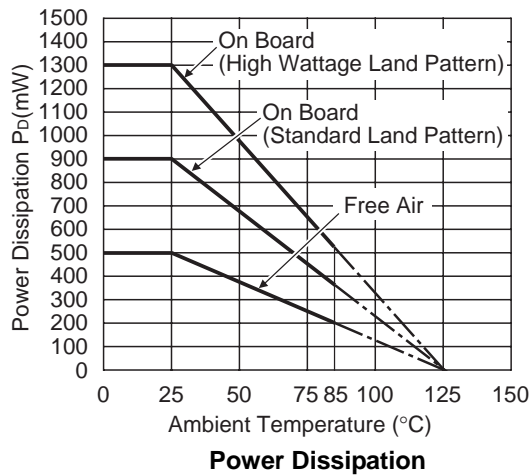

RECOMMENDED LAND PATTERN (SOT-89-5)

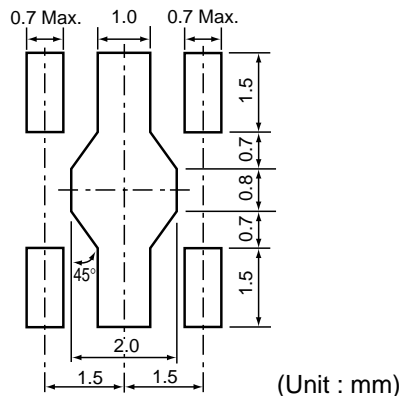

• HSON-6

Unit: mm

PACKAGE DIMENSIONS

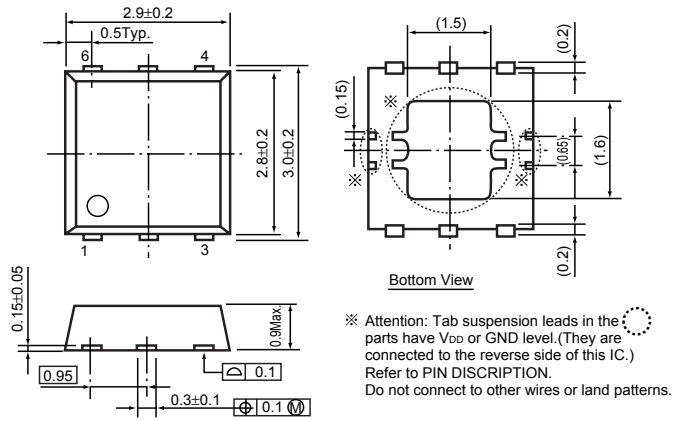

TAPING SPECIFICATION

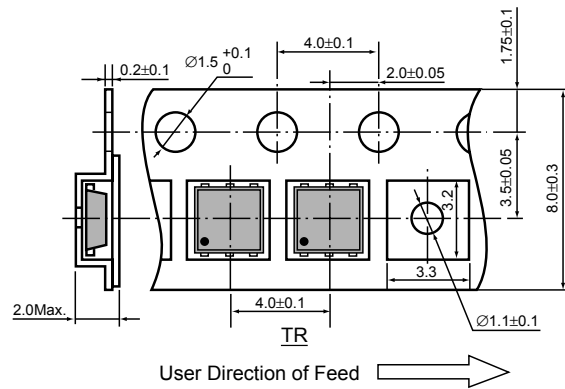

TAPING REEL DIMENSIONS REUSE REEL (EIAJ-RRM-08Bc)

(1reel=3000pcs)

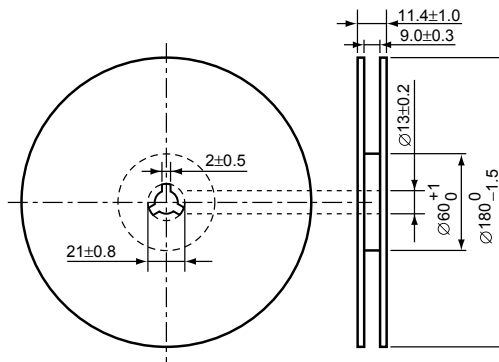

POWER DISSIPATION (HSON-6)

This specification is at mounted on board. Power Dissipation (P_D) depends on conditions of mounting on board. This specification is based on the measurement at the condition below:

Measurement Conditions

	Standard Land Pattern
Environment	Mounting on Board (Wind velocity=0m/s)
Board Material	Glass cloth epoxy plactic (Double sided)
Board Dimensions	40mm × 40mm × 1.6mm
Copper Ratio	Top side : Approx. 50% , Back side : Approx. 50%
Through-hole	φ0.5mm × 44pcs

Measurement Result

($T_{opt}=25^{\circ}C, T_{jmax}=125^{\circ}C$)

	Standard Land Pattern	Free Air
Power Dissipation	900mW	400mW
Thermal Resistance	$\theta_{ja}=(125-25^{\circ}C)/0.9W=111^{\circ}C/W$	250 $^{\circ}C/W$

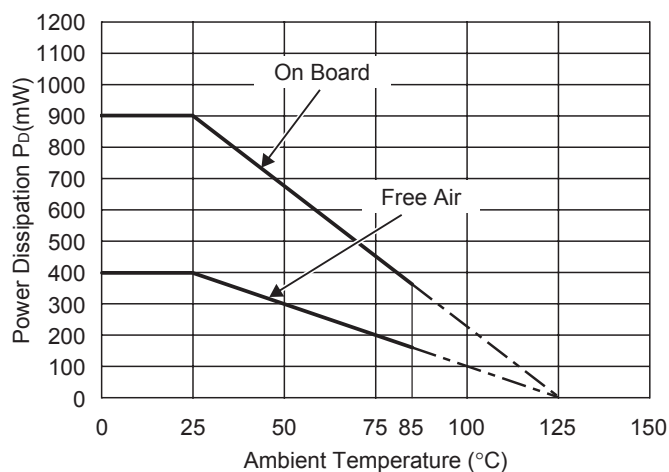

Power Dissipation

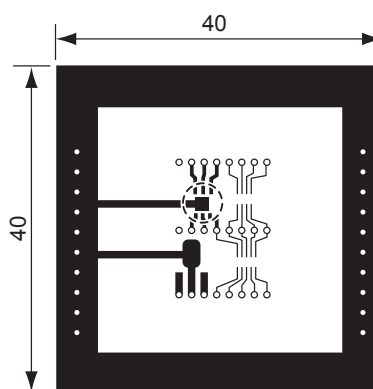

Measurement Board Pattern

○ IC Mount Area Unit : mm

RECOMMENDED LAND PATTERN

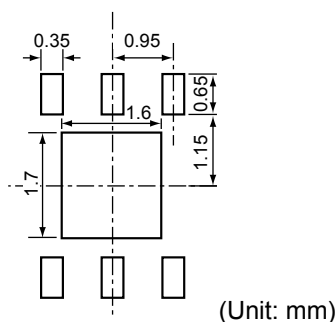

• HSOP-6J

Unit: mm

PACKAGE DIMENSIONS

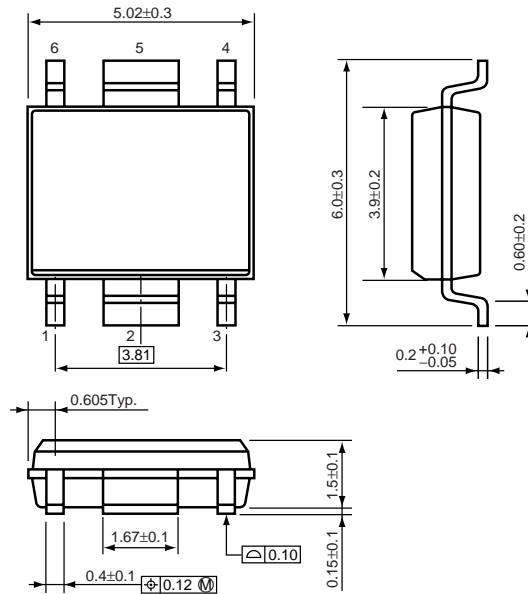

TAPING SPECIFICATION

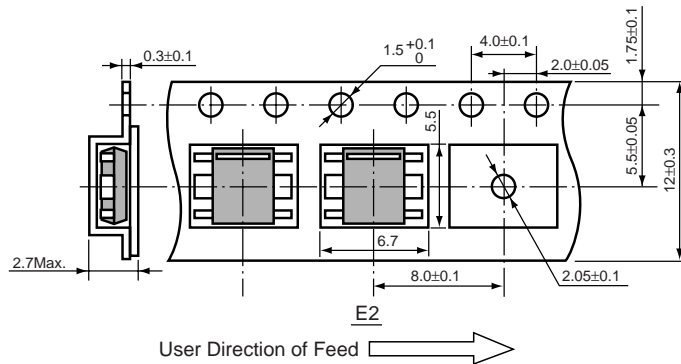

TAPING REEL DIMENSIONS REUSE REEL (EIAJ-RRM-12Bc)

(1reel=1000pcs)

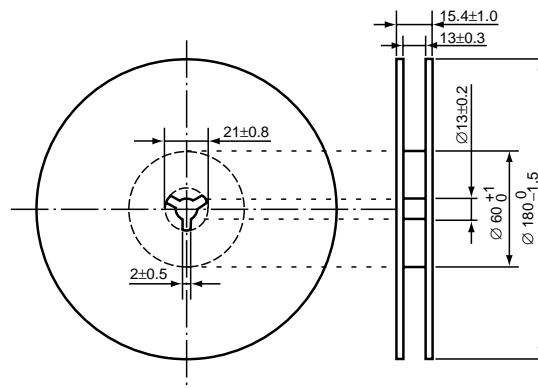

POWER DISSIPATION (HSOP-6J)

This specification is at mounted on board. Power Dissipation (P_D) depends on conditions of mounting on board. This specification is based on the measurement at the condition below:

Measurement Conditions

	High Wattage Land Pattern	Standard Land Pattern
Environment	Mounting on Board (Wind velocity=0m/s)	Mounting on Board (Wind velocity=0m/s)
Board Material	Glass cloth epoxy plactic (Double sided)	Glass cloth epoxy plactic (Double sided)
Board Dimensions	50mm × 50mm × 1.6mm	50mm × 50mm × 1.6mm
Copper Ratio	90%	50%
Through-hole	φ0.5mm × 44pcs	φ0.5mm × 44pcs

Measurement Result

($T_{opt}=25^{\circ}C, T_{jmax}=125^{\circ}C$)

	High Wattage Land Pattern	Standard Land Pattern	Free Air
Power Dissipation	2000mW	1700mW	540mW
Thermal Resistance	50°C/W	59°C/W	185°C/W

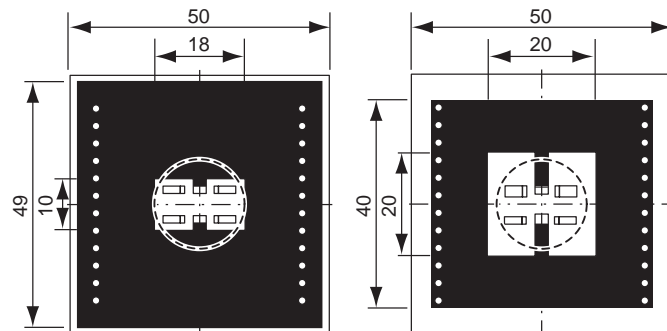
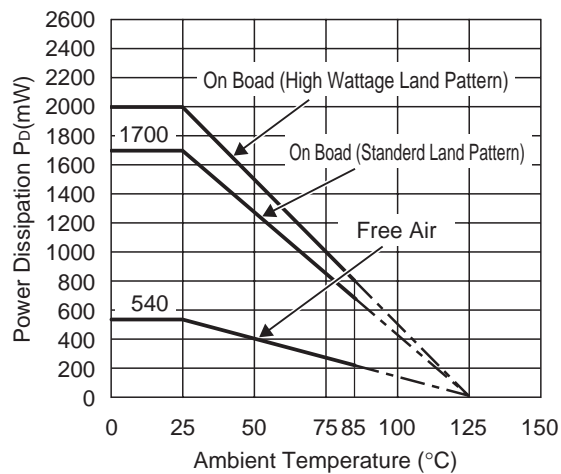

High Wattage Standard Measurement Board Pattern

○ IC Mount Area Unit : mm

RECOMMENDED LAND PATTERN (HSOP-6J)

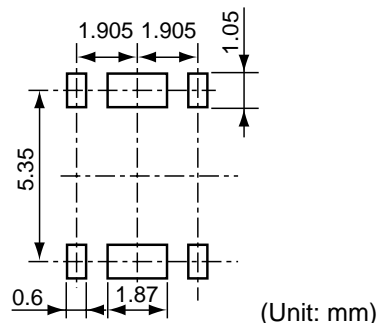

R1170H SERIES MARK SPECIFICATION

• SOT-89-5

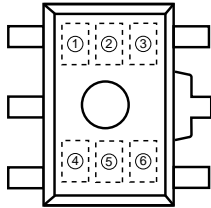

- ① : E (fixed)
- ②, ③ : Setting Voltage } (refer to Part Number vs. Product Code)
- ④ : Type (A or B)
- ⑤, ⑥ : Lot Number

• Part Number vs. Product Code

Part Number	Product Code			
	①	②	③	④
R1170H151A	E	1	5	A
R1170H161A	E	1	6	A
R1170H171A	E	1	7	A
R1170H181A	E	1	8	A
R1170H191A	E	1	9	A
R1170H201A	E	2	0	A
R1170H211A	E	2	1	A
R1170H221A	E	2	2	A
R1170H231A	E	2	3	A
R1170H241A	E	2	4	A
R1170H251A	E	2	5	A
R1170H261A	E	2	6	A
R1170H271A	E	2	7	A
R1170H281A	E	2	8	A
R1170H291A	E	2	9	A
R1170H301A	E	3	0	A
R1170H311A	E	3	1	A
R1170H321A	E	3	2	A

Part Number	Product Code			
	①	②	③	④
R1170H331A	E	3	3	A
R1170H341A	E	3	4	A
R1170H351A	E	3	5	A
R1170H361A	E	3	6	A
R1170H371A	E	3	7	A
R1170H381A	E	3	8	A
R1170H391A	E	3	9	A
R1170H401A	E	4	0	A
R1170H411A	E	4	1	A
R1170H421A	E	4	2	A
R1170H431A	E	4	3	A
R1170H441A	E	4	4	A
R1170H451A	E	4	5	A
R1170H461A	E	4	6	A
R1170H471A	E	4	7	A
R1170H481A	E	4	8	A
R1170H491A	E	4	9	A
R1170H501A	E	5	0	A

Part Number	Product Code			
	①	②	③	④
R1170H151B	E	1	5	B
R1170H161B	E	1	6	B
R1170H171B	E	1	7	B
R1170H181B	E	1	8	B
R1170H191B	E	1	9	B
R1170H201B	E	2	0	B
R1170H211B	E	2	1	B
R1170H221B	E	2	2	B
R1170H231B	E	2	3	B
R1170H241B	E	2	4	B
R1170H251B	E	2	5	B
R1170H261B	E	2	6	B
R1170H271B	E	2	7	B
R1170H281B	E	2	8	B
R1170H291B	E	2	9	B
R1170H301B	E	3	0	B
R1170H311B	E	3	1	B
R1170H321B	E	3	2	B

Part Number	Product Code			
	①	②	③	④
R1170H331B	E	3	3	B
R1170H341B	E	3	4	B
R1170H351B	E	3	5	B
R1170H361B	E	3	6	B
R1170H371B	E	3	7	B
R1170H381B	E	3	8	B
R1170H391B	E	3	9	B
R1170H401B	E	4	0	B
R1170H411B	E	4	1	B
R1170H421B	E	4	2	B
R1170H431B	E	4	3	B
R1170H441B	E	4	4	B
R1170H451B	E	4	5	B
R1170H461B	E	4	6	B
R1170H471B	E	4	7	B
R1170H481B	E	4	8	B
R1170H491B	E	4	9	B
R1170H501B	E	5	0	B

R1170D SERIES MARK SPECIFICATION

● HSON-6

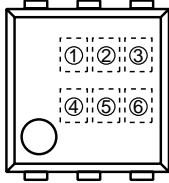

- ① : E (fixed)
- ②, ③ : Setting Voltage } (refer to Part Number vs. Product Code)
- ④ : Type (A or B)
- ⑤, ⑥ : Lot Number

● Part Number vs. Product Code

Part Number	Product Code			
	①	②	③	④
R1170D151A	E	1	5	A
R1170D161A	E	1	6	A
R1170D171A	E	1	7	A
R1170D181A	E	1	8	A
R1170D191A	E	1	9	A
R1170D201A	E	2	0	A
R1170D211A	E	2	1	A
R1170D221A	E	2	2	A
R1170D231A	E	2	3	A
R1170D241A	E	2	4	A
R1170D251A	E	2	5	A
R1170D261A	E	2	6	A
R1170D271A	E	2	7	A
R1170D281A	E	2	8	A
R1170D291A	E	2	9	A
R1170D301A	E	3	0	A
R1170D311A	E	3	1	A
R1170D321A	E	3	2	A

Part Number	Product Code			
	①	②	③	④
R1170D331A	E	3	3	A
R1170D341A	E	3	4	A
R1170D351A	E	3	5	A
R1170D361A	E	3	6	A
R1170D371A	E	3	7	A
R1170D381A	E	3	8	A
R1170D391A	E	3	9	A
R1170D401A	E	4	0	A
R1170D411A	E	4	1	A
R1170D421A	E	4	2	A
R1170D431A	E	4	3	A
R1170D441A	E	4	4	A
R1170D451A	E	4	5	A
R1170D461A	E	4	6	A
R1170D471A	E	4	7	A
R1170D481A	E	4	8	A
R1170D491A	E	4	9	A
R1170D501A	E	5	0	A

Part Number	Product Code			
	①	②	③	④
R1170D151B	E	1	5	B
R1170D161B	E	1	6	B
R1170D171B	E	1	7	B
R1170D181B	E	1	8	B
R1170D191B	E	1	9	B
R1170D201B	E	2	0	B
R1170D211B	E	2	1	B
R1170D221B	E	2	2	B
R1170D231B	E	2	3	B
R1170D241B	E	2	4	B
R1170D251B	E	2	5	B
R1170D261B	E	2	6	B
R1170D271B	E	2	7	B
R1170D281B	E	2	8	B
R1170D291B	E	2	9	B
R1170D301B	E	3	0	B
R1170D311B	E	3	1	B
R1170D321B	E	3	2	B

Part Number	Product Code			
	①	②	③	④
R1170D331B	E	3	3	B
R1170D341B	E	3	4	B
R1170D351B	E	3	5	B
R1170D361B	E	3	6	B
R1170D371B	E	3	7	B
R1170D381B	E	3	8	B
R1170D391B	E	3	9	B
R1170D401B	E	4	0	B
R1170D411B	E	4	1	B
R1170D421B	E	4	2	B
R1170D431B	E	4	3	B
R1170D441B	E	4	4	B
R1170D451B	E	4	5	B
R1170D461B	E	4	6	B
R1170D471B	E	4	7	B
R1170D481B	E	4	8	B
R1170D491B	E	4	9	B
R1170D501B	E	5	0	B

R1170S SERIES MARK SPECIFICATION

● HSOP-6J

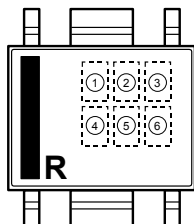

- ① : A (fixed)
- ②, ③ : Setting Voltage } (refer to Part Number vs. Product Code)
- ④ : Type (A,B)
- ⑤, ⑥ : Lot Number

● Part Number vs. Product Code

Part Number	Product Code			
	①	②	③	④
R1170S151A	A	1	5	A
R1170S161A	A	1	6	A
R1170S171A	A	1	7	A
R1170S181A	A	1	8	A
R1170S191A	A	1	9	A
R1170S201A	A	2	0	A
R1170S211A	A	2	1	A
R1170S221A	A	2	2	A
R1170S231A	A	2	3	A
R1170S241A	A	2	4	A
R1170S251A	A	2	5	A
R1170S261A	A	2	6	A
R1170S271A	A	2	7	A
R1170S281A	A	2	8	A
R1170S291A	A	2	9	A
R1170S301A	A	3	0	A
R1170S311A	A	3	1	A
R1170S321A	A	3	2	A

Part Number	Product Code			
	①	②	③	④
R1170S331A	A	3	3	A
R1170S341A	A	3	4	A
R1170S351A	A	3	5	A
R1170S361A	A	3	6	A
R1170S371A	A	3	7	A
R1170S381A	A	3	8	A
R1170S391A	A	3	9	A
R1170S401A	A	4	0	A
R1170S411A	A	4	1	A
R1170S421A	A	4	2	A
R1170S431A	A	4	3	A
R1170S441A	A	4	4	A
R1170S451A	A	4	5	A
R1170S461A	A	4	6	A
R1170S471A	A	4	7	A
R1170S481A	A	4	8	A
R1170S491A	A	4	9	A
R1170S501A	A	5	0	A

Part Number	Product Code			
	①	②	③	④
R1170S151B	A	1	5	B
R1170S161B	A	1	6	B
R1170S171B	A	1	7	B
R1170S181B	A	1	8	B
R1170S191B	A	1	9	B
R1170S201B	A	2	0	B
R1170S211B	A	2	1	B
R1170S221B	A	2	2	B
R1170S231B	A	2	3	B
R1170S241B	A	2	4	B
R1170S251B	A	2	5	B
R1170S261B	A	2	6	B
R1170S271B	A	2	7	B
R1170S281B	A	2	8	B
R1170S291B	A	2	9	B
R1170S301B	A	3	0	B
R1170S311B	A	3	1	B
R1170S321B	A	3	2	B

Part Number	Product Code			
	①	②	③	④
R1170S331B	A	3	3	B
R1170S341B	A	3	4	B
R1170S351B	A	3	5	B
R1170S361B	A	3	6	B
R1170S371B	A	3	7	B
R1170S381B	A	3	8	B
R1170S391B	A	3	9	B
R1170S401B	A	4	0	B
R1170S411B	A	4	1	B
R1170S421B	A	4	2	B
R1170S431B	A	4	3	B
R1170S441B	A	4	4	B
R1170S451B	A	4	5	B
R1170S461B	A	4	6	B
R1170S471B	A	4	7	B
R1170S481B	A	4	8	B
R1170S491B	A	4	9	B
R1170S501B	A	5	0	B