120mA LDO REGULATOR

NO.EA-074-0606

OUTLINE

The R1140Q Series are CMOS-based voltage regulator ICs with high output voltage accuracy, low supply current, low ON-resistance, and high ripple rejection. Each of these voltage regulator ICs consists of a voltage reference unit, an error amplifier, resistors for setting Output Voltage, a current limit circuit, and a chip enable circuit.

These ICs perform with low dropout voltage and a chip enable function. The line transient response and load transient response of the R1140Q Series are excellent, thus these ICs are very suitable for the power supply for hand-held communication equipment.

The output voltage of these ICs is internally fixed with high accuracy. Since the package for these ICs is SC-82AB (Super Mini-mold) package, high density mounting of the ICs on boards is possible.

FEATURES

- Ultra-Low Supply Current..... Typ. 75 μ A
- Standby Mode Typ. 0.1 μ A
- Low Dropout Voltage..... Typ. 0.15V ($I_{OUT}=100$ mA, Output Voltage=3.0V Type)
- High Ripple Rejection Typ. 75dB (f=1kHz)
- Low Temperature-Drift Coefficient of Output Voltage... Typ. ± 100 ppm/ $^{\circ}$ C
- Excellent Line Regulation Typ. 0.05%/V
- High Output Voltage Accuracy $\pm 2.0\%$
- Output Voltage Range..... 1.5V to 4.0V
- Excellent Dynamic Response
- Small Package SC-82AB (Super Mini-mold)
- Built-in Chip Enable Circuit (B/D : active high)
- Built-in Fold-back Protection Circuit..... Typ. 40mA (Current at short mode)

APPLICATION

- Power source for cellular phones such as GSM, CDMA and various kinds of PCS.
- Power source for electrical appliances such as cameras, VCRs and camcorders.
- Power source for battery-powered equipment.

BLOCK DIAGRAMS

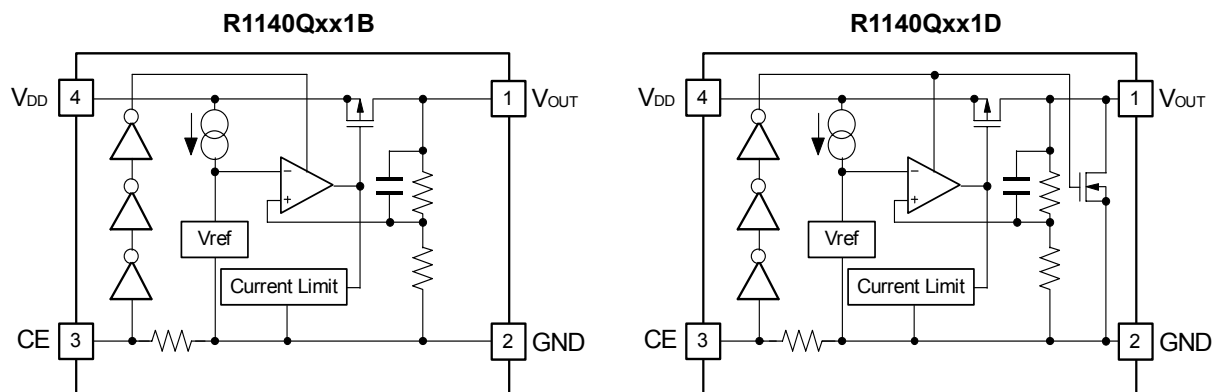

SELECTION GUIDE

The output voltage, mask option, and the taping type for the ICs can be selected at the user's request. The selection can be made by designating the part number as shown below;:

R1140Qxx1x-xx-x ← Part Number
 ↑ ↑ ↑ ↑ ↑
 a b c d e

Code	Contents
a	Designation of Package Type Q: SC-82AB (Super Mini-mold)
b	Setting Output Voltage (V_{OUT}): Stepwise setting with a step of 0.1V in the range of 1.5V to 4.0V is possible.
c	Designation of Mask Option : B: Without auto discharge function at OFF state. D: With auto discharge function at OFF state.
d	Designation of Taping Type : Ex. TR, TL (refer to Taping Specifications; TR type is the standard direction.)
e	Designation of composition of pin plating -F : Lead free plating

PIN CONFIGURATION

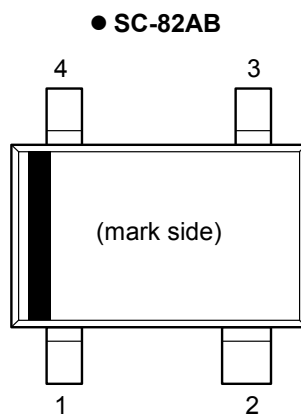

PIN DESCRIPTION

Pin No	Symbol	Pin Description
1	V_{OUT}	Output Pin
2	GND	Ground Pin
3	CE	Chip Enable Pin
4	V_{DD}	Input Pin

ABSOLUTE MAXIMUM RATINGS

Symbol	Item	Rating	Unit
V_{IN}	Input Voltage	6.5	V
V_{CE}	Input Voltage (CE Pin)	-0.3 to $V_{IN} + 0.3$	V
V_{OUT}	Output Voltage	-0.3 to $V_{IN} + 0.3$	V
I_{OUT}	Output Current	140	mA
P_D	Power Dissipation (SC-82AB)*	380	mW
T_{opt}	Operating Temperature Range	-40 to 85	°C
T_{stg}	Storage Temperature Range	-55 to 125	°C

*) For Power Dissipation, please refer to PACKAGE INFORMATION to be described.

ELECTRICAL CHARACTERISTICS

• R1140Qxx1B/D

T_{opt}=25°C

Symbol	Item	Conditions	Min.	Typ.	Max.	Unit
V _{OUT}	Output Voltage	V _{IN} =Set V _{OUT} +1.0V 1mA ≤ I _{OUT} ≤ 30mA	V _{OUT} × 0.98		V _{OUT} × 1.02	V
I _{OUT}	Output Current	V _{IN} -V _{OUT} =1.0V	120			mA
ΔV _{OUT} /ΔI _{OUT}	Load Regulation	V _{IN} =Set V _{OUT} +1.0V 1mA ≤ I _{OUT} ≤ 120mA		12	40	mV
V _{DIF}	Dropout Voltage	Refer to the ELECTRICAL CHARACTERISTICS by OUTPUT VOLTAGE				
I _{SS}	Supply Current	V _{IN} =Set V _{OUT} +1.0V		75	150	μA
I _{standby}	Supply Current (Standby)	V _{IN} =V _{CE} =Set V _{OUT} +1.0V		0.1	1.0	μA
ΔV _{OUT} /ΔV _{IN}	Line Regulation	Set V _{OUT} +0.5V ≤ V _{IN} ≤ 6.0V I _{OUT} =30mA (In case that V _{OUT} ≤ 1.6V, 2.2V ≤ V _{IN} ≤ 6.0V)		0.05	0.20	%/V
RR	Ripple Rejection	f=1kHz, Ripple 0.5Vp-p V _{IN} =Set V _{OUT} +1V, I _{OUT} =30mA (In case that V _{OUT} ≤ 1.7V, V _{IN} -V _{OUT} =1.2V)		75		dB
V _{IN}	Input Voltage		2.2		6.0	V
ΔV _{OUT} /ΔT _{opt}	Output Voltage Temperature Coefficient	I _{OUT} =30mA -40°C ≤ T _{opt} ≤ 85°C		±100		ppm/ °C
I _{LIM}	Short Current Limit	V _{OUT} =0V		40		mA
R _{PU}	\overline{CE} Pull up resistance		1.5	4.0	16.0	MΩ
V _{CEH}	\overline{CE} Input Voltage "H"		1.5		V _{IN}	V
V _{CEL}	\overline{CE} Input Voltage "L"		0.0		0.3	V
e _n	Output Noise	BW=10Hz to 100kHz		30		μVrms
R _{LOW}	Low Output Nch Tr. ON Resistance (of D version)	V _{CE} =0V		70		Ω

• ELECTRICAL CHARACTERISTICS by OUTPUT VOLTAGE

T_{opt} = 25°C

Output Voltage V _{OUT} (V)	Dropout Voltage V _{DIF} (V)		
	Condition	Typ.	Max.
1.5V ≤ V _{OUT} ≤ 1.6V	I _{OUT} =120mA	0.36	0.70
1.7V ≤ V _{OUT} ≤ 1.8V		0.30	0.50
1.9V ≤ V _{OUT} ≤ 2.0V		0.28	0.45
2.1V ≤ V _{OUT} ≤ 2.7V		0.24	0.40
2.8V ≤ V _{OUT} ≤ 4.0V		0.18	0.30

TECHNICAL NOTES

When using these ICs, consider the following points:

Phase Compensation

In these ICs, phase compensation is made for securing stable operation even if the load current is varied. For this purpose, be sure to use a $2.2\mu\text{F}$ or more capacitor C_{OUT} with good frequency characteristics and ESR (Equivalent Series Resistance).

(Note: When the additional ceramic capacitors are connected to the Output Pin with Output capacitor for phase compensation, the operation might be unstable. Because of this, test these ICs with as same external components as ones to be used on the PCB.)

PCB Layout

Make V_{DD} and GND line sufficient. When the impedance of these is high, it would be a cause of picking up the noise or unstable operation. Connect a capacitor with as much as $1.0\mu\text{F}$ capacitor between V_{DD} and GND pin as close as possible.

Set external components, especially output capacitor as close as possible to the ICs and make wiring shortest.

TYPICAL APPLICATION

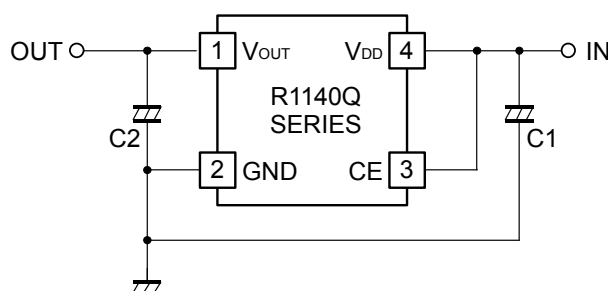

(External Components)
Output Capacitor; Tantalum Type

TEST CIRCUITS

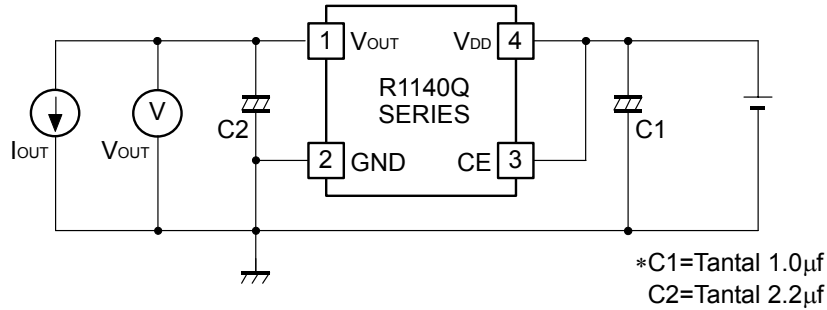

Fig.1 Standard test Circuit

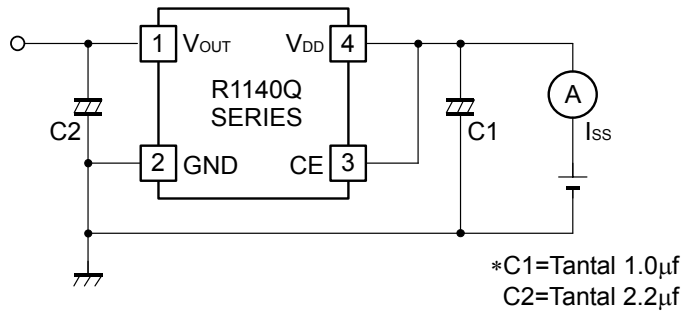

Fig.2 Supply Current Test Circuit

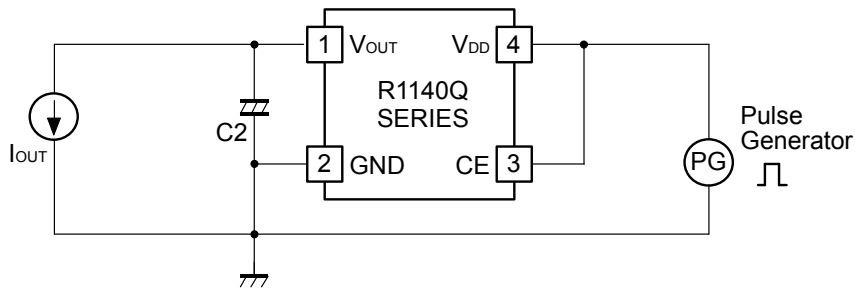

Fig.3 Ripple Rejection, Line Transient Response Test Circuit

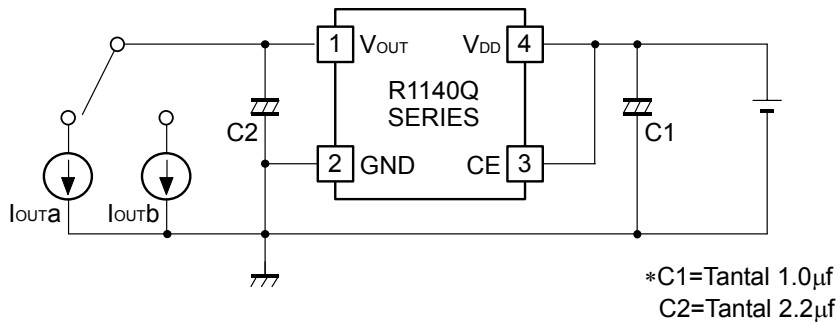
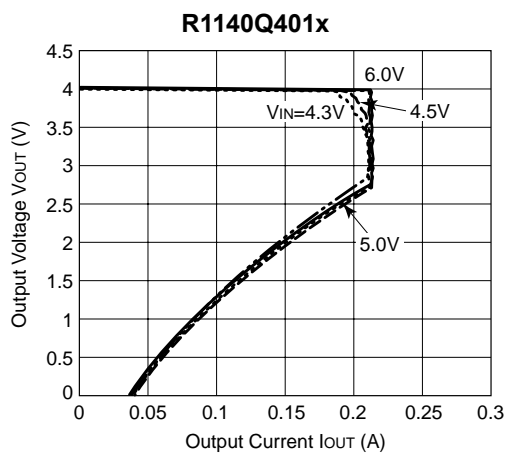
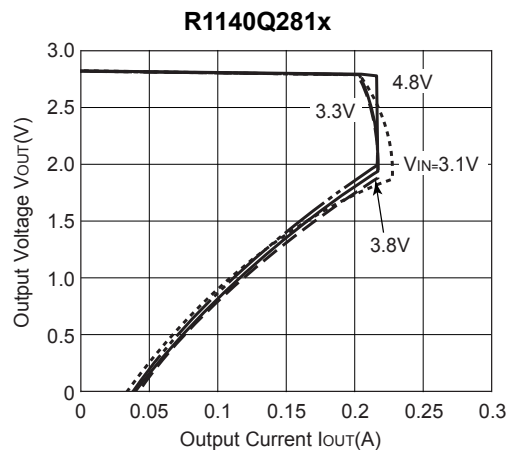
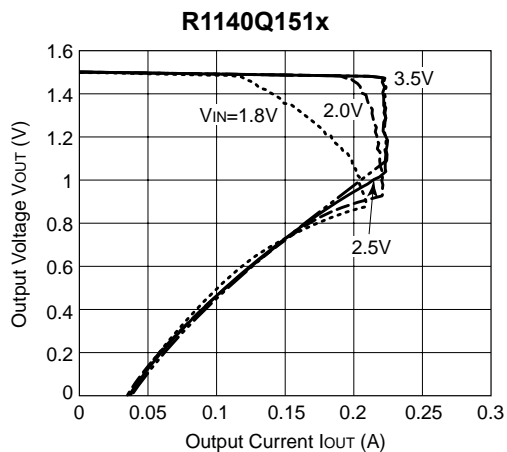

Fig.4 Load Transient Response Test Circuit

TYPICAL CHARACTERISTICS

1) Output Voltage vs. Output Current



2) Output Voltage vs. Input Voltage

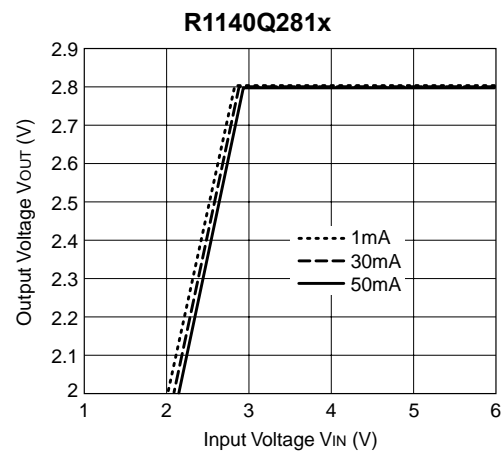
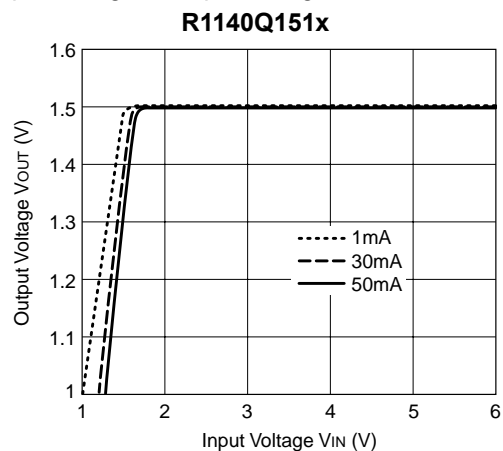

R1140Q

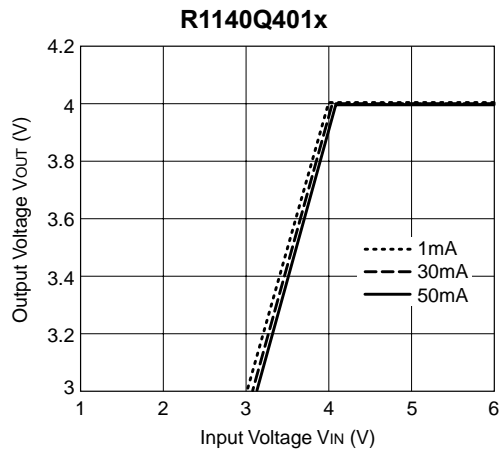

3) Dropout Voltage vs. Output Current

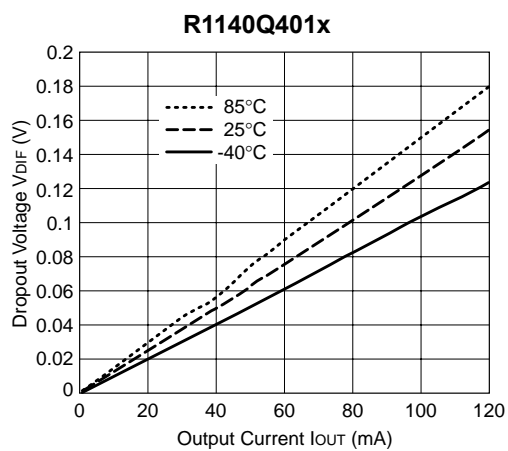
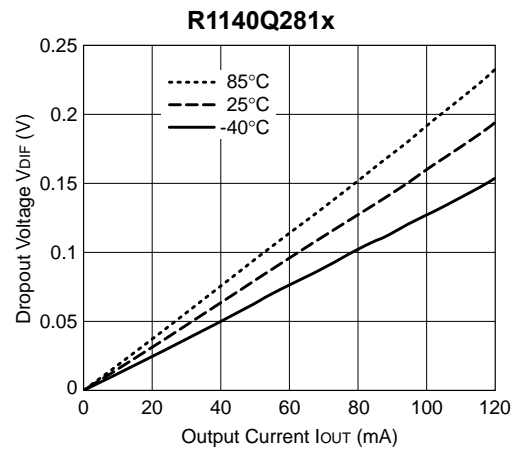
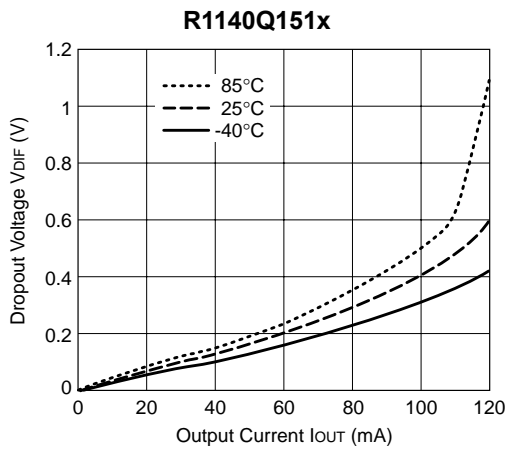

4) Output Voltage vs. Temperature

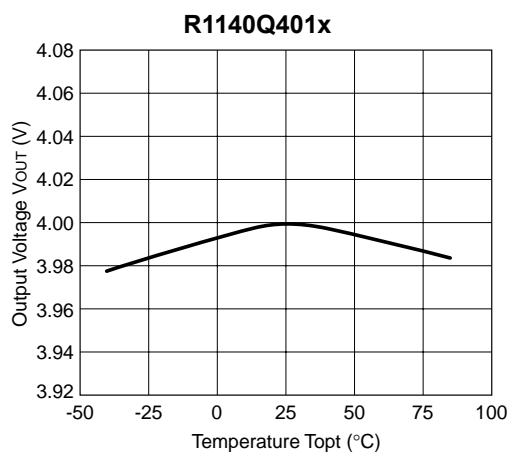
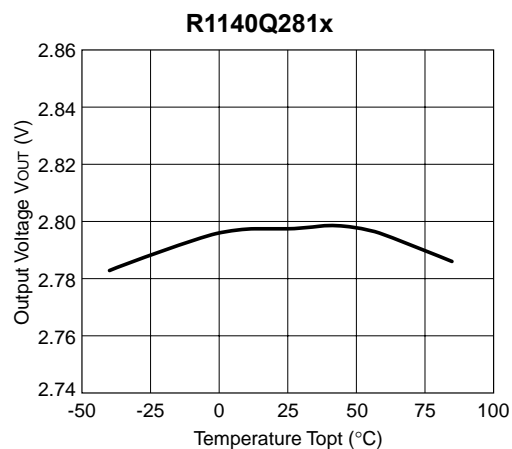
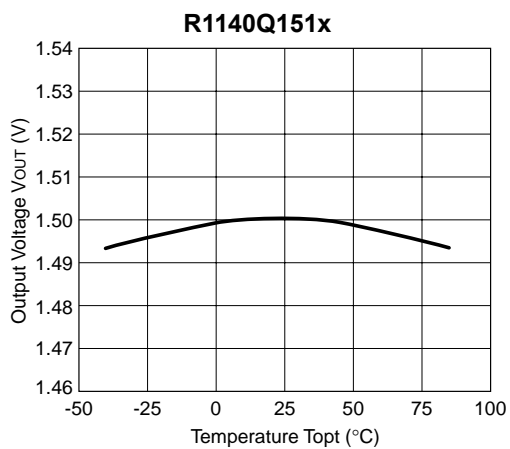

5) Supply Current vs. Input Voltage

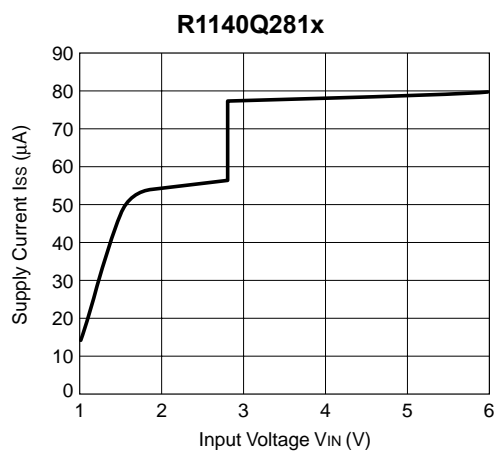
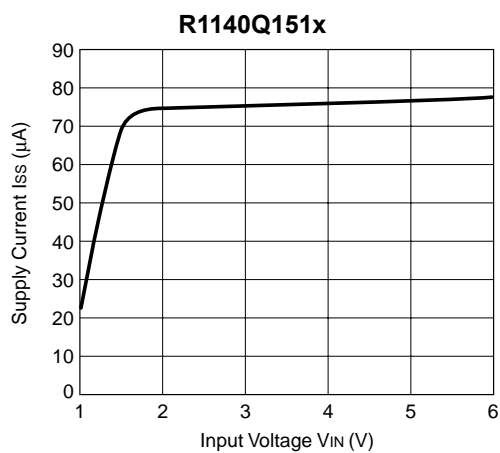

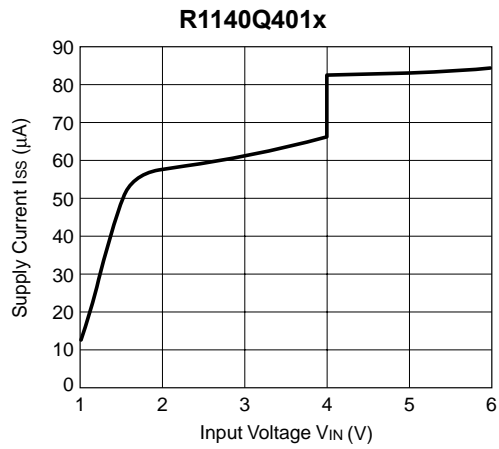

6) Supply Current vs. Temperature

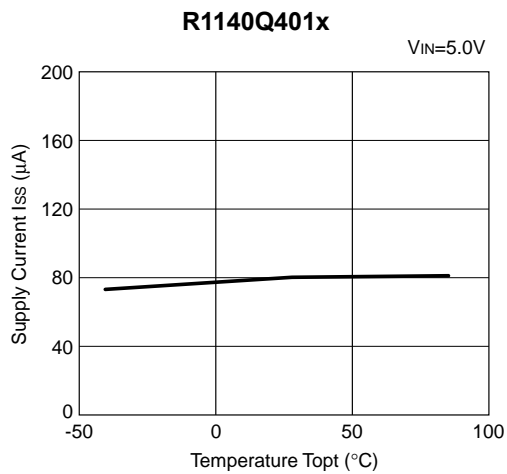
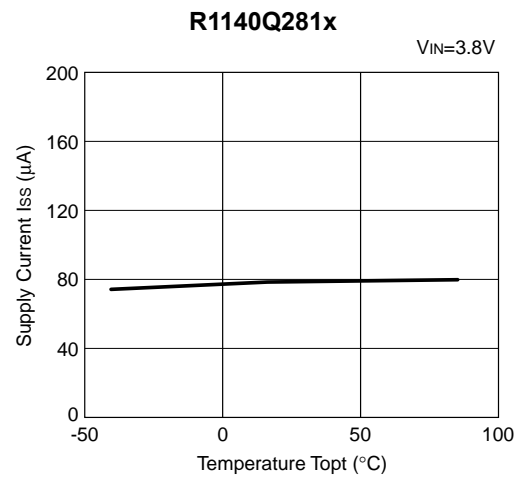
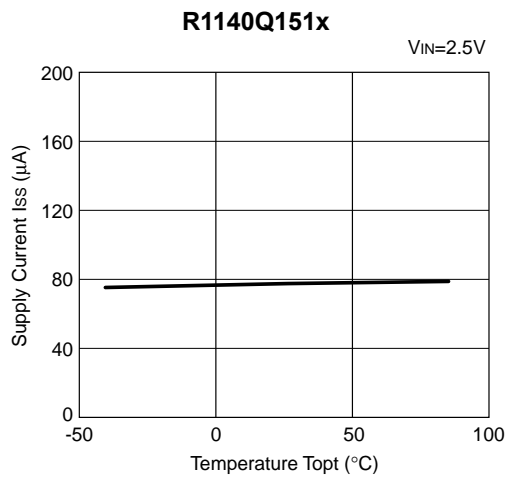

7) Dropout Voltage vs. Set Output Voltage

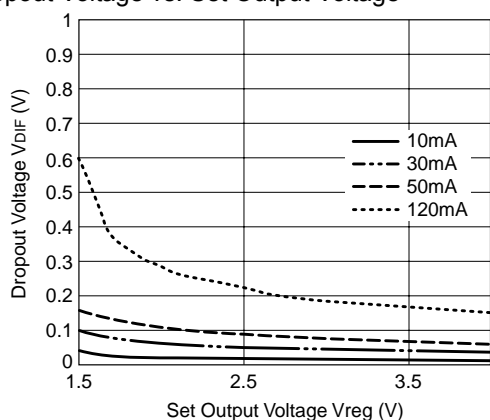

8) Ripple Rejection vs. Frequency

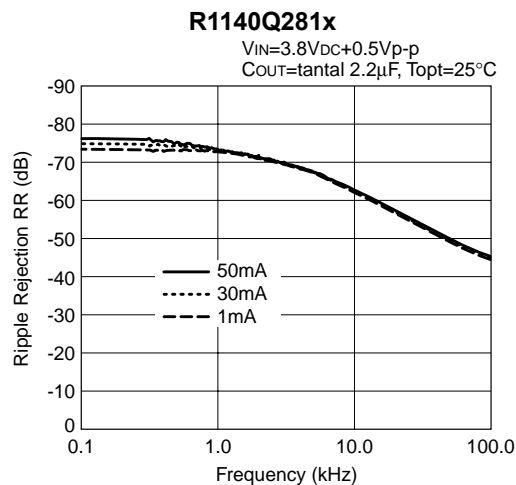
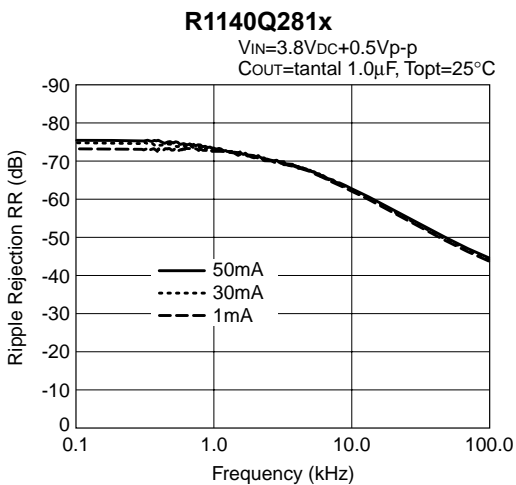
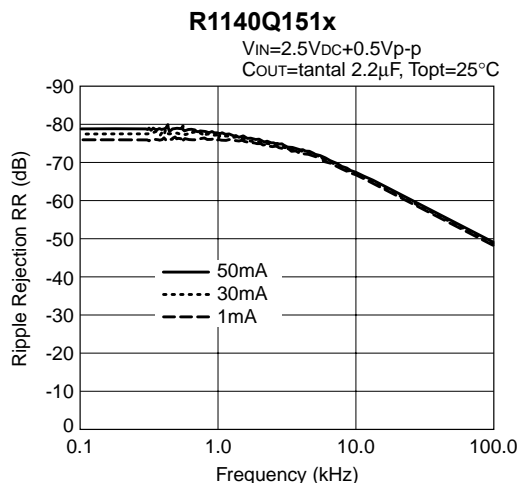
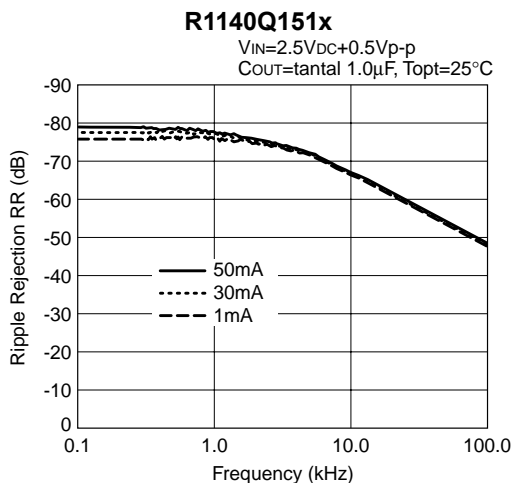

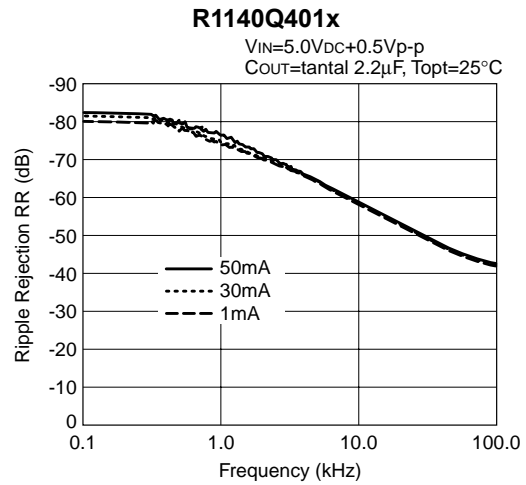
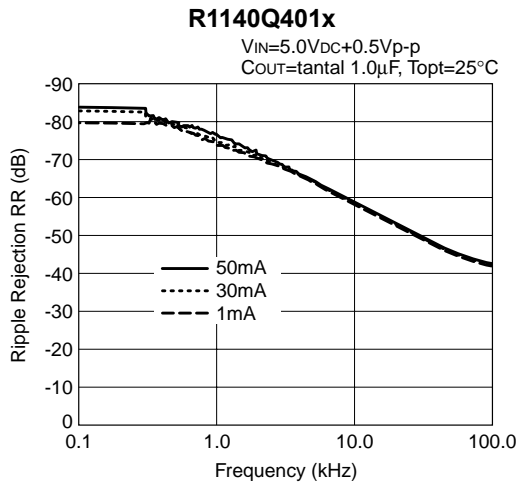

9) Ripple Rejection vs. Input Bias

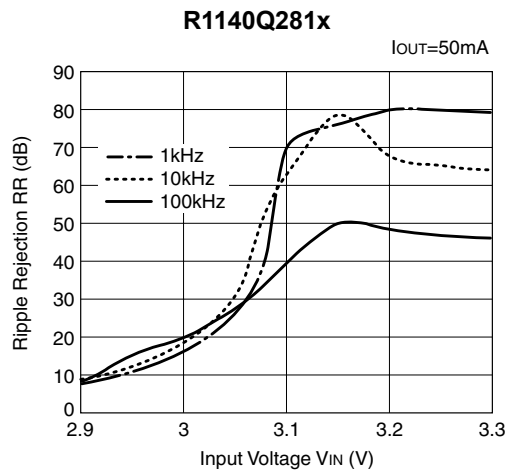
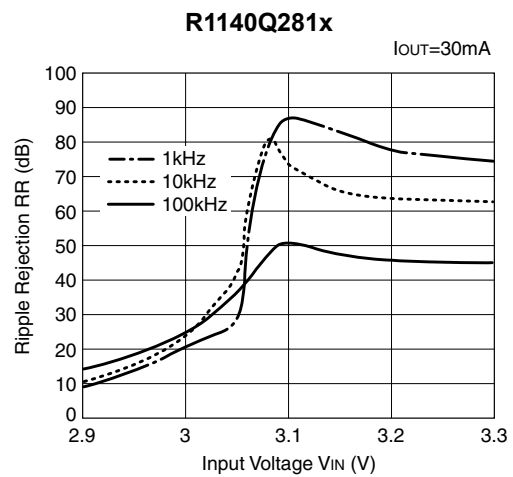
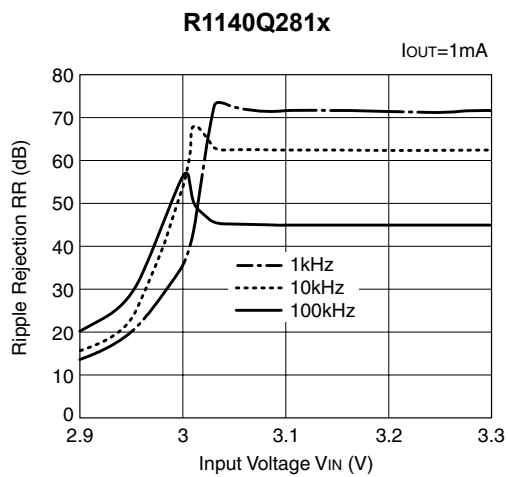

10) Input Transient Response

R1140Q281x

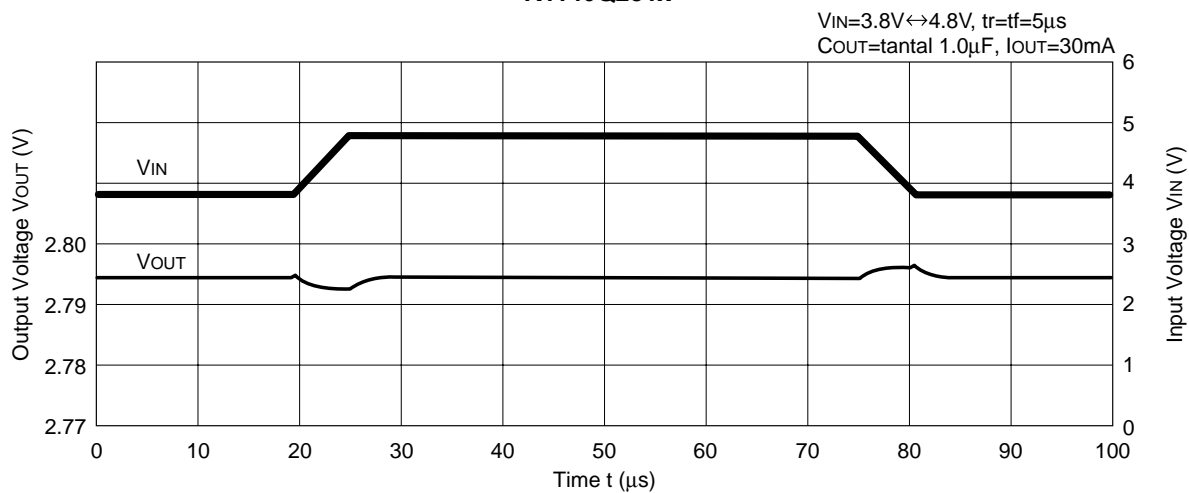

R1140Q281x

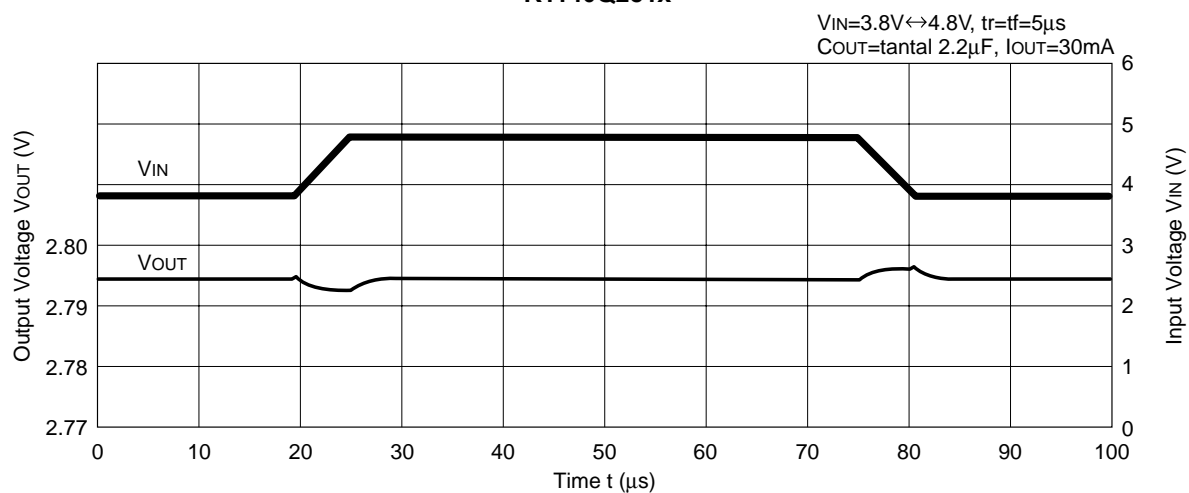

R1140Q281x

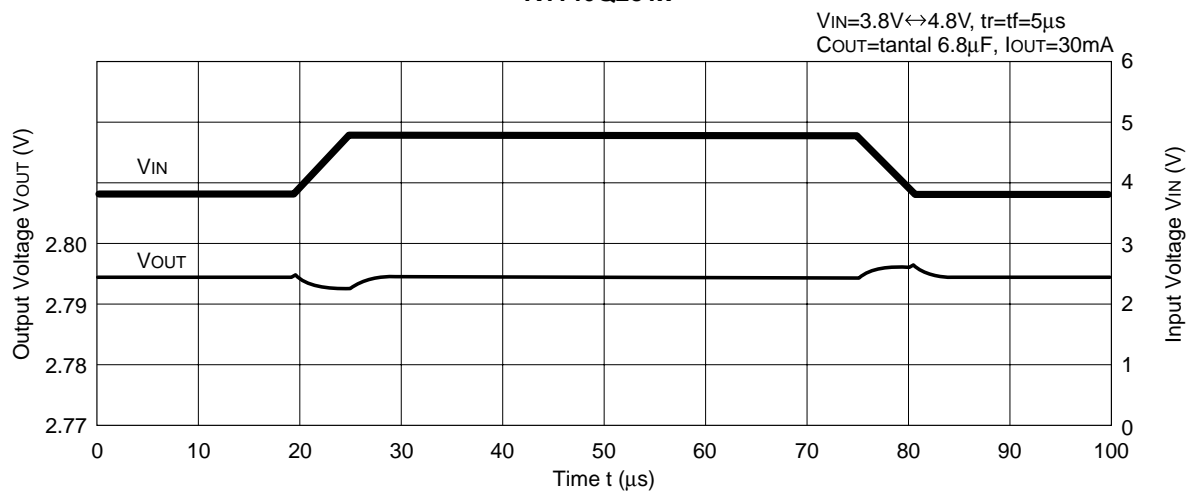

11) Input Transient Response

R1140Q281x

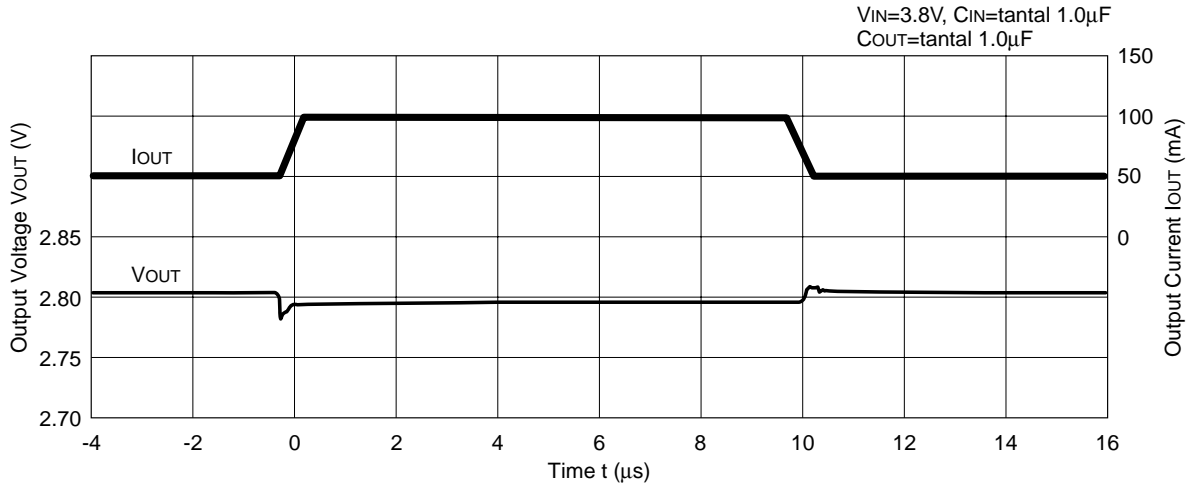

R1140Q281x

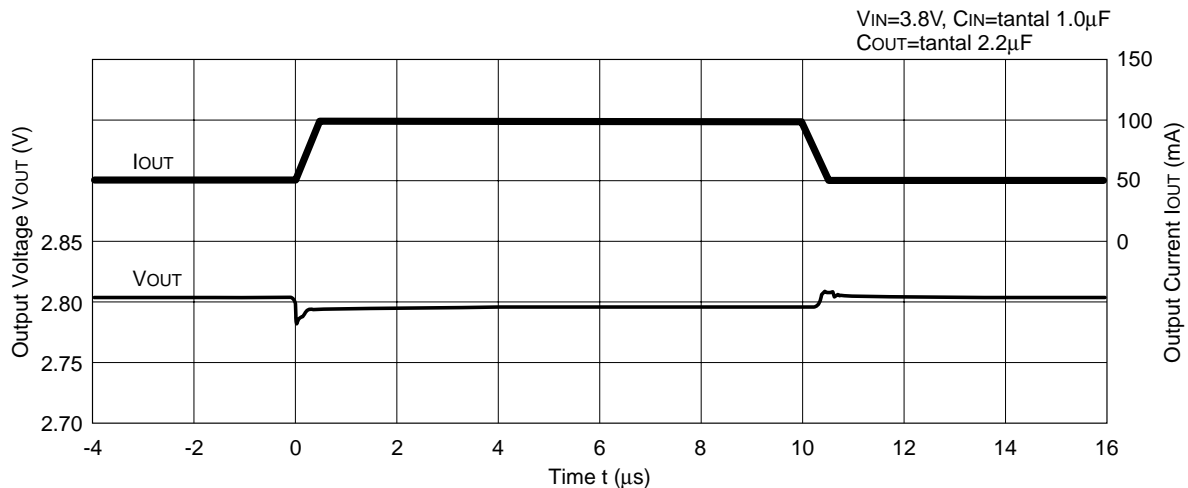

R1140Q281x

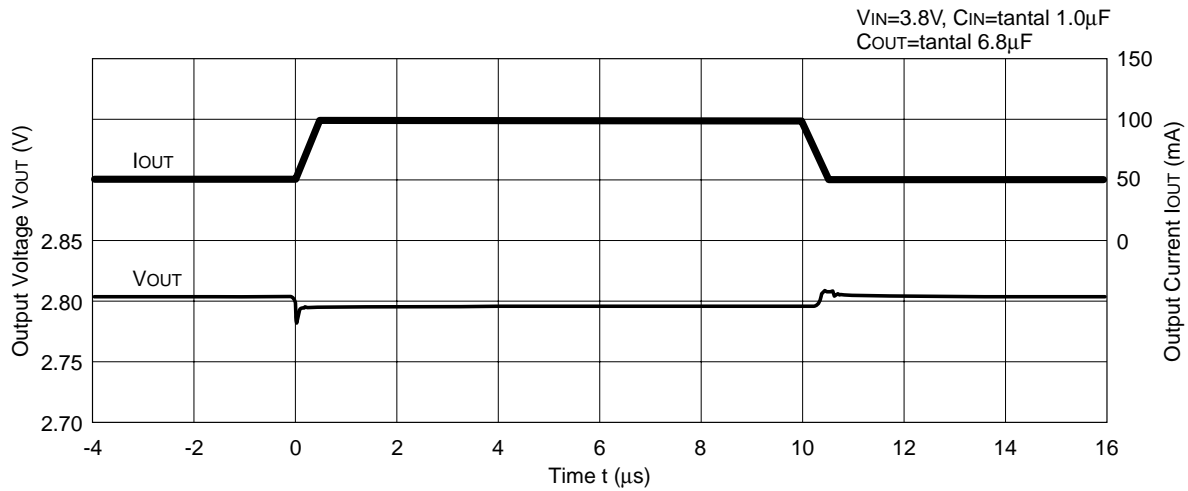

ESR vs. Output Current

When using these ICs, consider the following points:

In these ICs, phase compensation is made for securing stable operation even if the load current is varied. For this purpose, be sure to use a capacitor C_{OUT} with good frequency characteristics and ESR (Equivalent Series Resistance) of which is in the range described as follows:

The relations between I_{OUT} (Output Current) and ESR of Output Capacitor are shown below. The conditions when the white noise level is under $40\mu\text{V}$ (Avg.) are marked as the hatched area in the graph.

<Test conditions>

- (1) $V_{IN}=3.8\text{V}$
- (2) Frequency band: 10Hz to 2MHz
- (3) Temperature: 25°C

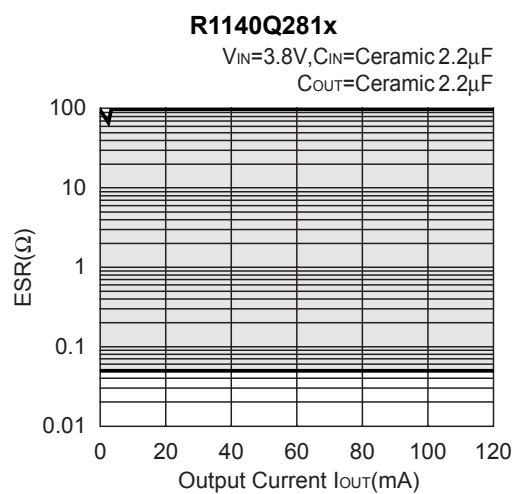
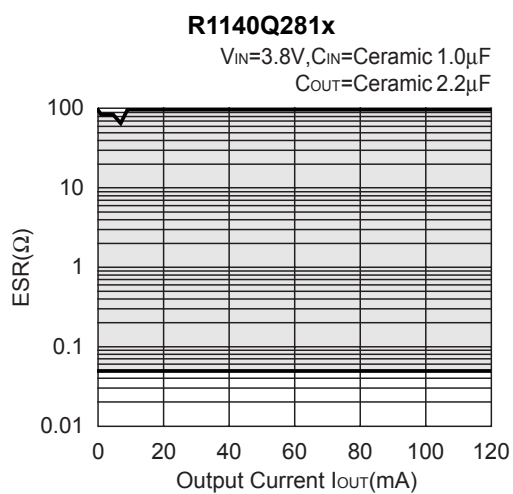

• SC-82AB

Unit: mm

PACKAGE DIMENSIONS

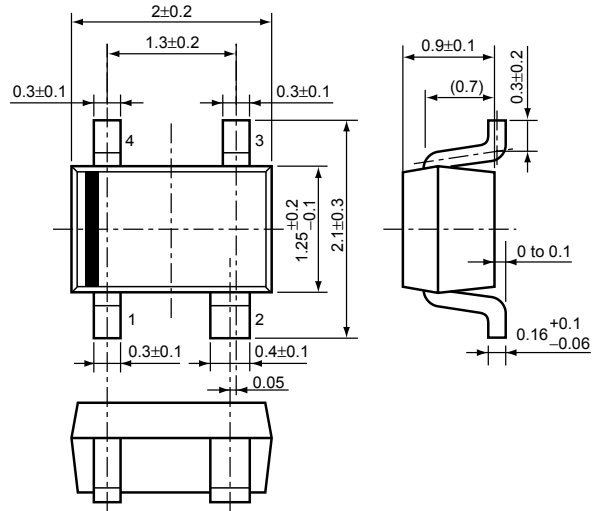

TAPING SPECIFICATION

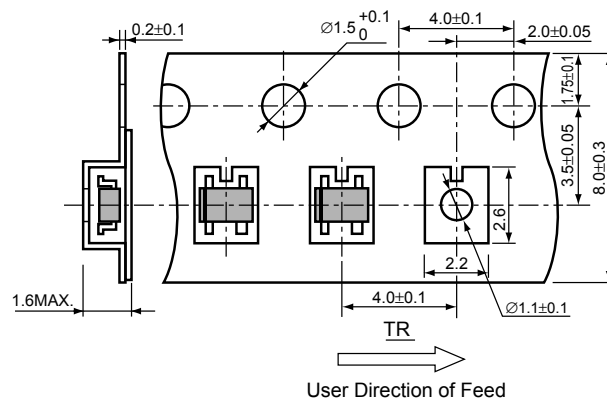

TAPING REEL DIMENSIONS

(1reel=3000pcs)

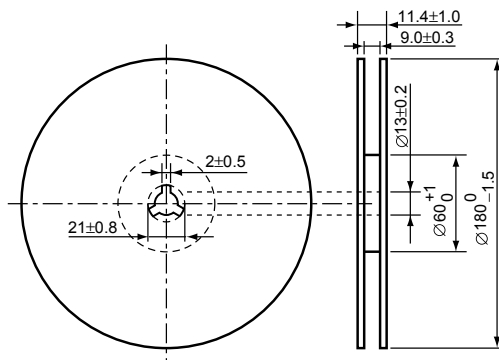

POWER DISSIPATION (SC-82AB)

This specification is at mounted on board. Power Dissipation (P_D) depends on conditions of mounting on board. This specification is based on the measurement at the condition below:

Measurement Conditions

	Standard Land Pattern
Environment	Mounting on Board (Wind velocity=0m/s)
Board Material	Glass cloth epoxy plactic (Double sided)
Board Dimensions	40mm × 40mm × 1.6mm
Copper Ratio	Top side : Approx. 50% , Back side : Approx. 50%
Through-hole	φ0.5mm × 44pcs

Measurement Result

($T_{opt}=25^{\circ}C, T_{jmax}=125^{\circ}C$)

	Standard Land Pattern	Free Air
Power Dissipation	380mW	150mW
Thermal Resistance	$\theta_{ja}=(125-25^{\circ}C)/0.38W=263^{\circ}C/W$	667 $^{\circ}C/W$

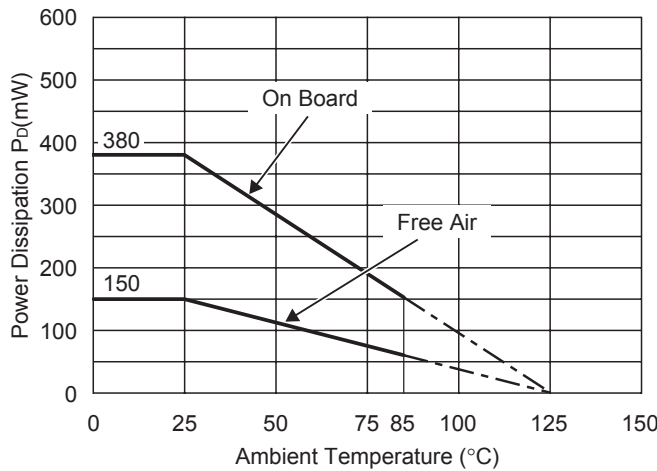

Power Dissipation

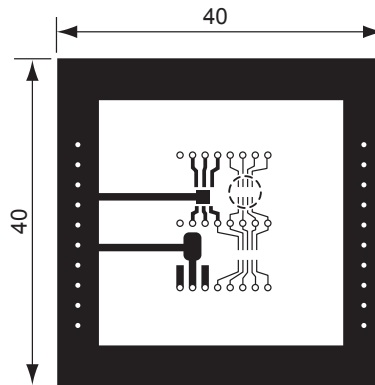

Measurement Board Pattern

○ IC Mount Area (Unit : mm)

RECOMMENDED LAND PATTERN

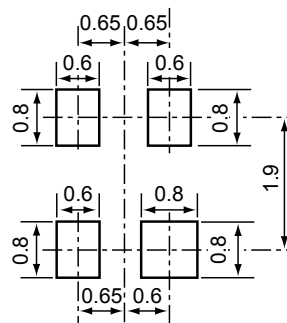

(Unit: mm)

R1140Q SERIES MARK SPECIFICATION

● **SC-82AB**

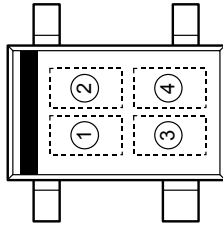

①, ② : Product Code (refer to Part Number vs. Product Code)
 ③, ④ : Lot Number

● **Part Number vs. Product Code**

Part Number	Product Code		Part Number	Product Code		Part Number	Product Code		Part Number	Product Code	
	①	②		①	②		①	②		①	②
R1140Q151B	A	5	R1140Q281B	B	8	R1140Q151D	E	5	R1140Q281D	F	8
R1140Q161B	A	6	R1140Q291B	B	9	R1140Q161D	E	6	R1140Q291D	F	9
R1140Q171B	A	7	R1140Q301B	C	0	R1140Q171D	E	7	R1140Q301D	G	0
R1140Q181B	A	8	R1140Q311B	C	1	R1140Q181D	E	8	R1140Q311D	G	1
R1140Q191B	A	9	R1140Q321B	C	2	R1140Q191D	E	9	R1140Q321D	G	2
R1140Q201B	B	0	R1140Q331B	C	3	R1140Q201D	F	0	R1140Q331D	G	3
R1140Q211B	B	1	R1140Q341B	C	4	R1140Q211D	F	1	R1140Q341D	G	4
R1140Q221B	B	2	R1140Q351B	C	5	R1140Q221D	F	2	R1140Q351D	G	5
R1140Q231B	B	3	R1140Q361B	C	6	R1140Q231D	F	3	R1140Q361D	G	6
R1140Q241B	B	4	R1140Q371B	C	7	R1140Q241D	F	4	R1140Q371D	G	7
R1140Q251B	B	5	R1140Q381B	C	8	R1140Q251D	F	5	R1140Q381D	G	8
R1140Q261B	B	6	R1140Q391B	C	9	R1140Q261D	F	6	R1140Q391D	G	9
R1140Q271B	B	7	R1140Q401B	D	0	R1140Q271D	F	7	R1140Q401D	H	0