

Switching Diode

FEATURE

- Small plastic SMD package.
- Continuous reverse voltage: max. 75 V.
- High-speed switching in hybrid thick and thin-film circuits.
- We declare that the material of product compliance with RoHS requirements.

DEVICE MARKING AND ORDERING INFORMATION

Device	Marking	Shipping
LBAS16HT1G	A6	3000/Tape&Reel
LBAS16HT3G	A6	10000/Tape&Reel

LBAS16HT1G

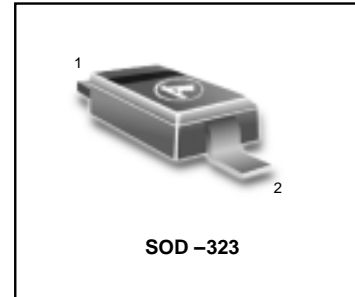

MAXIMUM RATINGS

Rating	Symbol	Value	Unit
Continuous Reverse Voltage	V_R	75	Vdc
Peak Forward Current	I_F	200	mAdc
Peak Forward Surge Current	$I_{FM}(\text{surge})$	500	mAdc

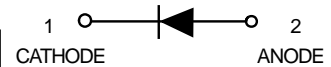

THERMAL CHARACTERISTICS

Characteristic	Symbol	Max	Unit
Total Device Dissipation FR-5 Board,* $T_A = 25^\circ\text{C}$	P_D	200	mW
Derate above 25°C		1.57	mW/ $^\circ\text{C}$
Thermal Resistance Junction to Ambient	$R_{\theta JA}$	635	$^\circ\text{C/W}$
Junction and Storage Temperature	T_J, T_{stg}	-55to+150	$^\circ\text{C}$

**FR-4 Minimum Pad

ELECTRICAL CHARACTERISTICS ($T_A = 25^\circ\text{C}$ unless otherwise noted)

Characteristic	Symbol	Min	Max	Unit
----------------	--------	-----	-----	------

OFF CHARACTERISTICS

Reverse Voltage Leakage Current ($V_R = 75 \text{ Vdc}$) ($V_R = 75 \text{ Vdc}, T_J = 150^\circ\text{C}$) ($V_R = 25 \text{ Vdc}, T_J = 150^\circ\text{C}$)	I_R	—	1.0 50 30	μAdc
Reverse Breakdown Voltage ($I_{BR} = 100 \mu\text{Adc}$)	$V_{(BR)}$	75	—	Vdc
Forward Voltage ($I_F = 1.0 \text{ mAdc}$) ($I_F = 10 \text{ mAdc}$) ($I_F = 50 \text{ mAdc}$) ($I_F = 150 \text{ mAdc}$)	V_F	—	715 855 1000 1250	mV
Diode Capacitance ($V_R = 0, f = 1.0 \text{ MHz}$)	C_D	—	2.0	pF
Forward Recovery Voltage ($I_F = 10 \text{ mAdc}, t_r = 20 \text{ ns}$)	V_{FR}	—	1.75	Vdc
Reverse Recovery Time ($I_F = I_R = 10 \text{ mAdc}, R_L = 50 \Omega$)	t_{rr}	—	6.0	ns
Stored Charge ($I_F = 10 \text{ mAdc}$ to $V_R = 5.0 \text{ Vdc}, R_L = 500 \Omega$)	Q_s	—	45	pC

LBAS16HT1G

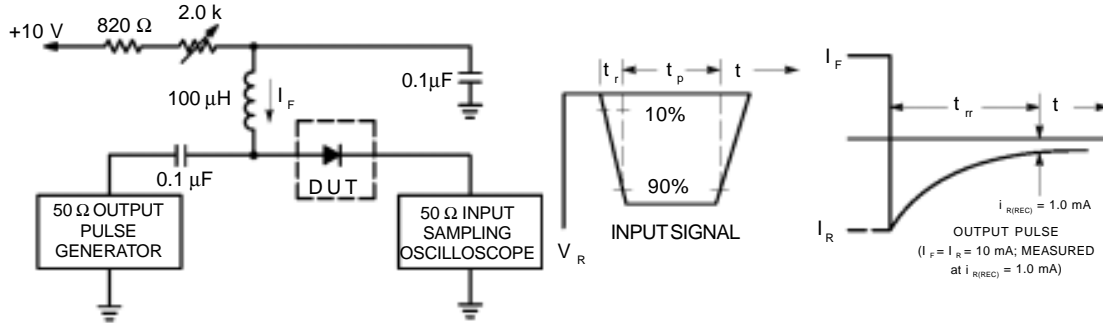

- Notes: 1. A 2.0 kΩ variable resistor adjusted for a Forward Current (I_F) of 10mA.
 2. Input pulse is adjusted so $I_{R(peak)}$ is equal to 10mA.
 3. $t_p \gg t_{rr}$

Figure 1. Recovery Time Equivalent Test Circuit

TYPICAL CHARACTERISTICS

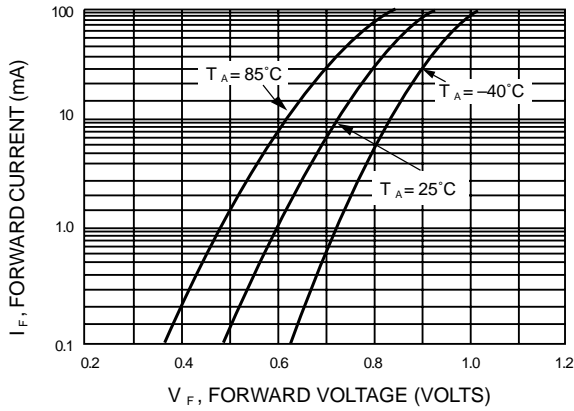

Figure 2. Forward Voltage

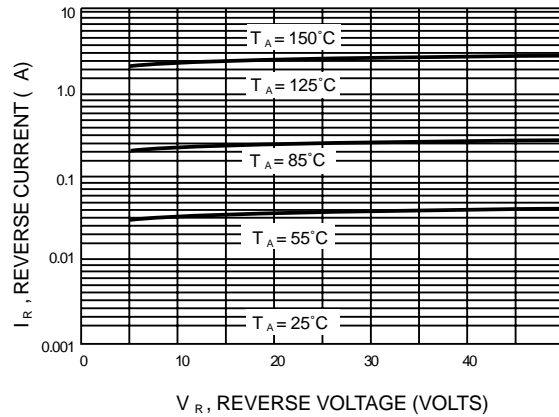

Figure 3. Leakage Current

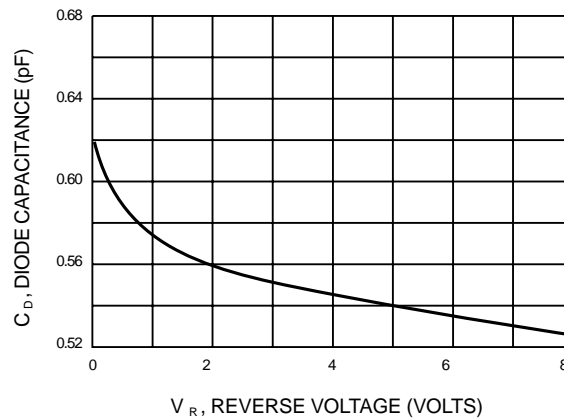
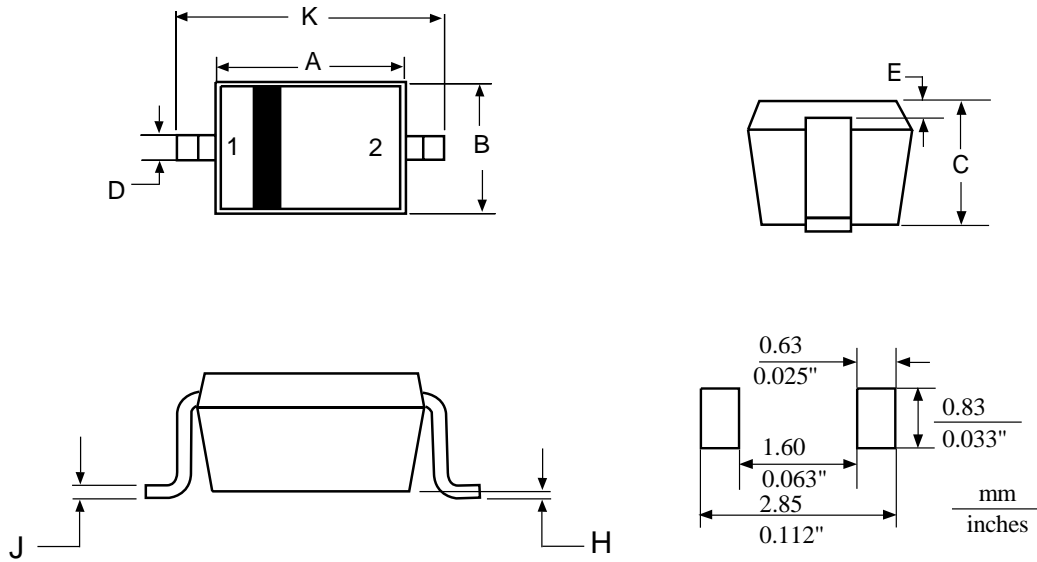

Figure 4. Capacitance

LBAS16HT1G

SOD-323



NOTES:

1. DIMENSIONING AND TOLERANCING PER ANSI Y14.5M, 1982.
2. CONTROLLING DIMENSION: MILLIMETERS

DIM	MILLIMETERS		INCHES	
	MIN	MAX	MIN	MAX
A	1.60	1.80	0.063	0.071
B	1.15	1.35	0.045	0.053
C	0.80	1.00	0.031	0.039
D	0.25	0.40	0.010	0.016
E	0.15 REF		0.006 REF	
H	0.00	0.10	0.000	0.004
J	0.089	0.177	0.0035	0.0070
K	2.30	2.70	0.091	0.106

PIN:1:CATHODE
2:ANODE