

DATA SHEET

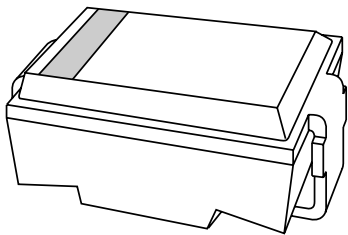

BZG03 series Voltage regulator diodes

Product specification
Supersedes data of 1996 Jun 07

2002 Jul 04

Voltage regulator diodes

BZG03 series

FEATURES

- Glass passivated
- High maximum operating temperature
- Low leakage current
- Excellent stability
- UL 94V-O classified plastic package
- Zener working voltage range: 10 to 270 V for 35 types
- Supplied in 12 mm embossed tape.

DESCRIPTION

DO-214AC surface mountable package with glass passivated chip.

The well-defined void-free case is of a transfer-moulded thermo-setting plastic.

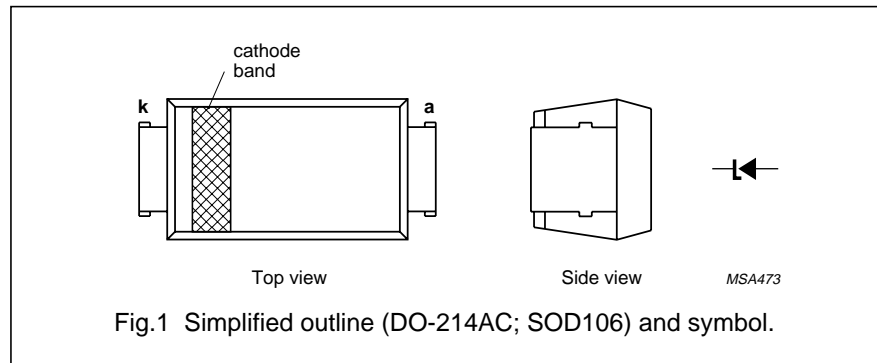

LIMITING VALUES

In accordance with the Absolute Maximum Rating System (IEC 60134).

SYMBOL	PARAMETER	CONDITIONS	MIN.	MAX.	UNIT
P _{tot}	total power dissipation	T _{tp} = 100 °C; see Fig.2	–	3.00	W
P _{tot}	total power dissipation	T _{amb} = 50 °C; see Fig.2; device mounted on an Al ₂ O ₃ PCB (see Fig.5)	–	1.25	W
P _{ZSM}	non-repetitive peak reverse power dissipation	t _p = 100 μs; square pulse; T _j = 25 °C prior to surge; see Fig.3	–	600	W
T _{stg}	storage temperature		–65	+175	°C
T _j	junction temperature		–65	+175	°C

Voltage regulator diodes

BZG03 series

ELECTRICAL CHARACTERISTICS

Total series

$T_j = 25\text{ }^\circ\text{C}$ unless otherwise specified.

SYMBOL	PARAMETER	CONDITIONS	MAX.	UNIT
V_F	forward voltage	$I_F = 0.5\text{ A}$; see Fig.4	1.2	V

Per type

$T_j = 25\text{ }^\circ\text{C}$ unless otherwise specified.

TYPE No. SUFFIX (1)	WORKING VOLTAGE			DIFFERENTIAL RESISTANCE		TEMPERATURE COEFFICIENT		TEST CURRENT I_Z (mA)	REVERSE CURRENT at REVERSE VOLTAGE	
	V_Z (V) at I_Z			r_{dif} (Ω) at I_Z		S_Z (%/K) at I_Z			I_R (μA)	V_R (V)
	MIN.	NOM.	MAX.	TYP.	MAX.	MIN.	MAX.	MAX.		
C10	9.4	10	10.6	2	4	0.05	0.09	50	7	7.5
C11	10.4	11	11.6	4	7	0.05	0.10	50	4	8.2
C12	11.4	12	12.7	4	7	0.05	0.10	50	3	9.1
C13	12.4	13	14.1	5	10	0.05	0.10	50	2	10
C15	13.8	15	15.6	5	10	0.05	0.10	50	1	11
C16	15.3	16	17.1	6	15	0.06	0.11	25	1	12
C18	16.8	18	19.1	6	15	0.06	0.11	25	1	13
C20	18.8	20	21.2	6	15	0.06	0.11	25	1	15
C22	20.8	22	23.3	6	15	0.06	0.11	25	1	16
C24	22.8	24	25.6	7	15	0.06	0.11	25	1	18
C27	25.1	27	28.9	7	15	0.06	0.11	25	1	20
C30	28	30	32	8	15	0.06	0.11	25	1	22
C33	31	33	35	8	15	0.06	0.11	25	1	24
C36	34	36	38	21	40	0.06	0.11	10	1	27
C39	37	39	41	21	40	0.06	0.11	10	1	30
C43	40	43	46	24	45	0.07	0.12	10	1	33
C47	44	47	50	24	45	0.07	0.12	10	1	36
C51	48	51	54	25	60	0.07	0.12	10	1	39
C56	52	56	60	25	60	0.07	0.12	10	1	43
C62	58	62	66	25	80	0.08	0.13	10	1	47
C68	64	68	72	25	80	0.08	0.13	10	1	51
C75	70	75	79	30	100	0.08	0.13	10	1	56
C82	77	82	87	30	100	0.08	0.13	10	1	62
C91	85	91	96	60	200	0.09	0.13	5	1	68
C100	94	100	106	60	200	0.09	0.13	5	1	75
C110	104	110	116	80	250	0.09	0.13	5	1	82
C120	114	120	127	80	250	0.09	0.13	5	1	91
C130	124	130	141	110	300	0.09	0.13	5	1	100
C150	138	150	156	130	300	0.09	0.13	5	1	110

Voltage regulator diodes

BZG03 series

TYPE No. SUFFIX (1)	WORKING VOLTAGE			DIFFERENTIAL RESISTANCE		TEMPERATURE COEFFICIENT		TEST CURRENT	REVERSE CURRENT at REVERSE VOLTAGE	
	V _Z (V) at I _Z			r _{diff} (Ω) at I _Z		S _Z (%/K) at I _Z		I _Z (mA)	I _R (μA)	V _R (V)
	MIN.	NOM.	MAX.	TYP.	MAX.	MIN.	MAX.		MAX.	
C160	153	160	171	150	350	0.09	0.13	5	1	120
C180	168	180	191	180	400	0.09	0.13	5	1	130
C200	188	200	212	200	500	0.09	0.13	5	1	150
C220	208	220	233	350	750	0.09	0.13	2	1	160
C240	228	240	256	400	850	0.09	0.13	2	1	180
C270	251	270	289	450	1000	0.09	0.13	2	1	200

Note

- To complete the type number the suffix is added to the basic type number, e.g. BZG03-C130.

THERMAL CHARACTERISTICS

SYMBOL	PARAMETER	CONDITIONS	VALUE	UNIT
R _{th j-tp}	thermal resistance from junction to tie-point		25	K/W
R _{th j-a}	thermal resistance from junction to ambient	note 1	100	K/W
		note 2	150	K/W

Notes

- Device mounted on an Al₂O₃ printed-circuit board, 0.7 mm thick; thickness of Cu-layer ≥35 μm, see Fig.5.
- Device mounted on an epoxy-glass printed-circuit board, 1.5 mm thick; thickness of Cu-layer ≥40 μm, see Fig.5. For more information please refer to the "General Part of associated Handbook".

Voltage regulator diodes

BZG03 series

GRAPHICAL DATA

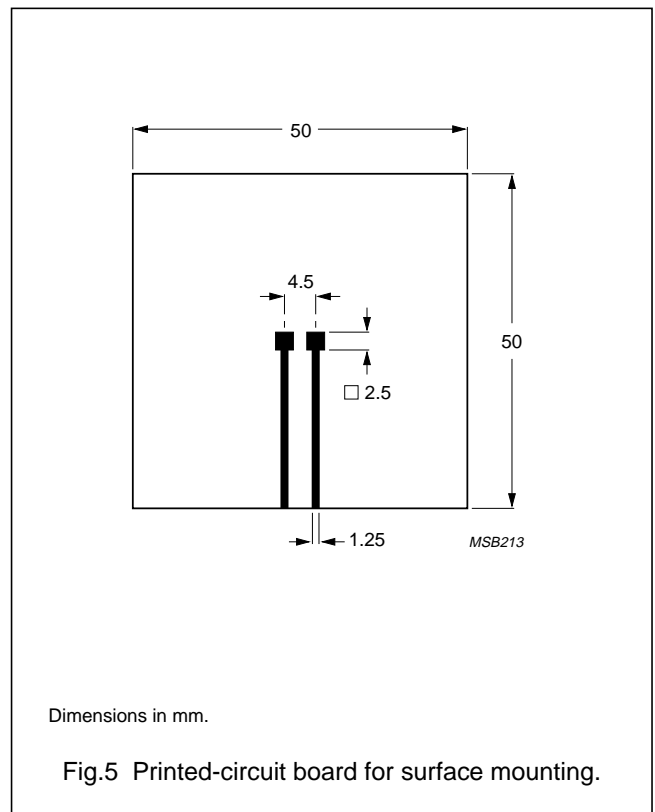
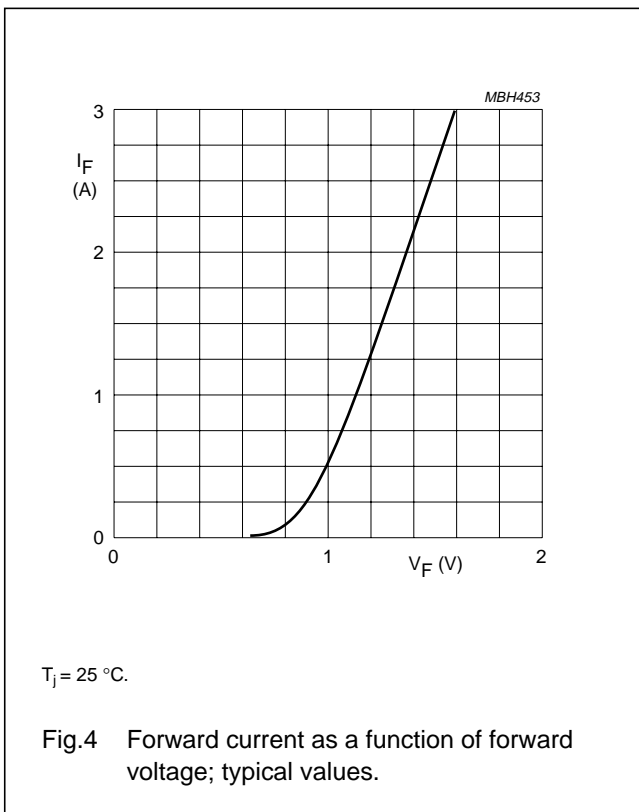
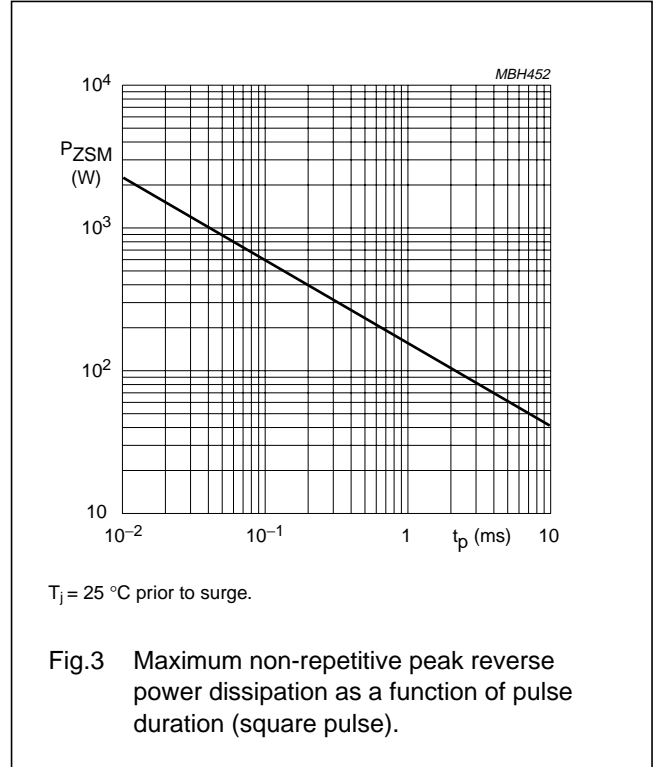
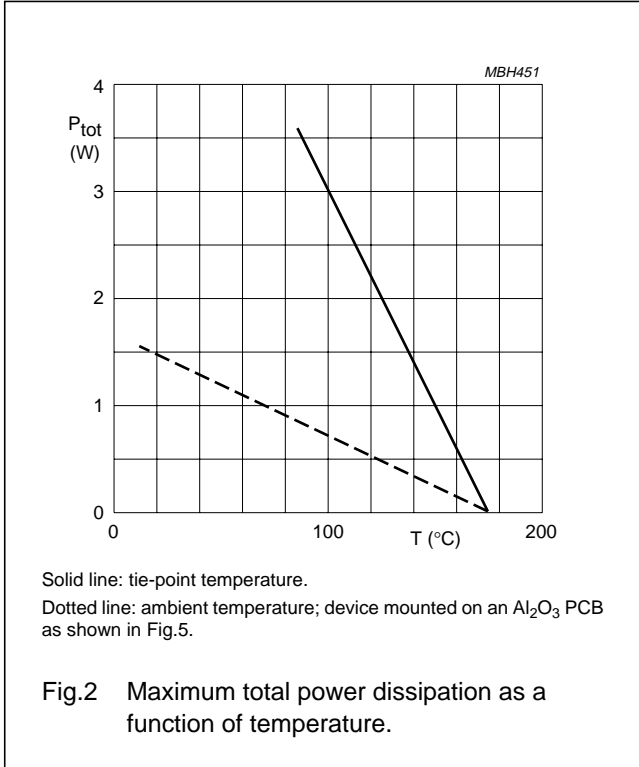

Voltage regulator diodes

BZG03 series

PACKAGE OUTLINE

Transfer-moulded thermo-setting plastic small rectangular surface mounted package;
2 connectors

SOD106

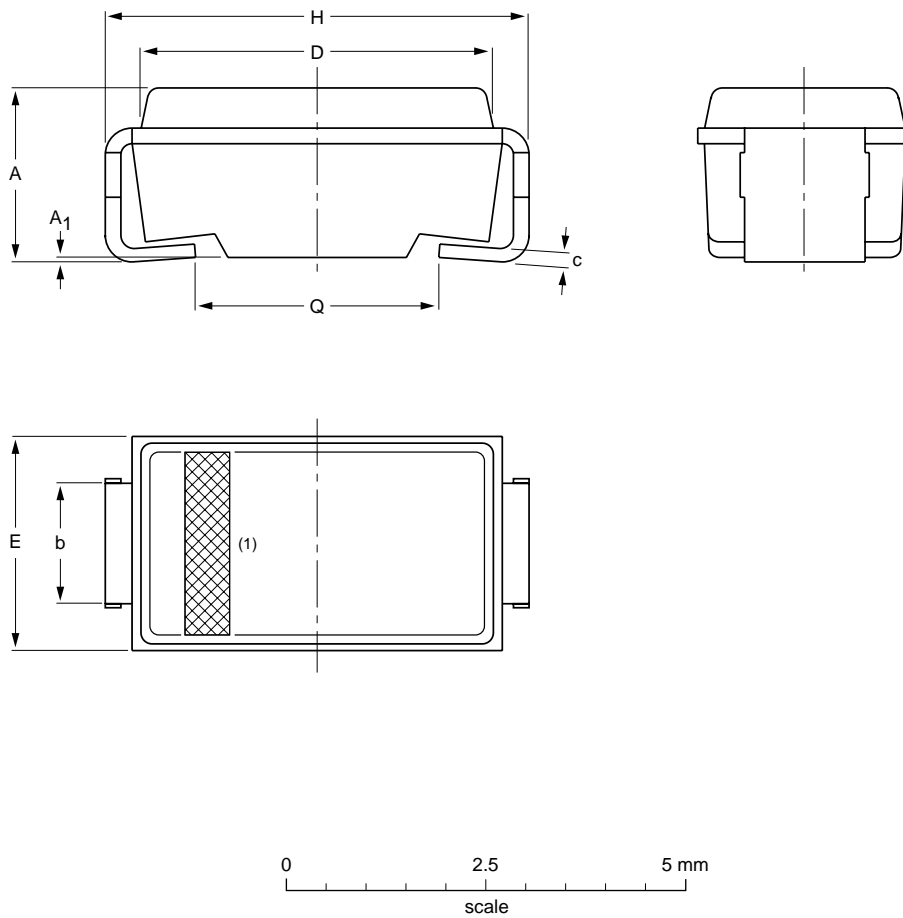

DIMENSIONS (mm are the original dimensions)

UNIT	A	A ₁	b	c	D	E	H	Q
mm	2.3 2.0	0.05	1.6 1.4	0.2	4.5 4.3	2.8 2.4	5.5 5.1	3.3 2.7

Note

1. The marking band indicates the cathode.

OUTLINE VERSION	REFERENCES			EUROPEAN PROJECTION	ISSUE DATE
	IEC	JEDEC	EIAJ		
SOD106		DO-214AC			97-06-09

Voltage regulator diodes

BZG03 series

DATA SHEET STATUS

DATA SHEET STATUS ⁽¹⁾	PRODUCT STATUS ⁽²⁾	DEFINITIONS
Objective data	Development	This data sheet contains data from the objective specification for product development. Philips Semiconductors reserves the right to change the specification in any manner without notice.
Preliminary data	Qualification	This data sheet contains data from the preliminary specification. Supplementary data will be published at a later date. Philips Semiconductors reserves the right to change the specification without notice, in order to improve the design and supply the best possible product.
Product data	Production	This data sheet contains data from the product specification. Philips Semiconductors reserves the right to make changes at any time in order to improve the design, manufacturing and supply. Changes will be communicated according to the Customer Product/Process Change Notification (CPCN) procedure SNW-SQ-650A.

Notes

1. Please consult the most recently issued data sheet before initiating or completing a design.
2. The product status of the device(s) described in this data sheet may have changed since this data sheet was published. The latest information is available on the Internet at URL <http://www.semiconductors.philips.com>.

DEFINITIONS

Short-form specification — The data in a short-form specification is extracted from a full data sheet with the same type number and title. For detailed information see the relevant data sheet or data handbook.

Limiting values definition — Limiting values given are in accordance with the Absolute Maximum Rating System (IEC 60134). Stress above one or more of the limiting values may cause permanent damage to the device. These are stress ratings only and operation of the device at these or at any other conditions above those given in the Characteristics sections of the specification is not implied. Exposure to limiting values for extended periods may affect device reliability.

Application information — Applications that are described herein for any of these products are for illustrative purposes only. Philips Semiconductors make no representation or warranty that such applications will be suitable for the specified use without further testing or modification.

DISCLAIMERS

Life support applications — These products are not designed for use in life support appliances, devices, or systems where malfunction of these products can reasonably be expected to result in personal injury. Philips Semiconductors customers using or selling these products for use in such applications do so at their own risk and agree to fully indemnify Philips Semiconductors for any damages resulting from such application.

Right to make changes — Philips Semiconductors reserves the right to make changes, without notice, in the products, including circuits, standard cells, and/or software, described or contained herein in order to improve design and/or performance. Philips Semiconductors assumes no responsibility or liability for the use of any of these products, conveys no licence or title under any patent, copyright, or mask work right to these products, and makes no representations or warranties that these products are free from patent, copyright, or mask work right infringement, unless otherwise specified.

Philips Semiconductors – a worldwide company

Contact information

For additional information please visit <http://www.semiconductors.philips.com>. Fax: +31 40 27 24825

For sales offices addresses send e-mail to: sales.addresses@www.semiconductors.philips.com.

© Koninklijke Philips Electronics N.V. 2002

SCA74

All rights are reserved. Reproduction in whole or in part is prohibited without the prior written consent of the copyright owner.

The information presented in this document does not form part of any quotation or contract, is believed to be accurate and reliable and may be changed without notice. No liability will be accepted by the publisher for any consequence of its use. Publication thereof does not convey nor imply any license under patent- or other industrial or intellectual property rights.

Printed in The Netherlands

613514/03/pp8

Date of release: 2002 Jul 04

Document order number: 9397 750 09764

Let's make things better.

**Philips
Semiconductors**



PHILIPS