

Nominal breakdown voltage $V_N$	800	V
Initial values <sup>2)</sup> Static breakdown voltage $V_S$ <sup>1)</sup> First ignition value $V_{S, FTE}$ after 24 hours in darkness Following ignition values $V_{S, FIV}$	$\leq 950$ 704 ... 896	V V
Electrical life time <sup>3)</sup> Breakdown voltage $V_B$ First ignition value $V_{B, FTE}$ after 24 hours in darkness Ignition time $t_i$ at $V_0$ during life Following ignition values $V_{B, FIV}$	$\leq 1000$ $\leq 60$ 680 ... 920	V ms V
Switching operations at $-40; +150$ °C at $+25; +125$ °C	40 000 100 000	Ignitions Ignitions
Test circuit parameters Open circuit voltage $V_0$ Loading resistance R Discharge capacitance C Inductance L Discharge peak current $I_P$	1000 68 100 0.5 $\sim 400$	V k $\Omega$ nF $\mu$ H A
General technical data Insulation resistance at 100 V Early ignition values between 500 ... 680 V Breakdown time Maximum switching frequency Maximum loading current Weight	$> 100$ $\leq 1$ $\leq 50$ 400 50 $\sim 2$	M $\Omega$ % ns Hz mA g
Marking, blue	<b>EPCOS 800 WWY O</b> 800 - Nominal voltage WW - Calendar week of production Y - Year of production O - Non radioactive	

<sup>1)</sup> At delivery AQL 0,65 level II, DIN ISO 2859

<sup>2)</sup> Page 2, Fig. 1 and 2

<sup>3)</sup> Page 2, Fig. 3 and 4

**Fig. 1:** QC- test circuit (100% outgoing inspection)

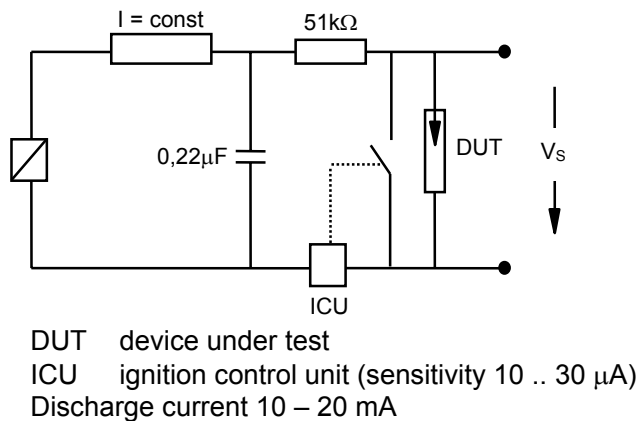

**Fig. 2:** Explanation of measurands

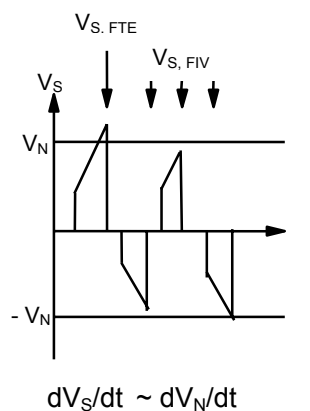

**Fig. 3:** QC- test circuit (sampling inspection at 25 °C)

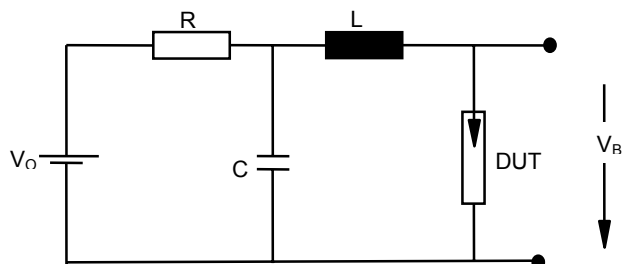

**Fig. 4:** Explanation of measurands

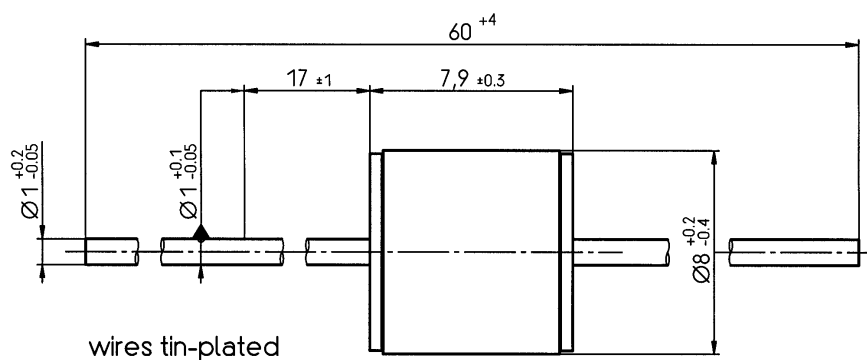
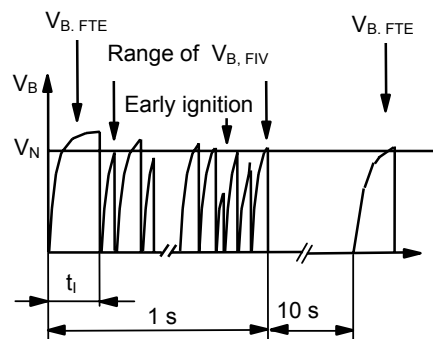

Not to scale  
 Dimensions in mm  
 Non controlled document

© EPCOS AG 2002. Reproduction, publication and dissemination of this data sheet, enclosures hereto and the information contained therein without EPCOS' prior express consent is prohibited.  
 Purchase orders are subject to the General Conditions for the Supply of Products and Services of the Electrical and Electronics Industry recommended by the ZVEI (German Electrical and Electronic Manufacturers' Association), unless otherwise agreed.