

Silicon Variable Capacitance Diode for Electronic Tuning of BS and CS Tuners

Description

The 1T379 is a variable capacitance diode designed for the electronic tuning of BS and CS tuners, and it has a super miniature package.

Features

- Super miniature package
- Small series resistance 1.50 Ω Max. (f=470 MHz)
- Large capacitance ratio 12.0 Typ. (C₁/C₂₅)
- Small capacitance 0.60 pF Max. (V_R=25 V)

Structure

Silicon epitaxial planar-type diode

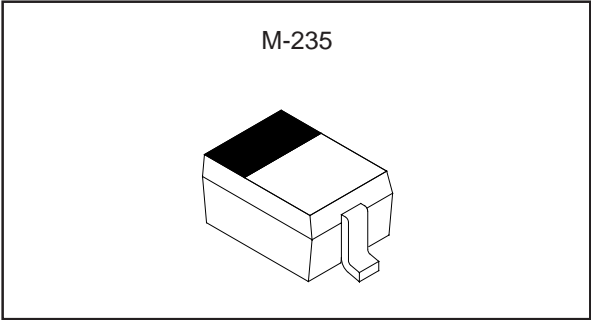

Absolute Maximum Ratings (Ta=25 °C)

- Reverse voltage V_R 30 V
- Maximum reverse voltage V_{RM} 35 V
(R_L≥10 kΩ)
- Operating temperature Topr -20 to +75 °C
- Storage temperature Tstg -65 to +150 °C

Electrical Characteristics

(Ta=25 °C)

Item	Symbol	Conditions	Min.	Typ.	Max.	Unit
Reverse current	I _R	V _R =25 V			10	nA
Reverse voltage	V _R	I _R =1 μA	30			V
Diode capacitance	C ₁	V _R =1 V, f=1 MHz	6.0		7.2	pF
	C ₂₅	V _R =25 V, f=1 MHz	0.5		0.6	pF
Capacitance ratio	C ₁ /C ₂₅	f=1 MHz	10.0	12.0		
Series resistance	r _s	V _R =5 V, f=470 MHz			1.50	Ω
Capacitance deviation in a matching group	ΔC	V _R =1 to 25 V, f=1 MHz			6	%

Sony reserves the right to change products and specifications without prior notice. This information does not convey any license by any implication or otherwise under any patents or other right. Application circuits shown, if any, are typical examples illustrating the operation of the devices. Sony cannot assume responsibility for any problems arising out of the use of these circuits.

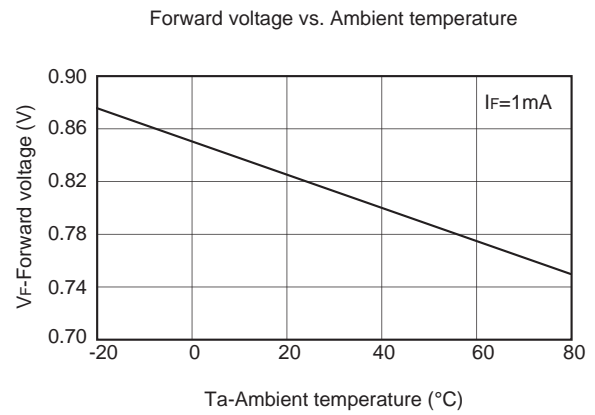
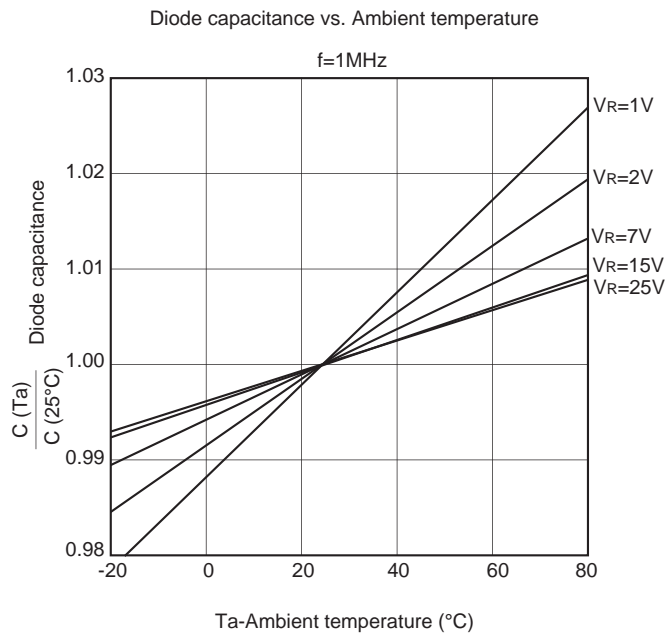
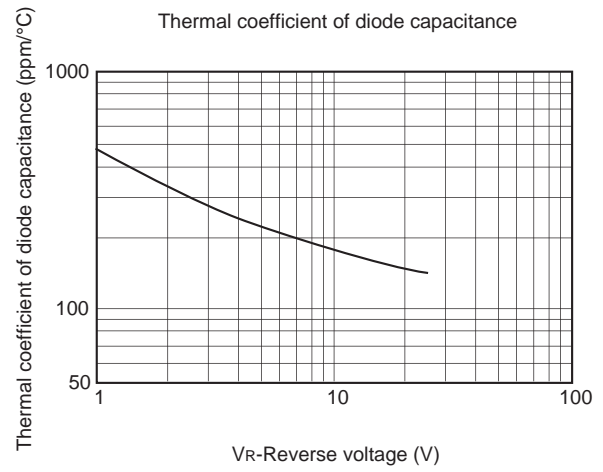
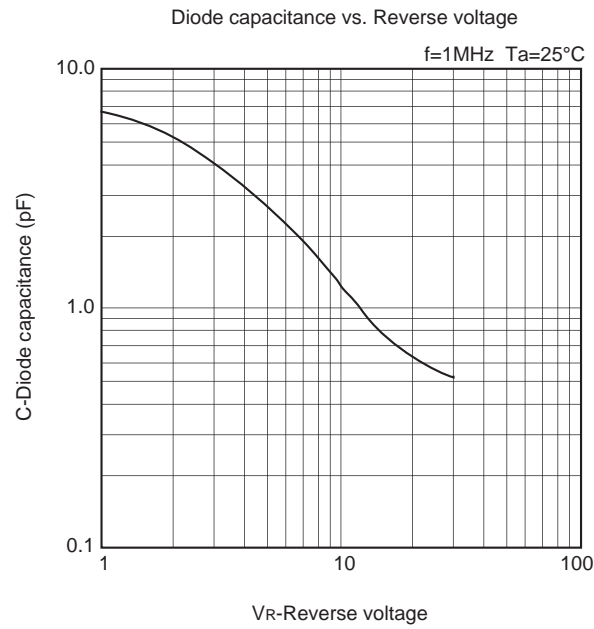

Reverse voltage vs. Ambient temperature

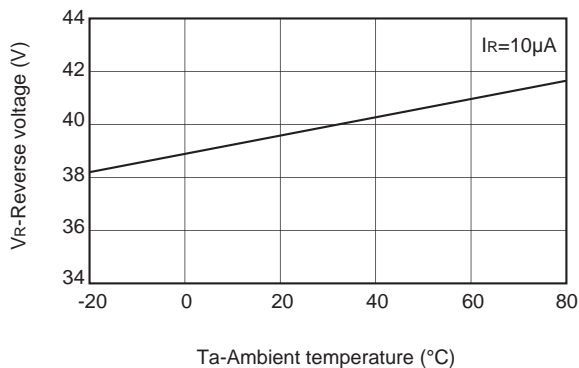

Reverse current vs. Ambient temperature

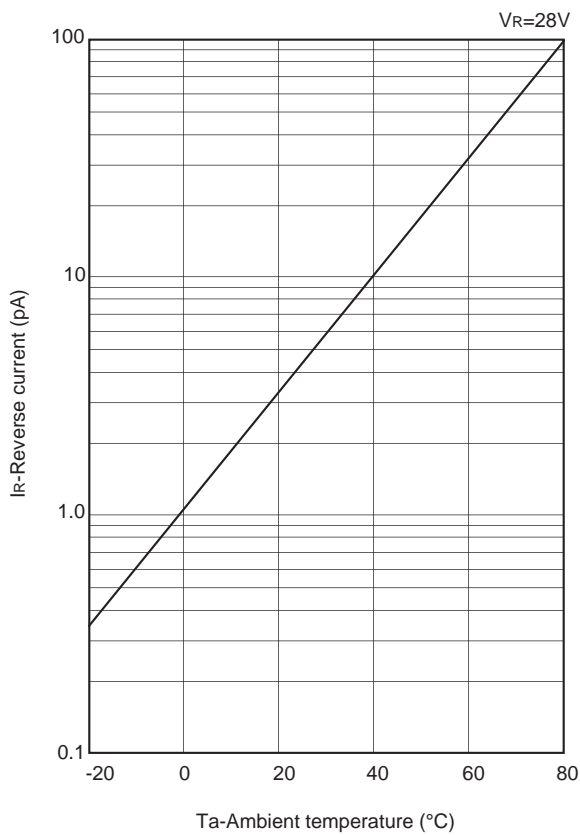

Reverse current vs. Reverse voltage

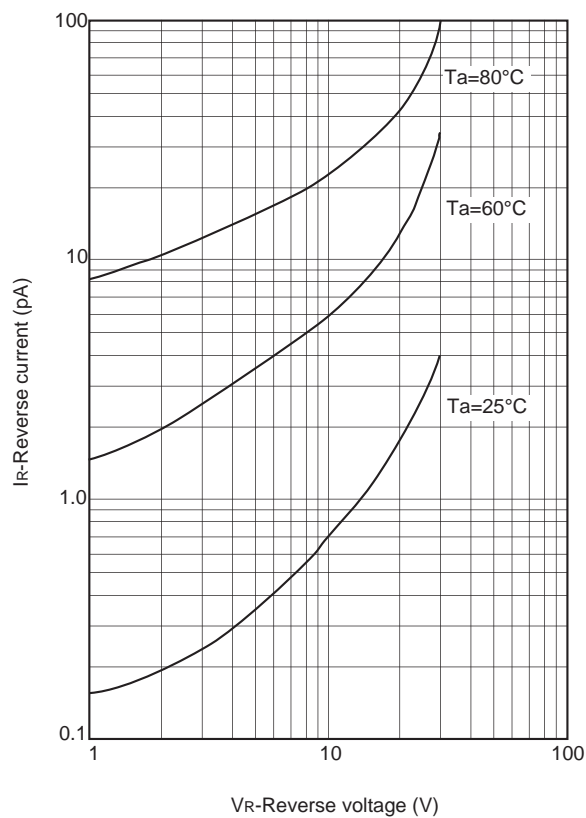

Package Outline Unit : mm

M-235

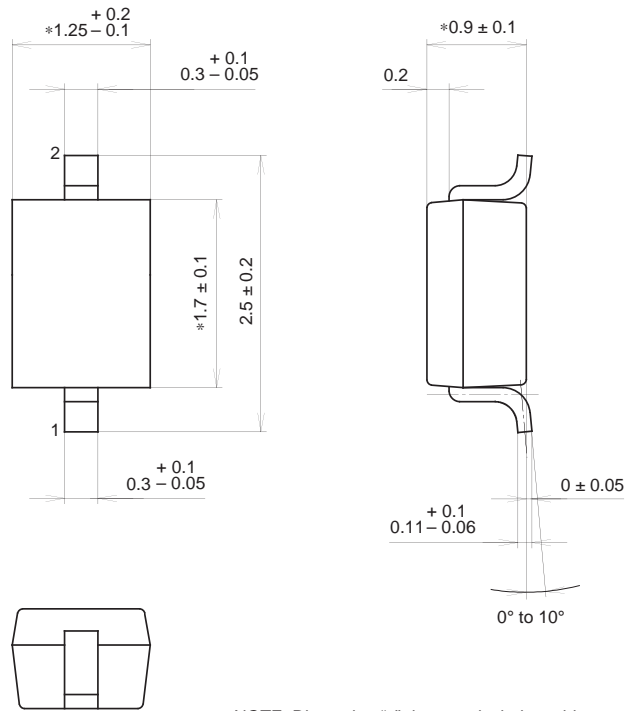

NOTE: Dimension "*" does not include mold protrusion.

SONY CODE	M-235
EIAJ CODE	—
JEDEC CODE	—

PACKAGE WEIGHT	0.1g
----------------	------

Marking

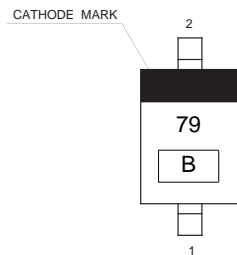

Notes

- 1) B: Lot No. (Year and Month of manufacture)
 Year; Last one digit
 Month; A, B, C (for Oct. to Dec.)
 1 to 9 (for Jan. to Sept.)