

**Features**

- Advanced Process Technology
- Ultra Low On-Resistance
- 175°C Operating Temperature
- Fast Switching
- Repetitive Avalanche Allowed up to Tjmax

**Description**

Specifically designed for Automotive applications, this HEXFET® Power MOSFET utilizes the latest processing techniques to achieve extremely low on-resistance per silicon area. Additional features of this design are a 175°C junction operating temperature, fast switching speed and improved repetitive avalanche rating. These features combine to make this design an extremely efficient and reliable device for use in Automotive applications and a wide variety of other applications.

**HEXFET® Power MOSFET**

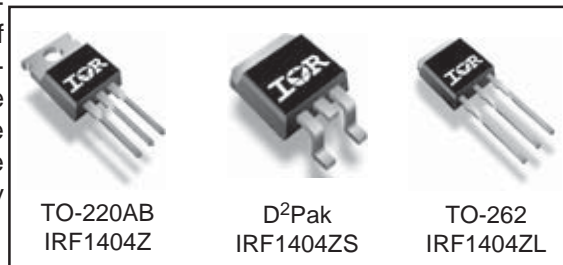
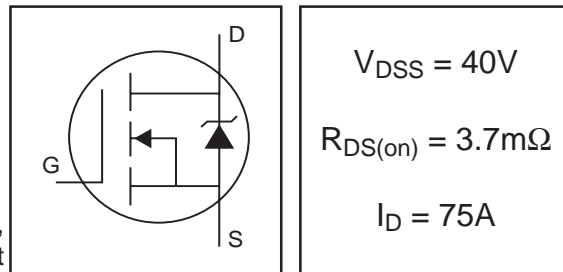

**Absolute Maximum Ratings**

|                              | Parameter  | Max.                     | Units |
|------------------------------|--|--------------------------|-------|
| $I_D @ T_C = 25^\circ C$     | Continuous Drain Current, $V_{GS} @ 10V$ (Silicon Limited) | 190                      | A     |
| $I_D @ T_C = 100^\circ C$    | Continuous Drain Current, $V_{GS} @ 10V$                   | 130                      |       |
| $I_D @ T_C = 25^\circ C$     | Continuous Drain Current, $V_{GS} @ 10V$ (Package Limited) | 75                       |       |
| $I_{DM}$                     | Pulsed Drain Current ①                                     | 750                      |       |
| $P_D @ T_C = 25^\circ C$     | Power Dissipation  | 220                      | W     |
|                              | Linear Derating Factor                                     | 1.5                      | W/°C  |
| $V_{GS}$                     | Gate-to-Source Voltage                                     | $\pm 20$                 | V     |
| $E_{AS}$ (Thermally limited) | Single Pulse Avalanche Energy ②                            | 320                      | mJ    |
| $E_{AS}$ (Tested )           | Single Pulse Avalanche Energy Tested Value ③               | 480                      |       |
| $I_{AR}$                     | Avalanche Current ④  | See Fig.12a, 12b, 15, 16 | A     |
| $E_{AR}$                     | Repetitive Avalanche Energy ⑤                              |                          | mJ    |
| $T_J$                        | Operating Junction and                                     | -55 to + 175             | °C    |
| $T_{STG}$                    | Storage Temperature Range                                  |                          |       |
|                              | Soldering Temperature, for 10 seconds                      |                          |       |
|                              | Mounting Torque, 6-32 or M3 screw ⑦                        | 10 lbf•in (1.1N•m)       |       |

**Thermal Resistance**

|                 | Parameter                            | Typ. | Max. | Units |
|-----------------|--------------------------------------|------|------|-------|
| $R_{\theta JC}$ | Junction-to-Case                     | —    | 0.65 | °C/W  |
| $R_{\theta CS}$ | Case-to-Sink, Flat Greased Surface ⑧ | 0.50 | —    |       |
| $R_{\theta JA}$ | Junction-to-Ambient ⑨                | —    | 62   |       |
| $R_{\theta JA}$ | Junction-to-Ambient (PCB Mount) ⑩    | —    | 40   |       |

## Electrical Characteristics @ T<sub>J</sub> = 25°C (unless otherwise specified)

|                                      | Parameter                            | Min. | Typ.  | Max. | Units | Conditions  |
|--------------------------------------|--------------------------------------|------|-------|------|-------|---|
| V <sub>(BR)DSS</sub>                 | Drain-to-Source Breakdown Voltage    | 40   | —     | —    | V     | V <sub>GS</sub> = 0V, I <sub>D</sub> = 250μA                                |
| ΔV <sub>(BR)DSS/ΔT<sub>J</sub></sub> | Breakdown Voltage Temp. Coefficient  | —    | 0.033 | —    | V/°C  | Reference to 25°C, I <sub>D</sub> = 1mA                                     |
| R <sub>DS(on)</sub>                  | Static Drain-to-Source On-Resistance | —    | 2.7   | 3.7  | mΩ    | V <sub>GS</sub> = 10V, I <sub>D</sub> = 75A ③                               |
| V <sub>GS(th)</sub>                  | Gate Threshold Voltage               | 2.0  | —     | 4.0  | V     | V <sub>DS</sub> = V <sub>GS</sub> , I <sub>D</sub> = 250μA                  |
| g <sub>fs</sub>                      | Forward Transconductance             | 170  | —     | —    | V     | V <sub>DS</sub> = 25V, I <sub>D</sub> = 75A                                 |
| I <sub>DSS</sub>                     | Drain-to-Source Leakage Current      | —    | —     | 20   | μA    | V <sub>DS</sub> = 40V, V <sub>GS</sub> = 0V                                 |
|                                      |                                      | —    | —     | 250  |       | V <sub>DS</sub> = 40V, V <sub>GS</sub> = 0V, T <sub>J</sub> = 125°C         |
| I <sub>GSS</sub>                     | Gate-to-Source Forward Leakage       | —    | —     | 200  | nA    | V <sub>GS</sub> = 20V   |
|                                      | Gate-to-Source Reverse Leakage       | —    | —     | -200 |       | V <sub>GS</sub> = -20V  |
| Q <sub>g</sub>                       | Total Gate Charge                    | —    | 100   | 150  |       | I <sub>D</sub> = 75A  |
| Q <sub>gs</sub>                      | Gate-to-Source Charge                | —    | 31    | —    | nC    | V <sub>DS</sub> = 32V   |
| Q <sub>gd</sub>                      | Gate-to-Drain ("Miller") Charge      | —    | 42    | —    |       | V <sub>GS</sub> = 10V ③   |
| t <sub>d(on)</sub>                   | Turn-On Delay Time                   | —    | 18    | —    |       | V <sub>DD</sub> = 20V   |
| t <sub>r</sub>                       | Rise Time                            | —    | 110   | —    |       | I <sub>D</sub> = 75A  |
| t <sub>d(off)</sub>                  | Turn-Off Delay Time                  | —    | 36    | —    | ns    | R <sub>G</sub> = 3.0 Ω  |
| t <sub>f</sub>                       | Fall Time                            | —    | 58    | —    |       | V <sub>GS</sub> = 10V ③   |
| L <sub>D</sub>                       | Internal Drain Inductance            | —    | 4.5   | —    | nH    | Between lead,<br>6mm (0.25in.)<br>from package<br>and center of die contact |
| L <sub>S</sub>                       | Internal Source Inductance           | —    | 7.5   | —    |       |   |
| C <sub>iss</sub>                     | Input Capacitance                    | —    | 4340  | —    |       | V <sub>GS</sub> = 0V  |
| C <sub>oss</sub>                     | Output Capacitance                   | —    | 1030  | —    |       | V <sub>DS</sub> = 25V   |
| C <sub>rss</sub>                     | Reverse Transfer Capacitance         | —    | 550   | —    | pF    | f = 1.0MHz  |
| C <sub>oss</sub>                     | Output Capacitance                   | —    | 3300  | —    |       | V <sub>GS</sub> = 0V, V <sub>DS</sub> = 1.0V, f = 1.0MHz                    |
| C <sub>oss</sub>                     | Output Capacitance                   | —    | 920   | —    |       | V <sub>GS</sub> = 0V, V <sub>DS</sub> = 32V, f = 1.0MHz                     |
| C <sub>oss eff.</sub>                | Effective Output Capacitance         | —    | 1350  | —    |       | V <sub>GS</sub> = 0V, V <sub>DS</sub> = 0V to 32V ④                         |

## Source-Drain Ratings and Characteristics

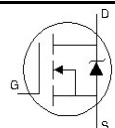
|                 | Parameter                                 | Min.   | Typ. | Max. | Units | Conditions  |
|-----------------|---|--|------|------|-------|---|
| I <sub>S</sub>  | Continuous Source Current<br>(Body Diode) | —  | —    | 75   | A     | MOSFET symbol<br>showing the<br>integral reverse<br>p-n junction diode.               |
| I <sub>SM</sub> | Pulsed Source Current<br>(Body Diode) ①   | —  | —    | 750  |       |  |
| V <sub>SD</sub> | Diode Forward Voltage                     | —  | —    | 1.3  | V     | T <sub>J</sub> = 25°C, I <sub>S</sub> = 75A, V <sub>GS</sub> = 0V ③                   |
| t <sub>rr</sub> | Reverse Recovery Time                     | —  | 28   | 42   | ns    | T <sub>J</sub> = 25°C, I <sub>F</sub> = 75A, V <sub>DD</sub> = 20V                    |
| Q <sub>rr</sub> | Reverse Recovery Charge                   | —  | 34   | 51   | nC    | di/dt = 100A/μs ③   |
| t <sub>on</sub> | Forward Turn-On Time                      | Intrinsic turn-on time is negligible (turn-on is dominated by LS+LD) |      |      |       |   |

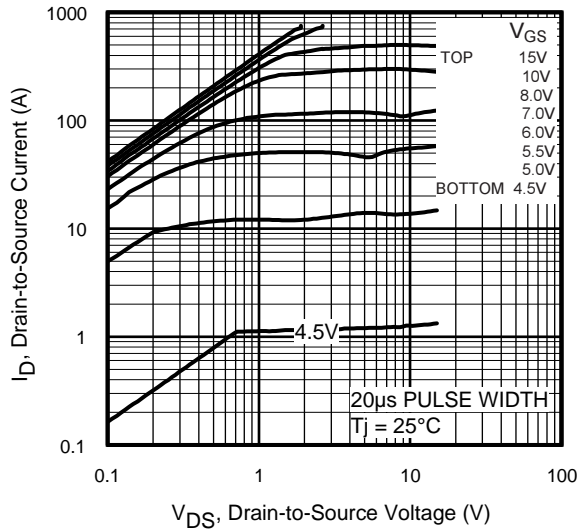

**Fig 1.** Typical Output Characteristics

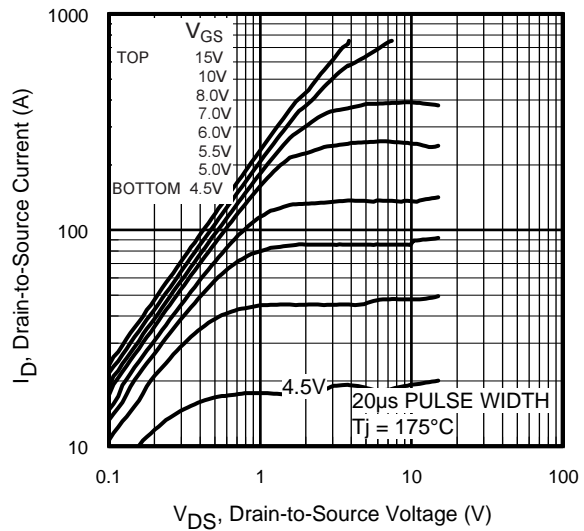

**Fig 2.** Typical Output Characteristics

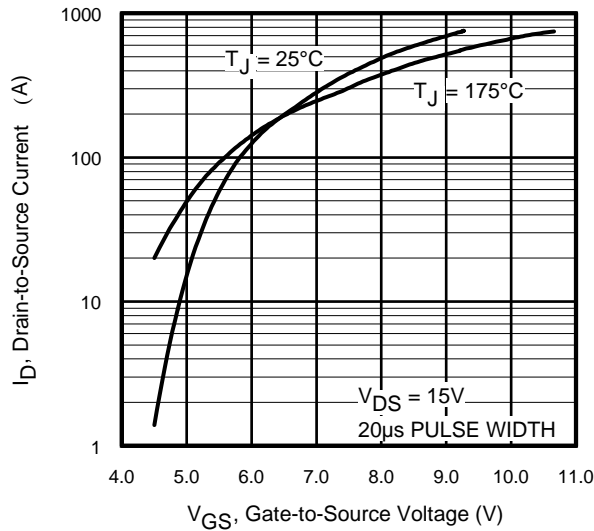

**Fig 3.** Typical Transfer Characteristics

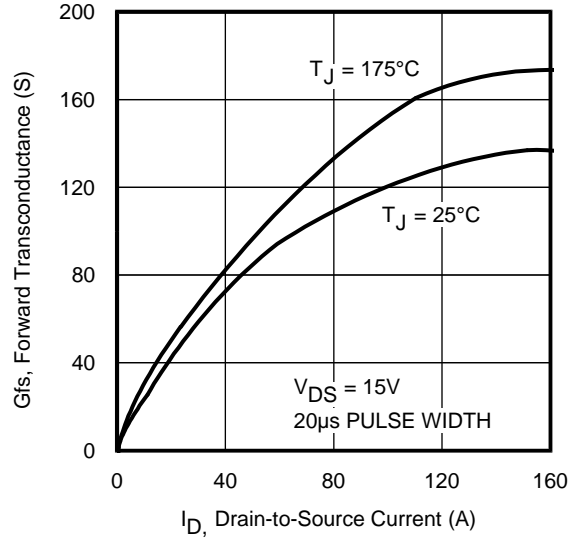

**Fig 4.** Typical Forward Transconductance Vs. Drain Current

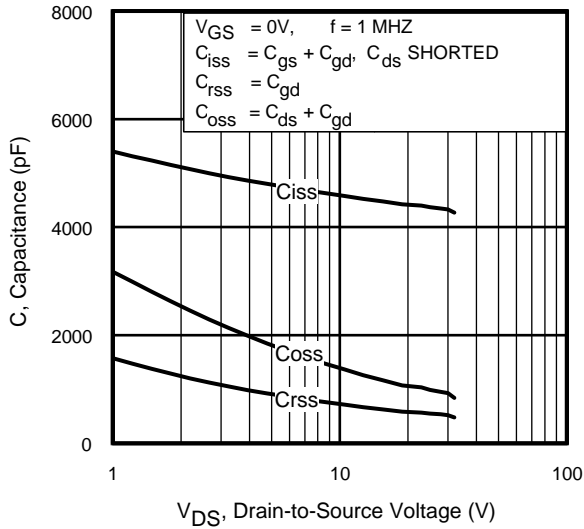

**Fig 5.** Typical Capacitance Vs. Drain-to-Source Voltage

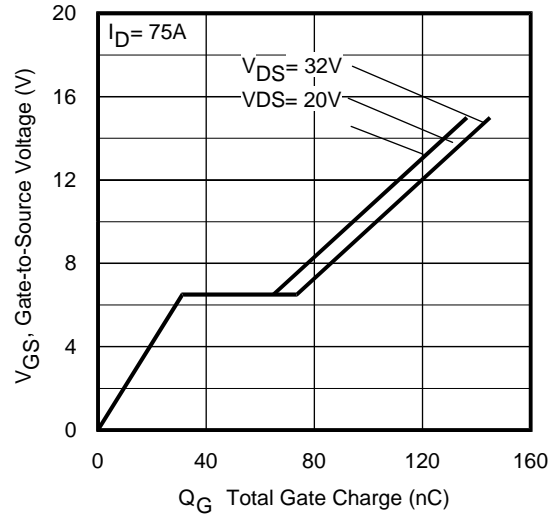

**Fig 6.** Typical Gate Charge Vs. Gate-to-Source Voltage

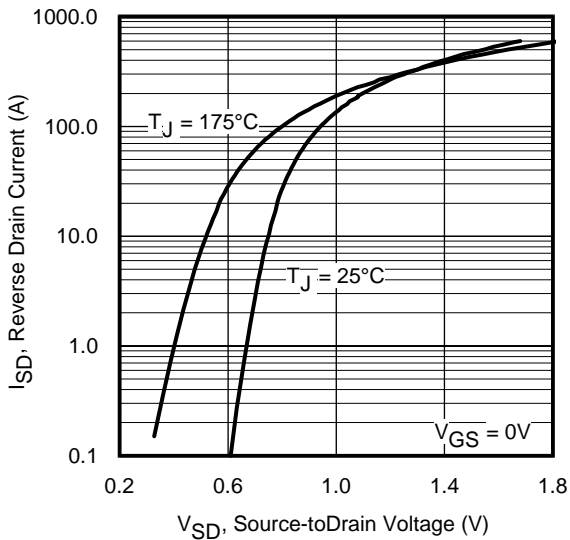

**Fig 7.** Typical Source-Drain Diode Forward Voltage

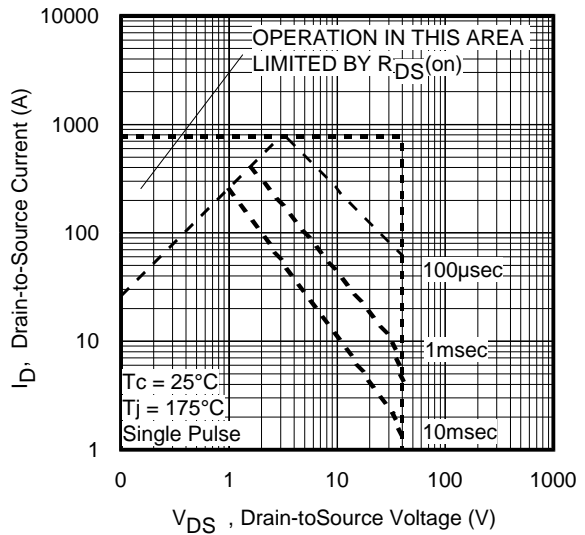

**Fig 8.** Maximum Safe Operating Area

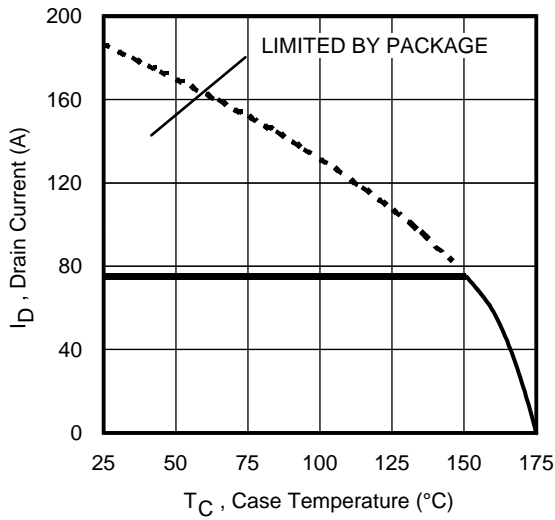

Fig 9. Maximum Drain Current Vs. Case Temperature

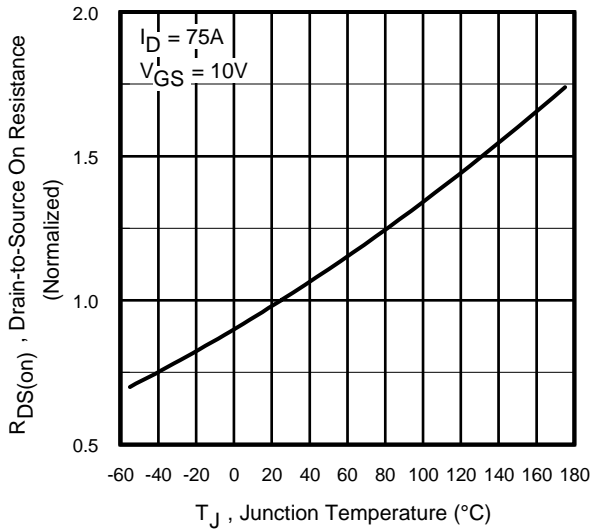

Fig 10. Normalized On-Resistance Vs. Temperature

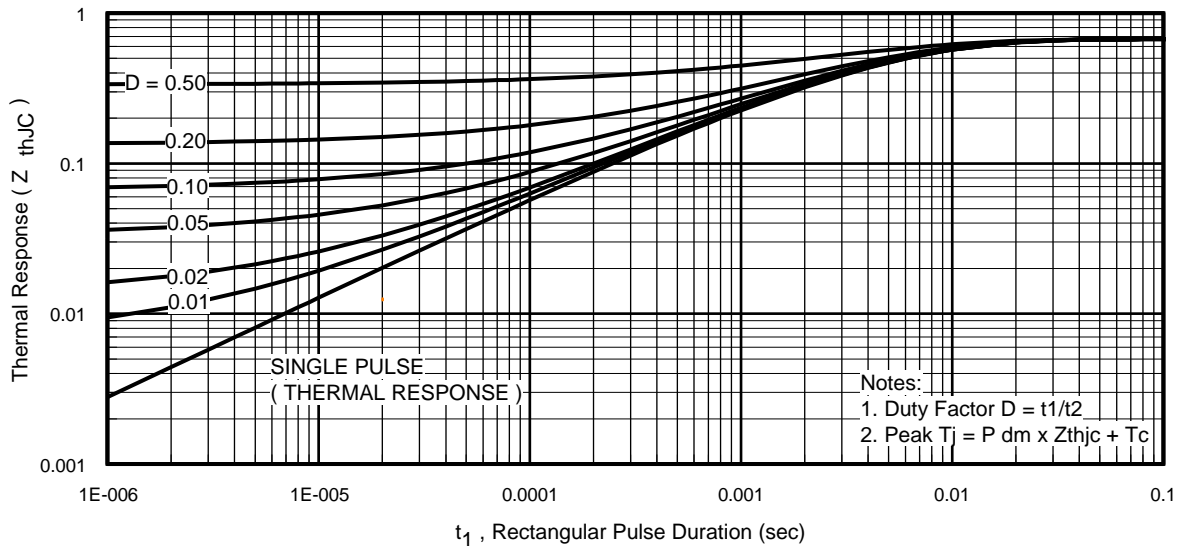

Fig 11. Maximum Effective Transient Thermal Impedance, Junction-to-Case

# IRF1404ZS\_L

International  
**IR** Rectifier



**Fig 12a.** Unclamped Inductive Test Circuit



**Fig 12b.** Unclamped Inductive Waveforms

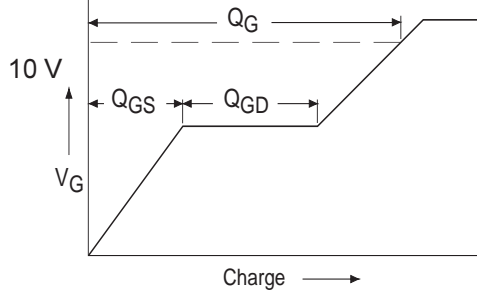

**Fig 13a.** Basic Gate Charge Waveform

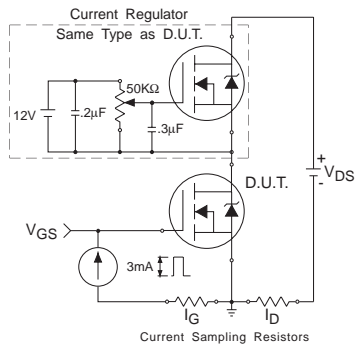

**Fig 13b.** Gate Charge Test Circuit

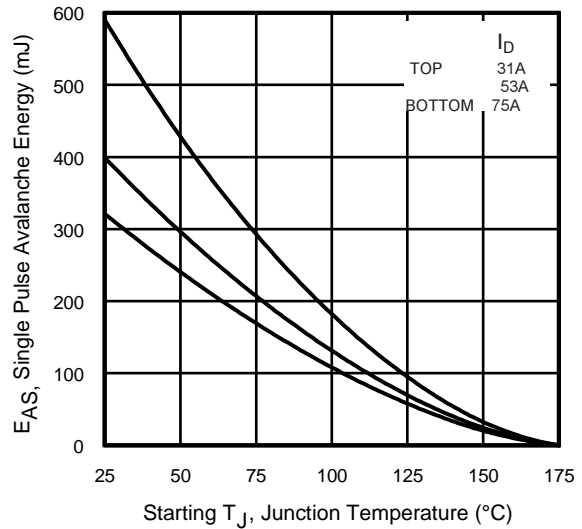

**Fig 12c.** Maximum Avalanche Energy Vs. Drain Current

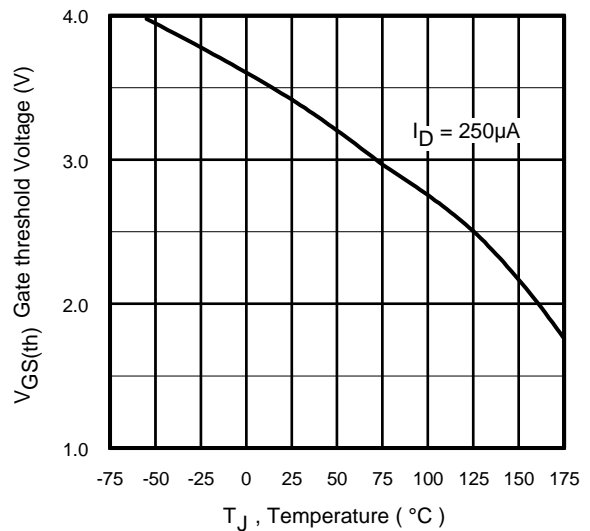

**Fig 14.** Threshold Voltage Vs. Temperature

www.irf.com

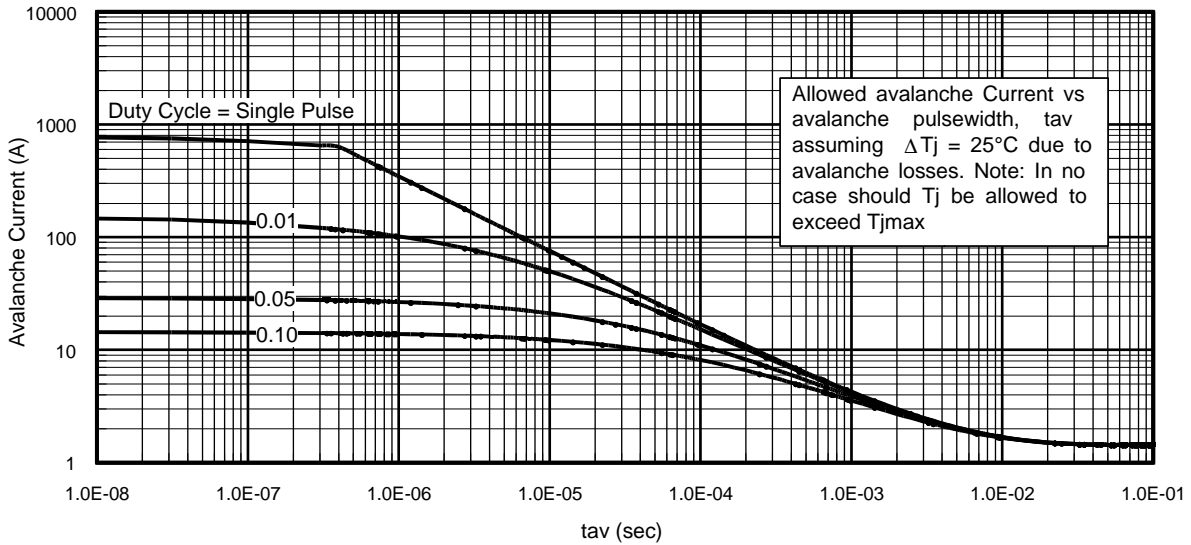

Fig 15. Typical Avalanche Current Vs.Pulsewidth

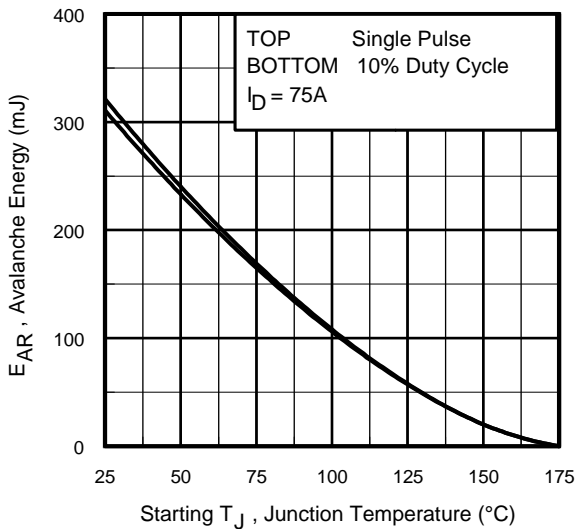

Fig 16. Maximum Avalanche Energy Vs. Temperature

**Notes on Repetitive Avalanche Curves , Figures 15, 16:**  
**(For further info, see AN-1005 at www.irf.com)**

1. Avalanche failures assumption:  
Purely a thermal phenomenon and failure occurs at a temperature far in excess of  $T_{jmax}$ . This is validated for every part type.
2. Safe operation in Avalanche is allowed as long as  $T_{jmax}$  is not exceeded.
3. Equation below based on circuit and waveforms shown in Figures 12a, 12b.
4.  $P_{D(ave)}$  = Average power dissipation per single avalanche pulse.
5.  $BV$  = Rated breakdown voltage (1.3 factor accounts for voltage increase during avalanche).
6.  $I_{av}$  = Allowable avalanche current.
7.  $\Delta T$  = Allowable rise in junction temperature, not to exceed  $T_{jmax}$  (assumed as 25°C in Figure 15, 16).  
 $t_{av}$  = Average time in avalanche.  
 $D$  = Duty cycle in avalanche =  $t_{av} \cdot f$   
 $Z_{thJC}(D, t_{av})$  = Transient thermal resistance, see figure 11)

$$P_{D(ave)} = 1/2 ( 1.3 \cdot BV \cdot I_{av} ) = \Delta T / Z_{thJC}$$

$$I_{av} = 2\Delta T / [1.3 \cdot BV \cdot Z_{th}]$$

$$E_{AS(AR)} = P_{D(ave)} \cdot t_{av}$$

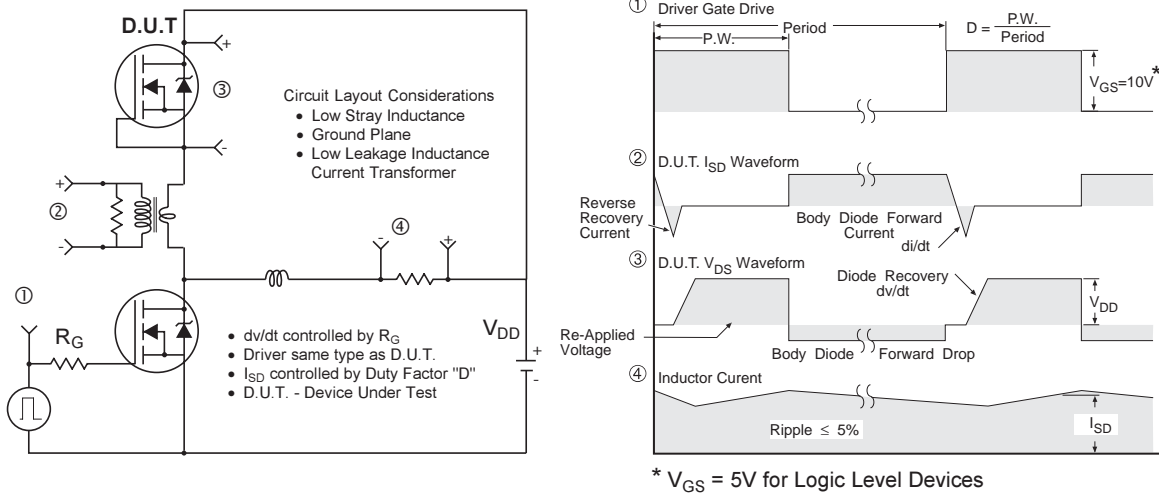

**Fig 17. Peak Diode Recovery  $dv/dt$  Test Circuit for N-Channel HEXFET® Power MOSFETs**

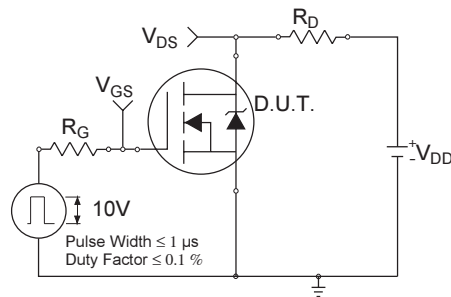

**Fig 18a. Switching Time Test Circuit**

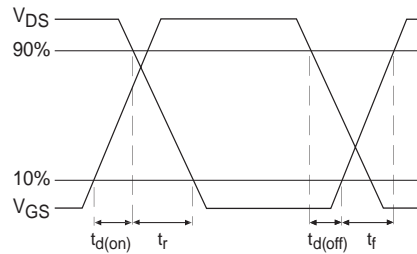
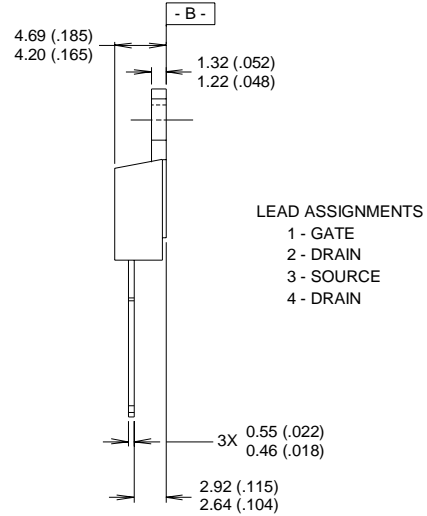
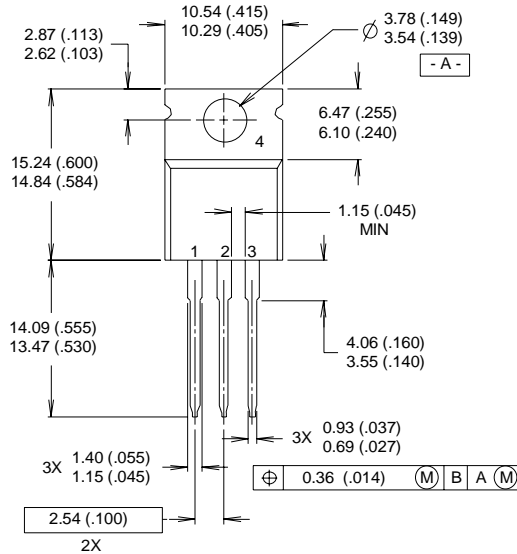

**Fig 18b. Switching Time Waveforms**



## TO-220AB Package Outline

Dimensions are shown in millimeters (inches)



**NOTES:**

- 1 DIMENSIONING & TOLERANCING PER ANSI Y14.5M, 1982.
- 2 CONTROLLING DIMENSION : INCH
- 3 OUTLINE CONFORMS TO JEDEC OUTLINE TO-220AB.
- 4 HEATSINK & LEAD MEASUREMENTS DO NOT INCLUDE BURRS.

## TO-220AB Part Marking Information

EXAMPLE: THIS IS AN IRF1010  
 LOT CODE 1789  
 ASSEMBLED ON WW 19, 1997  
 IN THE ASSEMBLY LINE "C"

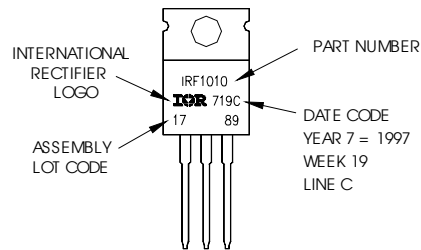

**For GB Production**

EXAMPLE: THIS IS AN IRF1010  
 LOT CODE 1789  
 ASSEMBLED ON WW 19, 1997  
 IN THE ASSEMBLY LINE "C"

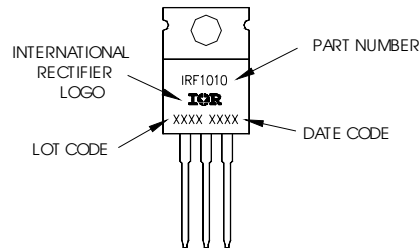

# IRF1404ZS\_L

## D<sup>2</sup>Pak Package Outline

Dimensions are shown in millimeters (inches)

International  
**IR** Rectifier

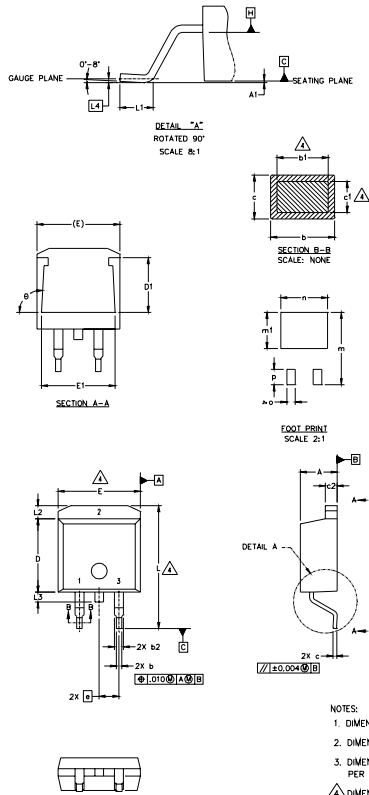

| SYMBOL | DIMENSIONS  |       |          |      | NOTES |
|--------|-------------|-------|----------|------|-------|
|        | MILLIMETERS |       | INCHES   |      |       |
|        | MIN.        | MAX.  | MIN.     | MAX. |       |
| A      | 4.06        | 4.83  | .160     | .190 | 4     |
| A1     |             | 0.127 |          | .005 |       |
| b      | 0.51        | 0.99  | .020     | .039 |       |
| b1     | 0.51        | 0.89  | .020     | .035 |       |
| b2     | 1.14        | 1.40  | .045     | .055 | 4     |
| c      | 0.43        | 0.63  | .017     | .025 |       |
| c1     | 0.38        | 0.74  | .015     | .029 |       |
| c2     | 1.14        | 1.40  | .045     | .055 | 3     |
| D      | 8.51        | 9.65  | .335     | .380 |       |
| D1     | 5.33        |       | .210     |      | 3     |
| E      | 9.65        | 10.67 | .380     | .420 |       |
| E1     | 6.22        |       | .245     |      |       |
| e      | 2.54 BSC    |       | .100 BSC |      |       |
| L      | 14.61       | 15.88 | .575     | .625 |       |
| L1     | 1.78        | 2.79  | .070     | .110 |       |
| L2     |             | 1.65  |          | .065 |       |
| L3     | 1.27        | 1.78  | .050     | .070 |       |
| L4     | 0.25 BSC    |       | .010 BSC |      |       |
| m      | 17.78       |       | .700     |      |       |
| m1     | 8.89        |       | .350     |      |       |
| n      | 11.43       |       | .450     |      |       |
| o      | 2.08        |       | .082     |      |       |
| p      | 3.81        |       | .150     |      |       |
| theta  | 90°         | 93°   | 90°      | 93°  |       |

### LEAD ASSIGNMENTS

| HEXFET     | IGBTs, CoPACK | DIODES      |
|------------|---------------|-------------|
| 1.- GATE   | 1.- GATE      | 1.- ANODE * |
| 2.- DRAIN  | 2.- COLLECTOR | 2.- CATHODE |
| 3.- SOURCE | 3.- EMITTER   | 3.- ANODE   |

\* PART DEPENDENT.

### NOTES:

- DIMENSIONING AND TOLERANCING PER ASME Y14.5M-1994
- DIMENSIONS ARE SHOWN IN MILLIMETERS [INCHES]
- DIMENSION D & E DO NOT INCLUDE MOLD FLASH. MOLD FLASH SHALL NOT EXCEED 0.127 [0.005"] PER SIDE. THESE DIMENSIONS ARE MEASURED AT THE OUTMOST EXTREMES OF THE PLASTIC BODY.
- DIMENSION b1 AND c1 APPLY TO BASE METAL ONLY.
- CONTROLLING DIMENSION: INCH.

## D<sup>2</sup>Pak Part Marking Information

EXAMPLE: THIS IS AN IRF530S WITH  
LOT CODE 8024  
ASSEMBLED ON WW 02, 2000  
IN THE ASSEMBLY LINE "L"

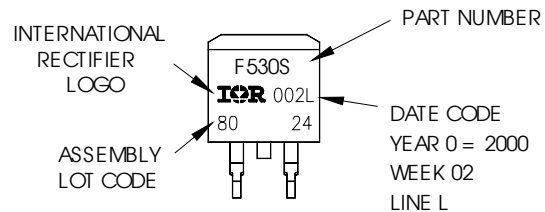

For GB Production

EXAMPLE: THIS IS AN IRF530S WITH  
LOT CODE 8024  
ASSEMBLED ON WW 02, 2000  
IN THE ASSEMBLY LINE "L"

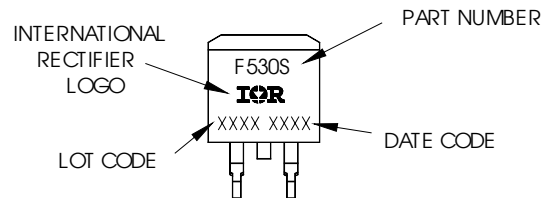

## TO-262 Package Outline

Dimensions are shown in millimeters (inches)

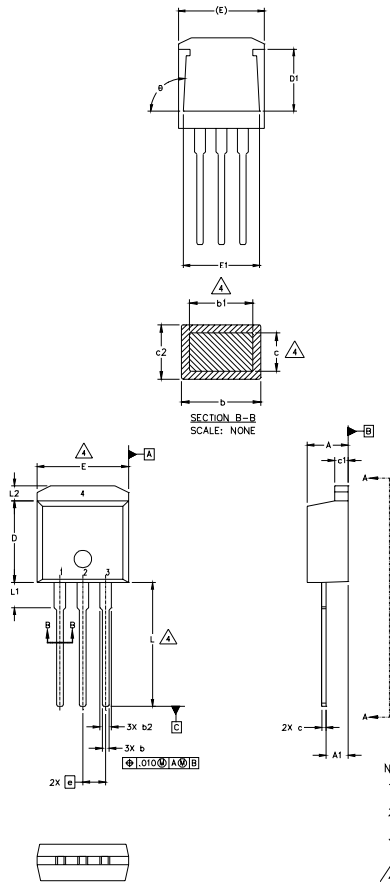

| SYMBOL | DIMENSIONS  |       |          |      | NOTES |
|--------|-------------|-------|----------|------|-------|
|        | MILLIMETERS |       | INCHES   |      |       |
|        | MIN.        | MAX.  | MIN.     | MAX. |       |
| A      | 4.06        | 4.83  | .160     | .190 | 4     |
| A1     | 2.03        | 2.92  | .080     | .115 |       |
| b      | 0.51        | 0.99  | .020     | .039 |       |
| b1     | 0.51        | 0.89  | .020     | .035 |       |
| b2     | 1.14        | 1.40  | .045     | .055 | 4     |
| c      | 0.38        | 0.63  | .015     | .025 |       |
| c1     | 1.14        | 1.40  | .045     | .055 | 3     |
| c2     | 0.43        | .063  | .017     | .029 |       |
| D      | 8.51        | 9.65  | .335     | .380 |       |
| D1     | 5.33        |       | .210     |      | 3     |
| E      | 9.65        | 10.67 | .380     | .420 |       |
| E1     | 6.22        |       | .245     |      |       |
| e      | 2.54 BSC    |       | .100 BSC |      |       |
| L      | 13.46       | 14.09 | .530     | .555 |       |
| L1     | 3.56        | 3.71  | .140     | .146 |       |
| L2     |             | 1.65  |          | .065 |       |

### LEAD ASSIGNMENTS

| HEXFET     | IGBT         |
|------------|--------------|
| 1.- GATE   | 1- GATE      |
| 2.- DRAIN  | 2- COLLECTOR |
| 3.- SOURCE |              |
| 4.- DRAIN  |              |

- NOTES:
1. DIMENSIONING AND TOLERANCING PER ASME Y14.5M-1994
  2. DIMENSIONS ARE SHOWN IN MILLIMETERS [INCHES].
  3. DIMENSION D & E DO NOT INCLUDE MOLD FLASH. MOLD FLASH SHALL NOT EXCEED 0.127 [0.005"] PER SIDE. THESE DIMENSIONS ARE MEASURED AT THE OUTMOST EXTREMES OF THE PLASTIC BODY.
  4. DIMENSION b1 AND c1 APPLY TO BASE METAL ONLY.
  5. CONTROLLING DIMENSION: INCH.

## TO-262 Part Marking Information

EXAMPLE: THIS IS AN IRL3103L  
LOT CODE 1789  
ASSEMBLED ON WW 19, 1997  
IN THE ASSEMBLY LINE "C"

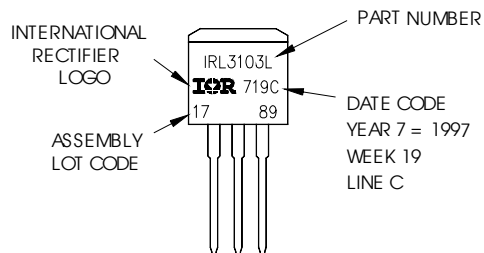

# IRF1404ZS\_L

International  
**IR** Rectifier

## D<sup>2</sup>Pak Tape & Reel Information

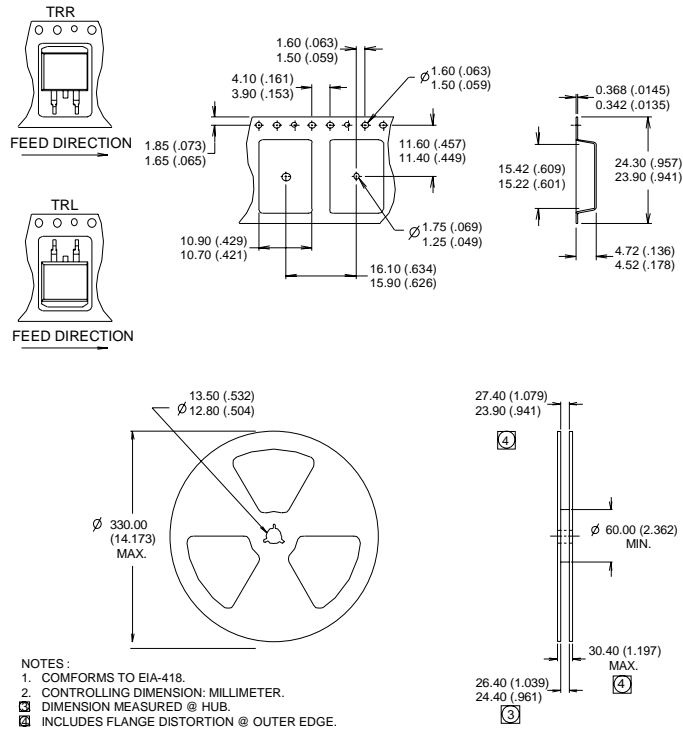

### Notes:

- ① Repetitive rating; pulse width limited by max. junction temperature. (See fig. 11).
- ② Limited by  $T_{Jmax}$ , starting  $T_J = 25^\circ C$ ,  $L = 0.11mH$ ,  $R_G = 25\Omega$ ,  $I_{AS} = 75A$ ,  $V_{GS} = 10V$ . Part not recommended for use above this value.
- ③ Pulse width  $\leq 1.0ms$ ; duty cycle  $\leq 2\%$ .
- ④  $C_{OSS}$  eff. is a fixed capacitance that gives the same charging time as  $C_{OSS}$  while  $V_{DS}$  is rising from 0 to 80%  $V_{DSS}$ .
- ⑤ Limited by  $T_{Jmax}$ , see Fig.12a, 12b, 15, 16 for typical repetitive avalanche performance.
- ⑥ This value determined from sample failure population. 100% tested to this value in production.
- ⑦ This is only applied to TO-220AB package.
- ⑧ This is applied to D<sup>2</sup>Pak, when mounted on 1" square PCB (FR-4 or G-10 Material). For recommended footprint and soldering techniques refer to application note #AN-994.

**TO-220AB package is not recommended for Surface Mount Application.**

Data and specifications subject to change without notice.  
This product has been designed and qualified for the Automotive [Q101]market.  
Qualification Standards can be found on IR's Web site.

International  
**IR** Rectifier

**IR WORLD HEADQUARTERS:** 233 Kansas St., El Segundo, California 90245, USA Tel: (310) 252-7105  
TAC Fax: (310) 252-7903

Visit us at [www.irf.com](http://www.irf.com) for sales contact information. 08/03

[www.irf.com](http://www.irf.com)

Note: For the most current drawings please refer to the IR website at:  
<http://www.irf.com/package/>