

LM3354

Regulated 90mA Buck-Boost Switched Capacitor DC/DC Converter

General Description

The LM3354 is a CMOS switched capacitor DC/DC converter that produces a regulated output voltage by automatically stepping up (boost) or stepping down (buck) the input voltage. It accepts an input voltage between 2.5V and 5.5V. The LM3354 is available with standard output voltages of 1.8V, 3.3V, 4.1V (ideal for white LED applications), and 5.0V. If other output voltage options between 1.8V and 5.0V are desired, please contact your National Semiconductor representative.

The LM3354's proprietary buck-boost architecture enables up to 90mA of load current at an average efficiency greater than 75%. Typical operating current is only 375 μ A and the typical shutdown current is only 2.3 μ A.

The LM3354 is available in a 10-pin MSOP package. This package has a maximum height of only 1.1 mm.

The high efficiency of the LM3354, low operating and shutdown currents, small package size, and the small size of the overall solution make this device ideal for battery powered, portable, and hand-held applications.

See the LM3352 for up to 200mA of output current or the LM3355 for up to 50mA of output current.

Features

- Regulated V_{OUT} with $\pm 3\%$ (5.0V, 4.1V, and 3.3V options) or $\pm 4\%$ (1.8V option) accuracy
- Standard output voltages of 1.8V, 3.3V, 4.1V, and 5.0V
- Custom output voltages available from 1.8V to 5.0V in 100 mV increments with volume order
- 2.5V to 5.5V input voltage range
- Up to 90mA (5.0V, 4.1V, and 1.8V options) or 70mA (3.3V option) output current
- >75% average efficiency
- Uses few, low-cost external components
- Very small solution size
- 375 μ A typical operating current
- 2.3 μ A typical shutdown current
- 1 MHz typical switching frequency
- Architecture and control methods provide high load current and good efficiency
- MSOP-10 package
- Over-temperature protection

Applications

- White LED display backlights
- 1-cell Lilon battery-operated equipment including PDAs, hand-held PCs, cellular phones
- Flat panel displays
- Hand-held instruments
- Li-Ion, NiCd, NiMH, or alkaline battery powered systems

Typical Operating Circuit

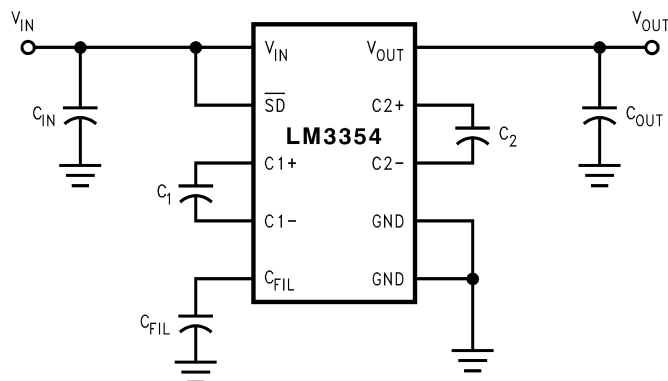

Connection Diagram

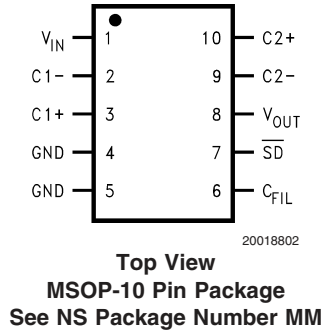

Ordering Information

Order Number	Package Type	NSC Package Drawing	Supplied As
LM3354MMX-5.0	MSOP-10	MUB10A	3.5k Units, Tape and Reel
LM3354MM-5.0	MSOP-10	MUB10A	1k Units, Tape and Reel
LM3354MMX-4.1	MSOP-10	MUB10A	3.5k Units, Tape and Reel
LM3354MM-4.1	MSOP-10	MUB10A	1k Units, Tape and Reel
LM3354MMX-3.3	MSOP-10	MUB10A	3.5k Units, Tape and Reel
LM3354MM-3.3	MSOP-10	MUB10A	1k Units, Tape and Reel
LM3354MMX-1.8	MSOP-10	MUB10A	3.5k Units, Tape and Reel
LM3354MM-1.8	MSOP-10	MUB10A	1k Units, Tape and Reel

Pin Description

Pin Number	Name	Function
1	V_{IN}	Input Supply Voltage
2	C1-	Negative Terminal for C1
3	C1+	Positive Terminal for C1
4	GND	Ground
5	GND	Ground
6	C_{FIL}	Filter Capacitor, a 1 μ F capacitor is recommended.
7	\overline{SD}	Shutdown, active low
8	V_{OUT}	Regulated Output Voltage
9	C2-	Negative Terminal for C2
10	C2+	Positive Terminal for C2

Absolute Maximum Ratings (Note 1)

If Military/Aerospace specified devices are required, please contact the National Semiconductor Sales Office/Distributors for availability and specifications.

All Pins	-0.5V to 5.6V
Power Dissipation ($T_A = 25^\circ\text{C}$) (Note 2)	Internally Limited
T_{JMAX} (Note 2)	150°C
θ_{JA} (Note 2)	250°C/W
Storage Temperature	-65°C to +150°C
Lead Temperature (Soldering, 5 sec.)	260°C
ESD Rating (Note 3)	
Human Body Model	1.5 kV
Machine Model	100V

Operating Ratings

Input Voltage (V_{IN})	2.5V to 5.5V
Output Voltage (V_{OUT})	1.8V to 5.0V
Ambient Temperature (T_A) (Note 2)	-40°C to +85°C
Junction Temperature (T_J) (Note 2)	-40°C to +120°C

Electrical Characteristics

Limits in standard typeface are for $T_A = 25^\circ\text{C}$, and limits in **boldface** type apply over the full operating temperature range. Unless otherwise specified: $C_1 = C_2 = 0.33 \mu\text{F}$; $C_{IN} = 10 \mu\text{F}$; $C_{OUT} = 10 \mu\text{F}$; $C_{FIL} = 1 \mu\text{F}$; $V_{IN} = 3.5\text{V}$.

Parameter	Conditions	Min (Note 5)	Typ (Note 4)	Max (Note 5)	Units
LM3354-5.0					
Output Voltage (V_{OUT})	$3.4\text{V} < V_{IN} < 5.5\text{V}$; $1 \text{ mA} < I_{LOAD} < 90 \text{ mA}$	4.85/ 4.8	5.0	5.15/ 5.2	V
	$3.1\text{V} < V_{IN} < 5.5\text{V}$; $1 \text{ mA} < I_{LOAD} < 55 \text{ mA}$	4.85/ 4.8	5.0	5.15/ 5.2	
	$2.9\text{V} < V_{IN} < 5.5\text{V}$; $1 \text{ mA} < I_{LOAD} < 30 \text{ mA}$	4.85/ 4.8	5.0	5.15/ 5.2	
Efficiency	$I_{LOAD} = 15 \text{ mA}$		85		%
	$I_{LOAD} = 40 \text{ mA}$, $V_{IN} = 3.8\text{V}$		85		
Output Voltage Ripple (Peak-to-Peak)	$I_{LOAD} = 50 \text{ mA}$ $C_{OUT} = 10 \mu\text{F}$ ceramic		75		mV_{P-P}
LM3354-4.1					
Output Voltage (V_{OUT})	$2.9\text{V} < V_{IN} < 5.5\text{V}$; $1 \text{ mA} < I_{LOAD} < 90 \text{ mA}$	3.977/ 3.936	4.1	4.223/ 4.264	V
	$2.5\text{V} < V_{IN} < 5.5\text{V}$; $1 \text{ mA} < I_{LOAD} < 40 \text{ mA}$	3.977/ 3.936	4.1	4.223/ 4.264	
Efficiency	$I_{LOAD} = 15 \text{ mA}$		80		%
	$I_{LOAD} = 70 \text{ mA}$		75		
Output Voltage Ripple (Peak-to-Peak)	$I_{LOAD} = 50 \text{ mA}$ $C_{OUT} = 10 \mu\text{F}$ ceramic		75		mV_{P-P}

Electrical Characteristics (Continued)

Limits in standard typeface are for $T_A = 25^\circ\text{C}$, and limits in **boldface** type apply over the full operating temperature range. Unless otherwise specified: $C_1 = C_2 = 0.33\ \mu\text{F}$; $C_{\text{IN}} = 10\ \mu\text{F}$; $C_{\text{OUT}} = 10\ \mu\text{F}$; $C_{\text{FIL}} = 1\ \mu\text{F}$; $V_{\text{IN}} = 3.5\text{V}$.

Parameter	Conditions	Min (Note 5)	Typ (Note 4)	Max (Note 5)	Units
LM3354-3.3					
Output Voltage (V _{OUT})	2.9V < V _{IN} < 5.5V; 1 mA < I _{LOAD} < 70 mA	3.201/ 3.168	3.3	3.399/ 3.432	V
	2.5V < V _{IN} < 5.5V; 1 mA < I _{LOAD} < 70 mA	3.201/ 3.168	3.3	3.399/ 3.432	
Efficiency	I _{LOAD} = 15 mA		90		%
	I _{LOAD} = 70 mA		70		
Output Voltage Ripple (Peak-to-Peak)	I _{LOAD} = 50 mA C _{OUT} = 10 μF ceramic		75		mV _{P-P}
LM3354-1.8					
Output Voltage (V _{OUT})	2.9V < V _{IN} < 5.5V; 1 mA < I _{LOAD} < 90 mA	1.728/ 1.710	1.8	1.872/ 1.89	V
	2.5V < V _{IN} < 5.5V; 1 mA < I _{LOAD} < 80 mA	1.728/ 1.710	1.8	1.872/ 1.89	
Efficiency	I _{LOAD} = 15 mA		75		%
	I _{LOAD} = 70 mA		70		
Output Voltage Ripple (Peak-to-Peak)	I _{LOAD} = 50 mA C _{OUT} = 10 μF ceramic		25		mV _{P-P}
LM3354-ALL OUTPUT VOLTAGE VERSIONS					
Operating Quiescent Current	Measured at Pin V _{IN} ; I _{LOAD} = 0A (Note 6)		375	475	μA
Shutdown Quiescent Current	SD Pin at 0V (Note 7)		2.3	5	μA
Switching Frequency		0.6	1	1.4	MHz
SD Input Threshold Low	2.5V < V _{IN} < 5.5V			0.2 V_{IN}	V
SD Input Threshold High	2.5V < V _{IN} < 5.5V	0.8 V_{IN}			V
SD Input Current	Measured at SD Pin; SD Pin = V _{IN} = 5.5V		0.3		μA

Note 1: "Absolute Maximum Ratings" indicate limits beyond which damage to the device may occur. Operating Ratings are conditions for which the device is intended to be functional, but device parameter specifications may not be guaranteed. For guaranteed specifications and test conditions, see "Electrical Characteristics".

Note 2: As long as $T_A \leq +85^\circ\text{C}$, all electrical characteristics hold true and the junction temperature should remain below $+120^\circ\text{C}$ except for the 5V output option. The 5V option requires that $T_A \leq +60^\circ\text{C}$.

Note 3: The human body model is a 100 pF capacitor discharged through a 1.5 kΩ resistor into each pin. The machine model is a 200 pF capacitor discharged directly into each pin.

Note 4: Typical numbers are at 25°C and represent the most likely norm.

Note 5: All limits guaranteed at room temperature (standard typeface) and at temperature extremes (bold typeface). All room temperature limits are 100% tested or guaranteed through statistical analysis. All limits at temperature extremes are guaranteed by correlation using standard Statistical Quality Control methods (SQC). All limits are used to calculate Average Outgoing Quality Level (AOQL).

Note 6: The V_{OUT} pin is forced to 200 mV above the typical V_{OUT}. This is to insure that the internal switches are off.

Note 7: The output capacitor C_{OUT} is fully discharged before measurement.

Typical Performance Characteristics

Unless otherwise specified $T_A = 25^\circ\text{C}$.

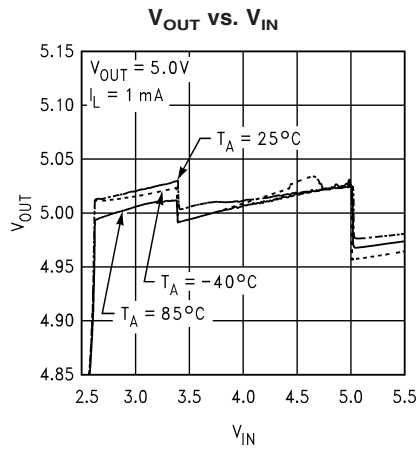

20018841

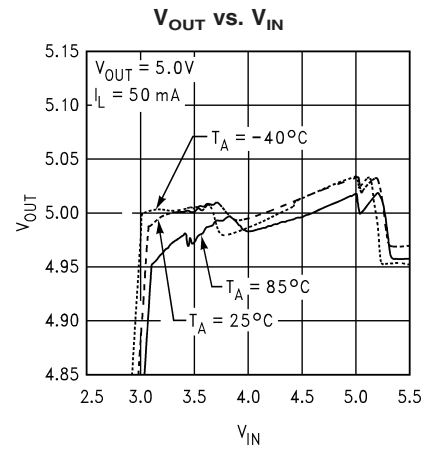

20018842

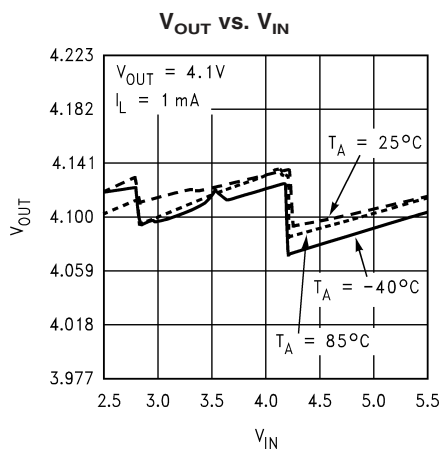

20018804

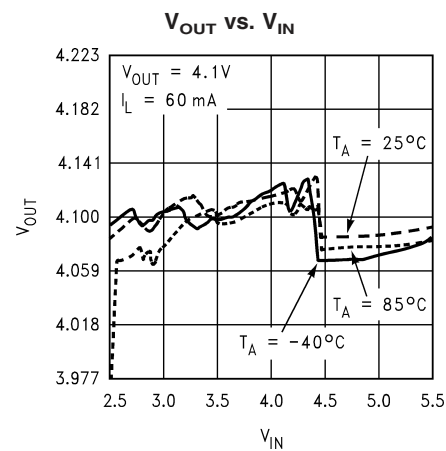

20018805

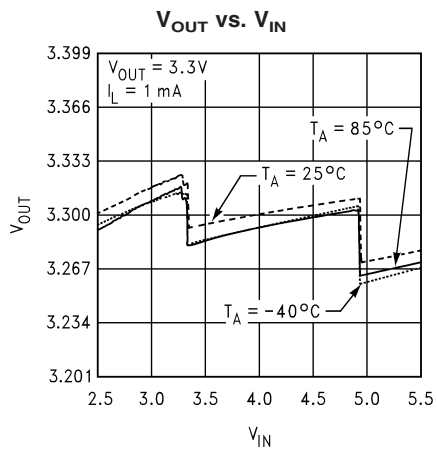

20018834

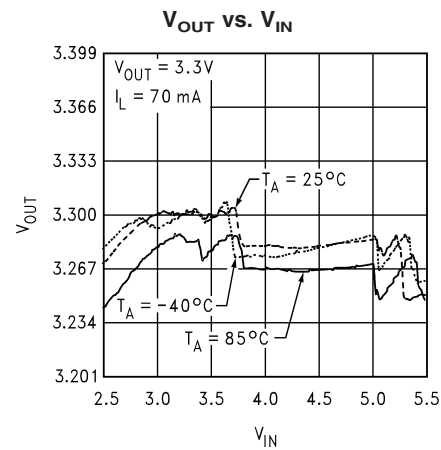

20018835

Typical Performance Characteristics Unless otherwise specified $T_A = 25^\circ\text{C}$. (Continued)

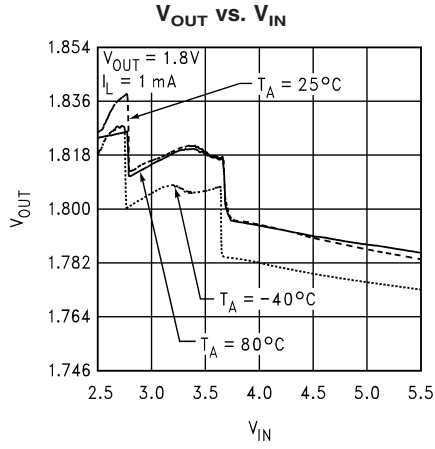

20018836

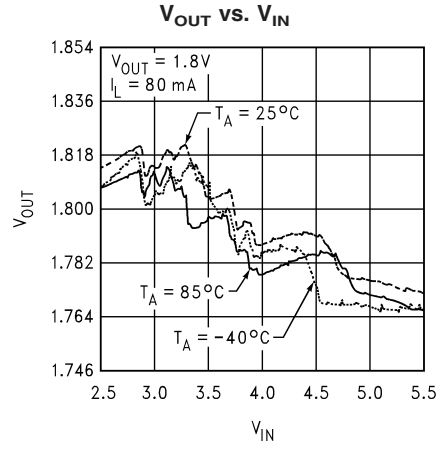

20018837

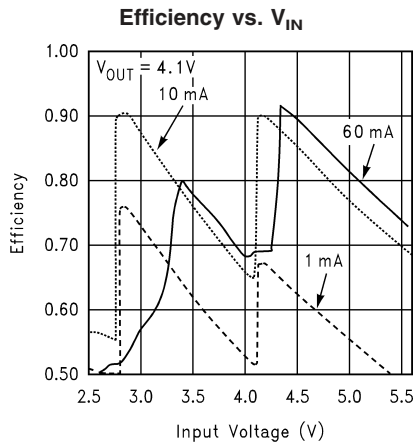

20018820

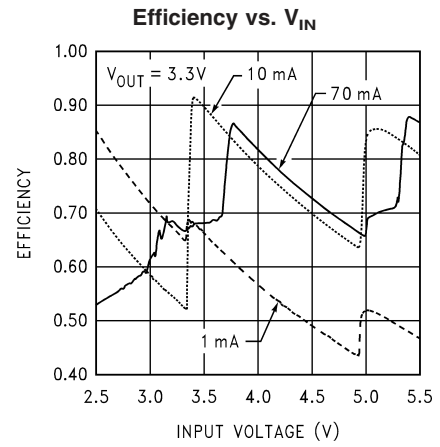

20018838

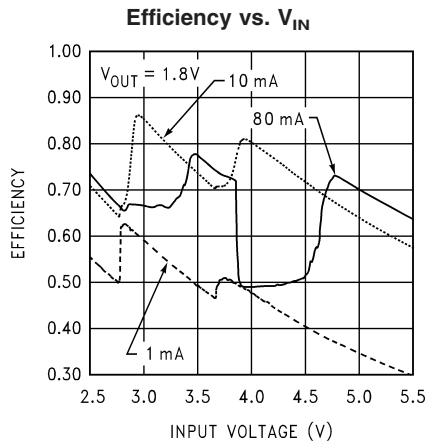

20018839

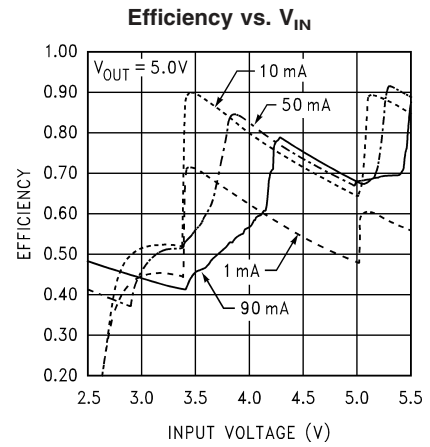

20018843

Typical Performance Characteristics Unless otherwise specified $T_A = 25^\circ\text{C}$. (Continued)

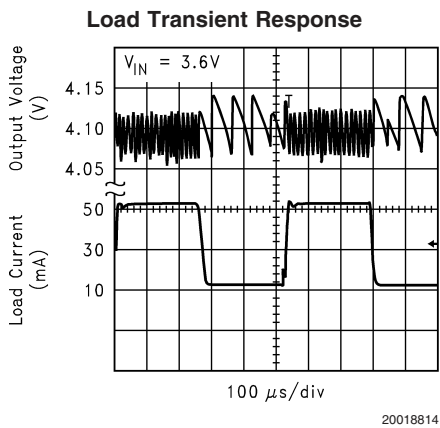
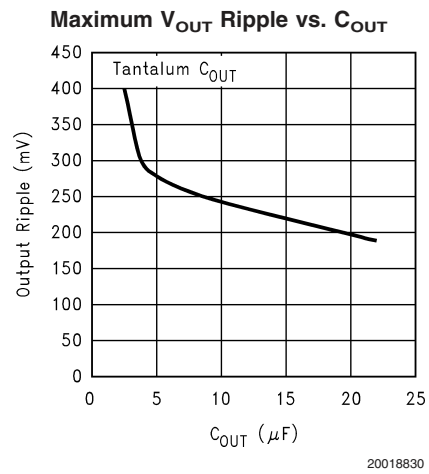
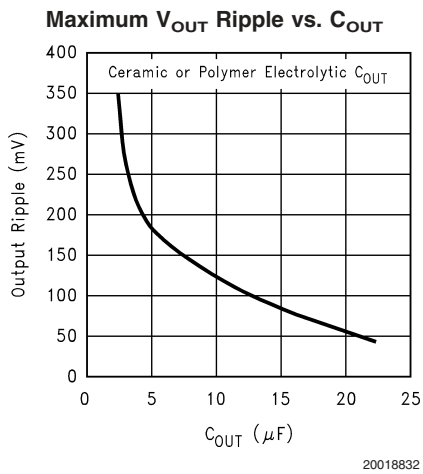
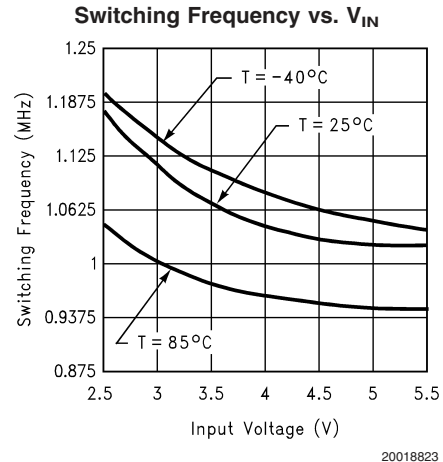
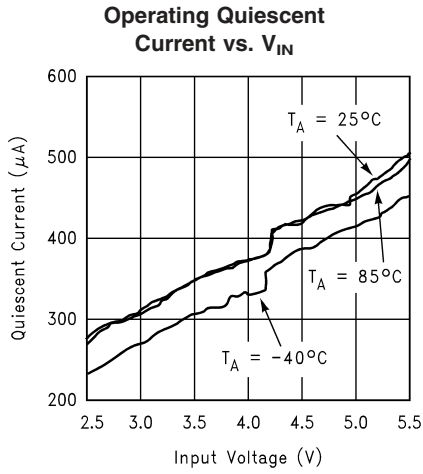

Applications Information

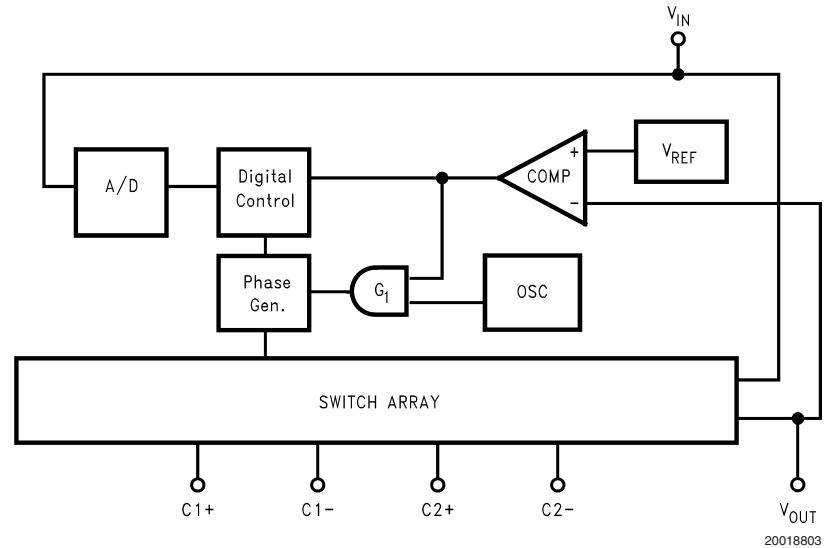

FIGURE 1. Block Diagram

Operating Principle

The LM3354 is designed to provide a step-up/step-down voltage regulation in battery powered systems. It combines switched capacitor circuitry, reference, comparator, and shutdown logic in a single 10-pin MSOP package. The LM3354 can provide a regulated voltage between 1.8V and 5.0V from an input voltage between 2.5V and 5.5V. It can supply a load current up to 90 mA (refer to *Electrical Characteristics*).

As shown in *Figure 1*, the LM3354 employs two feedback loops to provide regulation in the most efficient manner possible. The first loop is from V_{OUT} through the comparator COMP, the AND gate G_1 , the phase generator, and the switch array. The comparator's output is high when V_{OUT} is less than the reference V_{REF} . Regulation is provided by gating the clock to the switch array. In this manner, charge is transferred to the output only when needed. The second loop controls the gain configuration of the switch array. This loop consists of the comparator, the digital control block, the phase generator, and the switch array. The digital control block computes the most efficient gain from a set of five gains based on inputs from the A/D and the comparator. The gain signal is sent to the phase generator which then sends the appropriate timing and configuration signals to the switch array. This dual loop provides regulation over a wide range of loads efficiently.

Since efficiency is automatically optimized, the curves for V_{OUT} vs. V_{IN} and Efficiency vs. V_{IN} in the Typical Performance Characteristics section exhibit small variations. The reason is that as input voltage or output load changes, the digital control loops are making decisions on how to optimize efficiency. As the switch array is reconfigured, small variations in output voltage and efficiency result. In all cases where these small variations are observed, the part is operating correctly; minimizing output voltage changes and optimizing efficiency.

Charge Pump Capacitor Selection

A 0.33 μF ceramic capacitor is suggested for C1 and C2. To ensure proper operation over temperature variations, an X7R dielectric material is recommended.

Filter Capacitor Selection

a) CAPACITOR TECHNOLOGIES

The three major technologies of capacitors that can be used as filter capacitors for LM3354 are: i) tantalum, ii) ceramic and iii) polymer electrolytic technologies.

i) Tantalum

Tantalum capacitors are widely used in switching regulators. Tantalum capacitors have the highest CV rating of any technology; as a result, high values of capacitance can be obtained in relatively small package sizes. It is also possible to obtain high value tantalum capacitors in very low profile (<1.2 mm) packages. This makes the tantalums attractive for low-profile, small size applications. Tantalums also possess very good temperature stability; i.e., the change in the capacitance value, and impedance over temperature is relatively small. However, the tantalum capacitors have relatively high ESR values which can lead to higher voltage ripple and their frequency stability (variation over frequency) is not very good, especially at high frequencies (>1 MHz).

ii) Ceramic

Ceramic capacitors have the lowest ESR of the three technologies and their frequency stability is exceptionally good. These characteristics make the ceramics an attractive choice for low ripple, high frequency applications. However, the temperature stability of the ceramics is bad, except for the X7R and X5R dielectric types. High capacitance values (>1 μF) are achievable from companies such as Taiyo-yuden which are suitable for use with regulators. Ceramics are taller and larger than the tantalums of the same capacitance value.

Filter Capacitor Selection (Continued)

iii) Polymer Electrolytic

Polymer electrolytic is a third suitable technology. Polymer capacitors provide some of the best features of both the ceramic and the tantalum technologies. They provide very low ESR values while still achieving high capacitance values. However, their ESR is still higher than the ceramics,

and their capacitance value is lower than the tantalums of the same size. Polymers offer good frequency stability (comparable to ceramics) and good temperature stability (comparable to tantalums). The Aluminum Polymer Electrolytics offered by Cornell-Dubilier and Panasonic, and the POS-CAPs offered by Sanyo fall under this category.

Table 1 compares the features of the three capacitor technologies.

TABLE 1. Comparison of Capacitor Technologies

	Ceramic	Tantalum	Polymer Electrolytic
ESR	Lowest	High	Low
Relative Height	Low for Small Values (<10 μ F); Taller for Higher Values	Lowest	Low
Relative Footprint	Large	Small	Largest
Temperature Stability	X7R/X5R-Acceptable	Good	Good
Frequency Stability	Good	Acceptable	Good
V_{OUT} Ripple Magnitude @ <50 mA	Low	High	Low
V_{OUT} Ripple Magnitude @ >100 mA	Low	Slightly Higher	Low
dv/dt of V_{OUT} Ripple @ All Loads	Lowest	High	Low

b) CAPACITOR SELECTION

i) Output Capacitor (C_{OUT})

The output capacitor C_{OUT} directly affects the magnitude of the output ripple voltage so C_{OUT} should be carefully selected. The graphs titled V_{OUT} Ripple vs. C_{OUT} in the Typical Performance Characteristics section show how the ripple voltage magnitude is affected by the C_{OUT} value and the capacitor technology. These graphs are taken at the gain at which worst case ripple is observed. In general, the higher the value of C_{OUT} , the lower the output ripple magnitude. At lighter loads, the low ESR ceramics offer a much lower V_{OUT} ripple than the higher ESR tantalums of the same value. At higher loads, the ceramics offer a slightly lower V_{OUT} ripple magnitude than the tantalums of the same value. However, the dv/dt of the V_{OUT} ripple with the ceramics and polymer electrolytics is much lower than the tantalums under all load conditions. The tantalums are suggested for very low profile, small size applications. The ceramics and polymer electrolytics are a good choice for low ripple, low noise applications where size is less of a concern.

ii) Input Capacitor (C_{IN})

The input capacitor C_{IN} directly affects the magnitude of the input ripple voltage, and to a lesser degree the V_{OUT} ripple.

A higher value C_{IN} will give a lower V_{IN} ripple. To optimize low input and output ripple as well as size a 10 μ F polymer electrolytic or ceramic, or 15 μ F tantalum capacitor is recommended. This will ensure low input ripple at 90 mA load current. If lower currents will be used or higher input ripple can be tolerated then a smaller capacitor may be used to reduce the overall size of the circuit. The lower ESR ceramics and polymer electrolytics achieve a lower V_{IN} ripple than the higher ESR tantalums of the same value. Tantalums make a good choice for small size, very low profile applications. The ceramics and polymer electrolytics are a good choice for low ripple, low noise applications where size is less of a concern. The 10 μ F polymer electrolytics are physically much larger than the 15 μ F tantalums and 10 μ F ceramics.

iii) C_{FIL}

A 1 μ F, X7R ceramic capacitor should be connected to pin C_{FIL} . This capacitor provides the filtering needed for the internal supply rail of the LM3354.

Of the different capacitor technologies, a sample of vendors that have been verified as suitable for use with the LM3354 are shown in Table 2.

TABLE 2. Capacitor Vendor Information

	Manufacturer	Tel	Fax	Website
Ceramic	Taiyo-yuden	(408) 573-4150	(408) 573-4159	www.t-yuden.com
	AVX	(803) 448-9411	(803) 448-1943	www.avxcorp.com
	Sprague/Vishay	(207) 324-4140	(207) 324-7223	www.vishay.com
Tantalum	Nichicon	(847) 843-7500	(847) 843-2798	www.nichicon.com
Polymer Electrolytic	Cornell-Dubilier (ESRD)	(508) 996-8561	(508) 996-3830	www.cornell-dubilier.com
	Sanyo (POSCAP)	(619) 661-6322	(619) 661-1055	www.sanyovideo.com

Maximum Load Under Start-Up

Due to the LM3354's unique start-up sequence, it is not able to start up under all load conditions. Starting with 60 mA or less will allow the part to start correctly under any temperature or input voltage conditions. After the output is in regulation, any load up to the maximum as specified in the Electrical Characteristics may be applied. Using a Power On Reset circuit, such as the LP3470, is recommended if greater start up loads are expected. Under certain conditions the LM3354 can start up with greater load currents without the use of a Power On Reset Circuit.

Thermal Protection

During output short circuit conditions, the LM3354 will draw high currents causing a rise in the junction temperature. On-chip thermal protection circuitry disables the charge pump action once the junction temperature exceeds the thermal trip point, and re-enables the charge pump when the junction temperature falls back to a safe operating point.

Typical Application Circuits

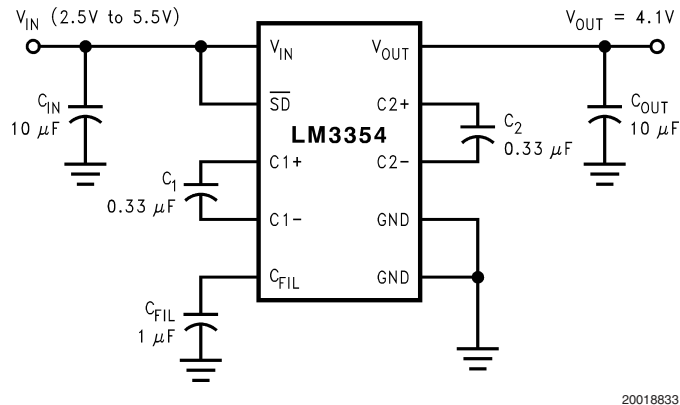

FIGURE 2. Basic Buck/Boost Regulator

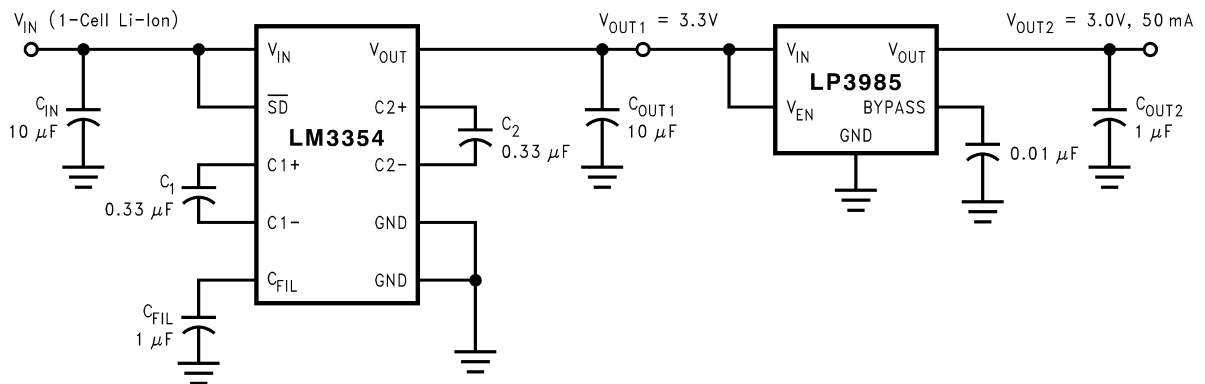
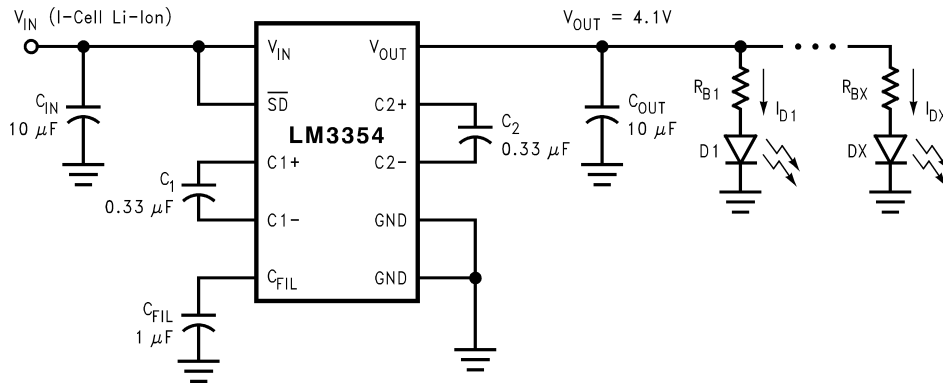

FIGURE 3. Low Output Noise and Ripple Buck/Boost Regulator

Typical Application Circuits (Continued)



20018840

FIGURE 4. White LED Driver

Driving Light Emitting Diodes

The LM3354 can be used to drive LED's of nearly any color. The 4.1V option is ideal for driving the White LED's required for the backlight of small color displays. Figure 4 shows the circuit used to power White LED's. The LED current is set by the resistors R_B by using the equation $I_{LED} = (4.1V - V_F)/R_B$ where V_F is the typical forward voltage drop of the LED used.

The brightness of the diodes may be controlled using the shutdown pin. A PWM signal on the shutdown pin may be used to adjust the brightness by varying the duty cycle. A signal between 60Hz and 200Hz may be used for best linearity. In this case the equivalent LED current is approxi-

mately equal to the maximum current multiplied by the duty cycle. Using frequencies above 200Hz may cause less linear results as the charge and discharge time of the output capacitor becomes more significant.

Layout Considerations

Due to the 1 MHz typical switching frequency of the LM3354, careful board layout is a must. It is important to place the capacitors as close to the IC as possible and to keep the traces between the capacitors and the IC short and direct. Use of a ground plane is recommended. Figure 5 shows a typical layout as used in the LM3354 evaluation board.

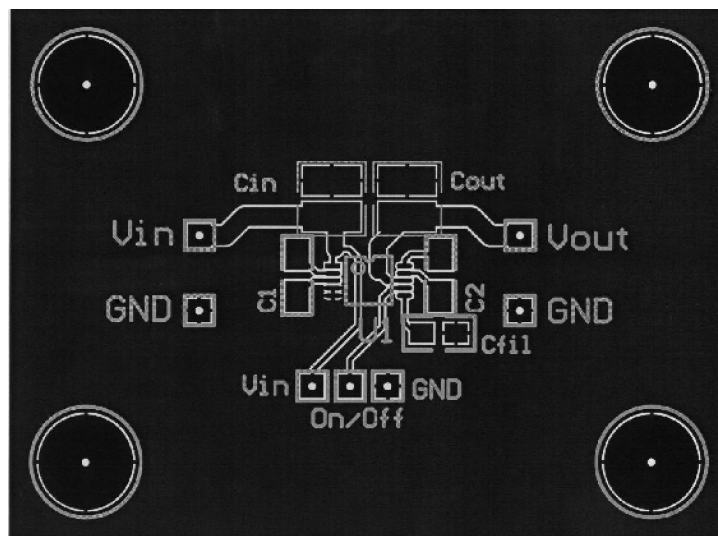

20018816

FIGURE 5. Typical Layout, Top View (magnification 1.5X)

Physical Dimensions inches (millimeters) unless otherwise noted

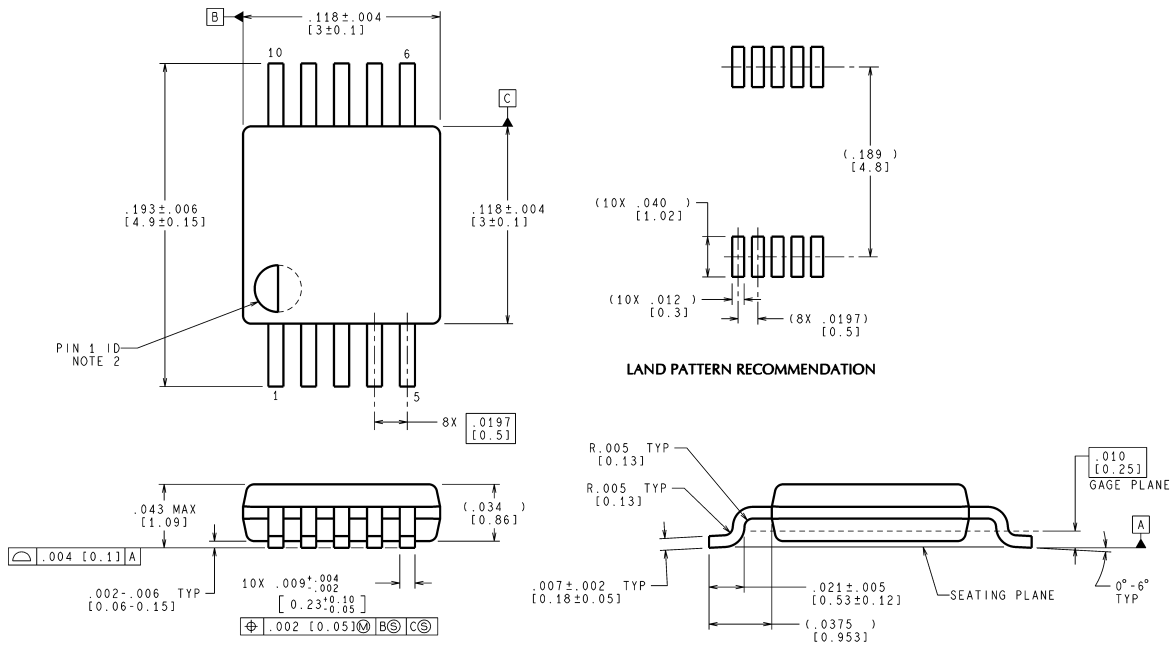

CONTROLLING DIMENSION IS INCH
VALUES IN [] ARE MILLIMETERS
DIMENSIONS IN () FOR REFERENCE ONLY

MUB10A (Rev B)

MSOP-10 Pin Package (MM)
For Ordering, Refer to Ordering Information Table
NS Package Number MUB10A

National does not assume any responsibility for use of any circuitry described, no circuit patent licenses are implied and National reserves the right at any time without notice to change said circuitry and specifications.

For the most current product information visit us at www.national.com.

LIFE SUPPORT POLICY

NATIONAL'S PRODUCTS ARE NOT AUTHORIZED FOR USE AS CRITICAL COMPONENTS IN LIFE SUPPORT DEVICES OR SYSTEMS WITHOUT THE EXPRESS WRITTEN APPROVAL OF THE PRESIDENT AND GENERAL COUNSEL OF NATIONAL SEMICONDUCTOR CORPORATION. As used herein:

1. Life support devices or systems are devices or systems which, (a) are intended for surgical implant into the body, or (b) support or sustain life, and whose failure to perform when properly used in accordance with instructions for use provided in the labeling, can be reasonably expected to result in a significant injury to the user.
2. A critical component is any component of a life support device or system whose failure to perform can be reasonably expected to cause the failure of the life support device or system, or to affect its safety or effectiveness.

BANNED SUBSTANCE COMPLIANCE

National Semiconductor certifies that the products and packing materials meet the provisions of the Customer Products Stewardship Specification (CSP-9-111C2) and the Banned Substances and Materials of Interest Specification (CSP-9-111S2) and contain no "Banned Substances" as defined in CSP-9-111S2.



National Semiconductor
Americas Customer
Support Center
Email: new.feedback@nsc.com
Tel: 1-800-272-9959

National Semiconductor
Europe Customer Support Center
Fax: +49 (0) 180-530 85 86
Email: europa.support@nsc.com
Deutsch Tel: +49 (0) 69 9508 6208
English Tel: +44 (0) 870 24 0 2171
Français Tel: +33 (0) 1 41 91 8790

National Semiconductor
Asia Pacific Customer
Support Center
Email: ap.support@nsc.com

National Semiconductor
Japan Customer Support Center
Fax: 81-3-5639-7507
Email: jpn.feedback@nsc.com
Tel: 81-3-5639-7560

www.national.com