

Features

- Small package dimensions
- RoHS compliant*
- Power rating at 70 °C = 1/16 W
- Tight dimensional tolerances
- Three layer termination process with nickel barrier prevents leaching and provides excellent solderability
- Suitable for most types of soldering processes
- Standard packaging on paper tape and reel

CR0402 - Chip Resistor

Electrical Characteristics

Power Rating @ 70 °C 1/16 W
 Operating Temperature Range -55 °C to +155 °C
 Derated to 0 Load at +155 °C
 Maximum Working Voltage 50 V
 Maximum Overload Voltage 100 V
 Resistance Range
 1 %, E-96 and E-24 10 ohms to 1 megohm
 5 %, E-24 2.2 ohms to 5.6 megohms
 Zero Ohm Jumper <0.05 ohms
 Temperature Coefficient
 1 % ±100 ppm/°C
 5 % ±200 ppm/°C
 2.2 ohm to 10 ohms -200 ppm/°C to +500 ppm/°C

Derating Curve

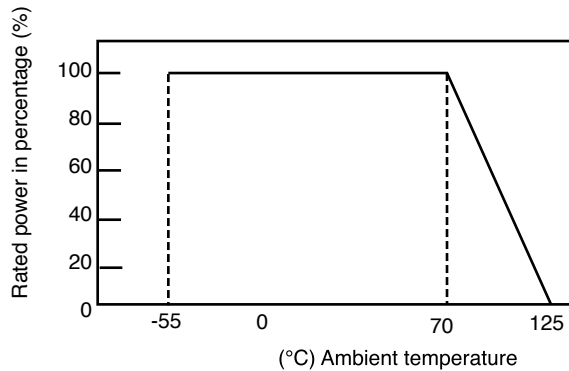

For Standard Values Used in Capacitors, Inductors, and Resistors, [click here](#).

Dimensional Drawings

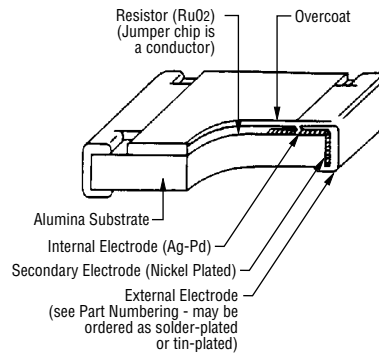
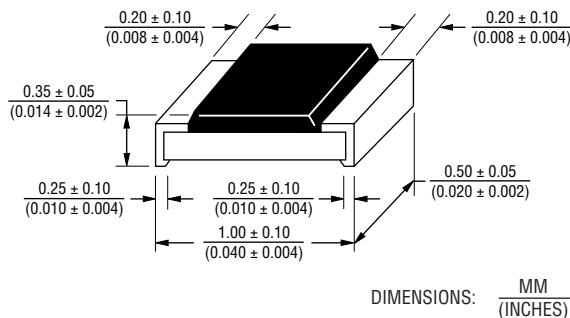

Characteristic Data

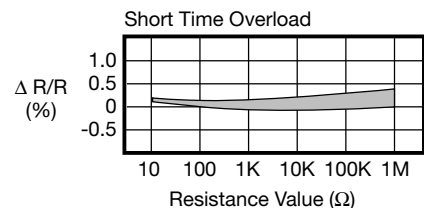
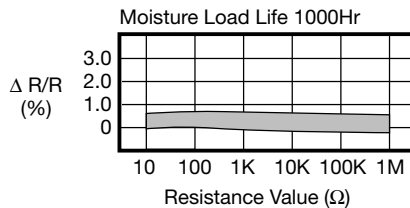
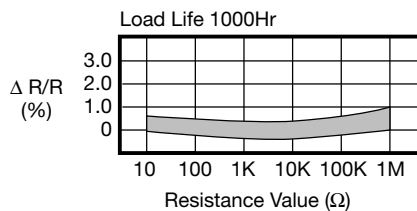

*RoHS Directive 2002/95/EC Jan 27 2003 including Annex. Specifications are subject to change without notice. Customers should verify actual device performance in their specific applications

CR0402 - Chip Resistor

BOURNS®

Soldering Profile for RoHS Compliant Chip Resisors and Arrays

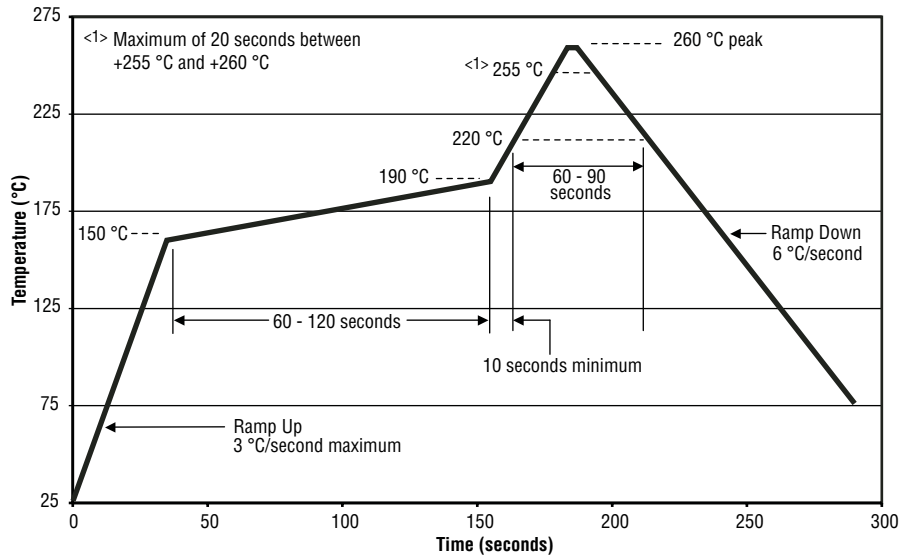

Packaging Dimensions (Conforms to EIA RS-481A)

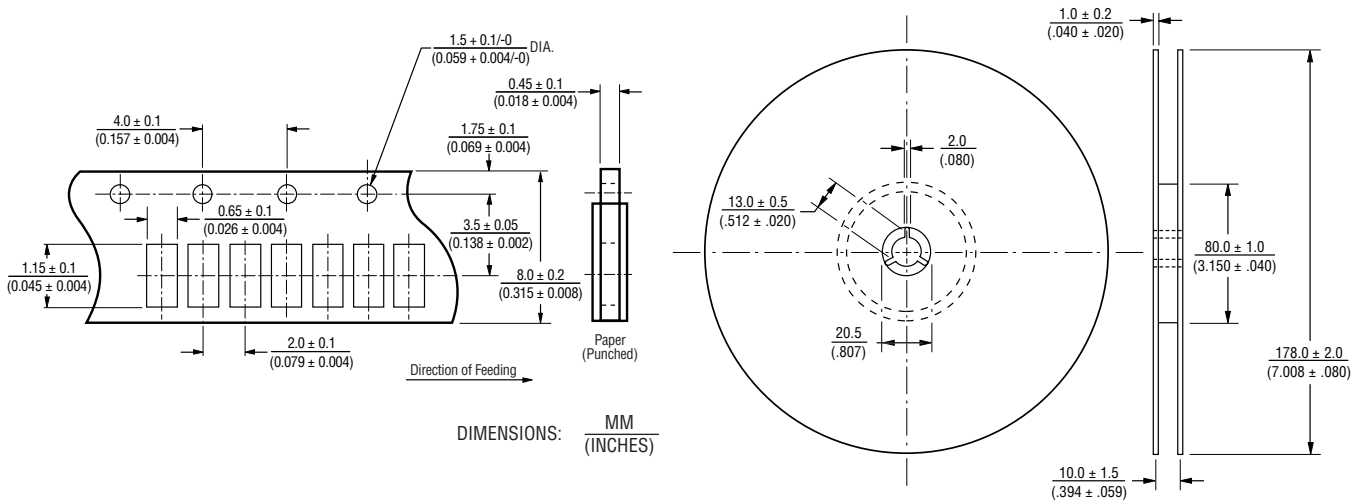

Part Marking System

No Marking on the CR0402 Chip Resistors.

Specifications are subject to change without notice. Customers should verify actual device performance in their specific applications

CR0402 - Chip Resistor

BOURNS®

How to Order

CR 0402 - F X - 8252 G LF

Model _____
(CR = Chip Resistor)

Size _____
• 0402

Resistance Tolerance _____
F = $\pm 1\%$ Used with "X" TCR code only for values from 10 ohms through 1 megohm.
J = $\pm 5\%$ Used with "W" TCR code for values from 10 ohms through 5.6 megohms. Used with "/" TCR code for zero ohm (jumper) and for values from 1 ohm through 9.1 ohms.

TCR (ppm/ $^{\circ}$ C) _____
X = ± 100 Used with "F" Resistance Tolerance code only for values from 10 ohms through 1 megohm.
W = ± 200 Used with "J" Resistance Tolerance code only for values from 10 ohms through 5.6 megohms.
/ = -250 to +500 ...Used with "J" Resistance Tolerance code only for zero ohm (jumper), and for values from 1 ohm through 9.1ohms.

Resistance Value _____
For 1 % Tolerance:
<100 ohms "R" designates decimal point (example: 24R3 = 24.3 ohms)
 ≥ 100 ohmsFirst three digits are significant, fourth digit represents number of zeros to follow (example: 8252 = 82.5k ohms).
For 5 % Tolerance:
<10 ohms "R" designates decimal point (example: 4R7 = 4.7 ohms)
 ≥ 10 ohmsFirst two digits are significant, third digit represents number of zeros to follow (example: 474 = 470k ohms; 000 = Jumper).

Packaging _____
G = Paper Tape (10,000 pcs.) on 7 " Plastic Reel

Termination _____
LF = Tin-plated (RoHS compliant)

REV. 08/08

Specifications are subject to change without notice.
Customers should verify actual device performance in their specific applications