

Portable Internet Audio CODEC with Headphone Driver and Programmable Sample Rates

DESCRIPTION

The WM8731 or WM8731L (WM8731/L) are low power stereo CODECs with an integrated headphone driver. The WM8731/L is designed specifically for portable MP3 audio and speech players and recorders. The WM8731 is also ideal for MD, CD-RW machines and DAT recorders.

Stereo line and mono microphone level audio inputs are provided, along with a mute function, programmable line level volume control and a bias voltage output suitable for an electret type microphone.

Stereo 24-bit multi-bit sigma delta ADCs and DACs are used with oversampling digital interpolation and decimation filters. Digital audio input word lengths from 16-32 bits and sampling rates from 8kHz to 96kHz are supported.

Stereo audio outputs are buffered for driving headphones from a programmable volume control, line level outputs are also provided along with anti-thump mute and power up/down circuitry.

The device is controlled via a 2 or 3 wire serial interface. The interface provides access to all features including volume controls, mutes, de-emphasis and extensive power management facilities. The device is available in a small 28-lead SSOP package or the smaller 28 lead quad flat leadless package (QFN).

FEATURES

- Highly Efficient Headphone Driver
- Audio Performance
 - ADC SNR 90dB ('A' weighted) at 3.3V, 85dB at 1.8V
 - DAC SNR 100dB ('A' weighted) at 3.3V, 95dB at 1.8V
- Low Power
 - Playback only 22mW, 8mW ('L' Variant)
 - Analogue Pass Through 12mW, 3.5mW ('L' variant)
 - 1.42 – 3.6V Digital Supply Operation
 - 2.7 – 3.6V Analogue Supply Operation
 - 1.8 – 3.6V Analogue Supply Operation ('L' Variant)
- ADC and DAC Sampling Frequency: 8kHz – 96kHz
- Selectable ADC High Pass Filter
- 2 or 3-Wire MPU Serial Control Interface
- Programmable Audio Data Interface Modes
 - I²S, Left, Right Justified or DSP
 - 16/20/24/32 bit Word Lengths
 - Master or Slave Clocking Mode
- Microphone Input and Electret Bias with Side Tone Mixer
- Available in 28-lead SSOP or 28-lead QFN package

APPLICATIONS

- Portable MP3 Players and Recorders
- CD and Minidisc Recorders
- PDAs / smartphones

BLOCK DIAGRAM

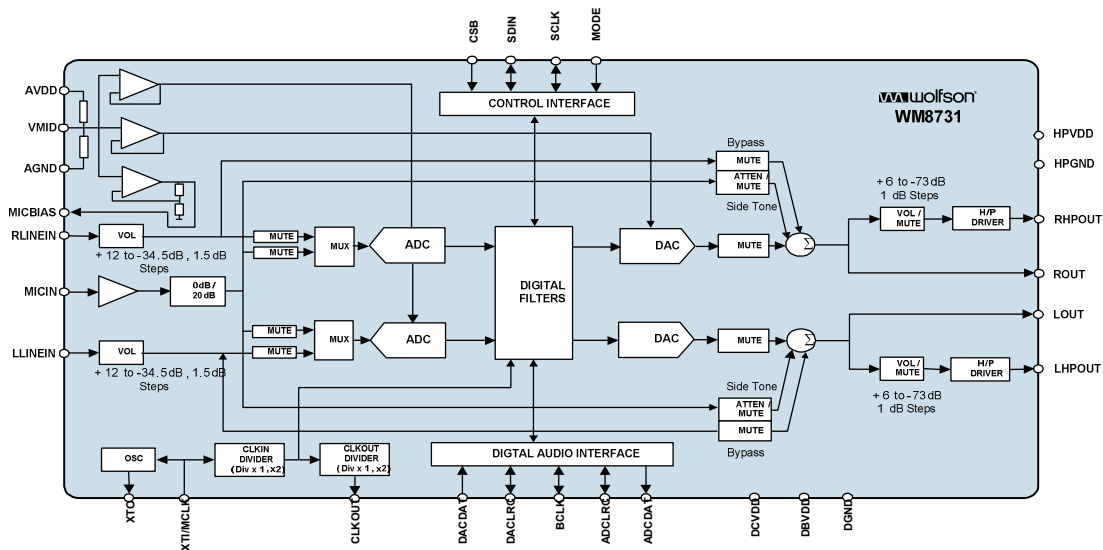

TABLE OF CONTENTS

DESCRIPTION	1
FEATURES	1
APPLICATIONS	1
BLOCK DIAGRAM	1
PIN CONFIGURATION - 28 PIN SSOP	3
ORDERING INFORMATION	3
PIN CONFIGURATION – 28 PIN QFN	4
ORDERING INFORMATION	4
PIN DESCRIPTION	5
ABSOLUTE MAXIMUM RATINGS	6
RECOMMENDED OPERATING CONDITIONS – WM8731	6
RECOMMENDED OPERATING CONDITIONS – WM8731L	6
ELECTRICAL CHARACTERISTICS – WM8731	7
TERMINOLOGY	9
POWER CONSUMPTION – WM8731	10
ELECTRICAL CHARACTERISTICS – WM8731L	11
TERMINOLOGY	13
POWER CONSUMPTION – WM8731L	14
MASTER CLOCK TIMING	15
DIGITAL AUDIO INTERFACE – MASTER MODE	16
DIGITAL AUDIO INTERFACE – SLAVE MODE	17
MPU INTERFACE TIMING	18
DEVICE DESCRIPTION	20
INTRODUCTION	20
AUDIO SIGNAL PATH.....	21
DEVICE OPERATION	34
AUDIO DATA SAMPLING RATES.....	41
ACTIVATING DSP AND DIGITAL AUDIO INTERFACE	45
SOFTWARE CONTROL INTERFACE.....	45
POWER DOWN MODES	47
REGISTER MAP	49
DIGITAL FILTER CHARACTERISTICS	54
TERMINOLOGY	55
DAC FILTER RESPONSES	56
ADC FILTER RESPONSES	57
ADC HIGH PASS FILTER	58
DIGITAL DE-EMPHASIS CHARACTERISTICS	58
DIGITAL DE-EMPHASIS CHARACTERISTICS	59
APPLICATIONS INFORMATION	60
RECOMMENDED EXTERNAL COMPONENTS	60
MINIMISING POP NOISE AT THE ANALOGUE OUTPUTS.....	61
PACKAGE DIMENSIONS - SSOP	62
PACKAGE DIMENSIONS - QFN	63
IMPORTANT NOTICE	64
ADDRESS:	64

PIN CONFIGURATION - 28 PIN SSOP

DBVDD	<input type="checkbox"/>	1 ●	28	<input type="checkbox"/>	DGND
CLKOUT	<input type="checkbox"/>	2	27	<input type="checkbox"/>	DCVDD
BCLK	<input type="checkbox"/>	3	26	<input type="checkbox"/>	XTO
DACDAT	<input type="checkbox"/>	4	25	<input type="checkbox"/>	XTI/MCLK
DACLR	<input type="checkbox"/>	5	24	<input type="checkbox"/>	SCLK
ADCDAT	<input type="checkbox"/>	6	23	<input type="checkbox"/>	SDIN
ADCLR	<input type="checkbox"/>	7	22	<input type="checkbox"/>	CSB
HPVDD	<input type="checkbox"/>	8	21	<input type="checkbox"/>	MODE
LHPOUT	<input type="checkbox"/>	9	20	<input type="checkbox"/>	LLINEIN
RHPOUT	<input type="checkbox"/>	10	19	<input type="checkbox"/>	RLINEIN
HPGND	<input type="checkbox"/>	11	18	<input type="checkbox"/>	MICIN
LOUT	<input type="checkbox"/>	12	17	<input type="checkbox"/>	MICBIAS
ROUT	<input type="checkbox"/>	13	16	<input type="checkbox"/>	VMID
AVDD	<input type="checkbox"/>	14	15	<input type="checkbox"/>	AGND

ORDERING INFORMATION

DEVICE	TEMPERATURE RANGE	AVDD RANGE	PACKAGE	MOISTURE SENSITIVITY LEVEL	PEAK SOLDERING TEMPERATURE
WM8731SEDS/V	-40 to +85°C	2.7 to 3.6V	28-lead SSOP (Pb-free)	MSL3	260°C
WM8731SEDS/RV	-40 to +85°C	2.7 to 3.6V	28-lead SSOP (Pb-free, tape and reel)	MSL3	260°C

Note:

Reel quantity = 2,000

PIN CONFIGURATION – 28 PIN QFN

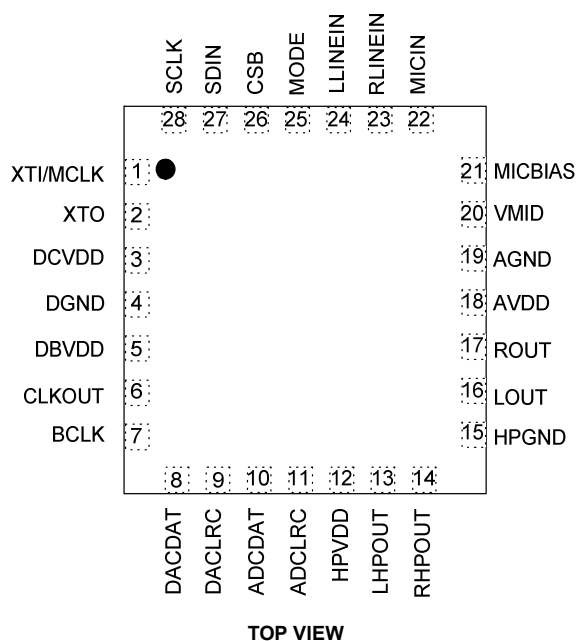

ORDERING INFORMATION

DEVICE	TEMPERATURE RANGE	AVDD RANGE	PACKAGE	MOISTURE SENSITIVITY LEVEL	PEAK SOLDERING TEMPERATURE
WM8731LSEFL	-40 to +85°C	1.8 to 3.6V	28-lead QFN (Pb-free)	MSL1	260°C
WM8731LSEFL/R	-40 to +85°C	1.8 to 3.6V	28-lead QFN (Pb-free, tape and reel)	MSL1	260°C
WM8731SEFL	-40 to +85°C	2.7 to 3.6V	28-lead QFN (Pb-free)	MSL1	260°C
WM8731SEFL/R	-40 to +85°C	2.7 to 3.6V	28-lead QFN (Pb-free, tape and reel)	MSL1	260°C

Note:

Reel quantity = 3,500

PIN DESCRIPTION

28 PIN SSOP	28 PIN QFN	NAME	TYPE	DESCRIPTION
1	5	DBVDD	Supply	Digital Buffers VDD
2	6	CLKOUT	Digital Output	Buffered Clock Output
3	7	BCLK	Digital Input/Output	Digital Audio Bit Clock, Pull Down, (see Note 1)
4	8	DACDAT	Digital Input	DAC Digital Audio Data Input
5	9	DACLRC	Digital Input/Output	DAC Sample Rate Left/Right Clock, Pull Down (see Note 1)
6	10	ADCDAT	Digital Output	ADC Digital Audio Data Output
7	11	ADCLRC	Digital Input/Output	ADC Sample Rate Left/Right Clock, Pull Down (see Note 1)
8	12	HPVDD	Supply	Headphone VDD
9	13	LHPOUT	Analogue Output	Left Channel Headphone Output
10	14	RHPOUT	Analogue Output	Right Channel Headphone Output
11	15	HPGND	Ground	Headphone GND
12	16	LOUT	Analogue Output	Left Channel Line Output
13	17	ROUT	Analogue Output	Right Channel Line Output
14	18	AVDD	Supply	Analogue VDD
15	19	AGND	Ground	Analogue GND
16	20	VMID	Analogue Output	Mid-rail reference decoupling point
17	21	MICBIAS	Analogue Output	Electret Microphone Bias
18	22	MICIN	Analogue Input	Microphone Input (AC coupled)
19	23	RLINEIN	Analogue Input	Right Channel Line Input (AC coupled)
20	24	LLINEIN	Analogue Input	Left Channel Line Input (AC coupled)
21	25	MODE	Digital Input	Control Interface Selection, Pull Up (see Note 1)
22	26	CSB	Digital Input	3-Wire MPU Chip Select/ 2-Wire MPU interface address selection, active low, Pull up (see Note 1)
23	27	SDIN	Digital Input/Output	3-Wire MPU Data Input / 2-Wire MPU Data Input
24	28	SCLK	Digital Input	3-Wire MPU Clock Input / 2-Wire MPU Clock Input
25	1	XTI/MCLK	Digital Input	Crystal Input or Master Clock Input (MCLK)
26	2	XTO	Digital Output	Crystal Output
27	3	DCVDD	Supply	Digital Core VDD
28	4	DGND	Ground	Digital GND

Note:

1. Pull Up/Down only present when Control Register Interface ACTIVE=0 to conserve power.
2. It is recommended that the QFN ground paddle is connected to analogue ground on the application PCB.

ABSOLUTE MAXIMUM RATINGS

Absolute Maximum Ratings are stress ratings only. Permanent damage to the device may be caused by continuously operating at or beyond these limits. Device functional operating limits and guaranteed performance specifications are given under Electrical Characteristics at the test conditions specified.



ESD Sensitive Device. This device is manufactured on a CMOS process. It is therefore generically susceptible to damage from excessive static voltages. Proper ESD precautions must be taken during handling and storage of this device.

Wolfson tests its package types according to IPC/JEDEC J-STD-020B for Moisture Sensitivity to determine acceptable storage conditions prior to surface mount assembly. These levels are:

MSL1 = unlimited floor life at <30°C / 85% Relative Humidity. Not normally stored in moisture barrier bag.

MSL2 = out of bag storage for 1 year at <30°C / 60% Relative Humidity. Supplied in moisture barrier bag.

MSL3 = out of bag storage for 168 hours at <30°C / 60% Relative Humidity. Supplied in moisture barrier bag.

CONDITION	MIN	MAX
Digital supply voltage	-0.3V	+3.63V
Analogue supply voltage	-0.3V	+3.63V
Voltage range digital inputs	DGND -0.3V	DVDD +0.3V
Voltage range analogue inputs	AGND -0.3V	AVDD +0.3V
Operating temperature range, T _A	-40°C	+85°C
Storage temperature after soldering	-65°C	+150°C

Notes:

- Analogue and digital grounds must always be within 0.3V of each other.
- The digital supply core voltage (DCVDD) must always be less than or equal to the analogue supply voltage (AVDD)

RECOMMENDED OPERATING CONDITIONS – WM8731

PARAMETER	SYMBOL	TEST CONDITIONS	MIN	TYP	MAX	UNIT
Digital supply range (Core)	DCVDD		1.42		3.6	V
Digital supply range (Buffer)	DBVDD		2.7		3.6	V
Analogue supply range	AVDD, HPVDD		2.7		3.6	V
Ground	DGND,AGND,HPGND			0		V

Notes:

- DCVDD must be lower than or equal to DBVDD.
- USB Mode should not be used with DCVDD lower than 2V

RECOMMENDED OPERATING CONDITIONS – WM8731L

PARAMETER	SYMBOL	TEST CONDITIONS	MIN	TYP	MAX	UNIT
Digital supply range (Core)	DCVDD		1.42		3.6	V
Digital supply range (Buffer)	DBVDD		1.8		3.6	V
Analogue supply range	AVDD, HPVDD		1.8		3.6	V
Ground	DGND,AGND,HPGND			0		V

Notes:

- If DBVDD is lower than 2.5V, DCVDD must be at least 0.225V lower than DBVDD.
- If DBVDD is higher than or equal to 2.5V, DCVDD must be lower than or equal to DBVDD.
- USB Mode should not be used with DCVDD lower than 2V

ELECTRICAL CHARACTERISTICS – WM8731

Test Conditions

AVDD, HPVDD, DBVDD = 3.3V, AGND = 0V, DCVDD = 1.5V, DGND = 0V, T_A = +25°C, Slave Mode, fs = 48kHz, XTI/MCLK = 256fs unless otherwise stated.

PARAMETER	SYMBOL	TEST CONDITIONS	MIN	TYP	MAX	UNIT
Digital Logic Levels (CMOS Levels)						
Input LOW level	V _{IL}				0.3 x DBVDD	V
Input HIGH level	V _{IH}		0.7 x DBVDD			V
Output LOW	V _{OL}				0.10 x DBVDD	V
Output HIGH	V _{OH}		0.9 x DBVDD			V
Power On Reset Threshold (DCVDD)						
DCVDD Threshold On -> Off	V _{th}			0.9		V
Hysteresis	V _{IH}			0.3		V
DCVDD Threshold Off -> On	V _{OL}			0.6		V
Analogue Reference Levels						
Reference voltage (VMID)	V _{VMID}			AVDD/2		V
Potential divider resistance	R _{VMID}			50k		Ω
Line Input to ADC						
Input Signal Level (0dB)	V _{INLINE}			1.0 AVDD/3.3		V _{rms}
Signal to Noise Ratio (Note 1,3)	SNR	A-weighted, 0dB gain @ fs = 48kHz	85	90		dB
		A-weighted, 0dB gain @ fs = 96kHz		90		
		A-weighted, 0dB gain @ fs = 48kHz, AVDD = 2.7V		88		
Dynamic Range (Note 3)	DR	A-weighted, -60dB full scale input	85	90		dB
Total Harmonic Distortion	THD	-1dB input, 0dB gain		-84 0.006	-74 0.02	dB %
Power Supply Rejection Ratio	PSRR	1kHz, 100mVpp		50		dB
		20Hz to 20kHz, 100mVpp		45		
ADC channel separation		1kHz input		90		dB
Programmable Gain		1kHz input R _{source} < 50Ω	-34.5	0	+12	dB
Programmable Gain Step Size		Guaranteed Monotonic		1.5		dB
Mute attenuation		0dB, 1kHz input		80		dB
Input Resistance	R _{INLINE}	0dB gain	20k	30k		Ω
		12dB gain	10k	15k		
Input Capacitance	C _{INLINE}			10		pF

Test Conditions

AVDD, HPVDD, DBVDD = 3.3V, AGND = 0V, DCVDD = 1.5V, DGND = 0V, T_A = +25°C, Slave Mode, fs = 48kHz, XTI/MCLK = 256fs unless otherwise stated.

Microphone Input to ADC @ 0dB Gain, fs = 48kHz (40kΩ Source Impedance. See Figure 12)						
Input Signal Level (0dB)	V _{INMIC}			1.0 AVDD/3.3		V _{rms}
Signal to Noise Ratio (Note 1,3)	SNR	A-weighted, 0dB gain	85			dB
Dynamic Range (Note 3)	DR	A-weighted, -60dB full scale input	85			dB
Total Harmonic Distortion	THD	0dB input, 0dB gain	-60	-55		dB
Power Supply Rejection Ratio	PSRR	1kHz 100mVpp	50			dB
		20Hz to 20kHz 100mVpp	45			dB
Programmable Gain Boost	MICBOOST bit set	1kHz input R _{source} < 50Ω	34			dB
Mic Path gain (MICBOOST gain is additional to this nominal gain)		MICBOOST = 0 R _{source} < 50Ω	14			dB
Mute attenuation		0dB, 1kHz input	80			dB
Input Resistance	R _{INMIC}		10k			Ω
Input Capacitance	C _{INMIC}		10			pF
Microphone Bias						
Bias Voltage	V _{MICBIAS}		0.75*AVDD - 100mV	0.75*AVDD	0.75*AVDD + 100mV	V
Bias Current Source	I _{MICBIAS}				3	mA
Output Noise Voltage	V _n	1K to 20kHz		25		nV/√Hz
Line Output for DAC Playback Only (Load = 10kΩ, 50pF)						
0dBfs Full scale output voltage		At LINE outputs		1.0 x AVDD/3.3		V _{rms}
Signal to Noise Ratio (Note 1,3)	SNR	A-weighted, @ fs = 48kHz	95	100		dB
		A-weighted @ fs = 96kHz		98		
		A-weighted, fs = 48kHz, AVDD = 2.7V		98		
Dynamic Range (Note 3)	DR	A-weighted, -60dB full scale input	85	95		dB
Total Harmonic Distortion	THD	1kHz, 0dBfs		-88	-80	dB
		1kHz, -3dBfs		-92		
Power Supply Rejection Ratio	PSRR	1kHz 100mVpp		50		dB
		20Hz to 20kHz 100mVpp		45		
DAC channel separation	1kHz, 0dB			100		dB
Analogue Line Input to Line Output (Load = 10kΩ, 50pF, No Gain on Input) Bypass Mode						
0dB Full scale output voltage				1.0 x AVDD/3.3		V _{rms}
Signal to Noise Ratio (Note 1,3)	SNR		90	95		dB
Total Harmonic Distortion	THD	1kHz, 0dB		-86	-80	dB
		1kHz, -3dB		-92		
Power Supply Rejection Ratio	PSSR	1kHz 100mVpp		50		dB
		20Hz to 20kHz 100mVpp		45		
Mute attenuation		1kHz, 0dB		80		dB

Test Conditions

AVDD, HPVDD, DBVDD = 3.3V, AGND = 0V, DCVDD = 1.5V, DGND = 0V, T_A = +25°C, Slave Mode, fs = 48kHz, XTI/MCLK = 256fs unless otherwise stated.

Stereo Headphone Output						
0dB Full scale output voltage				1.0 x AVDD/3.3		Vrms
Max Output Power	P _O	RL = 32Ω		30		mW
		RL = 16Ω		50		
Signal to Noise Ratio (Note 1, 3)	SNR	A-weighted	90	97		dB
Total Harmonic Distortion	THD	1kHz, R _L = 32Ω P _O = 10mW rms (-5dB)		0.056 -65	0.1 60	% dB
		1kHz, R _L = 32Ω P _O = 20mW rms (-2dB)		0.56 -45	1.0 40	% dB
Power Supply Rejection Ratio	PSRR	1kHz 100mVpp		50		dB
		20Hz - 20kHz, 100mVpp		45		
Programmable Gain		1kHz	-73	0	6	dB
Programmable Gain Step Size		1kHz		1		dB
Mute attenuation		1kHz, 0dB		80		dB
Microphone Input to Headphone Output Side Tone Mode						
0dB Full scale output voltage				1.0 x AVDD/3.3		Vrms
Signal to Noise Ratio (Note 1,3)	SNR		90	95		dB
Power Supply Rejection Ratio	PSRR	1kHz 100mVpp		50		dB
		20Hz to 20kHz 100mVpp		45		
Programmable Attenuation		1kHz	6		15	dB
Programmable Attenuation Step Size		1kHz		3		dB
Mute attenuation		1kHz, 0dB		80		dB

Notes:

- Ratio of output level with 1kHz full scale input, to the output level with the input short circuited, measured 'A' weighted over a 20Hz to 20kHz bandwidth using an Audio analyser.
- Ratio of output level with 1kHz full scale input, to the output level with all zeros into the digital input, measured 'A' weighted over a 20Hz to 20kHz bandwidth.
- All performance measurements done with 20kHz low pass filter, and where noted an A-weight filter. Failure to use such a filter will result in higher THD+N and lower SNR and Dynamic Range readings than are found in the Electrical Characteristics. The low pass filter removes out of band noise; although it is not audible it may affect dynamic specification values.
- VMD decoupled with 10uF and 0.1uF capacitors (smaller values may result in reduced performance).

TERMINOLOGY

- Signal-to-noise ratio (dB) - SNR is a measure of the difference in level between the full scale output and the output with no signal applied. (No Auto-zero or Automute function is employed in achieving these results).
- Dynamic range (dB) - DR is a measure of the difference between the highest and lowest portions of a signal. Normally a THD+N measurement at 60dB below full scale. The measured signal is then corrected by adding the 60dB to it. (e.g. THD+N @ -60dB = -32dB, DR = 92dB).
- THD+N (dB) - THD+N is a ratio, of the rms values, of (Noise + Distortion)/Signal.
- Channel Separation (dB) - Also known as Cross-Talk. This is a measure of the amount one channel is isolated from the other. Normally measured by sending a full scale signal down one channel and measuring the other.

POWER CONSUMPTION – WM8731

MODE DESCRIPTION	POWEROFF	CLKOUTPD	OSCPD	OUTPD	DACPD	ADCPD	MICPD	LINEINPD	CURRENT CONSUMPTION TYPICAL				
									AVDD (3.3V)	HP VDD (3.3V)	DC VDD (1.5V)	DB VDD (3.3V)	UNIT
Record and Playback													
Oscillator enabled	0	0	0	0	0	0	0	0	13.1	1.7	3.0	1.5	mA
External MCLK	0	0	1	0	0	0	0	0	13.1	1.7	3.2	0.8	mA
Oscillator and CLKOUT disabled, No microphone	0	1	1	0	0	0	1	0	12.2	1.7	3.2	0.07	mA
Playback Only													
Oscillator enabled	0	0	0	0	0	1	1	1	3.4	1.7	2.1	1.5	mA
External MCLK	0	1	1	0	0	1	1	1	3.3	1.7	2.3	0.07	mA
Record Only													
Line Record, oscillator enabled	0	0	0	1	1	0	1	0	9.2	-	2.6	1.3	mA
Line Record, using external MCLK	0	0	1	1	1	0	1	0	9.2	-	2.6	0.7	mA
Mic Record, oscillator enabled	0	0	0	1	1	0	0	1	8.6	-	2.7	1.5	mA
Mic Record, using external MCLK	0	0	1	1	1	0	0	1	8.6	-	2.6	0.7	mA
Side Tone (Microphone Input to Headphone Output)													
External clock still running	0	0	1	0	1	1	0	1	1.6	1.7	0.08	0.7	mA
Clock stopped	0	0	1	0	1	1	0	1	1.5	1.7	-	-	mA
Analogue Bypass (Line-in to Line-out)													
External clock still running	0	0	1	0	1	1	1	0	2.1	1.7	0.08	0.7	mA
Clock stopped	0	0	1	0	1	1	1	0	2.2	1.7	-	-	mA
Standby													
External clock still running	0	1	1	1	1	1	1	1	16	0.3	77	65	μA
Clock stopped	0	1	1	1	1	1	1	1	16	0.3	0.3	0.2	μA
Power Down													
External clock still running	1	1	1	1	1	1	1	1	0.2	0.3	77	65	μA
Clock stopped	1	1	1	1	1	1	1	1	0.3	0.3	0.3	0.3	μA

Table 1 Powerdown Mode Current Consumption Examples

Notes:

1. $T_A = +25^\circ\text{C}$. $f_s = 48\text{kHz}$, $\text{XTI/MCLK} = 256\text{fs}$ (12.288MHz).
2. The data presented here was measured with the audio interface in master mode whenever the internal clock oscillator was used, and in slave mode whenever an external clock was used (i.e. $\text{MS} = 1$ when $\text{OSCPD} = 0$ and vice versa). However, it is also possible to use the WM8731 with $\text{MS} = \text{OSCPD} = 0$ or $\text{MS} = \text{OSCPD} = 1$.
3. All figures are quiescent, with no signal.
4. The power dissipation in the headphone itself not included in the above table.

ELECTRICAL CHARACTERISTICS – WM8731L

Test Conditions

AVDD, HPVDD, DBVDD = 1.8V, AGND = 0V, DCVDD = 1.5V, DGND = 0V, T_A = +25°C, Slave Mode, fs = 48kHz, XTI/MCLK = 256fs unless otherwise stated.

PARAMETER	SYMBOL	TEST CONDITIONS	MIN	TYP	MAX	UNIT
Digital Logic Levels (CMOS Levels)						
Input LOW level	V _{IL}				0.3 x DBVDD	V
Input HIGH level	V _{IH}		0.7 x DBVDD			V
Output LOW	V _{OL}				0.10 x DBVDD	V
Output HIGH	V _{OH}		0.9 x DBVDD			V
Power On Reset Threshold (DCVDD)						
DCVDD Threshold On -> Off	V _{th}			0.9		V
Hysteresis	V _{IH}			0.3		V
DCVDD Threshold Off -> On	V _{OL}			0.6		V
Analogue Reference Levels						
Reference voltage (VMID)	V _{VMID}			AVDD/2		V
Potential divider resistance	R _{VMID}			50k		Ω
Line Input to ADC						
Input Signal Level (0dB)	V _{INLINE}			1.0 AVDD/3.3		V _{rms}
Signal to Noise Ratio (Note 1,3)	SNR	A-weighted, 0dB gain @ fs = 48kHz	75	85		dB
		A-weighted, 0dB gain @ fs = 96kHz		85		
Dynamic Range (Note 3)	DR	A-weighted, -60dB full scale input	80	88		dB
Total Harmonic Distortion	THD	-1dB input, 0dB gain		-76	-60	dB
Power Supply Rejection Ratio	PSRR	1kHz, 100mVpp		50		dB
		20Hz to 20kHz, 100mVpp		45		
ADC channel separation		1kHz input		90		dB
Programmable Gain		1kHz input R _{source} < 50Ω	-34.5	0	+12	dB
Programmable Gain Step Size		Guaranteed Monotonic		1.5		dB
Mute attenuation		0dB, 1kHz input		80		dB
Input Resistance	R _{INLINE}	0dB gain	20k	30k		Ω
		12dB gain	10k	15k		
Input Capacitance	C _{INLINE}			10		pF

Test Conditions

AVDD, HPVDD, DBVDD = 1.8V, AGND = 0V, DCVDD = 1.5V, DGND = 0V, T_A = +25°C, Slave Mode, fs = 48kHz, XTI/MCLK = 256fs unless otherwise stated.

Microphone Input to ADC @ 0dB Gain, fs = 48kHz (40kΩ Source Impedance. See Figure 12)						
Input Signal Level (0dB)	V _{INMIC}			1.0 AVDD/3.3		V _{rms}
Signal to Noise Ratio (Note 1,3)	SNR	A-weighted, 0dB gain	80			dB
Dynamic Range (Note 3)	DR	A-weighted, -60dB full scale input	70			dB
Total Harmonic Distortion	THD	0dB input, 0dB gain	-55			dB
Power Supply Rejection Ratio	PSRR	1kHz 100mVpp	50			dB
		20Hz to 20kHz 100mVpp	45			dB
Programmable Gain Boost	MICBOOST bit set	1kHz input R _{source} < 50Ω	34			dB
Mic Path gain (MICBOOST gain is additional to this nominal gain)		MICBOOST = 0 R _{source} < 50Ω	14			dB
Mute attenuation		0dB, 1kHz input	80			dB
Input Resistance	R _{INMIC}		10k			Ω
Input Capacitance	C _{INMIC}		10			pF
Microphone Bias						
Bias Voltage	V _{MICBIAS}		0.75*AVDD – 100mV	0.75*AVDD	0.75*AVDD + 100mV	V
Bias Current Source	I _{MICBIAS}				3	mA
Output Noise Voltage	V _n	1K to 20kHz		25		nV/√Hz
Line Output for DAC Playback Only (Load = 10k Ω. 50pF)						
0dBfs Full scale output voltage		At LINE outputs		1.0 x AVDD/3.3		V _{rms}
Signal to Noise Ratio (Note 1,3)	SNR	A-weighted, @ fs = 48kHz	85	95		dB
		A-weighted @ fs = 96kHz		93		
Dynamic Range (Note 3)	DR	A-weighted, -60dB full scale input	85	90		dB
Total Harmonic Distortion	THD	1kHz, 0dBfs		-80	-75	dB
		1kHz, -3dBfs		-90		
Power Supply Rejection Ratio	PSRR	1kHz 100mVpp		50		dB
		20Hz to 20kHz 100mVpp		45		
DAC channel separation	1kHz, 0dB			100		dB
Analogue Line Input to Line Output (Load = 10k Ω. 50pF, No Gain on Input) Bypass Mode						
0dB Full scale output voltage				1.0 x AVDD/3.3		V _{rms}
Signal to Noise Ratio (Note 1,3)	SNR		85	90		dB
Total Harmonic Distortion	THD	1kHz, 0dB		-83	-76	dB
		1kHz, -3dB		-92		
Power Supply Rejection Ratio	PSSR	1kHz 100mVpp		50		dB
		20Hz to 20kHz 100mVpp		45		
Mute attenuation		1kHz, 0dB		80		dB

Test Conditions

AVDD, HPVDD, DBVDD = 1.8V, AGND = 0V, DCVDD = 1.5V, DGND = 0V, T_A = +25°C, Slave Mode, fs = 48kHz, XTI/MCLK = 256fs unless otherwise stated.

Stereo Headphone Output						
0dB Full scale output voltage				1.0 x AVDD/3.3		Vrms
Max Output Power	P _O	RL = 32 Ω		9		mW
		RL = 16 Ω		18		
Signal to Noise Ratio (Note 1,3)	SNR	A-weighted	86	95		dB
Total Harmonic Distortion	THD	1kHz, -5dB FS signal R _L = 32Ω		0.08 -62	0.1 -60	% dB
		1kHz, -2dB FS signal R _L = 32Ω			1 -40	
Power Supply Rejection Ratio	PSRR	1kHz 100mVpp		50		dB
		20Hz - 20kHz, 100mVpp		45		
Programmable Gain		1kHz	-73	0	6	dB
Programmable Gain Step Size		1kHz		1		dB
Mute attenuation		1kHz, 0dB		80		dB
Microphone Input to Headphone Output Side Tone Mode						
0dB Full scale output voltage				1.0 x AVDD/3.3		Vrms
Signal to Noise Ratio (Note 1,3)	SNR		85	90		dB
Power Supply Rejection Ratio	PSRR	1kHz 100mVpp		50		dB
		20Hz to 20kHz 100mVpp		45		
Programmable Attenuation		1kHz	6		15	dB
Programmable Attenuation Step Size		1kHz		3		dB
Mute attenuation		1kHz, 0dB		80		dB

Notes:

- Ratio of output level with 1kHz full scale input, to the output level with the input short circuited, measured 'A' weighted over a 20Hz to 20kHz bandwidth using an Audio analyser.
- Ratio of output level with 1kHz full scale input, to the output level with all zeros into the digital input, measured 'A' weighted over a 20Hz to 20kHz bandwidth.
- All performance measurements done with 20kHz low pass filter, and where noted an A-weight filter. Failure to use such a filter will result in higher THD+N and lower SNR and Dynamic Range readings than are found in the Electrical Characteristics. The low pass filter removes out of band noise; although it is not audible it may affect dynamic specification values.
- VMID decoupled with 10uF and 0.1uF capacitors (smaller values may result in reduced performance).

TERMINOLOGY

- Signal-to-noise ratio (dB) - SNR is a measure of the difference in level between the full scale output and the output with no signal applied. (No Auto-zero or Automute function is employed in achieving these results).
- Dynamic range (dB) - DR is a measure of the difference between the highest and lowest portions of a signal. Normally a THD+N measurement at 60dB below full scale. The measured signal is then corrected by adding the 60dB to it. (e.g. THD+N @ -60dB = -32dB, DR = 92dB).
- THD+N (dB) - THD+N is a ratio, of the rms values, of (Noise + Distortion)/Signal.
- Channel Separation (dB) - Also known as Cross-Talk. This is a measure of the amount one channel is isolated from the other. Normally measured by sending a full scale signal down one channel and measuring the other.

POWER CONSUMPTION – WM8731L

MODE DESCRIPTION	POWEROFF	CLKOUTPD	OSCPD	OUTPD	DACPD	ADCPD	MICPD	LINEINPD	CURRENT CONSUMPTION TYPICAL				
									AVDD (1.8V)	HP VDD (1.8V)	DC VDD (1.5V)	DB VDD (1.8V)	UNIT
Record and Playback													
All active, oscillator enabled	0	0	0	0	0	0	0	0	6	0.6	2.7	0.9	mA
Playback Only													
Oscillator enabled	0	0	0	0	0	1	1	1	1.7	0.6	1.8	0.9	mA
Record Only													
Line Record, oscillator enabled	0	0	0	1	1	0	1	0	3.9	-	2.4	0.9	mA
Mic Record, oscillator enabled	0	0	0	1	1	0	0	1	3.6	-	2.4	0.9	mA
Side Tone (Microphone Input to Headphone Output)													
Clock stopped	0	0	1	0	1	1	0	1	0.8	0.6	-	-	mA
Analogue Bypass (Line-in to Line-out)													
Clock stopped	0	0	1	0	1	1	1	0	1.1	0.6	-	-	mA
Standby													
Clock stopped	0	1	1	1	1	1	1	1	8	-	-	-	μA
Power Down													
Clock stopped	1	1	1	1	1	1	1	1	0.2	0.2	0.3	0.2	μA

Table 2 Powerdown Mode Current Consumption Examples

Notes:

1. AVDD, HPVDD, DBVDD = 1.8V, AGND = 0V, DCVDD = 1.5V, DGND = 0V, T_A = +25°C. Slave Mode, fs = 48kHz, XT1/MCLK = 256fs (12.288MHz).
2. All figures are quiescent, with no signal.
3. All figures are measured with the audio interface in master mode (MS = 1).
4. The power dissipation in the headphone itself is not included in the above table.

MASTER CLOCK TIMING

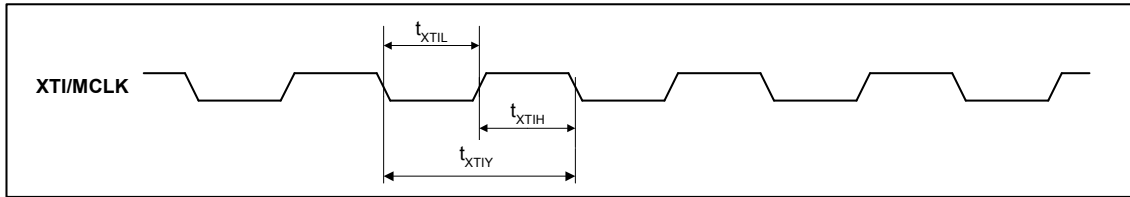

Figure 1 System Clock Timing Requirements

Test Conditions

AVDD, HPVDD, DBVDD = 3.3V, AGND = 0V, DCVDD = 1.5V, DGND = 0V, $T_A = +25^\circ\text{C}$, Slave Mode $f_s = 48\text{kHz}$, XT1/MCLK = 256fs unless otherwise stated.

PARAMETER	SYMBOL	TEST CONDITIONS	MIN	TYP	MAX	UNIT
System Clock Timing Information						
XT1/MCLK System clock pulse width high	t_{XTIH}		18			ns
XT1/MCLK System clock pulse width low	t_{XTIL}		18			ns
XT1/MCLK System clock cycle time	t_{XTIY}		54			ns
XT1/MCLK Duty cycle			40:60		60:40	

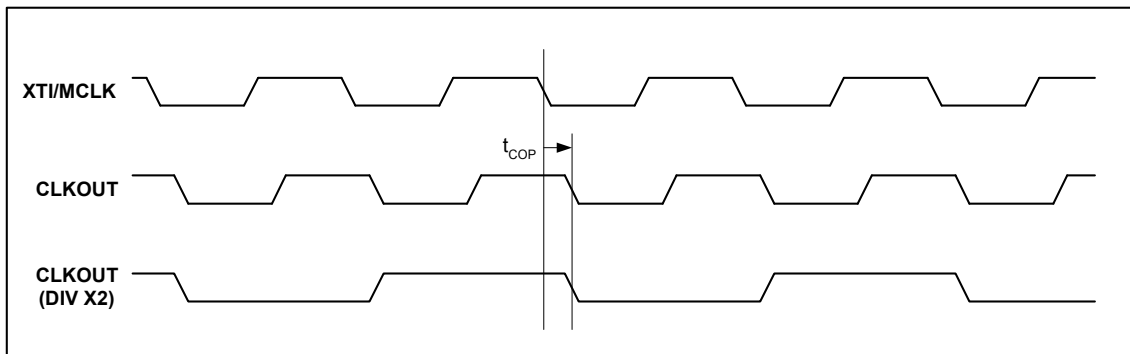

Figure 2 Clock Out Timing Requirements

Test Conditions

AVDD, HPVDD, DBVDD = 3.3V, AGND = 0V, DCVDD = 1.5V, DGND = 0V, $T_A = +25^\circ\text{C}$, Slave Mode $f_s = 48\text{kHz}$, XT1/MCLK = 256fs unless otherwise stated.

PARAMETER	SYMBOL	TEST CONDITIONS	MIN	TYP	MAX	UNIT
System Clock Timing Information						
CLKOUT propagation delay from XT1/MCLK falling edge	t_{COP}		0		10	ns

DIGITAL AUDIO INTERFACE – MASTER MODE

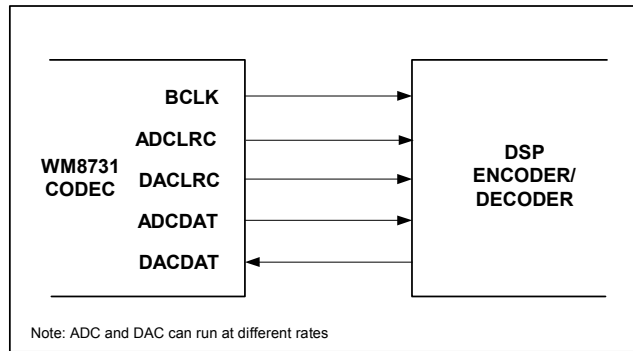

Figure 3 Master Mode Connection

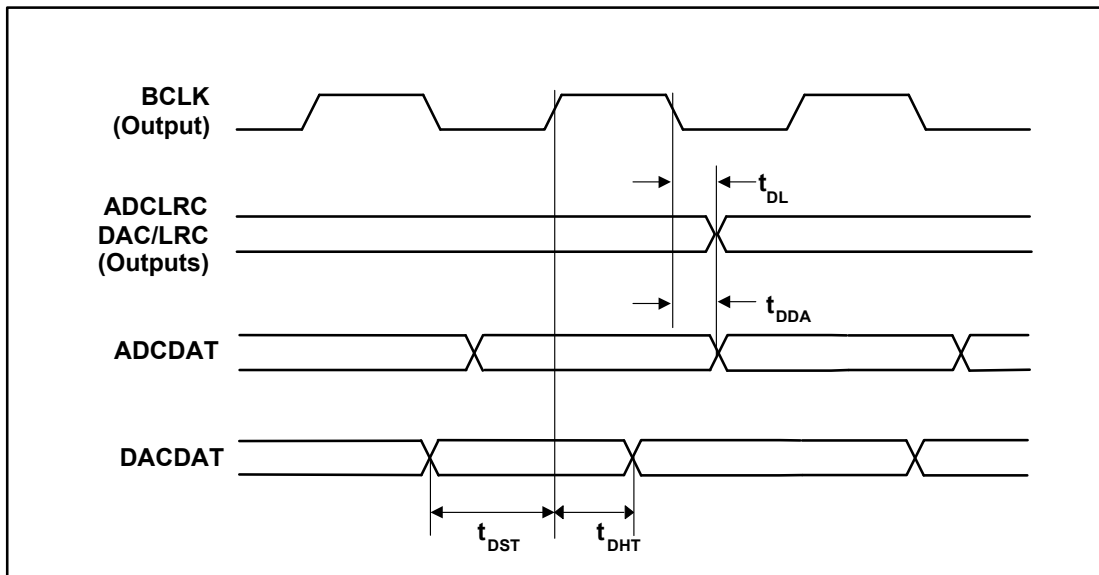

Figure 4 Digital Audio Data Timing – Master Mode

Test Conditions

AVDD, HPVDD, DBDD = 3.3V, AGND = 0V, DCVDD = 1.5V, DGND = 0V, TA = +25°C, Slave Mode, fs = 48kHz, XT1/MCLK = 256fs unless otherwise stated.

PARAMETER	SYMBOL	TEST CONDITIONS	MIN	TYP	MAX	UNIT
Audio Data Input Timing Information						
ADCLRC/DACLRC propagation delay from BCLK falling edge	t _{DL}		0		10	ns
ADCDAT propagation delay from BCLK falling edge	t _{DDA}		0		35	ns
DACDAT setup time to BCLK rising edge	t _{DST}		10			ns
DACDAT hold time from BCLK rising edge	t _{DHT}		10			ns

DIGITAL AUDIO INTERFACE – SLAVE MODE

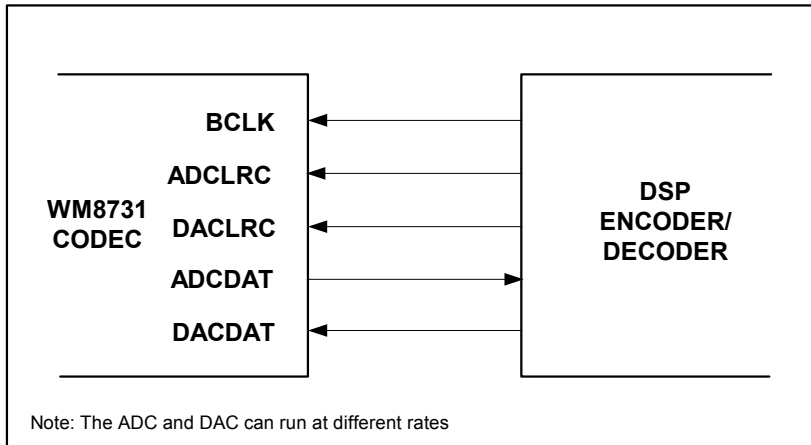

Figure 5 Slave Mode Connection

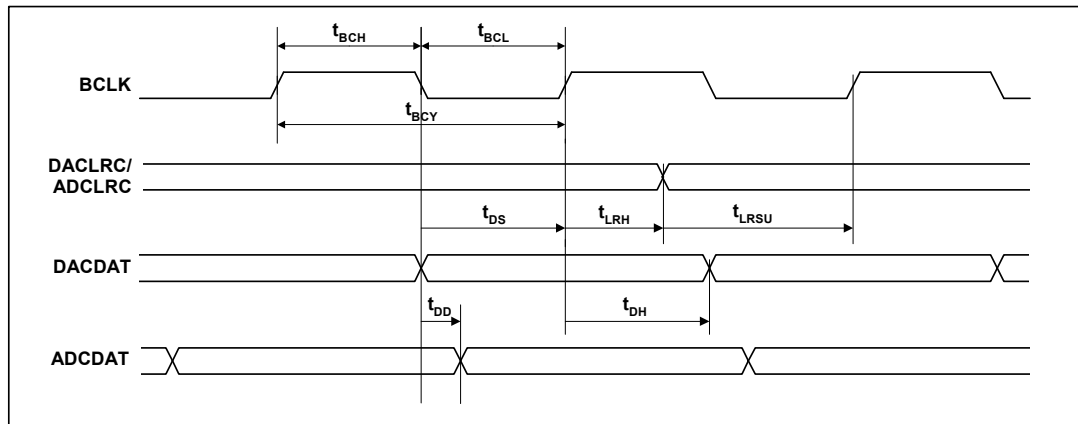

Figure 6 Digital Audio Data Timing – Slave Mode

Test Conditions

AVDD, HPVDD, DBVDD = 3.3V, AGND = 0V, DCVDD = 1.5V, DGND = 0V, T_A = +25°C, Slave Mode, fs = 48kHz, XT1/MCLK = 256fs unless otherwise stated.

PARAMETER	SYMBOL	TEST CONDITIONS	MIN	TYP	MAX	UNIT
Audio Data Input Timing Information						
BCLK cycle time	t _{BCY}		50			ns
BCLK pulse width high	t _{BCH}		20			ns
BCLK pulse width low	t _{BCL}		20			ns
DACLRC/ADCLRC set-up time to BCLK rising edge	t _{LRSU}		10			ns
DACLRC/ADCLRC hold time from BCLK rising edge	t _{LRH}		10			ns
DACDAT set-up time to BCLK rising edge	t _{DS}		10			ns
DACDAT hold time from BCLK rising edge	t _{DH}		10			ns
ADCDAT propagation delay from BCLK falling edge	t _{DD}		0		35	ns

MPU INTERFACE TIMING

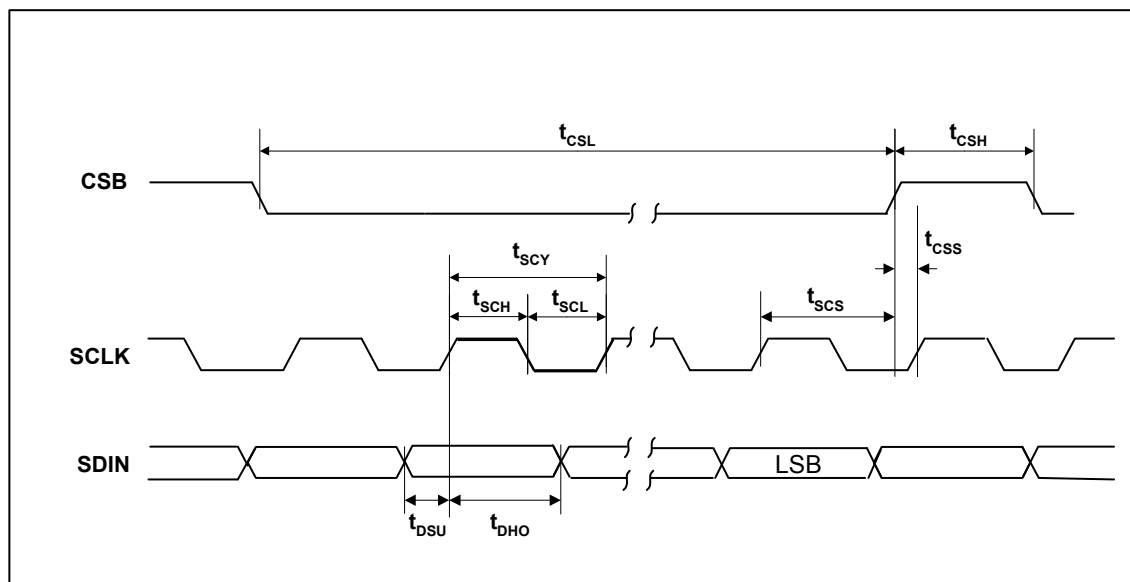

Figure 7 Program Register Input Timing - 3-Wire MPU Serial Control Mode

Test Conditions

AVDD, HPVDD, DBVDD = 3.3V, AGND = 0V, DCVDD = 1.5V, DGND = 0V, $T_A = +25^\circ\text{C}$, Slave Mode, $f_s = 48\text{kHz}$, XTI/MCLK = 256fs unless otherwise stated.

PARAMETER	SYMBOL	TEST CONDITIONS	MIN	TYP	MAX	UNIT
Program Register Input Information						
SCLK rising edge to CSB rising edge	t_{SCS}		60			ns
SCLK pulse cycle time	t_{SCY}		80			ns
SCLK pulse width low	t_{SCL}		20			ns
SCLK pulse width high	t_{SCH}		20			ns
SDIN to SCLK set-up time	t_{DSU}		20			ns
SCLK to SDIN hold time	t_{DHO}		20			ns
CSB pulse width low	t_{CSL}		20			ns
CSB pulse width high	t_{CSH}		20			ns
CSB rising to SCLK rising	t_{CSS}		20			ns

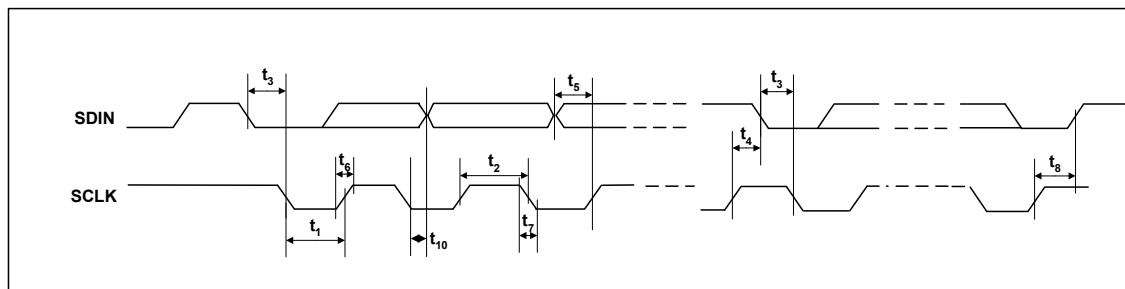

Figure 8 Program Register Input Timing – 2-Wire MPU Serial Control Mode

Test Conditions

AVDD, HPVDD, DBVDD = 3.3V, AGND = 0V, DCVDD = 1.5V, DGND = 0V, $T_A = +25^\circ\text{C}$, Slave Mode, $f_s = 48\text{kHz}$, XTI/MCLK = 256fs unless otherwise stated.

PARAMETER	SYMBOL	TEST CONDITIONS	MIN	TYP	MAX	UNIT
Program Register Input Information						
SCLK Frequency			0		526	kHz
SCLK Low Pulsewidth	t_1		1.3			us
SCLK High Pulsewidth	t_2		600			ns
Hold Time (Start Condition)	t_3		600			ns
Setup Time (Start Condition)	t_4		600			ns
Data Setup Time	t_5		100			ns
SDIN, SCLK Rise Time	t_6				300	ns
SDIN, SCLK Fall Time	t_7				300	ns
Setup Time (Stop Condition)	t_8		600			ns
Data Hold Time	t_{10}				900	ns

DEVICE DESCRIPTION

INTRODUCTION

The WM8731/L is a low power audio CODEC designed specifically for portable audio products. Its features, performance and low power consumption make it ideal for portable MP3 players and portable mini-disc players.

The CODEC includes line and microphone inputs to the on-board ADC, line and headphone outputs from the on-board DAC, a crystal oscillator, configurable digital audio interface and a choice of 2 or 3 wire MPU control interface. It is fully compatible and an ideal partner for a range of industry standard microprocessors, controllers and DSPs.

The CODEC includes three low noise inputs - mono microphone and stereo line. Line inputs have +12dB to -34dB logarithmic volume level adjustments and mute. The Microphone input has -6dB to 34dB volume level adjustment. An electret microphone bias level is also available. All the required input filtering is contained within the device with no external components required.

The on-board stereo analogue to digital converter (ADC) is of a high quality using a multi-bit high-order oversampling architecture delivering optimum performance with low power consumption. The output from the ADC is available on the digital audio interface. The ADC includes an optional digital high pass filter to remove unwanted dc components from the audio signal.

The on-board digital to analogue converter (DAC) accepts digital audio from the digital audio interface. Digital filter de-emphasis at 32kHz, 44.1kHz and 48kHz can be applied to the digital data under software control. The DAC employs a high quality multi-bit high-order oversampling architecture to again deliver optimum performance with low power consumption.

The DAC outputs, Microphone (SIDETONE) and Line Inputs (BYPASS) are available both at line level and through a headphone amplifier capable of efficiently driving low impedance headphones. The headphone output volume is adjustable in the analogue domain over a range of +6dB to -73dB and can be muted.

The design of the WM8731/L has given much attention to power consumption without compromising performance. It includes the ability to power off selective parts of the circuitry under software control, thus conserving power. Nine separate power save modes be configured under software control including a standby and power off mode.

Special techniques allow the audio to be muted and the device safely placed into standby, sections of the device powered off and volume levels adjusted without any audible clicks, pops or zipper noises. Therefore standby and power off modes maybe used dynamically under software control, whenever recording or playing is not required.

The device caters for a number of different sampling rates including industry standard 8kHz, 32kHz, 44.1kHz, 48kHz, 88.2kHz and 96kHz. Additionally, the device has an ADC and DAC that can operate at different sample rates.

There are two unique schemes featured within the programmable sample rates of the WM8731/L: Normal industry standard 256/384fs sampling mode may be used, with the added ability to mix different sampling rates. Also a special USB mode is included, whereby all audio sampling rates can be generated from a 12.00MHZ USB clock. Thus, for example, the ADC can record to the DSP at 44.1kHz and be played back from the CODEC at 8kHz with no external digital signal processing required. The digital filters used at for both record and playback are optimised for each sampling rate used.

The digitised output is available in a number of audio data formats I²S, DSP Mode (a burst mode in which frame sync plus 2 data packed words are transmitted), MSB-First, left justified and MSB-First, right justified. The digital audio interface can operate in both master or slave modes.

The software control uses either 2 or 3-wire MPU interface.

A crystal oscillator is included on board the device. The device can generate the system master clock or alternatively it can accept an external master clock from the audio system.

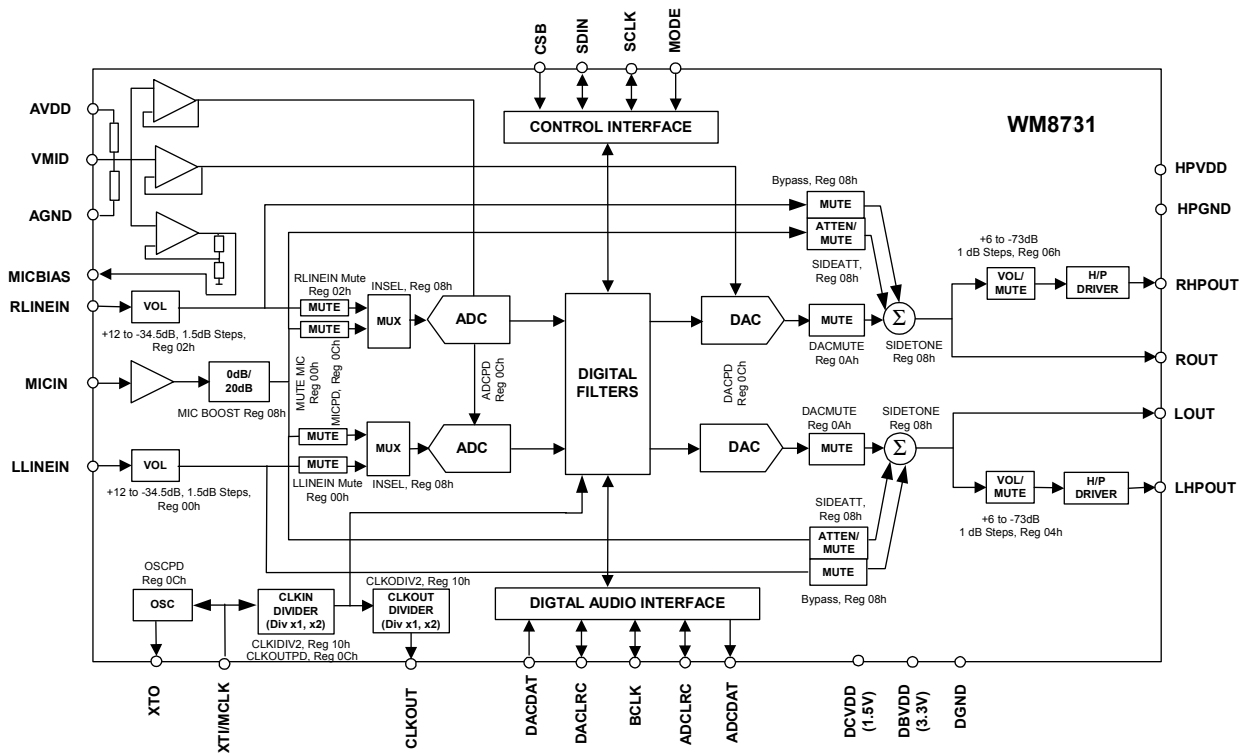

Figure 9 Functional Block Diagram

AUDIO SIGNAL PATH

LINE INPUTS

The WM8731/L provides Left and Right channel line inputs (RLINEIN and LLINEIN). The inputs are high impedance and low capacitance, thus ideally suited to receiving line level signals from external hi-fi or audio equipment.

Both line inputs include independent programmable volume level adjustments and ADC input mute. The scheme is illustrated in Figure 10. Passive RF and active Anti-Alias filters are also incorporated within the line inputs. These prevent high frequencies aliasing into the audio band or otherwise degrading performance.

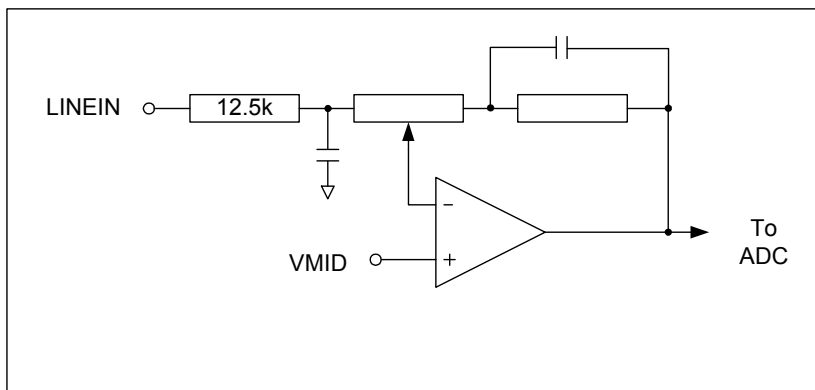

Figure 10 Line Input Schematic

The gain between the line inputs and the ADC is logarithmically adjustable from +12dB to -34.5dB in 1.5dB steps under software control. The ADC Full Scale input is 1.0V rms at AVDD = 3.3 volts. Any voltage greater than full scale will possibly overload the ADC and cause distortion. Note that the full scale input tracks directly with AVDD. The gain is independently adjustable on both Right and Left Line Inputs. However, by setting the INBOTH bit whilst programming the volume control, both channels are simultaneously updated with the same value. Use of INBOTH reduces the required number of software writes required. The line inputs to the ADC can be muted in the analogue domain under software control. The software control registers are shown Table 3. Note that the Line Input Mute only mutes the input to the ADC, this will still allow the Line Input signal to pass to the line output in Bypass Mode.

REGISTER ADDRESS	BIT	LABEL	DEFAULT	DESCRIPTION
0000000 Left Line In	4:0	LINVOL[4:0]	10111 (0dB)	Left Channel Line Input Volume Control 11111 = +12dB . . . 1.5dB steps down to 00000 = -34.5dB
	7	LINMUTE	1	Left Channel Line Input Mute to ADC 1 = Enable Mute 0 = Disable Mute
	8	LRINBOTH	0	Left to Right Channel Line Input Volume and Mute Data Load Control 1 = Enable Simultaneous Load of LINVOL[4:0] and LINMUTE to RINVOL[4:0] and RINMUTE 0 = Disable Simultaneous Load
0000001 Right Line In	4:0	RINVOL[4:0]	10111 (0dB)	Right Channel Line Input Volume Control 11111 = +12dB . . . 1.5dB steps down to 00000 = -34.5dB
	7	RINMUTE	1	Right Channel Line Input Mute to ADC 1 = Enable Mute 0 = Disable Mute
	8	RLINBOTH	0	Right to Left Channel Line Input Volume and Mute Data Load Control 1 = Enable Simultaneous Load of RINVOL[4:0] and RINMUTE to LINVOL[4:0] and LINMUTE 0 = Disable Simultaneous Load

Table 3 Line Input Software Control

The line inputs are biased internally through the operational amplifier to VMID. Whenever the line inputs are muted or the device placed into standby mode, the line inputs are kept biased to VMID using special anti-thump circuitry. This reduces any audible clicks that may otherwise be heard when re-activating the inputs.

The external components required to complete the line input application is shown in the Figure 11.

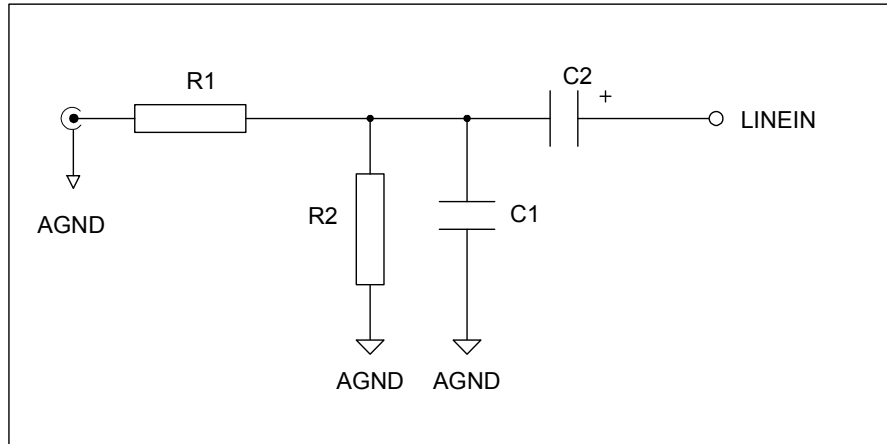

Figure 11 Line Input Application Drawing

For interfacing to a typical CD system, it is recommended that the input is scaled to ensure that there is no clipping of the signal. R1 = 5.6k, R2 = 5.6k, C1 = 220pF, C2 = 1µF.

R1 and R2 form a resistive divider to attenuate the 2 Vrms output from a CD player to a 1 Vrms level, so avoiding overloading the inputs. R2 also provides a discharge path for C2, thus preventing the input to C2 charging to an excessive voltage which may otherwise damage any equipment connected that is not suitably protected against high voltages. C1 forms an RF low pass filter for increasing the rejection of RF interference picked up on any cables. C2 forms a DC blocking capacitor to remove the DC path between the WM8731/L and the driving audio equipment. C2 together with the input impedance of the WM8731/L form a high pass filter.

MICROPHONE INPUT

MICIN is a high impedance, low capacitance input suitable for connection to a wide range of monophonic microphones of different dynamics and sensitivities.

The MICIN includes programmable volume adjustments and a mute function. The scheme is shown in Figure 12. Passive RF and active Anti-Alias filters are also incorporated within the microphone inputs. These allow a matched interface to the multi-bit oversampling ADC and preventing high frequencies aliasing into the audio band or otherwise degrading performance.

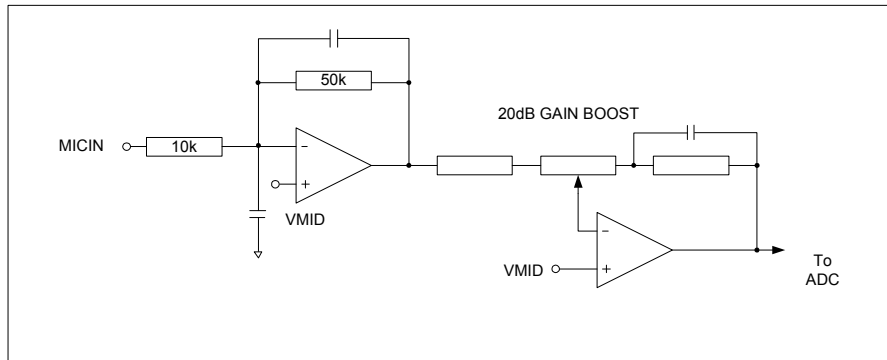

Figure 12 Microphone Input Schematic

There are 2 stages of gain made up of two low noise inverting operational amplifiers.

The 1st stage comprises a nominal gain of $G1 = 50k/10k = 5$. By adding an external resistor (Rmic) in series with MICIN the gain of stage can be adjusted. For example adding Rmic = 40K sets the gain of stage 1 to x1 (0dB). The equation below can be used to calculate the gain versus Rmic.

$$G1 = 50k / (Rmic + 10k)$$

Or alternatively to calculate the value of Rmic to achieve a given gain, G1.

$$Rmic = (50k/G1) - 10k$$

The internal 50k and 10k resistors have a tolerance of 15%. For Rmicext = 90k G = 0.5 (-6dB) and for Rmicext = 0 G = x10 (14dB).

The 2nd stage comprises a 0dB gain stage that can be software configured to provide a fixed 20dB of gain for low sensitivity microphones.

The microphone input can therefore be configured with a variable gain of between -6dB and 14dB on the 1st stage, and an additional fixed 0dB or 20dB on the 2nd stage. This allows for all gains to the input signal in the range -6dB to 34dB to be catered for.

The ADC Full Scale input is 1.0V rms at AVDD = 3.3 volts. Any voltage greater than full scale will possibly overload the ADC and cause distortion. Note that the full scale input tracks directly with AVDD. Stage 1 and Stage 2 gains should be configured so that the ADC receives a maximum signal equal to its full scale for maximising the signal to noise.

The software control for the MICIN is shown in Table 4. Note that the Microphone Mute only mutes the input to the ADC, this will still allow the Microphone Input signal to pass to the line output in Sidetone Mode.

REGISTER ADDRESS	BIT	LABEL	DEFAULT	DESCRIPTION
0000100 Analogue Audio Path Control	0	MICBOOST	0	Microphone Input Level Boost 1 = Enable Boost 0 = Disable Boost
	1	MUTEMIC	1	Line Input Mute to ADC 1 = Enable Mute 0 = Disable Mute

Table 4 Microphone Input Software Control

The microphone input is biased internally through the operational amplifier to VMID. Whenever the line inputs are muted the MICIN input is kept biased to VMID using special anti-thump circuitry. This reduces any audible clicks that may otherwise be heard when re-activating the input.

The application drawing for the microphone is shown in Figure 13.

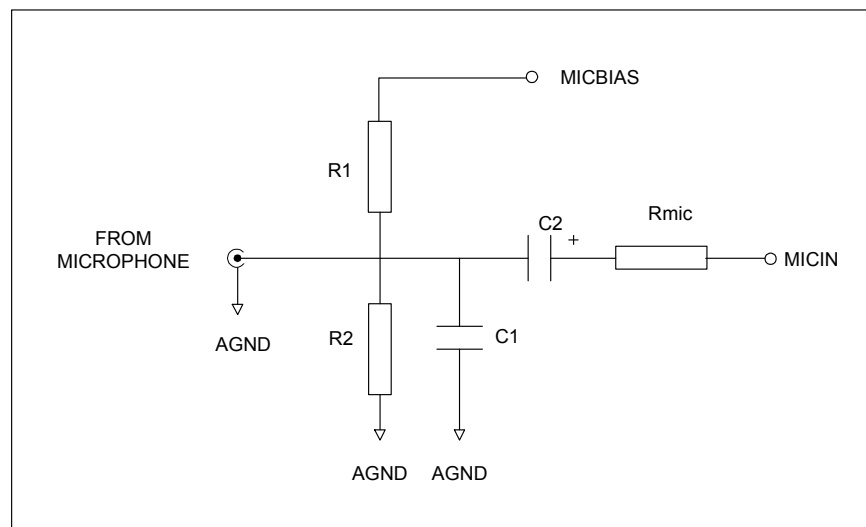

Figure 13 Microphone Input and Bias Application Drawing

Recommended component values are C1 = 220pF (npo ceramic), C2 = 1µF, R1 = 680 Ω, R2 = 47k. Rmic values depends on gain setting (see above).

R1 and R2 form part of the biasing network (refer to Microphone Bias section below). R1 connected to MICBIAS is necessary only for electret type microphones that require a voltage bias. R2 should always be present to prevent the microphone input from charging to a high voltage which may damage the microphone on connection. R1 and R2 should be large so as not to attenuate the signal from the microphone, which can have source impedance greater than 2k. C1 together with the source impedance of the microphone and the input impedance of MICIN forms an RF filter. C2 is a DC blocking capacitor to allow the microphone to be biased at a different DC voltage to the MICIN signal.

MICROPHONE BIAS

The MICBIAS output provides a low noise reference voltage suitable for biasing electret type microphones and the associated external resistor biasing network. Refer to the Microphone Input section for an application drawing and further description.

The scheme for MICBIAS is shown in Figure 14. Note that there is a maximum source current capability of 3mA available for the MICBIAS. This limits the smallest value of external biasing resistors that can safely be used.

Note that the MICBIAS output is not active in standby mode.

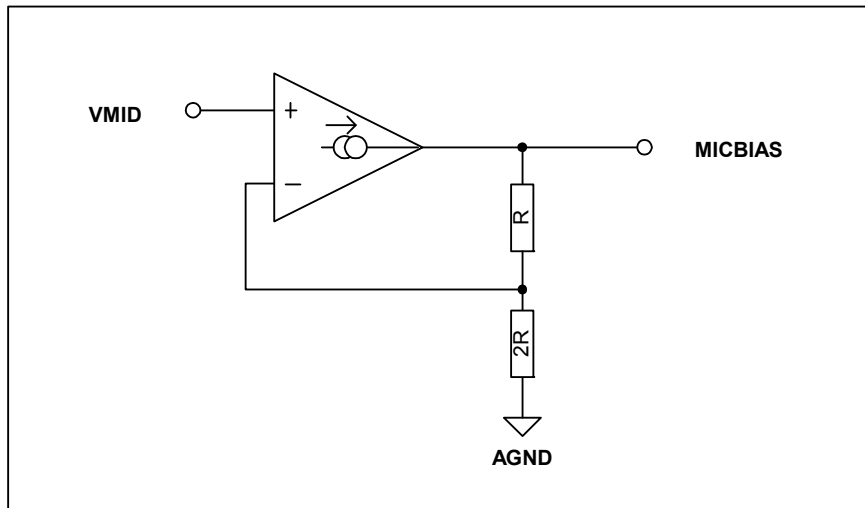

Figure 14 Microphone Bias Schematic

ADC

The WM8731/L uses a multi-bit oversampled sigma-delta ADC. A single channel of the ADC is illustrated in the Figure 15.

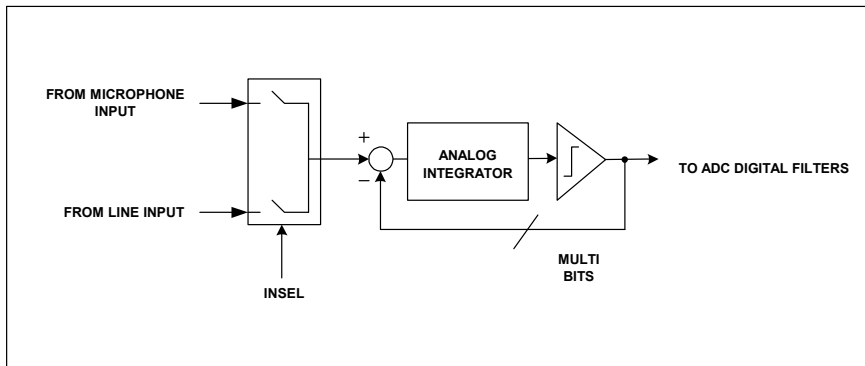

Figure 15 Multi-Bit Oversampling Sigma Delta ADC Schematic

The use of multi-bit feedback and high oversampling rates reduces the effects of jitter and high frequency noise.

The ADC Full Scale input is 1.0V rms at AVDD = 3.3 volts. Any voltage greater than full scale will possibly overload the ADC and cause distortion. Note that the full scale input tracks directly with AVDD.

The device employs a pair of ADCs. The input can be selected from either the Line Inputs or the Microphone input under software control. The two channels cannot be selected independently. The control is shown in Table 5.

REGISTER ADDRESS	BIT	LABEL	DEFAULT	DESCRIPTION
0000100 Analogue Audio Path Control	2	INSEL	0	Microphone/Line Input Select to ADC 1 = Microphone Input Select to ADC 0 = Line Input Select to ADC

Table 5 ADC Software Control

The digital data from the ADC is fed for signal processing to the ADC Filters.

ADC FILTERS

The ADC filters perform true 24 bit signal processing to convert the raw multi-bit oversampled data from the ADC to the correct sampling frequency to be output on the digital audio interface. Figure 16 illustrates the digital filter path.

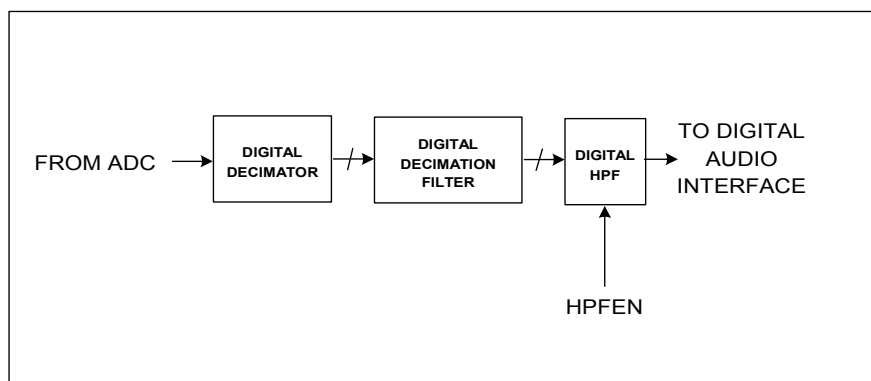

Figure 16 ADC Digital Filter

The ADC digital filters contain a digital high pass filter, selectable via software control. The high-pass filter response detailed in Digital Filter Characteristics. When the high-pass filter is enabled the dc offset is continuously calculated and subtracted from the input signal. By setting HPOR the last calculated dc offset value is stored when the high-pass filter is disabled and will continue to be subtracted from the input signal. If the dc offset changes, the stored and subtracted value will not change unless the high-pass filter is enabled. The software control is shown in Table 6.

REGISTER ADDRESS	BIT	LABEL	DEFAULT	DESCRIPTION
0000101 Digital Audio Path Control	0	ADCHPD	0	ADC High Pass Filter Enable (Digital) 1 = Disable High Pass Filter 0 = Enable High Pass Filter
	4	HPOR	0	Store dc offset when High Pass Filter disabled 1 = store offset 0 = clear offset

Table 6 ADC Software Control

There are several types of ADC filters, frequency and phase responses of these are shown in Digital Filter Characteristics. The filter types are automatically configured depending on the sample rate chosen. Refer to the sample rate section for more details.

DAC FILTERS

The DAC filters perform true 24 bit signal processing to convert the incoming digital audio data from the digital audio interface at the specified sample rate to multi-bit oversampled data for processing by the analogue DAC. Figure 17 illustrates the DAC digital filter path.

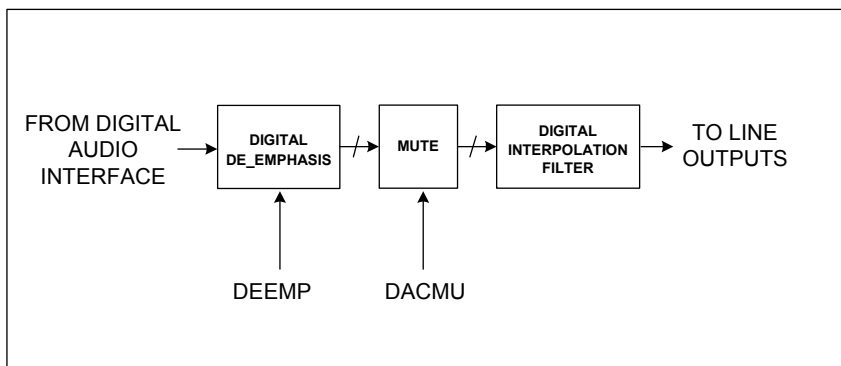

Figure 17 DAC Filter Schematic

The DAC digital filter can apply digital de-emphasis under software control, as shown in Table 7. The DAC can also perform a soft mute where the audio data is digitally brought to a mute level. This removes any abrupt step changes in the audio that might otherwise result in audible clicks in the audio outputs.

REGISTER ADDRESS	BIT	LABEL	DEFAULT	DESCRIPTION
0000101 Digital Audio Path Control	2:1	DEEMP[1:0]	00	De-emphasis Control (Digital) 11 = 48kHz 10 = 44.1kHz 01 = 32kHz 00 = Disable
	3	DACMU	1	DAC Soft Mute Control (Digital) 1 = Enable soft mute 0 = Disable soft mute

Table 7 DAC Software Control

Notes:

1. Not valid when SR[3:0] = 1111 or 0111.
2. To ensure correct DACMU operation at fs = 88.2kHz, set SR[3:0] = 1000.
3. To ensure correct DACMU operation at fs = 96kHz, set SR[3:0] = 0000.

DAC

The WM8731/L employs a multi-bit sigma delta oversampling digital to analogue converter. The scheme for the converter is illustrated in Figure 18.

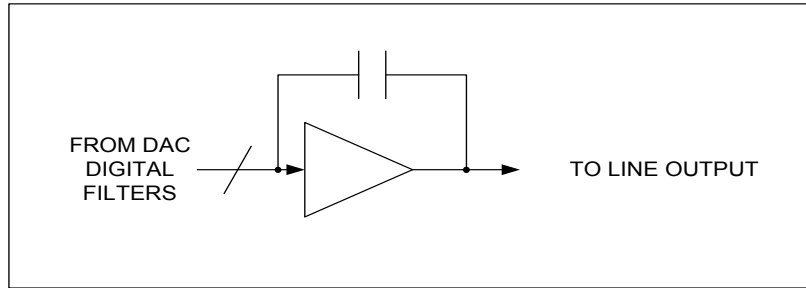

Figure 18 Multi-Bit Oversampling Sigma Delta Schematic

The DAC converts the multi-level digital audio data stream from the DAC digital filters into high quality analogue audio.

LINE OUTPUTS

The WM8731/L provides two low impedance line outputs LLINEOUT and RLINEOUT, suitable for driving typical line loads of impedance 10K and capacitance 50pF. The line output is used to selectively sum the outputs from the DAC or/and the Line inputs in bypass mode.

The LLINEOUT and RLINEOUT outputs are only available at a line output level and are not level adjustable in the analogue domain, having a fixed gain of 0dB. The level is fixed such that at the DAC full scale level the output level is 1.0Vrms at AVDD = 3.3 volts. Note that the DAC full scale level tracks directly with AVDD. The scheme is shown in Figure 19. The line output includes a low order audio low pass filter for removing out-of band components from the sigma-delta DAC. Therefore no further external filtering is required in most applications.

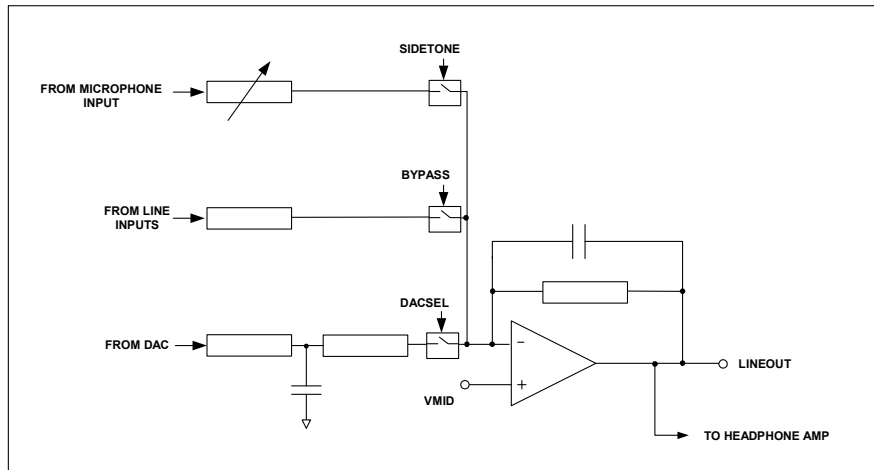

Figure 19 Line Output Schematic

The DAC output, Line Input and microphone are summed into the Line Output. In DAC mode only the output from the DAC is routed to the line outputs. In Bypass mode the Line Input is summed into the Line Outputs. In Side Tone mode the Microphone Input is summed into the Line Output. These features can be used for either over-dubbing or, if the DAC is muted, as a pure analogue bypass or Side Tone feature, so avoiding any digital signal processing.

The line output is muted by either muting the DAC (analogue) or Soft Muting (digital) and disabling the BYPASS and SIDETONE paths. Refer to the DAC section for more details. Whenever the DAC is muted or the device placed into standby mode the DC voltage is maintained at the line outputs to prevent any audible clicks from being present.

The software control for the line outputs is shown in Table 8.

REGISTER ADDRESS	BIT	LABEL	DEFAULT	DESCRIPTION
0000100 Analogue Audio Path Control	3	BYPASS	1	Bypass Switch 1 = Enable Bypass 0 = Disable Bypass
	4	DACSEL	0	DAC Select 1 = Select DAC 0 = Don't select DAC
	5	SIDETONE	0	Side Tone Switch 1 = Enable SideTone 0 = Disable Side Tone

Table 8 Output Software Control

The recommended external components are shown in Figure 20.

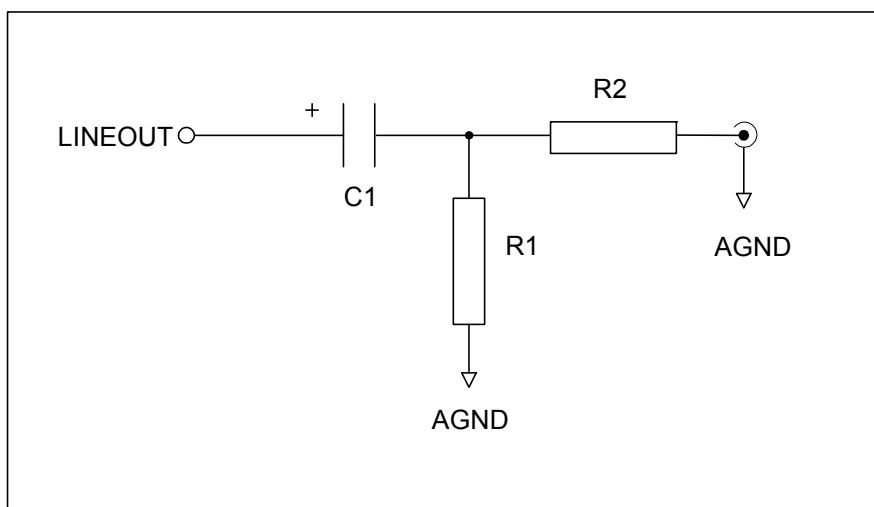

Figure 20 Line Outputs Application Drawing

Recommended values are C1 = 10 μ F, R1 = 47k, R2 = 100 Ω .

C1 forms a DC blocking capacitor to the line outputs. R1 prevents the output voltage from drifting so protecting equipment connected to the line output. R2 forms a de-coupling resistor preventing abnormal loads from disturbing the device. Note that poor choice of dielectric material for C1 can have dramatic effects on the measured signal distortion at the output

HEADPHONE AMPLIFIER

The WM8731/L has a stereo headphone output available on LHPOUT and RHPOUT. The output is designed specifically for driving 16 or 32 Ω headphones with maximum efficiency and low power consumption. The headphone output includes a high quality volume level adjustment and mute function.

The scheme of the circuit is shown in Figure 21.

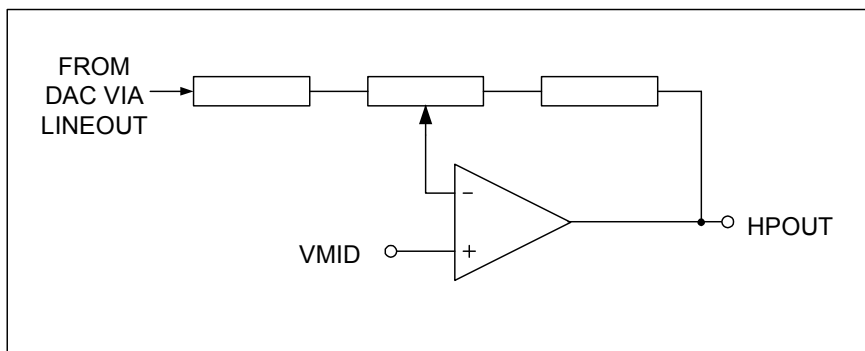

Figure 21 Headphone Amplifier Schematic

LHPOUT and RHPOUT volumes can be independently adjusted under software control using the LHPVOL[6:0] and RHPVOL[6:0] bits respectively of the headphone output control registers. The adjustment is logarithmic with an 80dB range in 1dB steps from +6dB to -73dB.

The headphone outputs can be separately muted by writing codes less than 0110000 to LHPVOL[6:0] or RHPVOL[6:0]L bits. Whenever the headphone outputs are muted or the device placed into standby mode, the DC voltage is maintained at the line outputs to prevent any audible clicks from being present.

A zero cross detect circuit is provided at the input to the headphones under the control of the LZCEN and RZCEN bits of the headphone output control register. Using these controls the volume control values are only updated when the input signal to the gain stage is close to the analogue ground level. This minimises audible clicks and zipper noise as the gain values are changed or the device muted. Note that this circuit has no time out so if only DC levels are being applied to the gain stage input of more than approximately 20mV, then the gain will not be updated. This zero cross function is enabled when the LZCEN and RZCEN bit is set high during a volume register write. If there is concern that a DC level may have blocked a volume change (one made with LZCEN or RZCEN set high) then a subsequent volume write of the same value, but with the LZCEN or RZCEN bit set low will force a volume update, regardless of the DC level.

LHPOUT and RHPOUT volume and zero-cross setting can be changed independently. Alternatively, the user can lock the two channels together, allowing both to be updated simultaneously, halving the number of serial writes required, provided that the same gain is needed for both channels. This is achieved through writing to the HPBOTH bit of the control register. Setting LRHPBOTH whilst writing to LHPVOL and LZCEN will simultaneously update the Right Headphone controls similarly. The corresponding effect on updating RLHPBOTH is also achieved.

The software control is given in Table 9.

REGISTER ADDRESS	BIT	LABEL	DEFAULT	DESCRIPTION
0000010 Left Headphone Out	6:0	LHPVOL[6:0]	1111001 (0dB)	Left Channel Headphone Output Volume Control 1111111 = +6dB . . 1dB steps down to 0110000 = -73dB 0000000 to 0101111 = MUTE
	7	LZCEN	0	Left Channel Zero Cross detect Enable 1 = Enable 0 = Disable
	8	LRHPBOTH	0	Left to Right Channel Headphone Volume, Mute and Zero Cross Data Load Control 1 = Enable Simultaneous Load of LHPVOL[6:0] and LZCEN to RHPVOL[6:0] and RZCEN 0 = Disable Simultaneous Load
0000011 Right Headphone Out	6:0	RHPVOL[6:0]	1111001 (0dB)	Right Channel Headphone Output Volume Control 1111111 = +6dB . . 1dB steps down to 0110000 = -73dB 0000000 to 0101111 = MUTE
	7	RZCEN	0	Right Channel Zero Cross Detect Enable 1 = Enable 0 = Disable
	8	RLHPBOTH	0	Right to Left Channel Headphone Volume, Mute and Zero Cross Data Load Control 1 = Enable Simultaneous Load of RHPVOL[6:0] and RZCEN to LHPVOL[6:0] and LZCEN 0 = Disable Simultaneous Load

Table 9 Headphone Output Software Control

The recommended external components required to complete the application are shown in Figure 22.

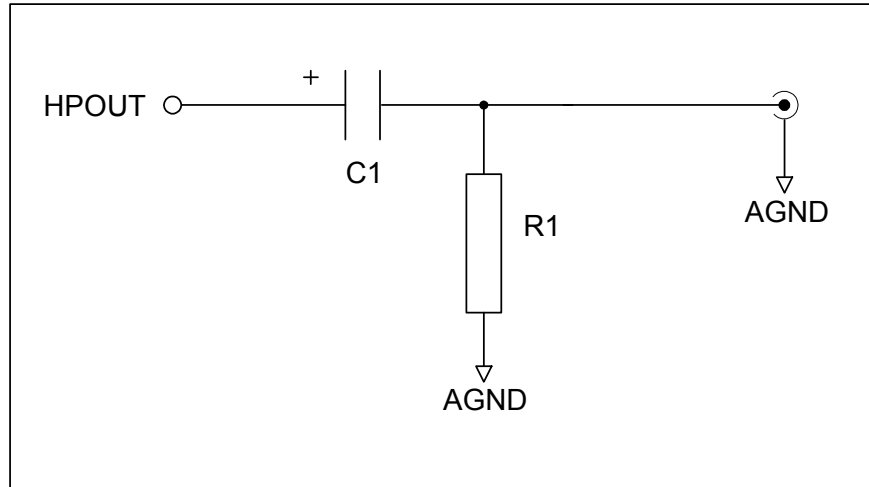

Figure 22 Headphone Output Application Drawing

Recommended values are C1 = 220uF (10V electrolytic), R1 = 47k

C1 forms a DC blocking capacitor to isolate the dc of the HPOUT from the headphones. R1 form a pull down resistor to discharge C1 to prevent the voltage at the connection to the headphones from rising to a level that may damage the headphones.

BYPASS MODE

The WM8731/L includes a bypass mode whereby analogue line inputs are routed directly to the analogue line outputs and headphone outputs. The scheme for this is in Figure 23.

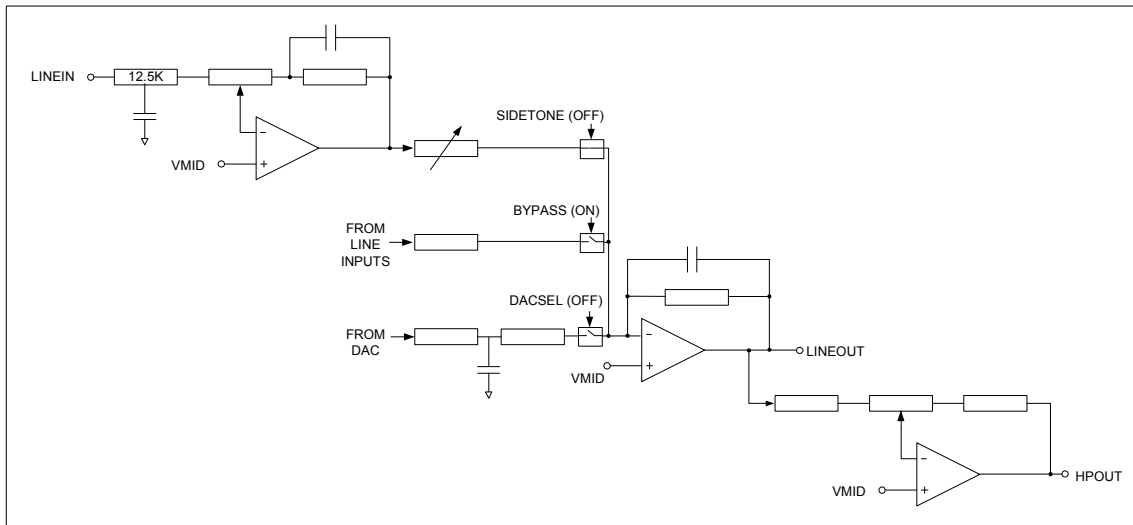

Figure 23 Signal Routing in Bypass Mode

The bypass mode is selected under software control using the BYPASS microphone bit as shown in Table 10. In true bypass mode, the output from the DAC (DACSEL) and (SIDETONE) should be deselected from the line output block. However this can also be used to sum the DAC output, Line Inputs together and microphone inputs. The analogue line input and headphone output volume controls and mutes are still operational in bypass mode. The 0dB gain setting is recommended for the Line Input volume control to avoid distortion. The maximum signal at any point in the bypass path must be no greater than 1.0V rms at AVDD = 3.3V, to avoid distortion. This amplitude tracks linearly with AVDD. This means that if the DAC is producing a 1Vrms signal, and it is being summed with 1Vrms line BYPASS signal, the resulting LINEOP signal will be clipped.

REGISTER ADDRESS	BIT	LABEL	DEFAULT	DESCRIPTION
0000100 Analogue Audio Path Control	3	BYPASS	1	Bypass Switch (Analogue) 1 = Enable Bypass 0 = Disable Bypass

Table 10 Bypass Mode Software Control

SIDETONE MODE

The WM8731/L also includes a side tone mode where the microphone input is routed to line and headphone outputs. The scheme for this is shown in Figure 24.

The side tone mode allows the microphone input to be attenuated to the outputs for telephone and headset applications.

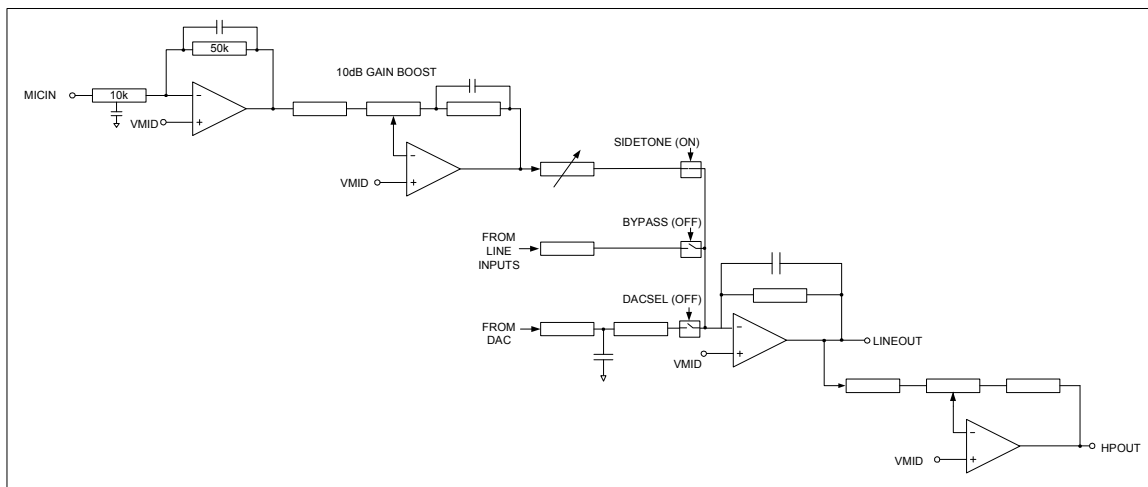

Figure 24 Side Tone Mode Schematic

REGISTER ADDRESS	BIT	LABEL	DEFAULT	DESCRIPTION
0000100 Analogue Audio Path Control	5	SIDETONE	0	Side Tone Switch (Analogue) 1 = Enable Side Tone 0 = Disable Side Tone
	7:6	SIDEATT[1:0]	00	Side Tone Attenuation 11 = -15dB 10 = -12dB 01 = -9dB 00 = -6dB

Table 11 Side Tone Mode Table

The side tone mode and attenuation is selected under software control using the SIDETONE bit as shown in Table 11. In true side tone the output from the DAC (DACSEL) and line inputs (BYPASS) should be deselected from the line output block. However, this can also be used to sum the DAC output, line inputs and microphone inputs together. The microphone boost gain control and headphone output volume control and mutes are still operational in side tone mode. The maximum signal at any point in the side tone path must be no greater than 1.0V rms at VDD = 3.3V, to avoid distortion. This amplitude tracks linearly with AVDD.

DEVICE OPERATION

DEVICE RESETTING

The WM8731/L contains a power on reset circuit that resets the internal state of the device to a known condition. The power on reset is applied as DCVDD powers on and released only after the voltage level of DCVDD crosses a minimum turn off threshold. If DCVDD later falls below a minimum turn on threshold voltage then the power on reset is re-applied. The threshold voltages and associated hysteresis are shown in the Electrical Characteristics table.

The user also has the ability to reset the device to a known state under software control as shown in the table below.

REGISTER ADDRESS	BIT	LABEL	DEFAULT	DESCRIPTION
0001111 Reset Register	8:0	RESET	not reset	Reset Register Writing 00000000 to register resets device

Table 12 Software Control of Reset

When using the software reset. In 3-wire mode the reset is applied on the rising edge of CSB and released on the next rising edge of SCLK. In 2-wire mode the reset is applied for the duration of the ACK signal (approximately 1 SCLK period, refer to Figure 34).

CLOCKING SCHEMES

In a typical digital audio system there is only one central clock source producing a reference clock to which all audio data processing is synchronised. This clock is often referred to as the audio system's Master Clock. To allow WM8731/L to be used in a centrally clocked system, the WM8731/L is capable of either generating this system clock itself or receiving it from an external source as will be discussed.

For applications where it is desirable that the WM8731/L is the system clock source, then clock generation is achieved through the use of a suitable crystal connected between the XT1/MCLK input and XTO output pins (see CRYSTAL OSCILLATOR section).

For applications where a component other than the WM8731/L will generate the reference clock, the external system can be applied directly through the XT1/MCLK input pin with no software configuration necessary. Note that in this situation, the oscillator circuit of the WM8731/L can be safely powered down to conserve power (see POWER DOWN section).

CORE CLOCK

The WM8731/L DSP core can be clocked either by MCLK or MCLK divided by 2. This is controlled by software as shown in Table 13 below.

REGISTER ADDRESS	BIT	LABEL	DEFAULT	DESCRIPTION
0001000 Sampling Control	6	CLKIDIV2	0	Core Clock divider select 1 = Core Clock is MCLK divided by 2 0 = Core Clock is MCLK

Table 13 Software Control of Core Clock

Having a programmable MCLK divider allows the device to be used in applications where higher frequency master Clocks are available. For example the device can support 512fs master clocks whilst fundamentally operating in a 256fs mode.

CRYSTAL OSCILLATOR

The WM8731/L includes a crystal oscillator circuit that allows the audio system's reference clock to be generated on the device. This is available to the rest of the audio system in buffered form on CLKOUT. The crystal oscillator is a low radiation type, designed for low EMI. A typical application circuit is shown in Figure 25.

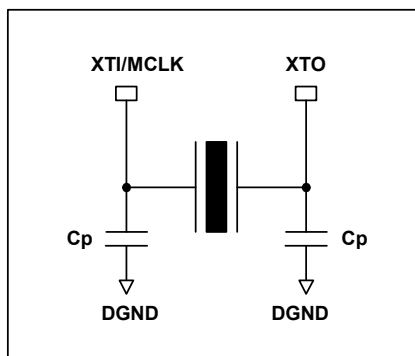

Figure 25 Crystal Oscillator Application Circuit

The WM8731/L crystal oscillator provides an extremely low jitter clock source. Low jitter clocks are a requirement for high quality audio ADC and DACs, regardless of the converter architecture. The WM8731/L architecture is less susceptible than most converter techniques but still requires clocks with less than approximately 1ns of jitter to maintain performance. In applications where there is more than one source for the master clock, it is recommended that the clock is generated by the WM8731/L to minimise such problems.

CLOCKOUT

The Core Clock is internally buffered and made available externally to the audio system on the CLKOUT output pin. CLKOUT provides a replication of the Core Clock, but buffered as suitable for driving external loads.

There is no phase inversion between XT1/MCLK, the Core Clock and CLOCKOUT but there will inevitably be some delay. The delay will be dependent on the load that CLOCKOUT drives. Refer to Electrical Characteristics.

CLKOUT can also be divided by 2 under software control, refer to Table 14. Note that if CLKOUT is not required then the CLKOUT buffer on the WM8731/L can be safely powered down to conserve power (see POWER DOWN section). If the system architect has the choice between using $F_{CLKOUT} = F_{MCLK}$ or $F_{CLKOUT} = F_{MCLK}/2$ in the interface, the latter is recommended to conserve power. When the divide by two is selected CLKOUT changes on the rising edge of MCLK. Please refer to Electrical Characteristics for timing information.

REGISTER ADDRESS	BIT	LABEL	DEFAULT	DESCRIPTION
0001000 Sampling Control	7	CLKODIV2	0	CLKOUT divider select 1 = CLOCKOUT is Core Clock divided by 2 0 = CLOCKOUT is Core Clock

Table 14 Programming CLKOUT

CLKOUT is disabled and set low whenever the device is in reset.

DIGITAL AUDIO INTERFACES

WM8731/L may be operated in either one of the 4 offered audio interface modes. These are:

- Right justified
- Left justified
- I²S
- DSP mode

All four of these modes are MSB first and operate with data 16 to 32 bits.

Note that 32 bit data is not supported in right justified mode.

The digital audio interface takes the data from the internal ADC digital filter and places it on the ADCDAT output. ADCDAT is the formatted digital audio data stream output from the ADC digital filters with left and right channels multiplexed together. ADCLRC is an alignment clock that controls whether Left or Right channel data is present on the ADCDAT lines. ADCDAT and ADCLRC are synchronous with the BCLK signal with each data bit transition signified by a BCLK high to low transition. BCLK may be an input or an output dependent on whether the device is in master or slave mode. Refer to the MASTER/SLAVE OPERATION section

The digital audio interface also receives the digital audio data for the internal DAC digital filters on the DACDAT input. DACDAT is the formatted digital audio data stream output to the DAC digital filters with left and right channels multiplexed together. DACLRC is an alignment clock that controls whether Left or Right channel data is present on DACDAT. DACDAT and DACLRC are synchronous with the BCLK signal with each data bit transition signified by a BCLK high to low transition. DACDAT is always an input. BCLK and DACLRC are either outputs or inputs depending whether the device is in master or slave mode. Refer to the MASTER/SLAVE OPERATION section

There are four digital audio interface formats accommodated by the WM8731/L. These are shown in the figures below. Refer to the Electrical Characteristic section for timing information.

Left Justified mode is where the MSB is available on the first rising edge of BCLK following a ADCLR or DACLRC transition.

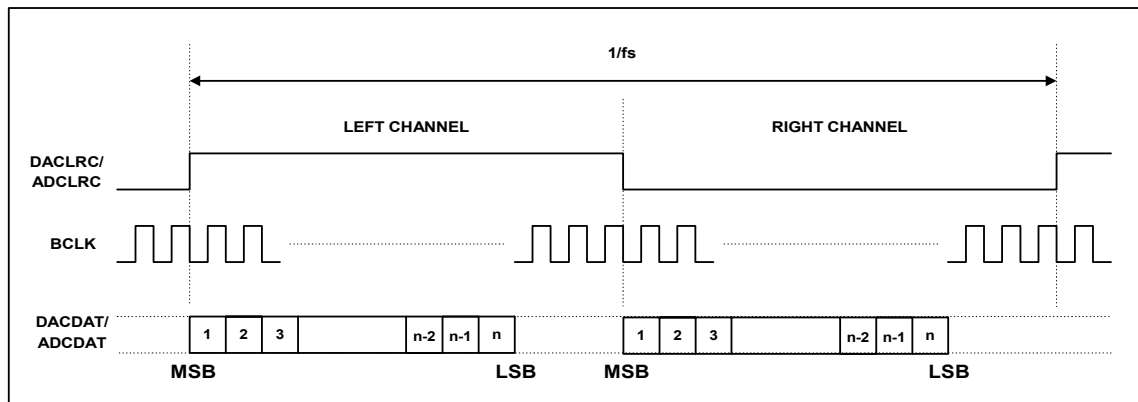

Figure 26 Left Justified Mode

I²S mode is where the MSB is available on the 2nd rising edge of BCLK following a DACLRC or ADCLRC transition.

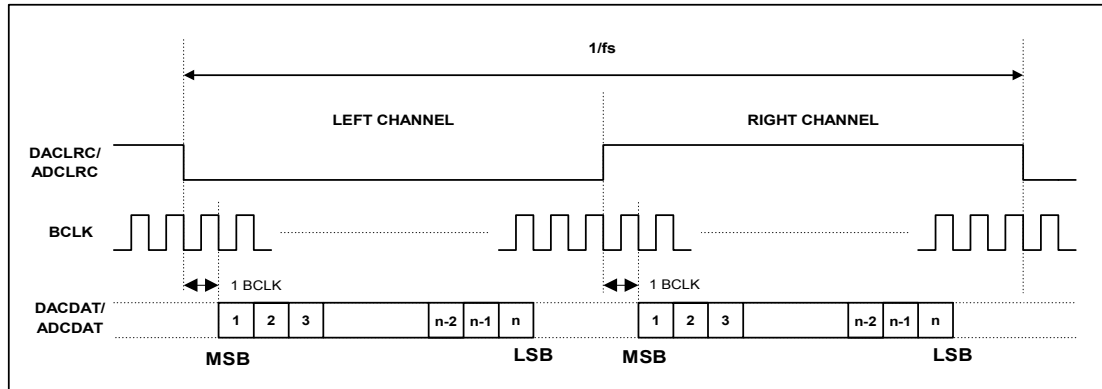

Figure 27 I²S Mode

Right Justified mode is where the LSB is available on the rising edge of BCLK preceding a DACLRC or ADCLRC transition, yet MSB is still transmitted first.

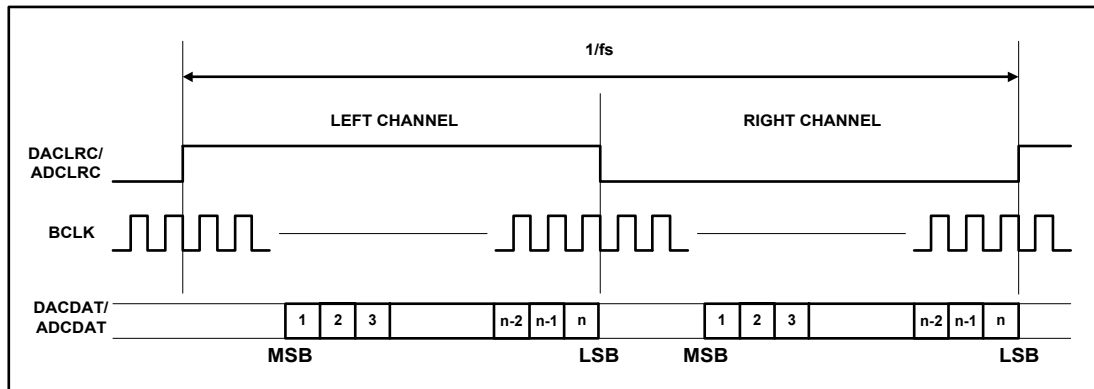

Figure 28 Right Justified Mode

In DSP/PCM mode, the left channel MSB is available on either the 1st (mode B) or 2nd (mode A) rising edge of BCLK (selectable by LRP) following a rising edge of LRC. Right channel data immediately follows left channel data. Depending on word length, BCLK frequency and sample rate, there may be unused BCLK cycles between the LSB of the right channel data and the next sample.

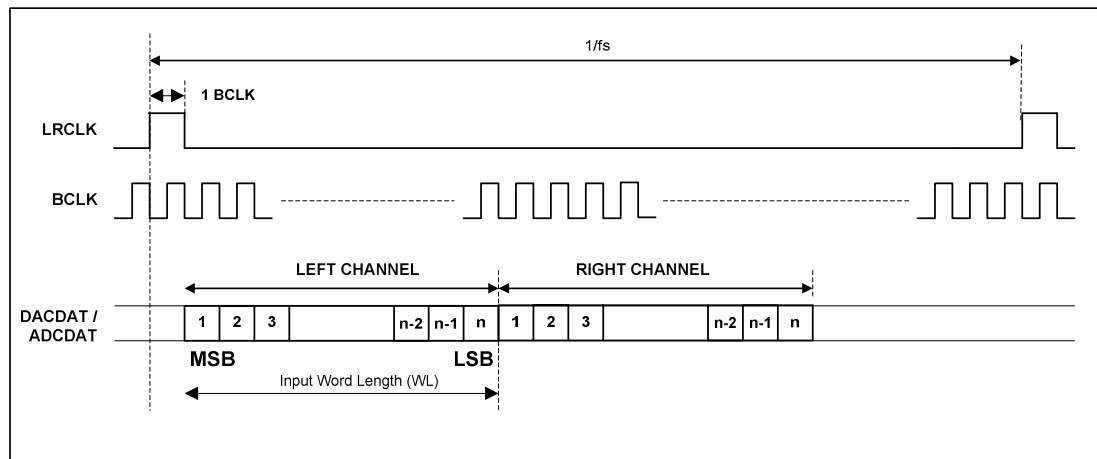

Figure 29 DSP/PCM Mode Audio Interface (mode A, LRP=1)

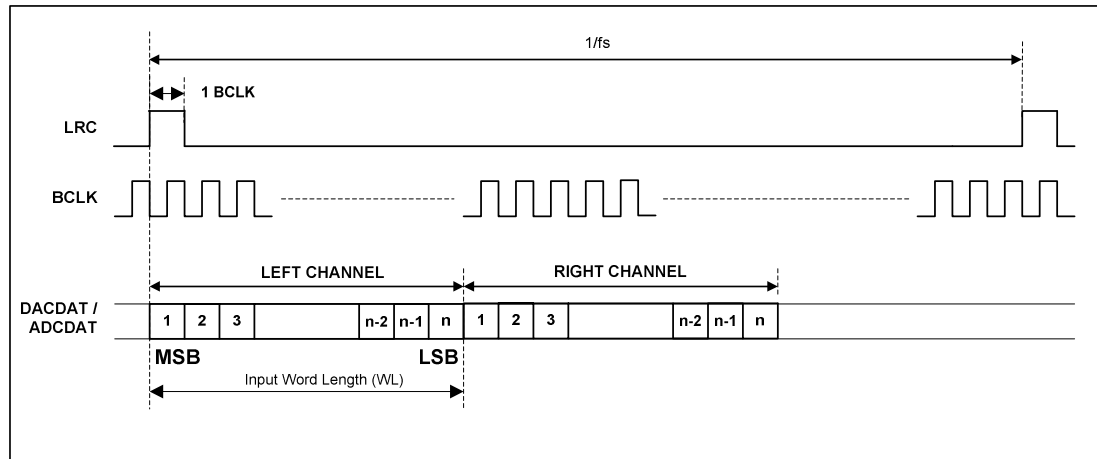

Figure 30 DSP/PCM Mode Audio Interface (mode B, LRP=0)

In all modes DACLRC and ADLRC must always change on the falling edge of BCLK, refer to Figure 26, Figure 27, Figure 28, Figure 29 and Figure 30.

Operating the digital audio interface in DSP mode allows ease of use for supporting the various sample rates and word lengths. The only requirement is that all data is transferred within the correct number of BCLK cycles to suit the chosen word length.

In order for the digital audio interface to offer similar support in the three other modes (Left Justified, I²S and Right Justified), the DACLRC, ADLRC and BCLK frequencies, continuity and mark-space ratios need more careful consideration.

In Slave mode, DACLRC and ADLRC inputs are not required to have a 50:50 mark-space ratio. BCLK input need not be continuous. It is however required that there are sufficient BCLK cycles for each DACLRC/ADLRC transition to clock the chosen data word length. The non-50:50 requirement on the LRCs is of use in some situations such as with a USB 12MHz clock. Here simply dividing down a 12MHz clock within the DSP to generate LRCs and BCLK will not generate the appropriate DACLRC or ADLRC since they will no longer change on the falling edge of BCLK. For example, with 12MHz/32k fs mode there are 375 MCLK per LRC. In these situations DACLRC/ADLRC can be made non 50:50.

In Master mode, DACLRC and ADLRC will be output with a 50:50 mark-space ratio with BCLK output at 64 x base frequency (i.e. 48 kHz). The exception again is in USB mode where BCLK is always 12MHz. So for example in 12MHz/32k fs mode there are 375 master clocks per DACLRC period. Therefore DACLRC and ADLRC outputs will have a mark space ratio of 187:188.

The ADC and DAC digital audio interface modes are software configurable as indicated in Table 14. Note that dynamically changing the software format may result in erroneous operation of the interfaces and is therefore not recommended.

The length of the digital audio data is programmable at 16/20/24 or 32 bits, in I2S or left justified modes only. Refer to the software control table below. The data is signed 2's complement. Both ADC and DAC are fixed at the same data length. The ADC and DAC digital filters process data using 24 bits. If the ADC is programmed to output 16 or 20 bit data then it strips the LSBs from the 24 bit data. If the ADC is programmed to output 32 bits then it packs the LSBs with zeros. If the DAC is programmed to receive 16 or 20 bit data, the WM8731/L packs the LSBs with zeros. If the DAC is programmed to receive 32 bit data, then it strips the LSBs.

The DAC outputs can be swapped under software control using LRP and LRSWAP as shown in Table 15. Stereo samples are normally generated as a Left/Right sampled pair. LRSWAP reverses the order so that a Left sample goes to the right DAC output and a Right sample goes to the left DAC output. LRP swaps the phasing so that a Right/Left sampled pair is expected and preserves the correct channel phase difference.

To accommodate system timing requirements the interpretation of BCLK maybe inverted, this is controlled via the software shown in Table 15. This is especially appropriate for DSP mode.

ADCDAT lines are always outputs. They power up and return from standby low.

DACDAT is always an input. It is expected to be set low by the audio interface controller when the WM8731/L is powered off or in standby.

ADCLRC, DACLRC and BCLK can be either outputs or inputs depending on whether the device is configured as a master or slave. If the device is a master then the DACLRC and BCLK signals are outputs that default low. If the device is a slave then the DACLRC and BCLK are inputs. It is expected that these are set low by the audio interface controller when the WM8731/L is powered off or in standby.

REGISTER ADDRESS	BIT	LABEL	DEFAULT	DESCRIPTION
0000111 Digital Audio Interface Format	1:0	FORMAT[1:0]	10	Audio Data Format Select 11 = DSP Mode, frame sync + 2 data packed words 10 = I ² S Format, MSB-First left-1 justified 01 = MSB-First, left justified 00 = MSB-First, right justified
	3:2	IWL[1:0]	10	Input Audio Data Bit Length Select 11 = 32 bits 10 = 24 bits 01 = 20 bits 00 = 16 bits
	4	LRP	0	DACLRC phase control (in left, right or I ² S modes) 1 = Right Channel DAC data when DACLRC high 0 = Right Channel DAC data when DACLRC low (opposite phasing in I ² S mode) or DSP mode A/B select (in DSP mode only) 1 = MSB is available on 2nd BCLK rising edge after DACLRC rising edge 0 = MSB is available on 1st BCLK rising edge after DACLRC rising edge
	5	LRSWAP	0	DAC Left Right Clock Swap 1 = Right Channel DAC Data Left 0 = Right Channel DAC Data Right
	6	MS	0	Master Slave Mode Control 1 = Enable Master Mode 0 = Enable Slave Mode
	7	BCLKINV	0	Bit Clock Invert 1 = Invert BCLK 0 = Don't invert BCLK

Table 15 Digital Audio Interface Control

Note: If right justified 32 bit mode is selected then the WM8731/L defaults to 24 bits.

MASTER AND SLAVE MODE OPERATION

The WM8731/L can be configured as either a master or slave mode device. As a master mode device the WM8731/L controls sequencing of the data and clocks on the digital audio interface. As a slave device the WM8731/L responds with data to the clocks it receives over the digital audio interface. The mode is set with the MS bit of the control register as shown in Table 16.

REGISTER ADDRESS	BIT	LABEL	DEFAULT	DESCRIPTION
0000111 Digital Audio Interface Format	6	MS	0	Master Slave Mode Control 1 = Enable Master Mode 0 = Enable Slave Mode

Table 16 Programming Master/Slave Modes

As a master mode device the WM8731/L controls the sequencing of data transfer (ADCDAT, DACDAT) and output of clocks (BCLK, ADCLRC, DACLRC) over the digital audio interface. It uses the timing generated from either its on-board crystal or the MCLK input as the reference for the clock and data transitions. This is illustrated in Figure 31. ADCDAT is always an output from and DACDAT is always an input to the WM8731/L independent of master or slave mode.

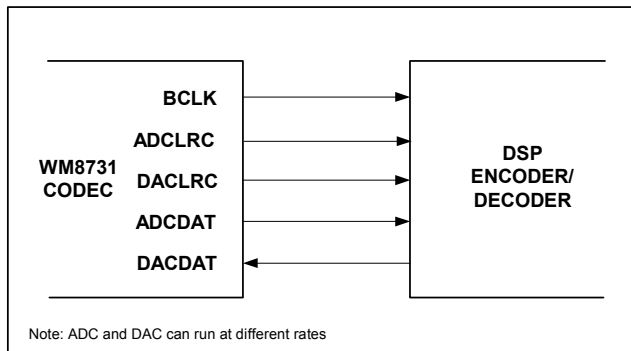

Figure 31 Master Mode

As a slave device the WM8731/L sequences the data transfer (ADCDAT, DACDAT) over the digital audio interface in response to the external applied clocks (BCLK, ADCLRC, DACLRC). This is illustrated in Figure 32.

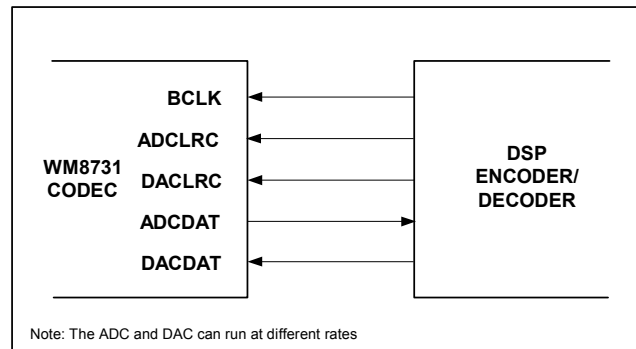

Figure 32 Slave Mode

Note that the WM8731/L relies on controlled phase relationships between audio interface BCLK, DACLRC and the master MCLK or CLKOUT. To avoid any timing hazards, refer to the timing section for detailed information.

AUDIO DATA SAMPLING RATES

The WM8731/L provides for two modes of operation (normal and USB) to generate the required DAC and ADC sampling rates. Normal and USB modes are programmed under software control according to the table below.

In Normal mode, the user controls the sample rate by using an appropriate MCLK or crystal frequency and the sample rate control register setting. The WM8731/L can support sample rates from 8ks/s up to 96ks/s.

In USB mode, the user must use a fixed MCLK or crystal frequency of 12MHz to generate sample rates from 8ks/s to 96ks/s. It is called USB mode since the common USB (Universal Serial Bus) clock is at 12MHz and the WM8731/L can be directly used within such systems. WM8731/L can generate all the normal audio sample rates from this one Master Clock frequency, removing the need for different master clocks or PLL circuits.

Uniquely, the WM8731/L offers the user the ability to sample the ADC and DAC at different rates under software control in both Normal and USB modes. This reduces the burden on any controlling DSP. However, the signal processing in the ADC and DAC over-sampling filters is tightly coupled together in order to minimise power consumption. To this end, only the combinations of sample rates listed in the following sections are supported. Note that these rates supported are anticipated to be the likely combinations used in typical audio systems.

REGISTER ADDRESS	BIT	LABEL	DEFAULT	DESCRIPTION		
0001000 Sampling Control	0	USB/ NORMAL	0	Mode Select 1 = USB mode (250/272fs) 0 = Normal mode (256/384fs)		
	1	BOSR	0	Base Over-Sampling Rate <table border="1" style="width: 100%;"> <tr> <td>USB Mode 0 = 250fs 1 = 272fs</td> <td>Normal Mode 96/88.2kHz 0 = 256fs 0 = 128fs 1 = 384fs 1 = 192fs</td> </tr> </table>	USB Mode 0 = 250fs 1 = 272fs	Normal Mode 96/88.2kHz 0 = 256fs 0 = 128fs 1 = 384fs 1 = 192fs
	USB Mode 0 = 250fs 1 = 272fs	Normal Mode 96/88.2kHz 0 = 256fs 0 = 128fs 1 = 384fs 1 = 192fs				
5:2	SR[3:0]	0000	ADC and DAC sample rate control; See USB Mode and Normal Mode Sample Rate sections for operation			

Table 17 Sample Rate Control

NORMAL MODE SAMPLE RATES

In normal mode MCLK/crystal oscillator is set up according to the desired sample rates of the ADC and DAC. For ADC or DAC sampling rates of 8, 32, 48 or 96kHz, MCLK frequencies of either 12.288MHz (256fs) or 18.432MHz (384fs) can be used. For ADC or DAC sampling rates of 8, 44.1 or 88.2kHz from MCLK frequencies of either 11.2896MHz (256fs) or 16.9344MHz (384fs) can be used.

Table 18 should be used to set up the device to work with the various sample rate combinations. For example if the user wishes to use the WM8731/L in normal mode with the ADC and DAC sample rates at 48kHz and 48kHz respectively then the device should be programmed with BOSR = 0, SR3 = 0, SR2 = 0, SR1 = 0 and SR0 = 0 with a 12.288MHz MCLK or with BOSR = 1, SR3 = 0, SR2 = 0, SR1 = 0 and SR0 = 0 with a 18.432MHz MCLK. The ADC and DAC will then operate with a Digital Filter of type 1, refer to Digital Filter Characteristics section for an explanation of the different filter types.

SAMPLING RATE		MCLK FREQUENCY	SAMPLE RATE REGISTER SETTINGS					DIGITAL FILTER TYPE
ADC	DAC		BOSR	SR3	SR2	SR1	SR0	
kHz	kHz	MHz						
48	48	12.288	0 (256fs)	0	0	0	0	1
		18.432	1 (384fs)	0	0	0	0	
48	8	12.288	0 (256fs)	0	0	0	1	1
		18.432	1 (384fs)	0	0	0	1	
8	48	12.288	0 (256fs)	0	0	1	0	1
		18.432	1 (384fs)	0	0	1	0	
8	8	12.288	0 (256fs)	0	0	1	1	1
		18.432	1 (384fs)	0	0	1	1	
32	32	12.288	0 (256fs)	0	1	1	0	1
		18.432	1 (384fs)	0	1	1	0	
96	96	12.288	0 (128fs)	0	1	1	1	2
		18.432	1 (192fs)	0	1	1	1	
44.1	44.1	11.2896	0 (256fs)	1	0	0	0	1
		16.9344	1 (384fs)	1	0	0	0	
44.1	8 (Note 1)	11.2896	0 (256fs)	1	0	0	1	1
		16.9344	1 (384fs)	1	0	0	1	
8 (Note 1)	44.1	11.2896	0 (256fs)	1	0	1	0	1
		16.9344	1 (384fs)	1	0	1	0	
8 (Note 1)	8 (Note 1)	11.2896	0 (256fs)	1	0	1	1	1
		16.9344	1 (384fs)	1	0	1	1	
88.2	88.2	11.2896	0 (128fs)	1	1	1	1	2
		16.9344	1 (192fs)	1	1	1	1	

Table 18 Normal Mode Sample Rate Look-up Table

Notes:

- 8k not exact, actual = 8.018kHz
- All other combinations of BOSR and SR[3:0] that are not in the truth table are invalid

The BOSR bit represents the base over-sampling rate. This is the rate that the WM8731/L digital signal processing is carried out at. In Normal mode, with BOSR = 0, the base over-sampling rate is at 256fs, with BOSR = 1, the base over-sampling rate is at 384fs. This can be used to determine the actual audio data rate produced by the ADC and required by the DAC.

Example scenarios are:

- with a requirement that the ADC data rate is 8kHz and DAC data rate is 48kHz, then choosing MCLK = 12.288MHz the device is programmed with BOSR = 0 (256fs), SR3 = 0, SR2 = 0, SR1 = 1, SR0 = 0. The ADC output data rate will then be exactly 8kHz (derived from 12.288MHz/256 x 1/6) and the DAC expects data at exactly 48kHz (derived from 12.288MHz/256)
- with a requirement that ADC data rate is 8kHz and DAC data rate is 44.1kHz, then choosing MCLK = 16.9344MHz the device is programmed with BOSR = 1 (384fs), SR3 = 1, SR2 = 0, SR1 = 1, SR0 = 0. The ADC will no longer output data at exactly 8.000kHz, instead it will be 8.018kHz (derived from 16.9344MHz/384 x 2/11), the DAC still is at exactly 44.1kHz (derived from 16.9344MHz/384). A slight (sub 0.5%) pitch shift will therefore result in the 8kHz audio data and (importantly) the user must ensure that the data across the digital interface is correctly synchronised at the 8.018kHz rate.

The exact sample rates achieved are defined by the relationships in Table 19 below.

TARGET SAMPLING RATE	ACTUAL SAMPLING RATE			
	BOSR=0		BOSR=1	
	MCLK=12.288	MCLK=11.2896	MCLK=18.432	MCLK=16.9344
kHz	kHz	kHz	kHz	kHz
8	8	8.018	8	8.018
	$(12.288\text{MHz}/256) \times 1/6$	$(11.2896\text{MHz}/256) \times 2/11$	$(18.432\text{MHz}/384) \times 1/6$	$(16.9344\text{MHz}/384) \times 2/11$
32	32	<i>not available</i>	32	<i>not available</i>
	$(12.288\text{MHz}/256) \times 2/3$		$(18.432\text{MHz}/384) \times 2/3$	
44.1	<i>not available</i>	44.1	<i>not available</i>	44.1
		$11.2896\text{MHz}/256$		$16.9344\text{MHz}/384$
48	48	<i>not available</i>	48	<i>not available</i>
	$12.288\text{MHz}/256$		$18.432\text{MHz}/384$	
88.2	<i>not available</i>	88.2	<i>not available</i>	88.2
		$(11.2896\text{MHz}/256) \times 2$		$(16.9344\text{MHz}/384) \times 2$
96	96	<i>not available</i>	96	<i>not available</i>
	$(12.288\text{MHz}/256) \times 2$		$(18.432\text{MHz}/384) \times 2$	

Table 19 Normal Mode Actual Sample Rates

128/192fs NORMAL MODE

The Normal Mode sample rates are designed for standard 256fs and 384fs MCLK rates. However the WM8731/L is also capable of being clocked from a 128 or 192fs MCLK for application over limited sampling rates as shown in the table below.

SAMPLING RATE		MCLK FREQUENCY	SAMPLE RATE REGISTER SETTINGS					DIGITAL FILTER TYPE
ADC	DAC		BOSR	SR3	SR2	SR1	SR0	
kHz	kHz	MHz						
48	48	6.144	0	0	1	1	1	2
		9.216	1	0	1	1	1	
44.1	44.1	5.6448	0	1	1	1	1	2
		8.4672	1	1	1	1	1	

Table 20 128fs Normal Mode Sample Rate Look-up Table

512/768fs NORMAL MODE

512 fs and 768 fs MCLK rates can be accommodated by using the CLKIDIV2 bit (Register 8, bit 6). The core clock to the DSP will be divided by 2 so an external 512/768 fs MCLK will become 256/384 fs internally and the device otherwise operates as in Table 18 but with MCLK at twice the specified rate. See Table 17 for software control.

USB MODE SAMPLE RATES

In USB mode the MCLK/crystal oscillator input is 12MHz only.

SAMPLING RATE		MCLK FREQUENCY	SAMPLE RATE REGISTER SETTINGS					DIGITAL FILTER TYPE
ADC	DAC		BOSR	SR3	SR2	SR1	SR0	
kHz	kHz	MHz						
48	48	12.000	0	0	0	0	0	0
44.1 (Note 2)	44.1 (Note 2)	12.000	1	1	0	0	0	1
48	8	12.000	0	0	0	0	1	0
44.1 (Note 2)	8 (Note 1)	12.000	1	1	0	0	1	1
8	48	12.000	0	0	0	1	0	0
8 (Note 1)	44.1 (Note 2)	12.000	1	1	0	1	0	1
8	8	12.000	0	0	0	1	1	0
8 (Note 1)	8 (Note 1)	12.000	1	1	0	1	1	1
32	32	12.000	0	0	1	1	0	0
96	96	12.000	0	0	1	1	1	3
88.2 (Note 3)	88.2 (Note 3)	12.000	1	1	1	1	1	2

Table 21 USB Mode Sample Rate Look-up Table

Notes:

1. 8k not exact, actual = 8.021kHz
2. 44.1k not exact, actual = 44.118kHz
3. 88.2k not exact, actual = 88.235kHz
4. All other combinations of BOSR and SR[3:0] that are not in the truth table are invalid

The table above can be used to set up the device to work with various sample rate combinations. For example if the user wishes to use the WM8731/L in USB mode with the ADC and DAC sample rates at 48kHz and 48kHz respectively then the device should be programmed with BOSR = 0, SR3 = 0, SR2 = 0, SR1 = 0 and SR0 = 0. The ADC and DAC will then operate with a Digital Filter of type 0, refer to Digital Filter Characteristics section for an explanation of the different filter types.

The BOSR bit represents the base over-sampling rate. This is the rate that the WM8731/L digital signal processing is carried out at and the sampling rate will always be a sub-multiple of this. In USB mode, with BOSR = 0, the base over-sampling rate is defined at 250fs, with BOSR = 1, the base over-sampling rate is defined at 272fs. This can be used to determine the actual audio sampling rate produced by the ADC and required by the DAC.

Example scenarios are, :-

1. with a requirement that the ADC data sampling rate is 8kHz and DAC data sampling rate is 48kHz the device is programmed with BOSR = 0 (250fs), SR3 = 0, SR2 = 0, SR1 = 1, SR0 = 0. The ADC will then be exactly 8kHz (derived from $12\text{MHz}/250 \times 1/6$) and the DAC expects data at exactly 48kHz (derived from $12\text{MHz}/250$).
2. with a requirement that ADC data rate is 8kHz and DAC data rate is 44.1kHz the device is programmed with BOSR = 1 (272fs), SR3 = 1, SR2 = 0, SR1 = 1, SR0 = 0. The ADC will not output data at exactly 8kHz, instead it will be 8.021kHz (derived from $12\text{MHz}/272 \times 2/11$) and the DAC at 44.118kHz (derived from $12\text{MHz}/272$). A slight (sub 0.5%) pitch shift will therefore result in the 8kHz and 44.1kHz audio data and (more importantly) the user must ensure that the data across the digital interface is correctly synchronised at the 8.021kHz and 44.117kHz rates.

The exact sample rates supported for all combinations are defined by the relationships in Table 22 below.

TARGET SAMPLING RATE	ACTUAL SAMPLING RATE	
	BOSR=0 (250fs)	BOSR=1 (272fs)
kHz	kHz	kHz
8	8	8.021
	12MHz/(250 x 48/8)	12MHz/(272 x 11/2)
32	32	<i>not available</i>
	12MHz/(250 x 48/32)	
44.1	<i>not available</i>	44.117
		12MHz/272
48	48	<i>not available</i>
	12MHz/250	
88.2	<i>not available</i>	88.235
		12MHz/136
96	96	<i>not available</i>
	12MHz/125	

Table 22 USB Mode Actual Sample Rates

ACTIVATING DSP AND DIGITAL AUDIO INTERFACE

To prevent any communication problems from arising across the Digital Audio Interface the Audio Interface is disabled (tristate with weak 100k pulldown). Once the Audio Interface and the Sampling Control has been programmed it is activated by setting the ACTIVE bit under Software Control.

REGISTER ADDRESS	BIT	LABEL	DEFAULT	DESCRIPTION
0001001 Active Control	0	ACTIVE	0	Activate Interface 1 = Active 0 = Inactive

Table 23 Activating DSP and Digital Audio Interface

It is recommended that between changing any content of Digital Audio Interface or Sampling Control Register that the active bit is reset then set.

SOFTWARE CONTROL INTERFACE

The software control interface may be operated using either a 3-wire (SPI-compatible) or 2-wire MPU interface. Selection of interface format is achieved by setting the state of the MODE pin.

In 3-wire mode, SDIN is used for the program data, SCLK is used to clock in the program data and CSB is used to latch in the program data. In 2-wire mode, SDIN is used for serial data and SCLK is used for the serial clock. In 2-wire mode, the state of CSB pin allows the user to select one of two addresses.

SELECTION OF SERIAL CONTROL MODE

The serial control interface may be selected to operate in either 2 or 3-wire modes. This is achieved by setting the state of the MODE pin.

MODE	INTERFACE FORMAT
0	2 wire
1	3 wire

Table 24 Control Interface Mode Selection

3-WIRE (SPI COMPATIBLE) SERIAL CONTROL MODE

The WM8731/L can be controlled using a 3-wire serial interface. SDIN is used for the program data, SCLK is used to clock in the program data and CSB is use to latch in the program data. The 3-wire interface protocol is shown in Figure 33.

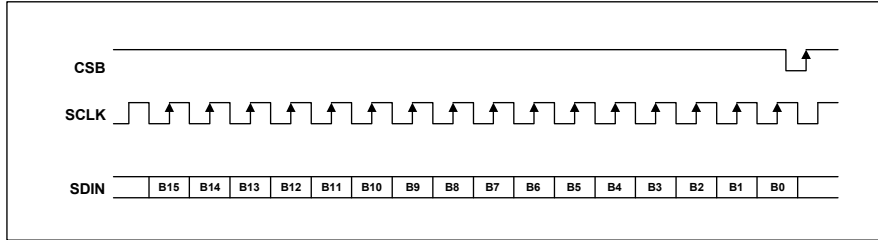

Figure 33 3-Wire Serial Interface

Notes:

1. B[15:9] are Control Address Bits
2. B[8:0] are Control Data Bits
3. CSB is edge sensitive not level sensitive. The data is latched on the rising edge of CSB.

2-WIRE SERIAL CONTROL MODE

The WM8731/L supports a 2-wire MPU serial interface. The device operates as a slave device only. The WM8731/L has one of two slave addresses that are selected by setting the state of pin 15, (CSB).

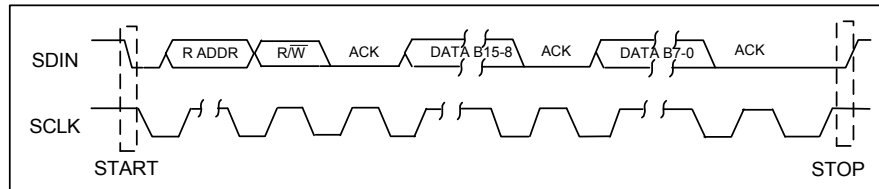

Figure 34 2-Wire Serial Interface

Notes:

1. B[15:9] are Control Address Bits
2. B[8:0] are Control Data Bits

CSB STATE	ADDRESS
0	0011010
1	0011011

Table 25 2-Wire MPU Interface Address Selection

To control the WM8731/L on the 2-wire bus the master control device must initiate a data transfer by establishing a start condition, defined by a high to low transition on SDIN while SCLK remains high. This indicates that an address and data transfer will follow. All peripherals on the 2-wire bus respond to the start condition and shift in the next eight bits (7-bit address + R/W bit). The transfer is MSB first. The 7-bit address consists of a 6-bit base address + a single programmable bit to select one of two available addresses for this device (see Table 24). If the correct address is received and the R/W bit is '0', indicating a write, then the WM8731/L will respond by pulling SDIN low on the next clock pulse (ACK). The WM8731/L is a write only device and will only respond to the R/W bit indicating a write. If the address is not recognised the device will return to the idle condition and wait for a new start condition and valid address.

Once the WM8731/L has acknowledged a correct address, the controller will send eight data bits (bits B15-B8). WM8731/L will then acknowledge the sent data by pulling SDIN low for one clock pulse. The controller will then send the remaining eight data bits (bits B7-B0) and the WM8731/L will then acknowledge again by pulling SDIN low.

A stop condition is defined when there is a low to high transition on SDIN while SCLK is high. If a start or stop condition is detected out of sequence at any point in the data transfer then the device will jump to the idle condition.

After receiving a complete address and data sequence the WM8731/L returns to the idle state and waits for another start condition. Each write to a register requires the complete sequence of start condition, device address and R/W bit followed by the 16 register address and data bits.

POWER DOWN MODES

The WM8731/L contains power conservation modes in which various circuit blocks may be safely powered down in order to conserve power. This is software programmable as shown in the table below.

REGISTER ADDRESS	BIT	LABEL	DEFAULT	DESCRIPTION
0000110 Power Down Control	0	LINEINPD	1	Line Input Power Down 1 = Enable Power Down 0 = Disable Power Down
	1	MICPD	1	Microphone Input an Bias Power Down 1 = Enable Power Down 0 = Disable Power Down
	2	ADCPD	1	ADC Power Down 1 = Enable Power Down 0 = Disable Power Down
	3	DACPD	1	DAC Power Down 1 = Enable Power Down 0 = Disable Power Down
	4	OUTPD	1	Line Output Power Down 1 = Enable Power Down 0 = Disable Power Down
	5	OSCPD	0	Oscillator Power Down 1 = Enable Power Down 0 = Disable Power Down
	6	CLKOUTPD	0	CLKOUT power down 1 = Enable Power Down 0 = Disable Power Down
	7	POWEROFF	1	Power Off Device 1 = Device Power Off 0 = Device Power On

Table 26 Power Conservation Modes Software Control

The power down control can be used to either a) permanently disable functions when not required in certain applications or b) to dynamically power up and down functions depending on the operating mode, e.g.: during playback or record. Please follow the special instructions below if dynamic implementations are being used.

LINEINPD: Simultaneously powers down both the Line Inputs. This can be done dynamically without any audible effects either on the ADC or to the Line Outputs in Bypass mode. This is of use when the device enters Playback, Pause or Stop modes or the Microphone input has been selected.

MICPD: Simultaneously powers down both the Microphone Input and Microphone Bias. If this is done dynamically, audible pops through the ADC will result. This will only be audible if the Microphone Input is selected to the ADC at the time. If the state of MICPD is changed then the controlling DSP or microprocessor should switch to select the Line Inputs as input to the ADC (INSEL) before changing MICPD. This is of use when the device enters Playback, Pause or Stop modes or the Microphone Input is not selected.

ADCPD: Powers down the ADC and ADC Filters. If this is done dynamically then audible pops will result if any signals were present through the ADC. To overcome this whenever the ADC is to be powered down, either mute the Microphone Input (MUTEIN) or MUTELINEIN, then change ADCPD. This is of use when the device enters Playback, Pause or Stop modes regardless of whether Microphone or Line Inputs are selected.

DACPD: Powers down the DAC and DAC Digital Filters. If this is done dynamically then audible pops will result unless the following guidelines are followed. In order to prevent pops, the DAC should first be soft-muted (DACMU), the output should then be de-selected from the line and headphone output (DACSEL), then the DAC powered down (DACPD). This is of use when the device enters Record, Pause, Stop or Bypass modes.

OUTPD: Powers down the Line and Headphone outputs. If this is done dynamically then audible pops may result unless the DAC is first soft-muted (DACMU). This is of use when the device enters Record, Pause or Stop modes.

OSCPD: Powers off the on board crystal oscillator. The MCLK input will function independently of the Oscillator being powered down.

CLKOUTPD: Powers down the CLOCKOUT pin. This conserves power, reduces digital noise and RF emissions if not required. CLKOUT is tied low when powered down.

The device can be put into a standby mode (STANDBY) by powering down all the audio circuitry under software control as shown in Table 27. If the crystal oscillator and/or CLOKOUT pins are being used to derive the system master clock, these should probably never be powered off in standby. Provision has been made to independently power off these areas according to Table 27.

POWER OFF	CLKOUTPD	OSCPD	OUTPD	DACPD	ADCPD	MICPD	LINEINPD	DESCRIPTION
0	0	0	1	1	1	1	1	STANDBY, but with Crystal Oscillator OS and CLKOUT available
0	1	0	1	1	1	1	1	STANDBY, but with Crystal Oscillator OS available, CLKOUT not-available
0	1	1	1	1	1	1	1	STANDBY, Crystal oscillator and CLKOUT not-available.

Table 27 Standby Mode

In STANDBY mode the Control Interface, a small portion of the digital and areas of the analogue circuitry remain active. The active analogue includes the analogue VMID reference so that the analogue line inputs, line outputs and headphone outputs remain biased to VMID. This reduces any audible effects caused by DC glitches when entering or leaving STANDBY mode.

The device can be powered off by writing to the POWEROFF bit of the Power Down register. In POWEROFF mode the Control Interface and a small portion of the digital remain active. The analogue VMID reference is disabled. As in STANDBY mode the crystal oscillator and/or CLKOUT pin can be independently controlled. Refer to Table 28.

POWER OFF	CLKOUTPD	OSCPD	OUTPD	DACPD	ADCPD	MICPD	LINEINPD	DESCRIPTION
1	0	0	X	X	X	X	X	POWEROFF, but with Crystal Oscillator OS and CLKOUT available
1	1	0	X	X	X	X	X	POWEROFF, but with Crystal Oscillator OS available, CLKOUT not-available
1	1	1	X	X	X	X	X	POWEROFF, Crystal oscillator and CLKOUT not-available.

Table 28 Poweroff Mode

REGISTER MAP

The complete register map is shown in Table 29. The detailed description can be found in Table 30 and in the relevant text of the device description. There are 11 registers with 16 bits per register (7 bit address + 9 bits of data). These can be controlled using either the 2 wire or 3 wire MPU interface.

REGISTER	BIT[8]	BIT[7]	BIT[6]	BIT[5]	BIT[4]	BIT[3]	BIT[2]	BIT[1]	BIT[0]	DEFAULT
R0 (00h) Left Line In	LRINBOTH	LINMUTE	0	0	LINVOL[4:0]					0_1001_0111
R1 (01h) Right Line In	RLINBOTH	RINMUTE	0	0	RINVOL[4:0]					0_1001_0111
R2 (02h) Left Headphone Out	LRHPBOTH	LZCEN	LHPVOL[6:0]							0_0111_1001
R1 (01h) Right Headphone Out	RLHPBOTH	RZCEN	RHPVOL[6:0]							0_0111_1001
R4 (04h) Analogue Audio Path Control	0	SIDEATT[1:0]		SIDETONE	DACSEL	BYPASS	INSEL	MUTEMIC	MICBOOST	0_0000_1010
R5 (05h) Digital Audio Path Control	0	0	0	0	HPOR	DACMU	DEEMPH[1:0]		ADCHPD	0_0000_1000
R6 (06h) Power Down Control	0	POWEROFF	CLKOUTPD	OSCPD	OUTPD	DACPD	ADCPD	MICPD	LINEINPD	0_1001_1111
R7 (07h) Digital Audio Interface Format	0	BCLKINV	MS	LRSWAP	LRP	IWL[1:0]		FORMAT[1:0]		0_1001_1111
R8 (08h) Sampling Control	0	CLKODIV2	CLKIDIV2	SR[3:0]				BOSR	USB/ NORMAL	0_0000_0000
R9 (09h) Active Control	0	0	0	0	0	0	0	0	Active	0_0000_0000
R15 (0Fh) Reset	RESET[8:0]									not reset

Table 29 Register Map

REGISTER ADDRESS	BIT	LABEL	DEFAULT	DESCRIPTION
0000000 Left Line In	4:0	LINVOL[4:0]	10111 (0dB)	Left Channel Line Input Volume Control 11111 = +12dB . . 1.5dB steps down to 00000 = -34.5dB
	7	LINMUTE	1	Left Channel Line Input Mute to ADC 1 = Enable Mute 0 = Disable Mute
	8	LRINBOTH	0	Left to Right Channel Line Input Volume and Mute Data Load Control 1 = Enable Simultaneous Load of LINVOL[4:0] and LINMUTE to RINVOL[4:0] and RINMUTE 0 = Disable Simultaneous Load
0000001 Right Line In	4:0	RINVOL[4:0]	10111 (0dB)	Right Channel Line Input Volume Control 11111 = +12dB . . 1.5dB steps down to 00000 = -34.5dB
	7	RINMUTE	1	Right Channel Line Input Mute to ADC 1 = Enable Mute 0 = Disable Mute
	8	RLINBOTH	0	Right to Left Channel Line Input Volume and Mute Data Load Control 1 = Enable Simultaneous Load of RINVOL[4:0] and RINMUTE to LINVOL[4:0] and LINMUTE 0 = Disable Simultaneous Load
0000010 Left Headphone Out	6:0	LHPVOL [6:0]	1111001 (0dB)	Left Channel Headphone Output Volume Control 1111111 = +6dB . . 1dB steps down to 0110000 = -73dB 0000000 to 0101111 = MUTE
	7	LZCEN	0	Left Channel Zero Cross detect Enable 1 = Enable 0 = Disable
	8	LRHPBOTH	0	Left to Right Channel Headphone Volume, Mute and Zero Cross Data Load Control 1 = Enable Simultaneous Load of LHPVOL[6:0] and LZCEN to RHPVOL[6:0] and RZCEN 0 = Disable Simultaneous Load

REGISTER ADDRESS	BIT	LABEL	DEFAULT	DESCRIPTION
000011 Right Headphone Out	6:0	RHPVOL [6:0]	1111001 (0dB)	Right Channel Headphone Output Volume Control 1111111 = +6dB . . 1dB steps down to 0110000 = -73dB 0000000 to 0101111 = MUTE
	7	RZCEN	0	Right Channel Zero Cross detect Enable 1 = Enable 0 = Disable
	8	RLHPBOTH	0	Right to Left Channel Headphone Volume, Mute and Zero Cross Data Load Control 1 = Enable Simultaneous Load of RHPVOL[6:0] and RZCEN to LHPVOL[6:0] and LZCEN 0 = Disable Simultaneous Load
0000100 Analogue Audio Path Control	0	MICBOOST	0	Microphone Input Level Boost 1 = Enable Boost 0 = Disable Boost
	1	MUTEMIC	1	Mic Input Mute to ADC 1 = Enable Mute 0 = Disable Mute
	2	INSEL	0	Microphone/Line Input Select to ADC 1 = Microphone Input Select to ADC 0 = Line Input Select to ADC
	3	BYPASS	1	Bypass Switch 1 = Enable Bypass 0 = Disable Bypass
	4	DACSEL	0	DAC Select 1 = Select DAC 0 = Don't select DAC
	5	SIDETONE	0	Side Tone Switch 1 = Enable Side Tone 0 = Disable Side Tone
	7:6	SIDEATT[1:0]	00	Side Tone Attenuation 11 = -15dB 10 = -12dB 01 = -9dB 00 = -6dB

REGISTER ADDRESS	BIT	LABEL	DEFAULT	DESCRIPTION
0000101 Digital Audio Path Control	0	ADCHPD	0	ADC High Pass Filter Enable 1 = Disable High Pass Filter 0 = Enable High Pass Filter
	2:1	DEEMP[1:0]	00	De-emphasis Control 11 = 48kHz 10 = 44.1kHz 01 = 32kHz 00 = Disable
	3	DACMU	1	DAC Soft Mute Control 1 = Enable soft mute 0 = Disable soft mute
	4	HPOR	0	Store dc offset when High Pass Filter disabled 1 = store offset 0 = clear offset
0000110 Power Down Control	0	LINEINPD	1	Line Input Power Down 1 = Enable Power Down 0 = Disable Power Down
	1	MICPD	1	Microphone Input an Bias Power Down 1 = Enable Power Down 0 = Disable Power Down
	2	ADCPD	1	ADC Power Down 1 = Enable Power Down 0 = Disable Power Down
	3	DACPD	1	DAC Power Down 1 = Enable Power Down 0 = Disable Power Down
	4	OUTPD	1	Outputs Power Down 1 = Enable Power Down 0 = Disable Power Down
	5	OSCPD	0	Oscillator Power Down 1 = Enable Power Down 0 = Disable Power Down
	6	CLKOUTPD	0	CLKOUT power down 1 = Enable Power Down 0 = Disable Power Down
	7	POWEROFF	1	POWEROFF mode 1 = Enable POWEROFF 0 = Disable POWEROFF

REGISTER ADDRESS	BIT	LABEL	DEFAULT	DESCRIPTION
0000111 Digital Audio Interface Format	1:0	FORMAT[1:0]	10	Audio Data Format Select 11 = DSP Mode, frame sync + 2 data packed words 10 = I ² S Format, MSB-First left-1 justified 01 = MSB-First, left justified 00 = MSB-First, right justified
	3:2	IWL[1:0]	10	Input Audio Data Bit Length Select 11 = 32 bits 10 = 24 bits 01 = 20 bits 00 = 16 bits
	4	LRP	0	DACLRC phase control (in left, right or I ² S modes) 1 = Right Channel DAC data when DACLRC high 0 = Right Channel DAC data when DACLRC low (opposite phasing in I ² S mode) or DSP mode A/B select (in DSP mode only) 1 = MSB is available on 2nd BCLK rising edge after DACLRC rising edge 0 = MSB is available on 1st BCLK rising edge after DACLRC rising edge
	5	LRSWAP	0	DAC Left Right Clock Swap 1 = Right Channel DAC Data Left 0 = Right Channel DAC Data Right
	6	MS	0	Master Slave Mode Control 1 = Enable Master Mode 0 = Enable Slave Mode
	7	BCLKINV	0	Bit Clock Invert 1 = Invert BCLK 0 = Don't invert BCLK
	0001000 Sampling Control	0	USB/ NORMAL	0
1		BOSR	0	Base Over-Sampling Rate USB Mode 0 = 250fs 1 = 272fs Normal Mode 0 = 256fs 1 = 384fs
5:2		SR[3:0]	0000	ADC and DAC sample rate control; See USB Mode and Normal Mode Sample Rate sections for operation
6		CLKIDIV2	0	Core Clock divider select 1 = Core Clock is MCLK divided by 2 0 = Core Clock is MCLK
7		CLKODIV2	0	CLKOUT divider select 1 = CLOCKOUT is Core Clock divided by 2 0 = CLOCKOUT is Core Clock

REGISTER ADDRESS	BIT	LABEL	DEFAULT	DESCRIPTION
0001001 Active Control	0	ACTIVE	0	Activate Interface 1 = Active 0 = Inactive
0001111 Reset Register	8:0	RESET	not reset	Reset Register Writing 00000000 to register resets device

Table 30 Register Map Description

DIGITAL FILTER CHARACTERISTICS

The ADC and DAC employ different digital filters. There are 4 types of digital filter, called Type 0, 1, 2 and 3. The performance of Types 0 and 1 is listed in the table below, the responses of all filters is shown in the preceding pages.

PARAMETER	TEST CONDITIONS	MIN	TYP	MAX	UNIT
ADC Filter Type 0 (USB Mode, 250fs operation)					
Passband	+/- 0.05dB	0		0.416fs	
	-6dB		0.5fs		
Passband Ripple				+/- 0.05	dB
Stopband		0.584fs			
Stopband Attenuation	f > 0.584fs	-60			dB
ADC Filter Type 1 (USB mode, 272fs or Normal mode operation)					
Passband	+/- 0.05dB	0		0.4535fs	
	-6dB		0.5fs		
Passband Ripple				+/- 0.05	dB
Stopband		0.5465fs			
Stopband Attenuation	f > 0.5465fs	-60			dB
High Pass Filter Corner Frequency	-3dB		3.7		Hz
	-0.5dB		10.4		
	-0.1dB		21.6		
DAC Filter Type 0 (USB mode, 250fs operation)					
Passband	+/- 0.03dB	0		0.416fs	
	-6dB		0.5fs		
Passband Ripple				+/-0.03	dB
Stopband		0.584fs			
Stopband Attenuation	f > 0.584fs	-50			dB
DAC Filter Type 1 (USB mode, 272fs or Normal mode operation)					
Passband	+/- 0.03dB	0		0.4535fs	
	-6dB		0.5fs		
Passband Ripple				+/- 0.03	dB
Stopband		0.5465fs			
Stopband Attenuation	f > 0.5465fs	-50			dB

Table 31 Digital Filter Characteristics

DAC FILTERS		ADC FILTERS	
Mode	Group Delay	Mode	Group Delay
0	11/FS	0	12/FS
1	18/FS	1	20/FS
2	5/FS	2	3/FS
3	5/FS	3	6/FS

Table 32 ADC/DAC Digital Filters Group Delay

TERMINOLOGY

1. Stop Band Attenuation (dB) - the degree to which the frequency spectrum is attenuated (outside audio band)
2. Pass-band Ripple – any variation of the frequency response in the pass-band region

DAC FILTER RESPONSES

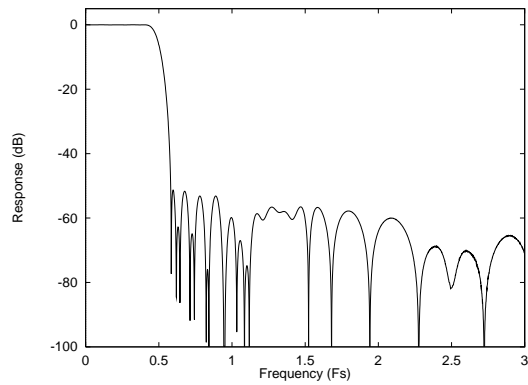

Figure 35 DAC Digital Filter Frequency Response –Type 0

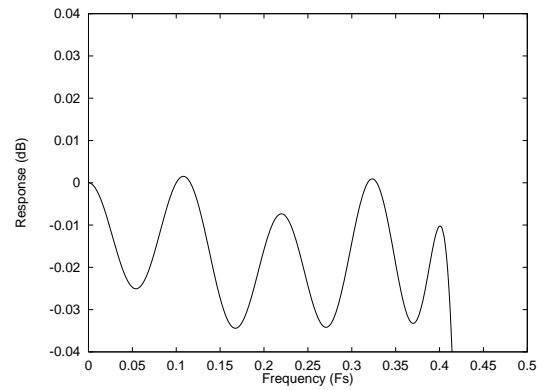

Figure 36 DAC Digital Filter Ripple –Type 0

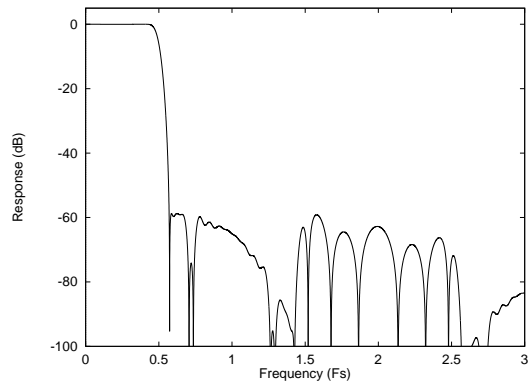

Figure 37 DAC Digital Filter Frequency Response –Type 1

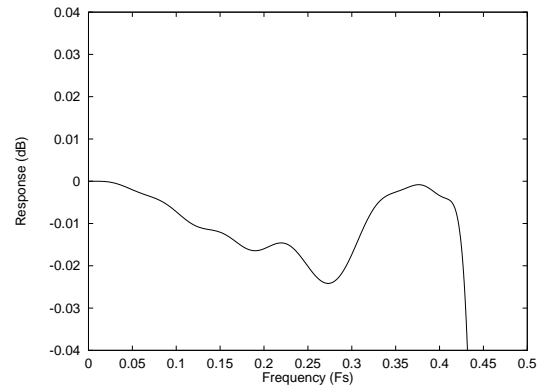

Figure 38 DAC Digital Filter Ripple –Type 1

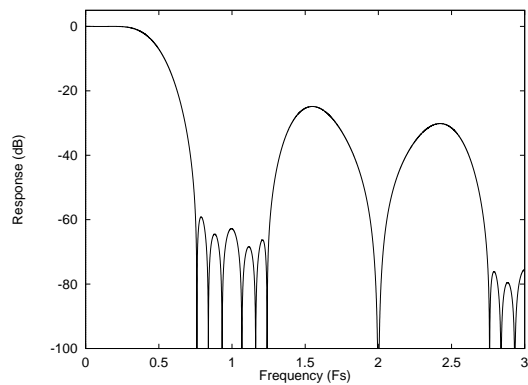

Figure 39 DAC Digital Filter Frequency Response –Type 2

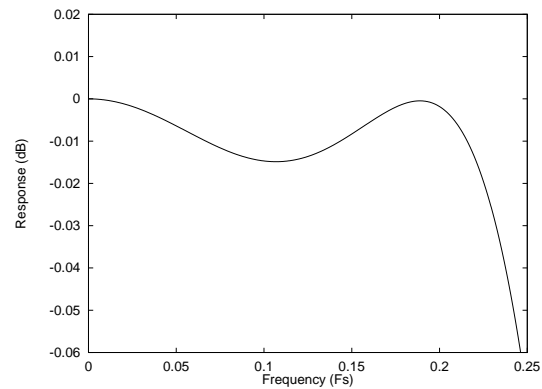

Figure 40 DAC Digital Filter Ripple –Type 2

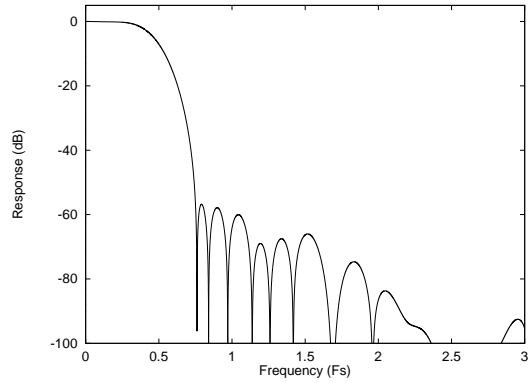

Figure 41 DAC Digital Filter Frequency Response –Type 3

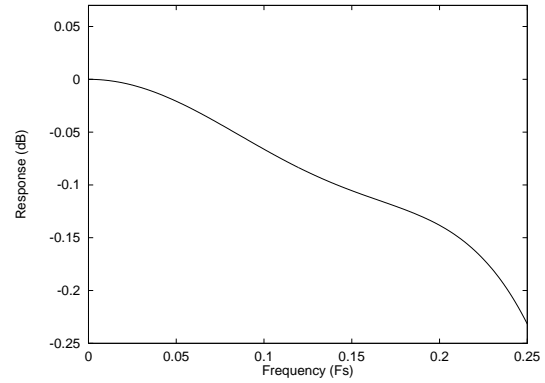

Figure 42 DAC Digital Filter Ripple –Type 3

ADC FILTER RESPONSES

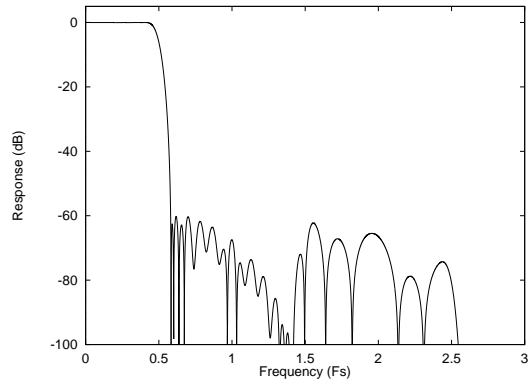

Figure 43 ADC Digital Filter Frequency Response –Type 0

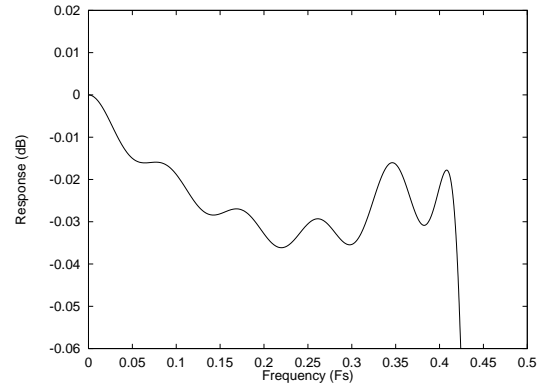

Figure 44 ADC Digital Filter Ripple –Type 0

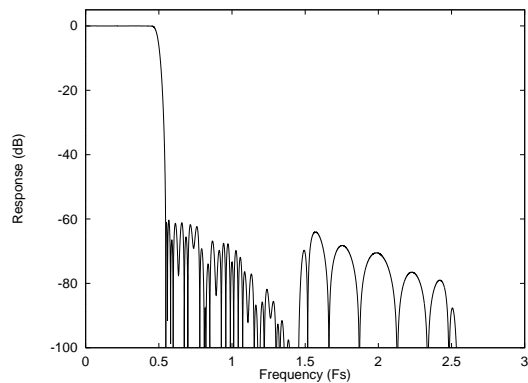

Figure 45 ADC Digital Filter Frequency Response –Type 1

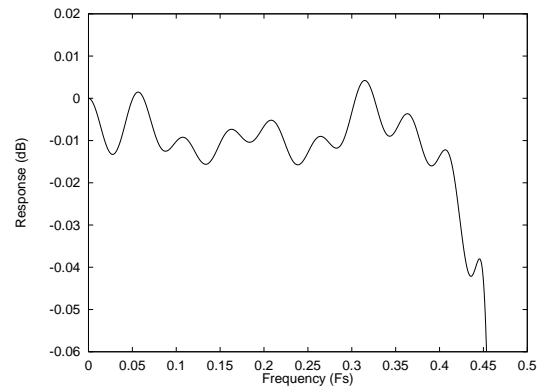

Figure 46 ADC Digital Filter Ripple –Type 1

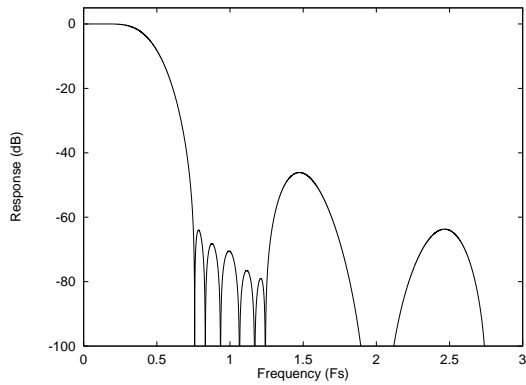

Figure 47 ADC Digital Filter Frequency Response –Type 2

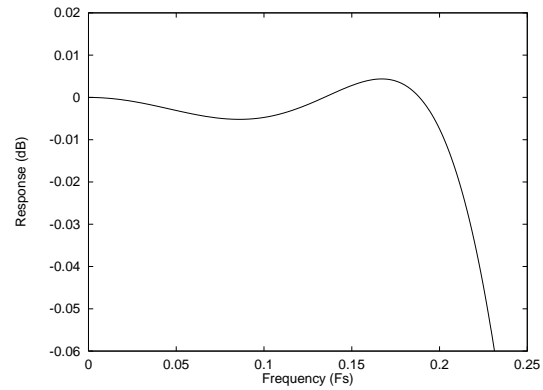

Figure 48 ADC Digital Filter Ripple –Type 2

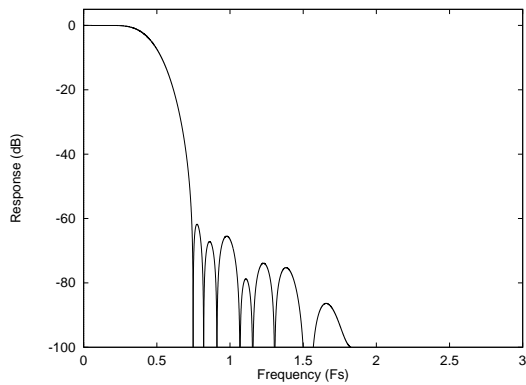

Figure 49 ADC Digital Filter Frequency Response –Type 3

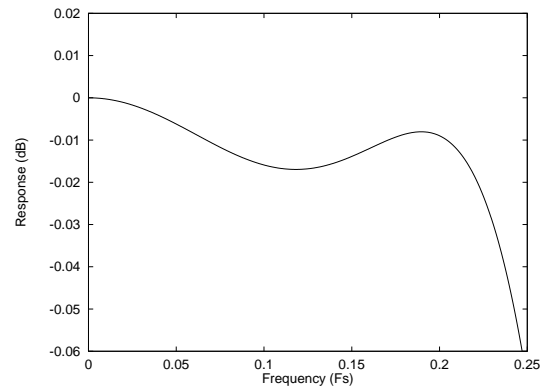

Figure 50 ADC Digital Filter Ripple –Type 3

ADC HIGH PASS FILTER

The WM8731/L has a selectable digital high pass filter to remove DC offsets. The filter response is characterised by the following polynomial.

$$H(z) = \frac{1 - z^{-1}}{1 - 0.9995 z^{-1}}$$

DIGITAL DE-EMPHASIS CHARACTERISTICS

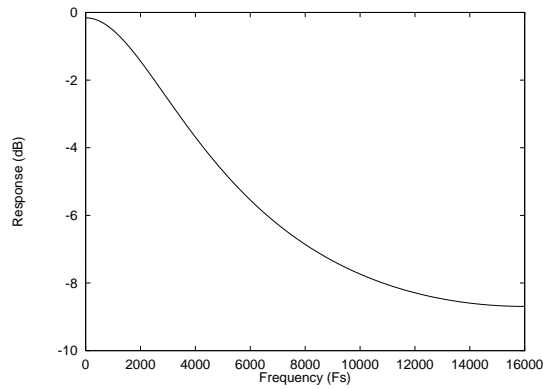

Figure 51 De-Emphasis Frequency Response (32kHz)

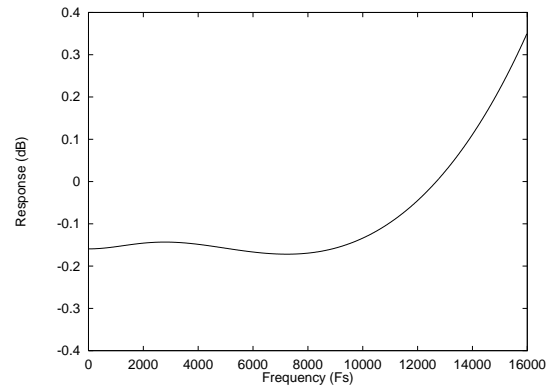

Figure 52 De-Emphasis Error (32kHz)

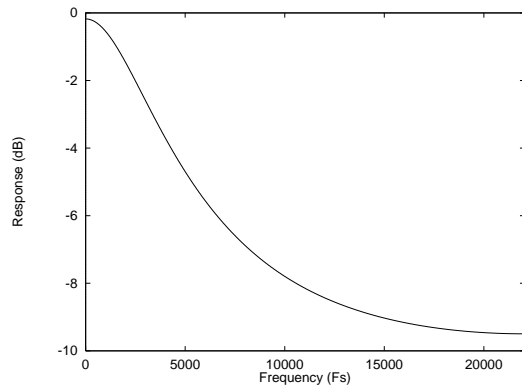

Figure 53 De-Emphasis Frequency Response (44.1kHz)

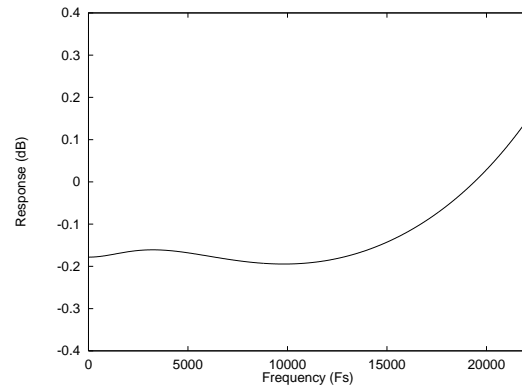

Figure 54 De-Emphasis Error (44.1kHz)

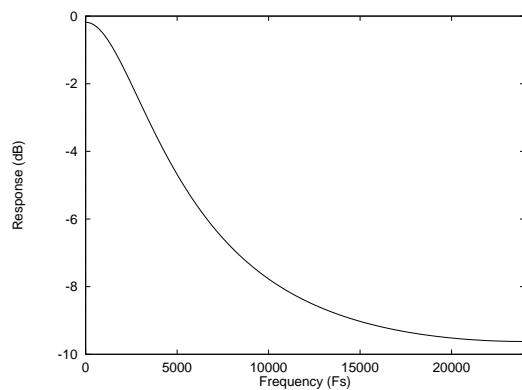

Figure 55 De-Emphasis Frequency Response (48kHz)

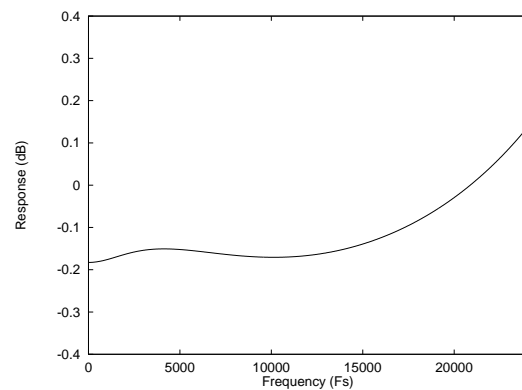
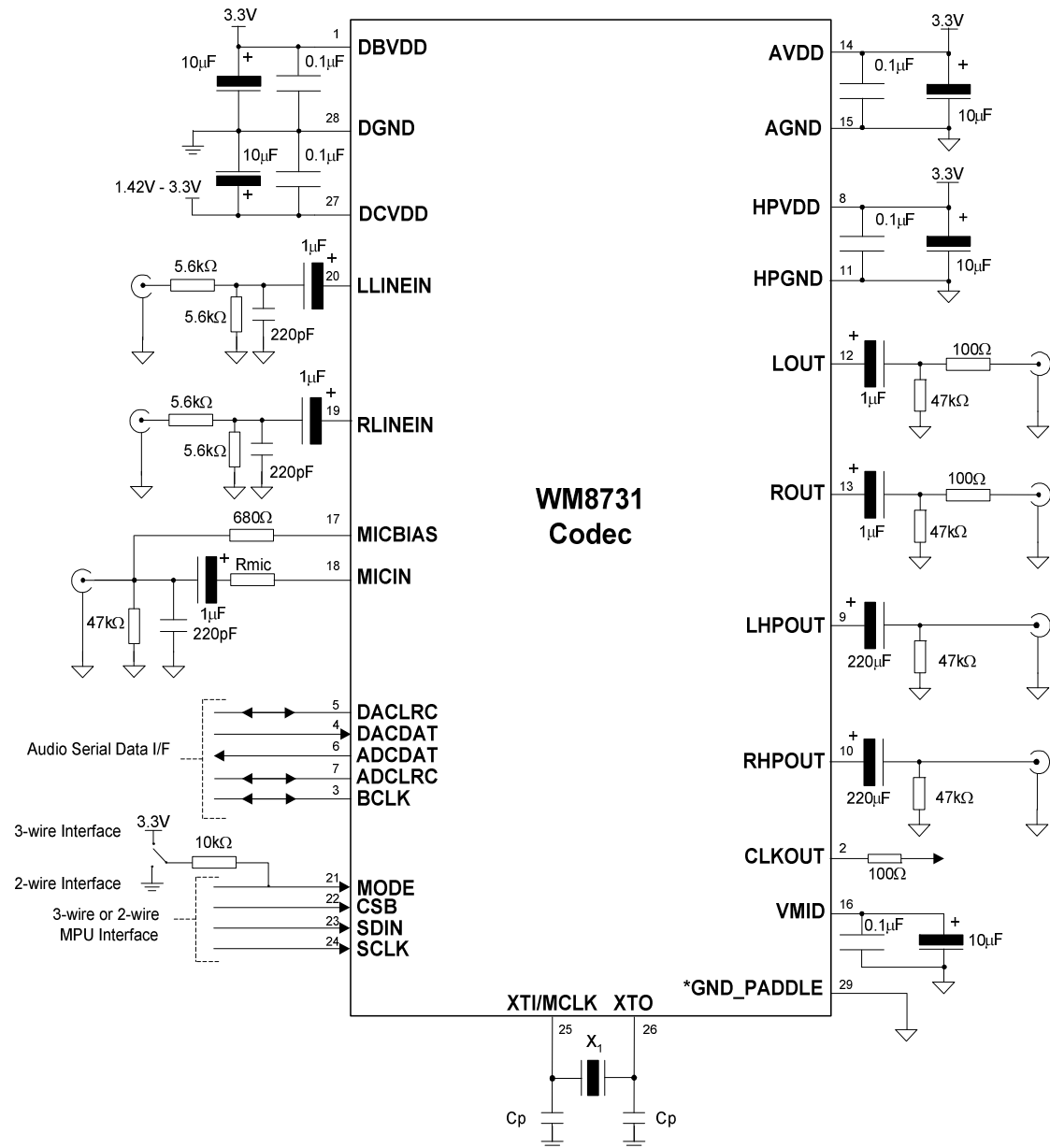

Figure 56 De-Emphasis Error (48kHz)

APPLICATIONS INFORMATION

RECOMMENDED EXTERNAL COMPONENTS



- Note:
1. R_{mic} - The value of this resistor is dependent on the gain setting. Refer to Page 20 for R_{mic} calculation.
 2. Where possible, it is recommended that NPO or COG type capacitors should be used for best performance.
 3. *Ground paddle on QFN package only should be attached to AGND.

Figure 57 External Components Diagram

MINIMISING POP NOISE AT THE ANALOGUE OUTPUTS

To minimise any pop or click noise when the system is powered up or down, the following procedures are recommended.

POWER UP SEQUENCE

- Switch on power supplies. By default the WM8731 is in Standby Mode, the DAC is digitally muted and the Audio Interface and Outputs are all OFF.
- Set all required bits in the Power Down register (0Ch) to '0'; EXCEPT the OUTPD bit, this should be set to '1' (Default).
- Set required values in all other registers except 12h (Active).
- Set the 'Active' bit in register 12h.
- The last write of the sequence should be setting OUTPD to '0' (active) in register 0Ch, enabling the DAC signal path, free of any significant power-up noise.

POWER DOWN SEQUENCE

- Set the OUTPD bit to '1' (power down).
- Remove the WM8731 supplies.

PACKAGE DIMENSIONS - SSOP

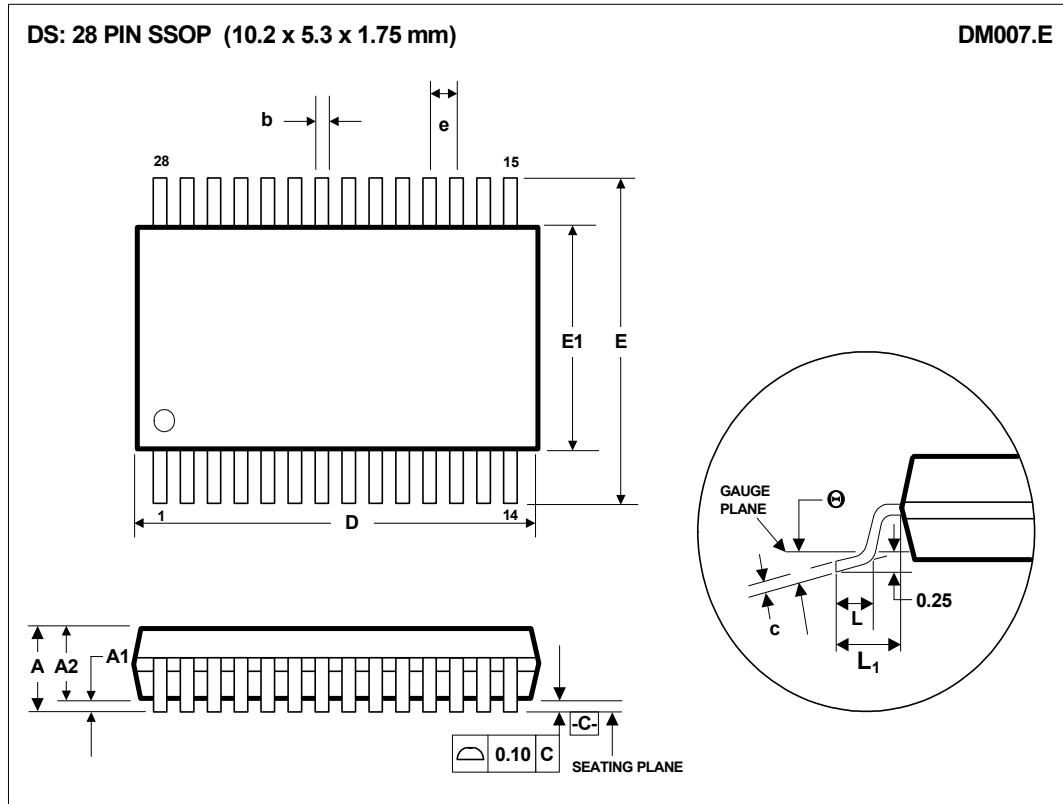

Symbols	Dimensions (mm)		
	MIN	NOM	MAX
A	----	----	2.0
A₁	0.05	----	0.25
A₂	1.65	1.75	1.85
b	0.22	0.30	0.38
c	0.09	----	0.25
D	9.90	10.20	10.50
e	0.65 BSC		
E	7.40	7.80	8.20
E₁	5.00	5.30	5.60
L	0.55	0.75	0.95
L₁	1.25 REF		
θ	0°	4°	8°
REF:	JEDEC.95, MO-150		

- NOTES:
 A. ALL LINEAR DIMENSIONS ARE IN MILLIMETERS.
 B. THIS DRAWING IS SUBJECT TO CHANGE WITHOUT NOTICE.
 C. BODY DIMENSIONS DO NOT INCLUDE MOLD FLASH OR PROTRUSION, NOT TO EXCEED 0.20MM.
 D. MEETS JEDEC.95 MO-150, VARIATION = AH. REFER TO THIS SPECIFICATION FOR FURTHER DETAILS.

PACKAGE DIMENSIONS - QFN

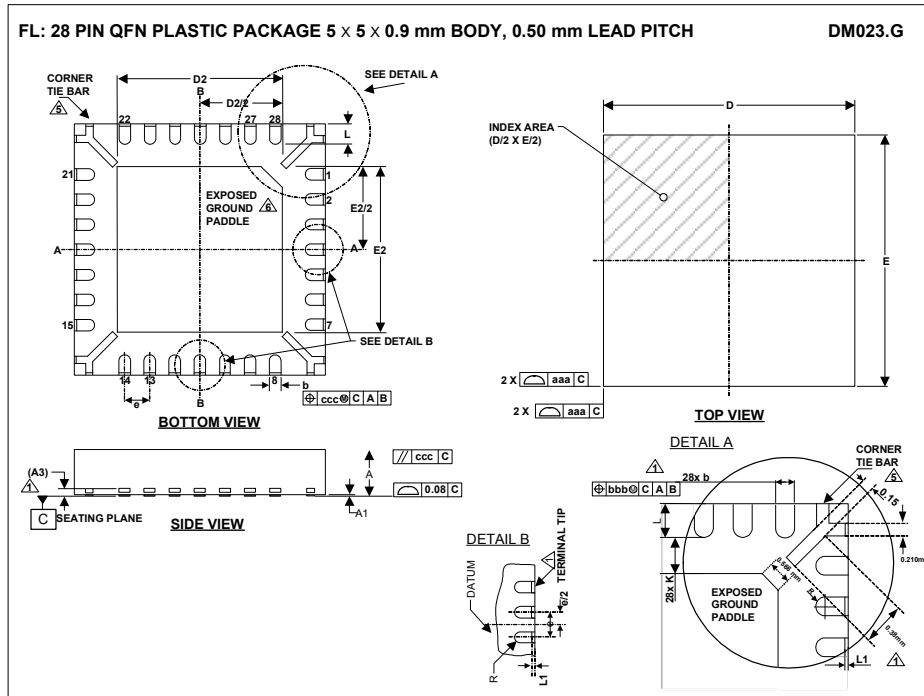

Symbols	Dimensions (mm)			NOTE
	MIN	NOM	MAX	
A	0.85	0.90	1.00	
A1	0	0.02	0.05	
A3		0.2 REF		
b	0.18	0.23	0.30	1
D		5.00 BSC		
D2	3.2	3.3	3.4	2
E		5.00 BSC		
E2	3.2	3.3	3.4	2
e		0.5 BSC		
L	0.35	0.4	0.45	
L1			0.1	1
R	b(min)/2			
K	0.20			
Tolerances of Form and Position				
aaa		0.15		
bbb		0.10		
ccc		0.10		
REF:	JEDEC, MO-220, VARIATION VHHD-1			

- NOTES:
1. DIMENSION b APPLIED TO METALLIZED TERMINAL AND IS MEASURED BETWEEN 0.25 mm AND 0.30 mm FROM TERMINAL TIP. DIMENSION L1 REPRESENTS TERMINAL PULL BACK FROM PACKAGE SIDE WALL. MAXIMUM OF 0.1mm IS ACCEPTABLE. WHERE TERMINAL PULL BACK EXISTS, ONLY UPPER HALF OF LEAD IS VISIBLE ON PACKAGE SIDE WALL DUE TO HALF ETCHING OF LEADFRAME.
 2. FALLS WITHIN JEDEC, MO-220 WITH THE EXCEPTION OF D2, E2:
 3. D2, E2: LARGER PAD SIZE CHOSEN WHICH IS JUST OUTSIDE JEDEC SPECIFICATION
 4. ALL DIMENSIONS ARE IN MILLIMETRES
 5. THIS DRAWING IS SUBJECT TO CHANGE WITHOUT NOTICE.
 6. SHAPE AND SIZE OF CORNER TIE BAR MAY VARY WITH PACKAGE TERMINAL COUNT. CORNER TIE BAR IS CONNECTED TO EXPOSED PAD INTERNALLY
 7. REFER TO APPLICATION NOTE WAN_0118 FOR FURTHER INFORMATION REGARDING PCB FOOTPRINTS AND QFN PACKAGE SOLDERING.

IMPORTANT NOTICE

Wolfson Microelectronics plc ("Wolfson") products and services are sold subject to Wolfson's terms and conditions of sale, delivery and payment supplied at the time of order acknowledgement.

Wolfson warrants performance of its products to the specifications in effect at the date of shipment. Wolfson reserves the right to make changes to its products and specifications or to discontinue any product or service without notice. Customers should therefore obtain the latest version of relevant information from Wolfson to verify that the information is current.

Testing and other quality control techniques are utilised to the extent Wolfson deems necessary to support its warranty. Specific testing of all parameters of each device is not necessarily performed unless required by law or regulation.

In order to minimise risks associated with customer applications, the customer must use adequate design and operating safeguards to minimise inherent or procedural hazards. Wolfson is not liable for applications assistance or customer product design. The customer is solely responsible for its selection and use of Wolfson products. Wolfson is not liable for such selection or use nor for use of any circuitry other than circuitry entirely embodied in a Wolfson product.

Wolfson's products are not intended for use in life support systems, appliances, nuclear systems or systems where malfunction can reasonably be expected to result in personal injury, death or severe property or environmental damage. Any use of products by the customer for such purposes is at the customer's own risk.

Wolfson does not grant any licence (express or implied) under any patent right, copyright, mask work right or other intellectual property right of Wolfson covering or relating to any combination, machine, or process in which its products or services might be or are used. Any provision or publication of any third party's products or services does not constitute Wolfson's approval, licence, warranty or endorsement thereof. Any third party trade marks contained in this document belong to the respective third party owner.

Reproduction of information from Wolfson datasheets is permissible only if reproduction is without alteration and is accompanied by all associated copyright, proprietary and other notices (including this notice) and conditions. Wolfson is not liable for any unauthorised alteration of such information or for any reliance placed thereon.

Any representations made, warranties given, and/or liabilities accepted by any person which differ from those contained in this datasheet or in Wolfson's standard terms and conditions of sale, delivery and payment are made, given and/or accepted at that person's own risk. Wolfson is not liable for any such representations, warranties or liabilities or for any reliance placed thereon by any person.

ADDRESS:

Wolfson Microelectronics plc
Westfield House
26 Westfield Road
Edinburgh
EH11 2QB
United Kingdom

Tel :: +44 (0)131 272 7000
Fax :: +44 (0)131 272 7001
Email :: sales@wolfsonmicro.com