

AD9696/AD9698

FEATURES

- 4.5 ns Propagation Delay
- 200 ps Maximum Propagation Delay Dispersion
- Single +5 V or ± 5 V Supply Operation
- Complementary Matched TTL Outputs

APPLICATIONS

- High Speed Line Receivers
- Peak Detectors
- Window Comparators
- High Speed Triggers
- Ultrafast Pulse Width Discriminators

GENERAL DESCRIPTION

The AD9696 and AD9698 are ultrafast TTL-compatible voltage comparators able to achieve propagation delays previously possible only in high performance ECL devices. The AD9696 is a single comparator providing 4.5 ns propagation delay, 200 ps maximum delay dispersion and 1.7 ns setup time. The AD9698 is a dual comparator with equally high performance; both devices are ideal for critical timing circuits in such applications as ATE, communications receivers and test instruments.

Both devices allow the use of either a single +5 V supply or ± 5 V supplies. The choice of supplies determines the common mode input voltage range available: -2.2 V to +3.7 V for ± 5 V operation, +1.4 V to +3.7 V for single +5 V supply operation.

The differential input stage features high precision, with offset voltages that are less than 2 mV and offset currents less than 1 μ A. A latch enable input is provided to allow operation in either sample-and-hold or track-and-hold applications.

The AD9696 and AD9698 are both available as commercial temperature range devices operating from ambient temperatures of 0°C to +70°C, and as extended temperature range devices for ambient temperatures from -55 °C to +125°C. Both versions are available qualified to MIL-STD-883 class B.

Package options for the AD9696 include a 10-pin TO-100 metal can, an 8-pin ceramic DIP, an 8-pin plastic DIP, and an 8-lead small outline plastic package. The AD9698 is available in a 16-pin ceramic DIP, a 16-lead ceramic gullwing, a 16-pin plastic DIP and a 16-lead small outline plastic package. Military qualified versions of the AD9696 come in the TO-100 can and ceramic DIP; the dual AD9698 comes in ceramic DIP.

FUNCTIONAL BLOCK DIAGRAM

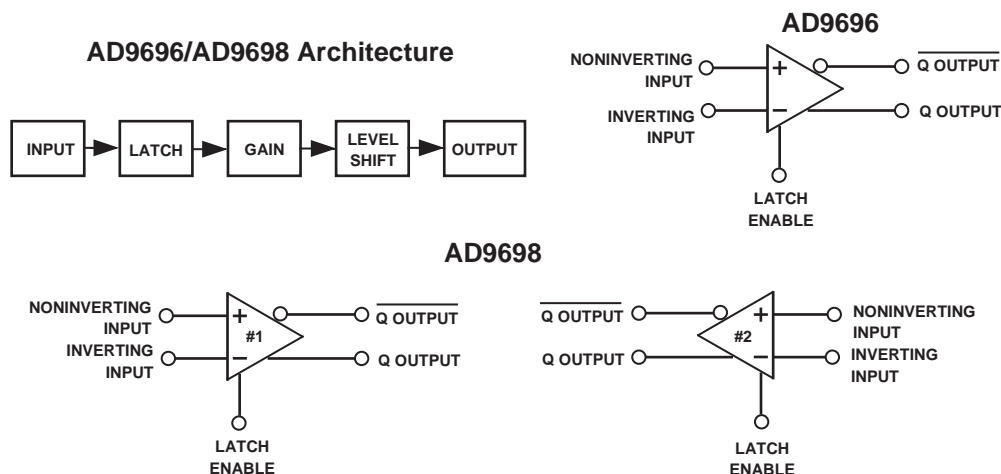

REV. B

Information furnished by Analog Devices is believed to be accurate and reliable. However, no responsibility is assumed by Analog Devices for its use, nor for any infringements of patents or other rights of third parties which may result from its use. No license is granted by implication or otherwise under any patent or patent rights of Analog Devices.

One Technology Way, P.O. Box 9106, Norwood, MA 02062-9106, U.S.A.
 Tel: 617/329-4700 World Wide Web Site: <http://www.analog.com>
 Fax: 617/326-8703 © Analog Devices, Inc., 1997

AD9696/AD9698—SPECIFICATIONS

ABSOLUTE MAXIMUM RATINGS¹

Supply Voltage (+V _S /−V _S)	+7 V/−7 V
Input Voltage Range	±5 V
Differential Input Voltage	5.4 V
Latch Enable Voltage	−0.5 V to +V _S
Output Current (Continuous)	20 mA
Power Dissipation	600 mW

Operating Temperature Range²

AD9696/AD9698KN/KQ/KR	0°C to +70°C
AD9696/AD9698TQ	−55°C to +125°C
Storage Temperature Range	−65°C to +150°C
Junction Temperature	
KQ/TQ Suffixes	+175°C
KN/KR Suffixes	+150°C
Lead Soldering Temperature (10 sec)	+300°C

ELECTRICAL CHARACTERISTICS (Supply Voltages = −5.2 V and +5.0 V; load as specified in Note 4, unless otherwise noted)

Parameter	Temp	Test Level	0°C to +70°C AD9696/AD9698 KN/KQ/KR			−55°C to +125°C AD9696/AD9698 TQ			Units
			Min	Typ	Max	Min	Typ	Max	
INPUT CHARACTERISTICS									
Input Offset Voltage ⁴	+25°C	I		1.0	2.0		1.0	2.0	mV
	Full	VI			3.0			3.0	mV
Input Offset Voltage Drift	Full	V		10			10		μV/°C
Input Bias Current	+25°C	I		16	55		16	55	μA
	Full	VI			110			110	μA
Input Offset Current	+25°C	I		0.4	1.0		0.4	1.0	μA
	Full	VI			1.3			1.3	μA
Input Capacitance	+25°C	V		3			3		pF
Input Voltage Range									
±5.0 V	Full	VI	−2.2		+3.7	−2.2		+3.7	V
+5.0 V	Full	VI	+1.4		+3.7	+1.4		+3.7	V
Common Mode Rejection Ratio									
±5.0 V	Full	VI	80	85		80	85		dB
+5.0 V	Full	VI	57	63		57	63		dB
LATCH ENABLE INPUT									
Logic “1” Voltage Threshold	Full	VI	2.0			2.0			V
Logic “0” Voltage Threshold	Full	VI			0.8			0.8	V
Logic “1” Current	Full	VI			10			10	μA
Logic “0” Current	Full	VI			1			1	μA
DIGITAL OUTPUTS									
Logic “1” Voltage (Source 4 mA)	Full	VI	2.7	3.5		2.7	3.5		V
Logic “0” Voltage (Sink 10 mA)	Full	VI		0.4	0.5		0.4	0.5	V
SWITCHING PERFORMANCE									
Propagation Delay (t _{PD}) ⁵									
Input to Output HIGH	Full	IV		4.5	7.0		4.5	7.0	ns
Input to Output LOW	Full	IV		4.5	7.0		4.5	7.0	ns
Latch Enable to Output HIGH	+25°C	IV		6.5	8.5		6.5	8.5	ns
Latch Enable to Output LOW	+25°C	IV		6.5	8.5		6.5	8.5	ns
Delta Delay Between Outputs	+25°C	IV		0.5	1.5		0.5	1.5	ns
Propagation Delay Dispersion									
20 mV to 100 mV Overdrive	+25°C	V		100			100		ps
100 mV to 1.0 V Overdrive	+25°C	IV		100	200		100	200	ps
Rise Time ¹⁰	+25°C	V		1.85			1.85		ns
Fall Time ¹⁰	+25°C	V		1.35			1.35		ns
Latch Enable									
Pulse Width [t _{PW(E)}]	+25°C	IV	3.5	2.5		3.5	2.5		ns
Setup Time (t _S)	+25°C	IV	3	1.7		3	1.7		ns
Hold Time (t _H)	+25°C	IV	3	1.9		3	1.9		ns

Parameter	Temp	Test Level	0°C to +70°C AD9696/AD9698 KN/KQ/KR			-55°C to +125°C AD9696/AD9698 TQ			Units
			Min	Typ	Max	Min	Typ	Max	
POWER SUPPLY⁶									
Positive Supply Current ⁷									(+5.0 V)
AD9696	Full	VI		26	32		26	32	mA
AD9698	Full	VI		52	64		52	64	mA
Negative Supply Current ⁸									(-5.2 V)
AD9696	Full	VI		2.5	4.0		2.5	4.0	mA
AD9698	Full	VI		5.0	8.0		5.0	8.0	mA
Power Dissipation									
AD9696 +5.0 V	Full	V		130			130		mW
AD9696 ±5.0 V	Full	V		146			146		mW
AD9698 +5.0 V	Full	V		260			260		mW
AD9698 ±5.0 V	Full	V		292			292		mW
Power Supply Rejection Ratio ⁹	+25°C	VI	70			70			dB
	Full	VI	65			65			dB

NOTES

¹Absolute maximum ratings are limiting values, to be applied individually, and beyond which the serviceability of the circuit may be impaired. Functional operability is not necessarily implied. Exposure to absolute maximum rating conditions for an extended period of time may affect device reliability.

²Typical thermal impedances:

AD9696 Metal Can	$\theta_{JA} = 170^{\circ}\text{C/W}$	$\theta_{JC} = 50^{\circ}\text{C/W}$
AD9696 Ceramic DIP	$\theta_{JA} = 110^{\circ}\text{C/W}$	$\theta_{JC} = 20^{\circ}\text{C/W}$
AD9696 Plastic DIP	$\theta_{JA} = 160^{\circ}\text{C/W}$	$\theta_{JC} = 30^{\circ}\text{C/W}$
AD9696 Plastic SOIC	$\theta_{JA} = 180^{\circ}\text{C/W}$	$\theta_{JC} = 30^{\circ}\text{C/W}$
AD9698 Ceramic DIP	$\theta_{JA} = 90^{\circ}\text{C/W}$	$\theta_{JC} = 25^{\circ}\text{C/W}$
AD9698 Plastic DIP	$\theta_{JA} = 100^{\circ}\text{C/W}$	$\theta_{JC} = 20^{\circ}\text{C/W}$
AD9698 Plastic SOIC	$\theta_{JA} = 120^{\circ}\text{C/W}$	$\theta_{JC} = 20^{\circ}\text{C/W}$

³Load circuit has 420 Ω from +V_S to output; 460 Ω from output to ground.

⁴R_S ≤ 100 Ω .

⁵Propagation delays measured with 100 mV pulse; 10 mV overdrive.

⁶Supply voltages should remain stable within ±5% for normal operation.

⁷Specification applies to both +5 V and ±5 V supply operation.

⁸Specification applies to only ±5 V supply operation.

⁹Measured with nominal values ±5% of +V_S and -V_S.

¹⁰Although fall time is faster than rise time, the complementary outputs cross at midpoint of logic swing because of delay on start of falling edge.

Specifications subject to change without notice.

EXPLANATION OF TEST LEVELS

Test Level

- I – 100% production tested.
- II – 100% production tested at +25°C, and sample tested at specified temperatures.
- III – Sample tested only.
- IV – Parameter is guaranteed by design and characterization testing.
- V – Parameter is a typical value only.
- VI – All devices are 100% production tested at +25°C. 100% production tested at temperature extremes for extended temperature devices; sample tested at temperature extremes for commercial/industrial devices.

ORDERING GUIDE

Model	Package	Temperature	Package Option ¹
AD9696KN	Plastic DIP	0°C to +70°C	N-8
AD9696KR	SOIC	0°C to +70°C	R-8
AD9696KQ	Cerdip	0°C to +70°C	Q-8
AD9696TQ	Cerdip	-55°C to +125°C	Q-8
AD9696TZ/883B ²	Gullwing	-55°C to +125°C	Z-8A
AD9698KN	Plastic DIP	0°C to +70°C	N-16
AD9698KR	SOIC	0°C to +70°C	R-16A
AD9698KQ	Cerdip	0°C to +70°C	Q-16
AD9698TQ	Cerdip	-55°C to +125°C	Q-16
AD9698TZ/883B ³	Gullwing	-55°C to +125°C	Z-16

NOTES

¹N = Plastic DIP, Q = Cerdip, R = Small Outline (SOIC), Z = Ceramic Leaded Chip Carrier.

²Refer to AD9696TZ/883B military data sheet.

³Refer to AD9698TZ/883B military data sheet.

PIN CONFIGURATIONS

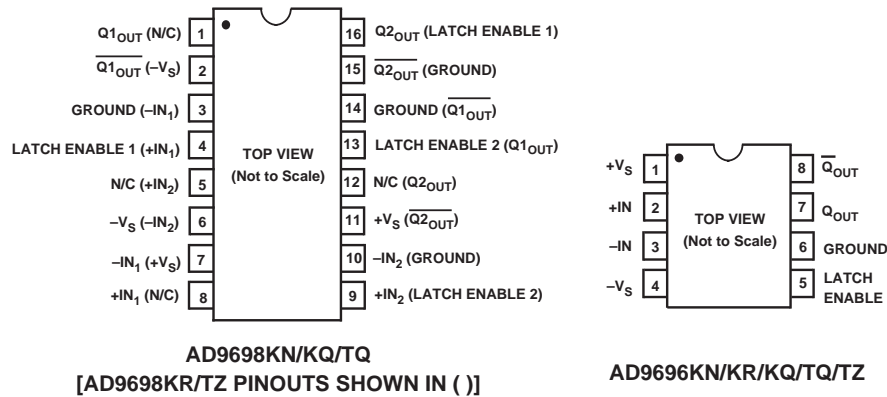

Name	Function
$Q1_{OUT}$	One of two complementary outputs. $Q1_{OUT}$ will be at logic HIGH if voltage at $+IN_1$ is greater than voltage at $-IN_1$ and LATCH ENABLE 1 is at logic LOW.
$\overline{Q1_{OUT}}$	One of two complementary outputs. $\overline{Q1_{OUT}}$ will be at logic HIGH if voltage at $-IN_1$ is greater than voltage at $+IN_1$ and LATCH ENABLE 1 is at logic LOW.
GROUND	Analog and digital ground return. All GROUND pins should be connected together and to a low impedance ground plane near the comparator.
LATCH ENABLE 1	Output at $Q1_{OUT}$ will track differential changes at the inputs when LATCH ENABLE 1 is at logic LOW. When LATCH ENABLE 1 is at logic HIGH, the output at $Q1_{OUT}$ will reflect the input state at the application of the latch command, delayed by the Latch Enable Setup Time (t_S). Since the architecture of the input stage (see block diagram) is faster than the logic of the latch stage, data will typically be latched if applied to the comparator(s) within 1.7 ns after the latch. This is the Setup Time (t_S); for guaranteed performance, t_S must be 3 ns.
N/C	No internal connection to comparator.
$-V_S$	Negative power supply connection; nominally -5.2 V.
$-IN_1$	Inverting input of differential input stage for Comparator #1.
$+IN_1$	Noninverting input of differential input stage for Comparator #1.
$+IN_2$	Noninverting input of differential input stage for Comparator #2.
$-IN_2$	Inverting input of differential input stage for Comparator #2.
$+V_S$	Positive power supply connection; nominally $+5$ V.
LATCH ENABLE 2	Output at $Q2_{OUT}$ will track differential changes at the inputs when LATCH ENABLE 2 is at logic LOW. When LATCH ENABLE 2 is at logic HIGH, the output at $Q2_{OUT}$ will reflect the input state at the application of the latch command, delayed by the Latch Enable Setup Time (t_S). Since the architecture of the input stage (see block diagram) is faster than the logic of the latch stage, data will typically be latched if applied to the comparator(s) within 1.7 ns after the latch. This is the Setup Time (t_S); for guaranteed performance, t_S must be 3 ns.
$\overline{Q2_{OUT}}$	One of two complementary outputs. $\overline{Q2_{OUT}}$ will be at logic HIGH if voltage at $-IN_2$ is greater than voltage at $+IN_2$ and LATCH ENABLE 2 is at logic LOW.
$Q2_{OUT}$	One of two complementary outputs. $Q2_{OUT}$ will be at logic HIGH if voltage at $+IN_2$ is greater than voltage at $-IN_2$ and LATCH ENABLE 2 is at logic LOW.

CAUTION

ESD (electrostatic discharge) sensitive device. Electrostatic charges as high as 4000 V readily accumulate on the human body and test equipment and can discharge without detection. Although the AD9696/AD9698 features proprietary ESD protection circuitry, permanent damage may occur on devices subjected to high energy electrostatic discharges. Therefore, proper ESD precautions are recommended to avoid performance degradation or loss of functionality.



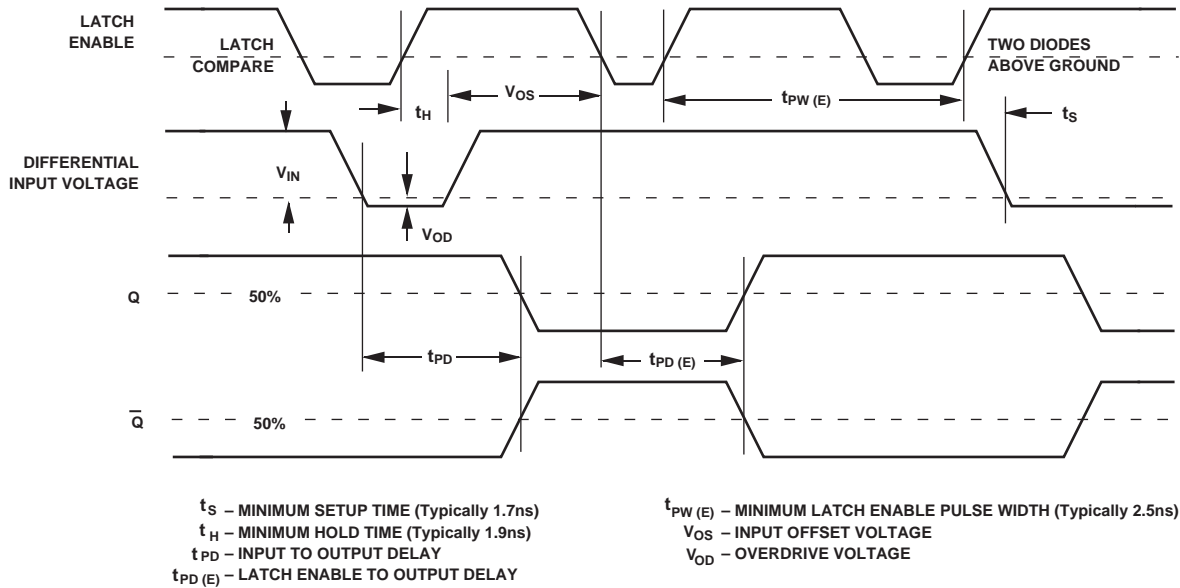

AD9696/AD9698 Timing Diagram

DIE LAYOUT AND MECHANICAL INFORMATION

Die Dimensions AD9696	59×71×15 (±2) mils
AD9698	79×109×15 (±2) mils
Pad Dimensions	4×4 mils
Metalization	Aluminum
Backing	None
Substrate Potential	-V _S
Passivation	Nitride

THEORY OF OPERATION

Refer to the block diagram of the AD9696/AD9698 comparators. The AD9696 and AD9698 TTL voltage comparator architecture consists of five basic stages: input, latch, gain, level shift and output. Each stage is designed to provide optimal performance and make it easy to use the comparators.

The input stage operates with either a single +5-volt supply, or with a +5-volt supply and a -5.2-volt supply. For optimum power efficiency, the remaining stages operate with only a single +5-volt supply. The input stage is an input differential pair without the customary emitter follower buffers. This configuration increases input bias currents but maximizes the input voltage range.

A latch stage allows the most recent output state to be retained as long as the latch input is held high. In this way, the input to the comparator can be changed without any change in the output state. As soon as the latch enable input is switched to LOW, the output changes to the new value dictated by the signal applied to the input stage.

The gain stage assures that even with small values of input voltage, there will be sufficient levels applied to the following stages to cause the output to switch TTL states as required. A level shift stage between the gain stage and the TTL output stage guarantees that appropriate voltage levels are applied from the gain stage to the TTL output stage.

Only the output stage uses TTL logic levels; this minimum use of TTL circuits maximizes speed and minimizes power consumption. The outputs are clamped with Schottky diodes to assure that the rising and falling edges of the output signal are closely matched.

The AD9696 and AD9698 represent the state of the art in high speed TTL voltage comparators. Great care has been taken to optimize the propagation delay dispersion performance. This assures that the output delays will remain constant despite varying levels of input overdrive. This characteristic, along with closely matched rising and falling outputs, provides extremely consistent results at previously unattainable speeds.

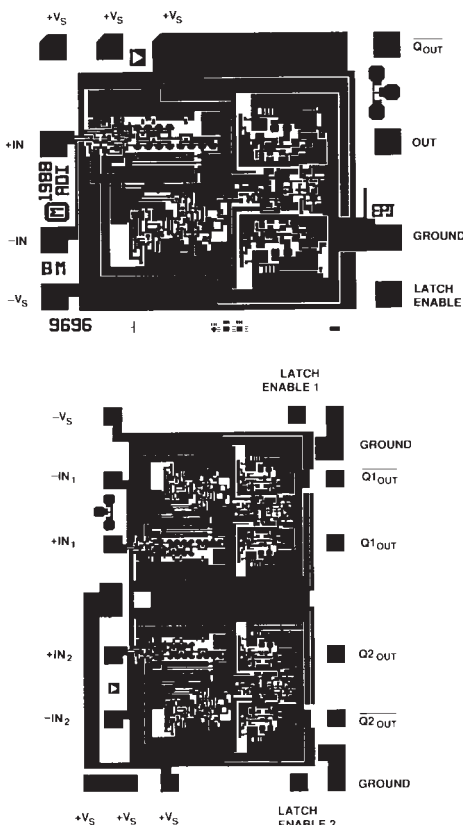

AD9696/AD9698

APPLICATIONS

General

Two characteristics of the AD9696 and AD9698 should be considered for any application. First is the fact that all TTL comparators are prone to oscillate if the inputs are close to equal for any appreciable period of time. One instance of this happening would be slow changes in the unknown signal; the probability of oscillation is reduced when the unknown signal passes through the threshold at a high slew rate. Another instance is if the unknown signal does not overdrive the comparator logic. Unless they are overdriven, TTL comparators have undershoot when switching logic states. The smaller the overdrive, the greater the undershoot; when small enough, the comparator will oscillate, not being able to determine a valid logic state. For the AD9696 and AD9698, 20 mV is the smallest overdrive which will assure crisp switching of logic states without significant undershoot.

The second characteristic to keep in mind when designing threshold circuits for these comparators is twofold: (1) bias currents change when the threshold is exceeded; and (2) ac input impedance decreases when the comparator is in its linear region.

During the time both transistors in the differential pair are conducting, the ac input impedance drops by orders of magnitude. Additionally, the input bias current switches from one input to the other, depending upon whether or not the threshold is exceeded. As a result, the input currents follow approximately the characteristic curves shown below.

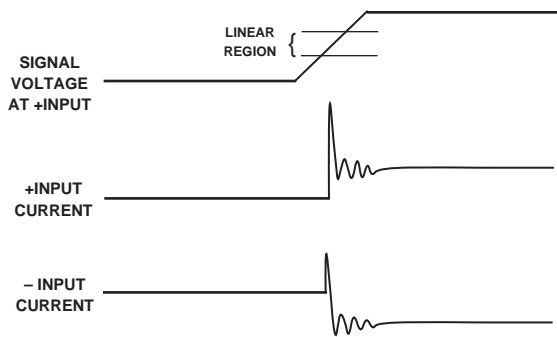

Threshold Input Currents

This characteristic will not cause problems unless a high impedance threshold circuit or drive circuit is employed. A circuit similar to that shown in the window comparator application can eliminate this possible problem.

Window Comparator

Many applications require determining when a signal's voltage falls within, above, or below a particular voltage range. A simple tracking window comparator can provide this data. Figure 1 shows such a window comparator featuring high speed, TTL compatibility, and ease of implementation.

Two comparators are required to establish a "window" with upper and lower threshold voltages. The circuit shown uses the AD9698 dual ultrafast TTL comparator. In addition to the cost and space savings over a design using two single comparators, the dual comparator on a single die produces better matching of both dc and dynamic characteristics.

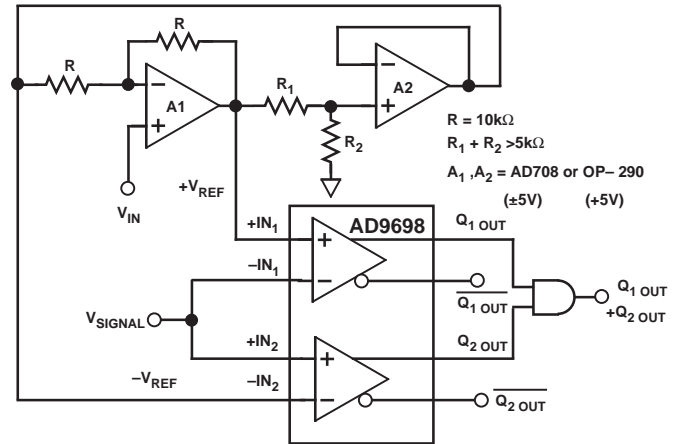

Figure 1. AD9698 Used as Window Detector

When configured as shown, the op amps generate reference levels for the comparators that are equally spaced above and below the applied V_{IN} . The width of the window is established by the ratio of R_1 and R_2 . For a given ratio of R_1 and R_2 , $+V_{REF}$ and $-V_{REF}$ will be fixed percentages above and below V_{IN} . As an example, using 2.2 k Ω for R_1 and 10 k Ω for R_2 creates a $\pm 10\%$ window. When V_{IN} equals +3 V, $+V_{REF}$ will be +3.3 V and $-V_{REF}$ will be +2.7 V. Likewise, for a -2 V input, the thresholds will be -1.8 V and -2.2 V. Windows of differing percentage width can be calculated with the equation:

$$(1-X)/2X = R_2/R_1$$

where:

$$X = \% \text{ window}$$

Additionally, the low impedance of the op amp outputs assures that the threshold voltages will remain constant when the input currents change as the signal passes through the threshold voltage levels.

The output of the AND gate will be high while the signal is inside the window. $\bar{Q}1_{OUT}$ will be high when the signal is above $+V_{REF}$, and $Q2_{OUT}$ will be high when the signal is below $-V_{REF}$.

Crystal Oscillator

Oscillators are used in a wide variety of applications from audio circuits to waveform generators, from ATE triggers and telecommunications transceivers to radar. Figure 2 shows a versatile and inexpensive oscillator. The circuit uses the AD9696, in a positive feedback mode, and is capable of generating accurate and stable oscillations with frequencies ranging from 1 MHz to more than 40 MHz.

To generate oscillations from 1 to 25 MHz, a fundamental mode crystal is used without the dc blocking capacitor and choke. The parallel capacitor on the inverting input is selected for stability (0.1 μF for 1-10 MHz; 220 pF for frequencies above 10 MHz).

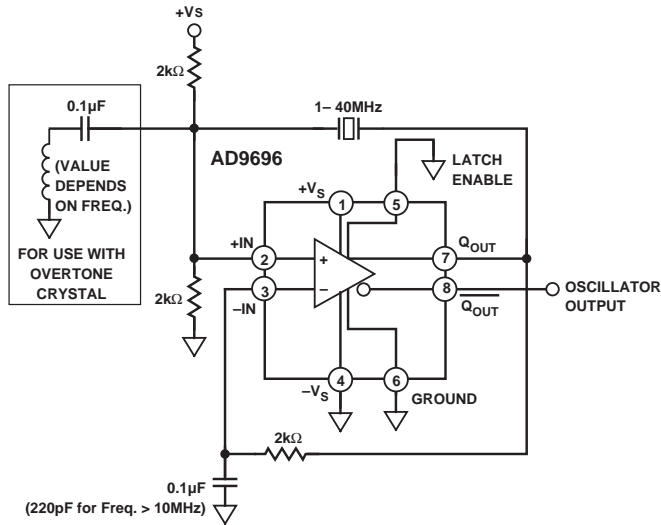

Figure 2. AD9696 Oscillator Circuit (Based on DIP Pinouts)

When generating frequencies using a nonfundamental mode crystal, a choke and dc blocking capacitor are added. As an example, a 36 MHz oscillator can be achieved by using a 12 MHz crystal operating on its third overtone. To suppress oscillation at the 12 MHz fundamental, the value of the choke is chosen to provide a low reactive impedance at the fundamental frequency while maintaining a high reactive impedance at the desired output frequency (for 36 MHz operation, $L = 1.8 \mu\text{H}$). The shunt capacitor at the inverting input has a value of 220 pF for a stable 36 MHz frequency.

LAYOUT CONSIDERATIONS

When working with high speed circuits, proper layout is critical. Analog signal paths should be kept as short as possible and be properly terminated to avoid reflections. In addition, digital signal paths should be kept short, and run lengths should be matched to avoid propagation delay mismatch. All analog signals should be kept as far away from digital signal paths as possible; this reduces the amount of digital switching noise that might be capacitively coupled into the analog section of the circuit.

In high speed circuits, layout of the ground circuit is the most important factor. A single, low impedance ground plane, on the component side of the board, will reduce noise in the circuit ground. It is especially important to maintain continuity of the ground plane under and around the AD9696 or AD9698.

Sockets limit the dynamic performance of the device and should be used only for prototypes or evaluation.

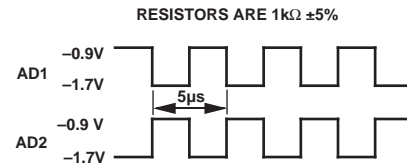
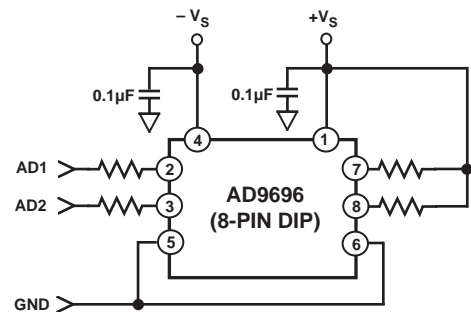

Burn-In Circuit

OUTLINE DIMENSIONS

Dimensions shown in inches and (mm).

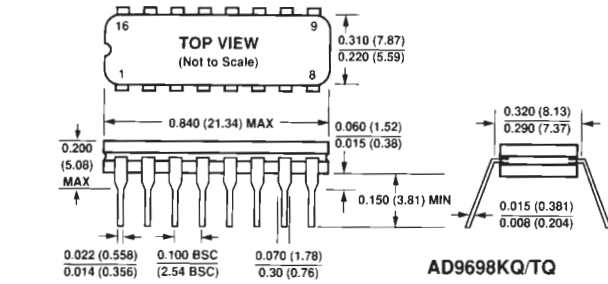

AD9698KQ/TQ

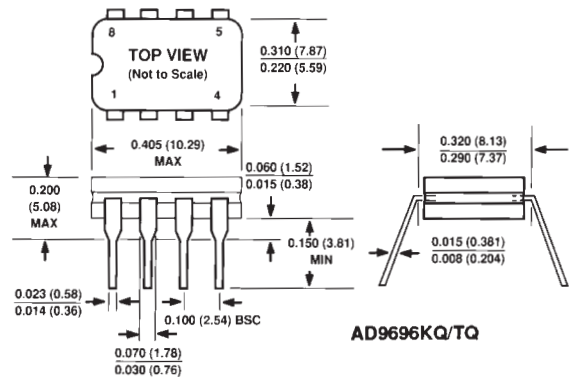

AD9696KQ/TQ

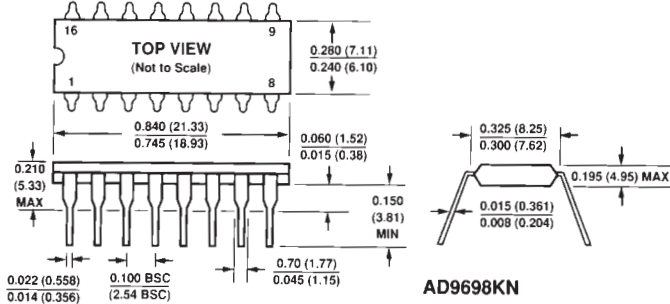

AD9698KN

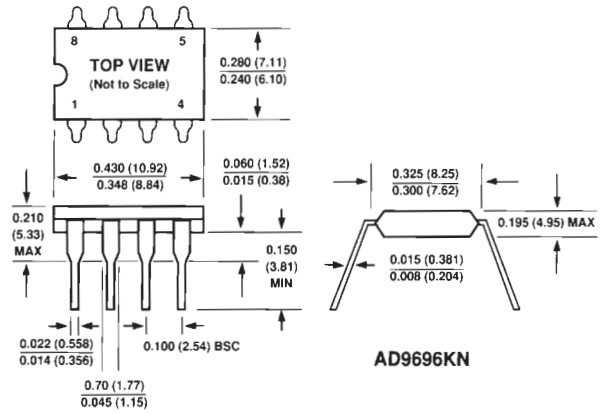

AD9696KN

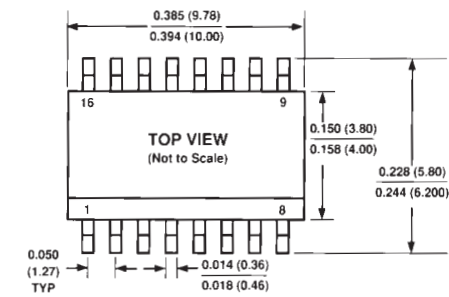

AD9698KR

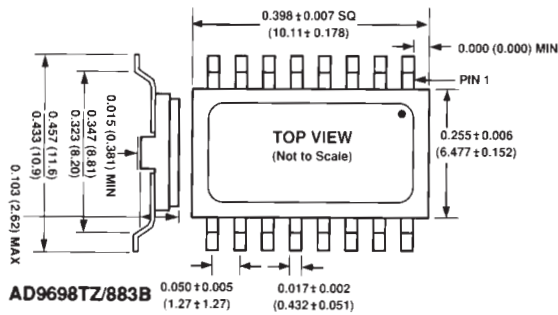
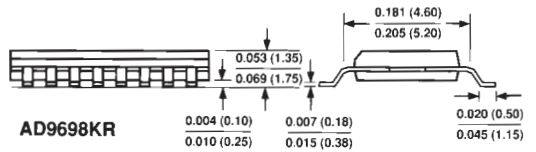

AD9698TZ/883B

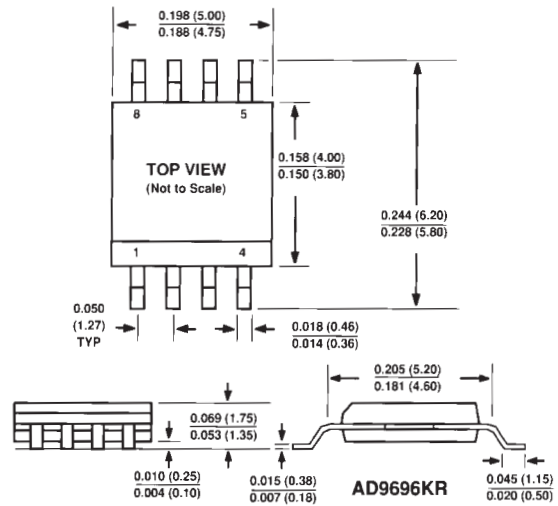

AD9696KR

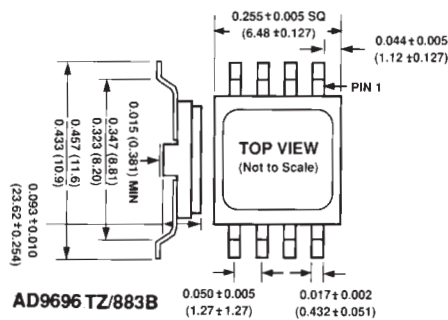

AD9696TZ/883B